

RFID Tag (Passive)

ART868X130903TX13

RoHS/RoHS II compliant



13.0 x 9.0 x 3.0mm

MSL level: Not Applicable

FEATURES:

- RoHS Compliant
- SMD Type
- High Gain

TYPICAL APPLICATIONS:

RFID systems for Logistic & Inventory Management of Retail, Pharmaceutical, Automotive Industries; Industrial automation, Contactless smart cards.

STANDARD SPECIFICATIONS:

Parameters	Min.	Typ.	Max.	Units	Note
Range of Receiving Frequency		865-868		MHz	
Frequency of Lowest Return Loss		893± 3		MHz	(On TEST Plane)
Tag center frequency		868±5		MHz	(On Metal surface)
GAIN	1.0			dBi	(On70x70 GND Plane)
Polarization Model		Linear			(Right Hand Circular Polarization)
Impedance		EPC		Ω	
Working Temperature		-40~+85		°C	
Storage Temperature		-40~+110		°C	
Frequency Temperature Coefficient		0± 10		ppm/°C	

SMITH CHART

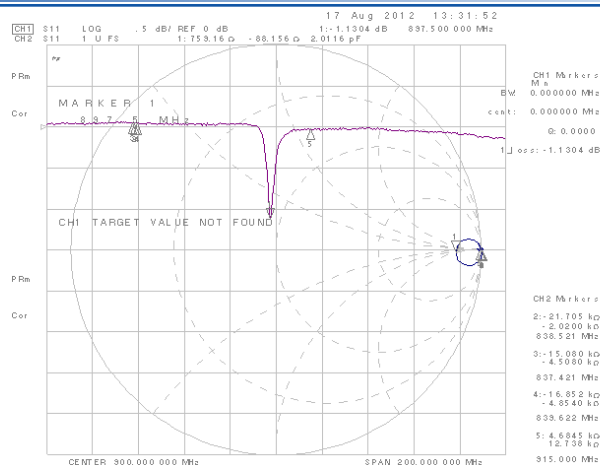

OUTLINE DIMENSION

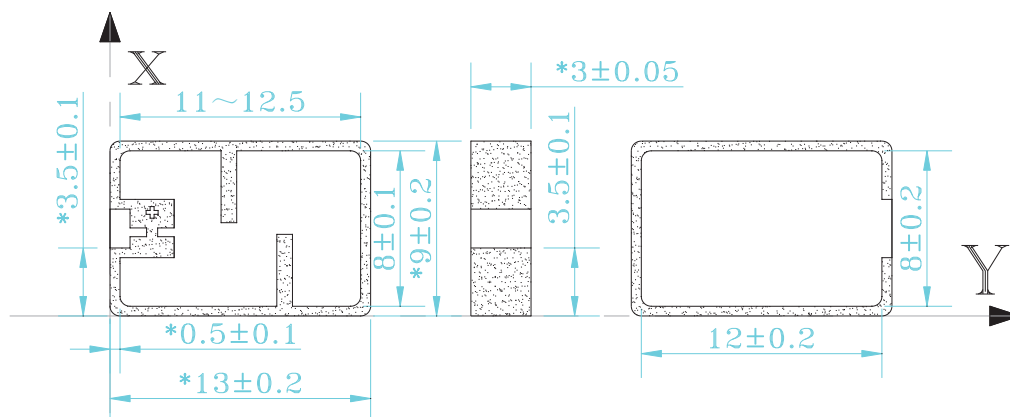

Other Tolerance: ±0.1

Unit: mm

ABRACON IS
 ISO9001:2008
 CERTIFIED



2 Faraday, Suite# B | Irvine | CA 92618 Revised: 11.24.14
 Ph. 949.546.8000 | Fax. 949.546.8001
 Visit www.abracon.com for Terms and Conditions of Sale

RFID Tag (Passive)

ART868X130903TX13

RoHS/RoHS II compliant



13.0 x 9.0 x 3.0mm

PACKAGING

Each tray contains 60pcs of RFID Tag Antenna. There are 6 trays per vacuum bag, 2 vacuum bags per inner box, and 2 inner boxes per carton (outer box) with size of 345*210*275mm.

Package Type	Quantity
Tray	60 pcs/tray
Vacuum Bag	360pcs/vacuum bag
Inner Box	720pcs/inner box
Outer Box	1440pcs/outer box

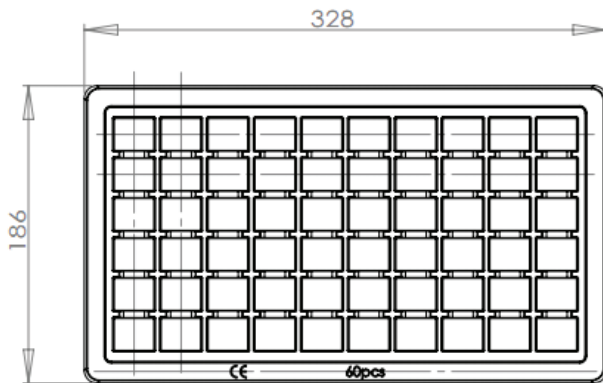

Tray

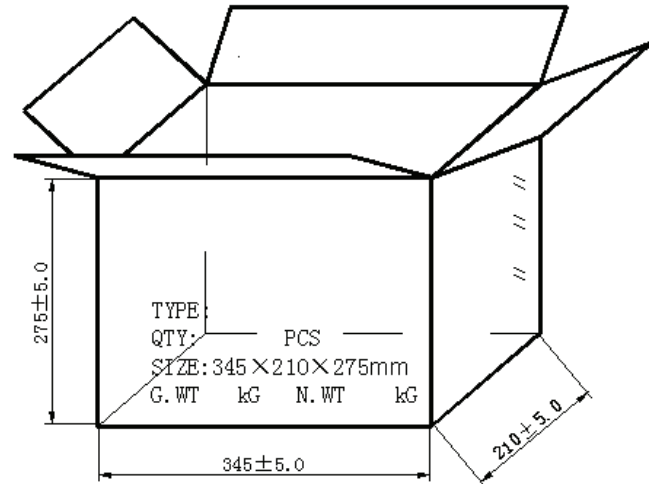

Outer Box

CAUTION:

- (1) Do not apply excess mechanical stress to the component body or terminations. Do not attempt to re-form or bend the components as this will cause damage to the component.
- (2) Do not expose the component to open flame.
- (3) This specification applies to the functionality of the component as a single unit. Please insure the component is thoroughly evaluated in the application circuit.

NOTE:

- 1) The parts are manufactured in accordance with this specification. If other conditions and specifications which are required for this specification, please contact ABRACON for more information.
- 2) ABRACON will supply the parts in accordance with this specification unless we receive a written request to modify prior to an order placement.
- 3) In no case shall ABRACON be liable for any product failure from in appropriate handling or operation of the item beyond the scope of this specification.
- 4) When changing your production process, please notify ABRACON immediately.
- 5) ABRACON Corporation's products are COTS – Commercial-Off-The-Shelf products; suitable for Commercial, Industrial and, where designated, Automotive Applications. ABRACON's products are not specifically designed for Military, Aviation, Aerospace, Life-dependant Medical applications or any application requiring high reliability where component failure could result in loss of life and/or property. For applications requiring high reliability and/or presenting an extreme operating environment, written consent and authorization from ABRACON Corporation is required. Please contact ABRACON Corporation for more information.
- 6) All specifications and Marking will be subject to change without notice.

ATTENTION: Abracon Corporation's products are COTS – Commercial-Off-The-Shelf products; suitable for Commercial, Industrial and, where designated, Automotive Applications. Abracon's products are not specifically designed for Military, Aviation, Aerospace, Life-dependant Medical applications or any application requiring high reliability where component failure could result in loss of life and/or property. For applications requiring high reliability and/or presenting an extreme operating environment, written consent and authorization from Abracon Corporation is required. Please contact Abracon Corporation for more information.

ABRACON IS
ISO9001:2008
CERTIFIED



2 Faraday, Suite# B | Irvine | CA 92618 **Revised: 11.24.14**
Ph. 949.546.8000 | Fax. 949.546.8001
Visit www.abracon.com for Terms and Conditions of Sale

Компания «Life Electronics» занимается поставками электронных компонентов импортного и отечественного производства от производителей и со складов крупных дистрибьюторов Европы, Америки и Азии.

С конца 2013 года компания активно расширяет линейку поставок компонентов по направлению коаксиальный кабель, кварцевые генераторы и конденсаторы (керамические, пленочные, электролитические), за счёт заключения дистрибьюторских договоров

Мы предлагаем:

- Конкурентоспособные цены и скидки постоянным клиентам.
- Специальные условия для постоянных клиентов.
- Подбор аналогов.
- Поставку компонентов в любых объемах, удовлетворяющих вашим потребностям.
- Приемлемые сроки поставки, возможна ускоренная поставка.
- Доставку товара в любую точку России и стран СНГ.
- Комплексную поставку.
- Работу по проектам и поставку образцов.
- Формирование склада под заказчика.
- Сертификаты соответствия на поставляемую продукцию (по желанию клиента).
- Тестирование поставляемой продукции.
- Поставку компонентов, требующих военную и космическую приемку.
- Входной контроль качества.
- Наличие сертификата ISO.

В составе нашей компании организован Конструкторский отдел, призванный помогать разработчикам, и инженерам.

Конструкторский отдел помогает осуществить:

- Регистрацию проекта у производителя компонентов.
- Техническую поддержку проекта.
- Защиту от снятия компонента с производства.
- Оценку стоимости проекта по компонентам.
- Изготовление тестовой платы монтаж и пусконаладочные работы.



Тел: +7 (812) 336 43 04 (многоканальный)

Email: org@lifeelectronics.ru