



The SST39WF800B is a 512K x16 CMOS Multi-Purpose Flash (MPF) manufactured with proprietary, high-performance CMOS SuperFlash technology. The split-gate cell design and thick-oxide tunneling injector attain better reliability and manufacturability compared to alternate approaches. The SST39WF800B writes (Program or Erase) with a 1.65-1.95V power supply. This device conforms to JEDEC standard pin assignments for x16 memories

Features

- **Organized as 512K x16**
- **Single Voltage Read and Write Operations**
 - 1.65-1.95V
- **Superior Reliability**
 - Endurance: 100,000 Cycles (typical)
 - Greater than 100 years Data Retention
- **Low Power Consumption (typical values at 5 MHz)**
 - Active Current: 5 mA (typical)
 - Standby Current: 5 μ A (typical)
- **Sector-Erase Capability**
 - Uniform 2 KWord sectors
- **Block-Erase Capability**
 - Uniform 32 KWord blocks
- **Fast Read Access Time**
 - 70 ns
- **Latched Address and Data**
- **Fast Erase and Word-Program**
 - Sector-Erase Time: 36 ms (typical)
 - Block-Erase Time: 36 ms (typical)
 - Chip-Erase Time: 140 ms (typical)
 - Word-Program Time: 28 μ s (typical)
- **Automatic Write Timing**
 - Internal V_{PP} Generation
- **End-of-Write Detection**
 - Toggle Bit
 - Data# Polling
- **CMOS I/O Compatibility**
- **JEDEC Standard**
 - Flash EEPROM Pinouts and command sets
- **Packages Available**
 - 48-ball TFBGA (6mm x 8mm)
 - 48-ball WFBGA (4mm x 6mm) Micro-Package
 - 48-ball XFLGA (5mm x 6mm) Micro-Package
 - 48-ball XFLGA (4mm x 6mm) Micro-Package
- **All devices are RoHS compliant**



Product Description

The SST39WF800B is a 512K x16 CMOS Multi-Purpose Flash (MPF) manufactured with SST proprietary, high-performance CMOS SuperFlash technology. The split-gate cell design and thick-oxide tunneling injector attain better reliability and manufacturability compared to alternate approaches. The SST39WF800B writes (Program or Erase) with a 1.65-1.95V power supply. This device conforms to JEDEC standard pin assignments for x16 memories.

The SST39WF800B features high-performance Word-Programming which provides a typical Word-Program time of 28 μ sec. It uses Toggle Bit or Data# Polling to detect the completion of the Program or Erase operation. On-chip hardware and software data protection schemes protects against inadvertent writes. Designed, manufactured, and tested for a wide spectrum of applications, the SST39WF800B is offered with a guaranteed typical endurance of 100,000 cycles. Data retention is rated at greater than 100 years.

The SST39WF800B is suited for applications that require convenient and economical updating of program, configuration, or data memory. It significantly improves performance and reliability of all system applications while lowering power consumption. It inherently uses less energy during Erase and Program than alternative flash technologies. When programming a flash device, the total energy consumed is a function of the applied voltage, current, and time of application. For any given voltage range, SuperFlash technology uses less current to program and has a shorter erase time; therefore, the total energy consumed during any Erase or Program operation is less than alternative flash technologies. These devices also improve flexibility while lowering the cost for program, data, and configuration storage applications.

SuperFlash technology provides fixed Erase and Program times independent of the number of Erase/Program cycles that have occurred. Consequently, the system software or hardware does not have to be modified or de-rated as is necessary with alternative flash technologies, whose Erase and Program times increase with accumulated Erase/Program cycles.

To meet surface mount requirements, the SST39WF800B is offered in 48-ball TFBGA, 48-ball WFBGA, and a 48-ball XFLGA packages. See Figures 2 and 3 for pin assignments and Table 1 for pin descriptions.



Block Diagram

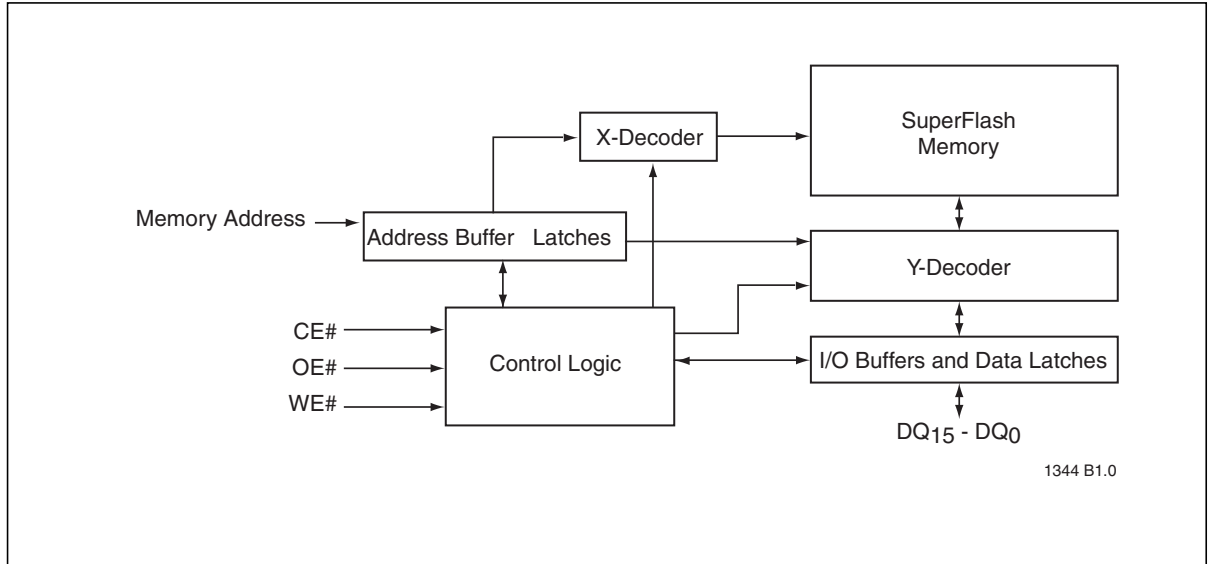

Figure 1: Functional Block Diagram



Pin Assignments

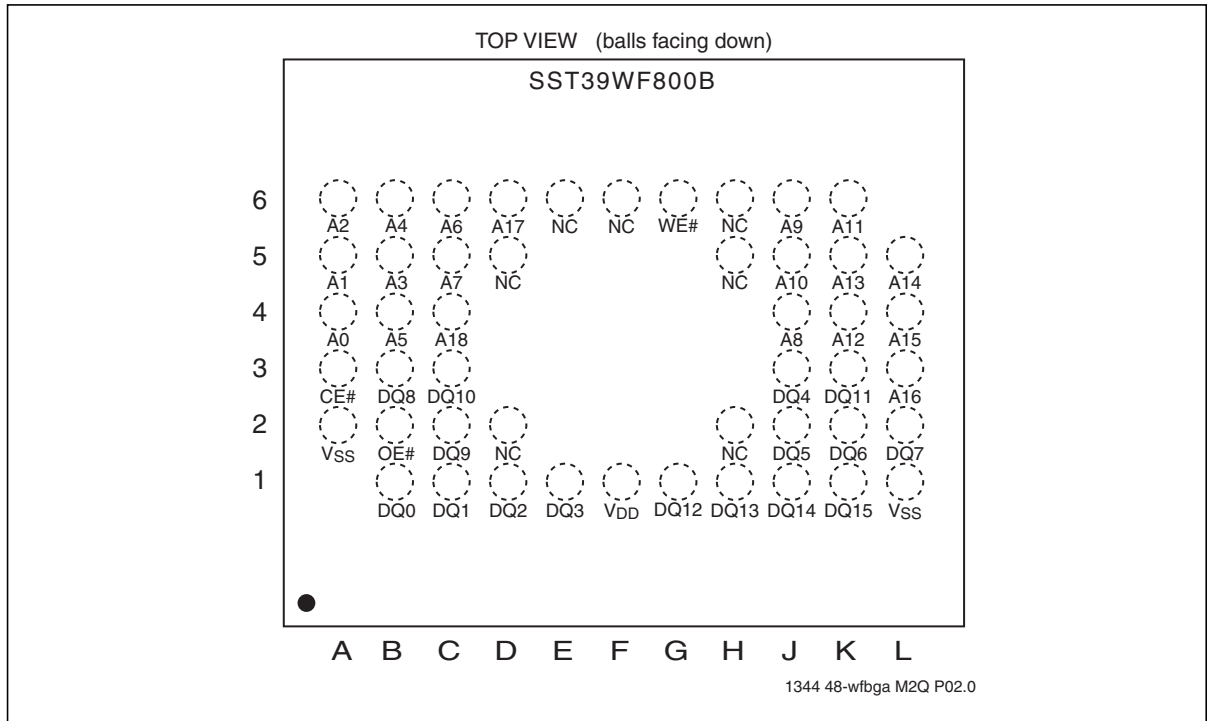

Figure 2: Pin Assignments for 48-Ball WFBGA and 48-Ball XFLGA

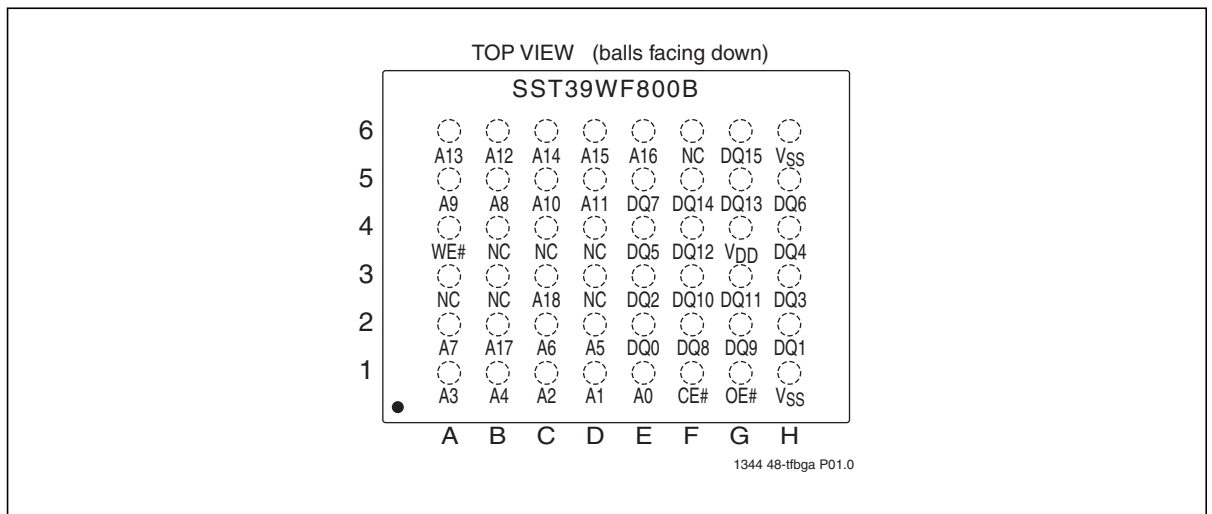

Figure 3: Pin Assignments for 48-ball TFBGA



8 Mbit (x16) Multi-Purpose Flash SST39WF800B

Table 1: Pin Description

Symbol	Pin Name	Functions
$A_{MS}^1-A_0$	Address Inputs	To provide memory addresses. During Sector-Erase $A_{MS}-A_{11}$ address lines will select the sector. During Block-Erase $A_{MS}-A_{15}$ address lines will select the block.
$DQ_{15}-DQ_0$	Data Input/output	To output data during Read cycles and receive input data during Write cycles. Data is internally latched during a Write cycle. The outputs are in tri-state when $OE\#$ or $CE\#$ is high.
$CE\#$	Chip Enable	To activate the device when $CE\#$ is low.
$OE\#$	Output Enable	To gate the data output buffers.
$WE\#$	Write Enable	To control the Write operations.
V_{DD}	Power Supply	To provide power supply voltage: 1.65-1.95V for SST39WF800B
V_{SS}	Ground	
NC	No Connection	Unconnected pins.

T1.0 25031

1. A_{MS} = Most significant address
 $A_{MS} = A_{18}$ for SST39WF800B



Device Operation

Commands, which are used to initiate the memory operation functions of the device, are written to the device using standard microprocessor write sequences. A command is written by asserting WE# low while keeping CE# low. The address bus is latched on the falling edge of WE# or CE#, whichever occurs last. The data bus is latched on the rising edge of WE# or CE#, whichever occurs first.

Read

The Read operation of the SST39WF800B is controlled by CE# and OE#; both have to be low for the system to obtain data from the outputs.

CE# is used for device selection. When CE# is high, the chip is deselected and only standby power is consumed.

OE# is the output control and is used to gate data from the output pins. The data bus is in high impedance state when either CE# or OE# is high. See Figure 5.

Word-Program Operation

The SST39WF800B is programmed on a word-by-word basis. The sector where the word exists must be fully erased before programming.

Programming is accomplished in three steps:

1. Load the three-byte sequence for Software Data Protection.
2. Load word address and word data. During the Word-Program operation, the addresses are latched on the falling edge of either CE# or WE#, whichever occurs last. The data is latched on the rising edge of either CE# or WE#, whichever occurs first.
3. Initiate the internal Program operation after the rising edge of the fourth WE# or CE#, whichever occurs first. Once initiated, the Program operation will be completed within 40 μ s. See Figures 6 and 7 for WE# and CE# controlled Program operation timing diagrams and Figure 17 for flowcharts.

During the Program operation, the only valid reads are Data# Polling and Toggle Bit. During the internal Program operation, the host is free to perform additional tasks. Any commands issued during the internal Program operation are ignored.



Sector-/Block-Erase Operation

The SST39WF800B offers both Sector-Erase and Block-Erase modes which allow the system to erase the device on a sector-by-sector, or block-by-block, basis.

The sector architecture is based on uniform sector size of 2 KWord. Initiate the Sector-Erase operation by executing a six-byte command sequence with Sector-Erase command (30H) and sector address (SA) in the last bus cycle.

The Block-Erase mode is based on uniform block size of 32 KWord. Initiate the Block-Erase operation by executing a six-byte command sequence with Block-Erase command (50H) and block address (BA) in the last bus cycle.

The sector or block address is latched on the falling edge of the sixth WE# pulse, while the command (30H or 50H) is latched on the rising edge of the sixth WE# pulse. The internal Erase operation begins after the sixth WE# pulse.

The End-of-Erase operation can be determined using either Data# Polling or Toggle Bit methods. See Figures 10 and 11 for timing waveforms. Any commands issued during the Sector- or Block-Erase operation are ignored.

Chip-Erase Operation

The SST39WF800B provides a Chip-Erase operation, which allows the user to erase the entire memory array to the '1' state. This is useful when the entire device must be quickly erased.

Initiate the Chip-Erase operation by executing a six-byte command sequence with Chip-Erase command (10H) at address 5555H in the last byte sequence.

The Erase operation begins with the rising edge of the sixth WE# or CE#, whichever occurs first. During the Erase operation, the only valid read is Toggle Bit or Data# Polling. See Table 4 for the command sequence, Figure 9 for the timing diagram, and Figure 20 for the flowchart. Any commands issued during the Chip-Erase operation are ignored.

Write Operation Status Detection

To optimize the system write cycle time, the SST39WF800B provides two software means to detect the completion of a Program or Erase write cycle. The software detection includes two status bits—Data# Polling (DQ₇) and Toggle Bit (DQ₆). The End-of-Write detection mode is enabled after the rising edge of WE#, which initiates the internal Program or Erase operation.

The completion of the nonvolatile Write is asynchronous with the system; therefore, either a Data# Polling or Toggle Bit read may occur simultaneously with the completion of the Write cycle. If this occurs, the system may get an erroneous result, i.e., valid data may appear to conflict with either DQ₇ or DQ₆. To prevent spurious rejection in the event of an erroneous result, the software routine must include a loop to read the accessed location an additional two (2) times. If both Reads are valid, then the device has completed the Write cycle, otherwise the rejection is valid.



Data# Polling (DQ₇)

When the SST39WF800B is in the internal Program operation, any attempt to read DQ₇ will produce the complement of the true data. Once the Program operation is complete, DQ₇ will produce true data.

Although DQ₇ may have valid data immediately following the completion of an internal Write operation, the remaining data outputs may still be invalid. Valid data on the entire data bus will appear in subsequent successive Read cycles after an interval of 1 μ s. During an internal Erase operation, any attempt to read DQ₇ will produce a '0'. Once the internal Erase operation is complete, DQ₇ will produce a '1'.

The Data# Polling is valid after the rising edge of fourth WE# (or CE#) pulse for Program operation. For Sector-, Block-, or Chip-Erase, the Data# Polling is valid after the rising edge of sixth WE# (or CE#) pulse. See Figure 8 for Data# Polling timing diagram and Figure 18 for a flowchart.

Toggle Bit (DQ₆)

During the internal Program or Erase operation, any consecutive attempts to read DQ₆ will produce alternating '1's and '0's, i.e., toggling between '1' and '0'.

When the Program or Erase operation is complete, the DQ₆ bit will stop toggling and the device is ready for the next operation.

The Toggle Bit is valid after the rising edge of fourth WE# (or CE#) pulse for Program operation. For Sector-, Block- or Chip-Erase, the Toggle Bit is valid after the rising edge of sixth WE# (or CE#) pulse. See Figure 0-1 for Toggle Bit timing diagram and Figure 18 for a flowchart.

Data Protection

The SST39WF800B provides both hardware and software features to protect nonvolatile data from inadvertent writes.

Hardware Data Protection

Noise/Glitch Protection: A WE# or CE# pulse of less than 5 ns will not initiate a write cycle.

V_{DD} Power Up/Down Detection: The Write operation is inhibited when V_{DD} is less than 1.0V.

Write Inhibit Mode: Forcing OE# low, CE# high, or WE# high will inhibit the Write operation. This prevents inadvertent writes during power-up or power-down.

Software Data Protection (SDP)

The SST39WF800B provides the JEDEC approved Software Data Protection scheme for all data alteration operations, i.e., Program and Erase. Any Program operation requires the inclusion of the three-byte sequence. The three-byte load sequence is used to initiate the Program operation, providing optimal protection from inadvertent Write operations, e.g., during the system power-up or power-down. Any Erase operation requires the inclusion of six-byte sequence. This group of devices are shipped with the Software Data Protection permanently enabled. See Table 4 for the specific software command codes. During SDP command sequence, invalid commands will abort the device to Read mode within T_{RC}. The contents of DQ₁₅-DQ₈ can be V_{IL} or V_{IH}, but no other value, during any SDP command sequence.



Common Flash Memory Interface (CFI)

The SST39WF800A contains the CFI information that describes the characteristics of the device, and supports both the original SST CFI Query mode implementation for compatibility with existing SST devices, as well as the general CFI Query mode.

To enter the SST CFI Query mode, the system must write the three-byte sequence, same as the Product ID Entry command, with 98H (CFI Query command) to address 5555H in the last byte sequence.

To enter the general CFI Query mode, the system must write a one-byte sequence using the Entry command with 98H to address 55H.

Once the device enters the CFI Query mode, the system can read CFI data at the addresses given in Tables 5 through 7. The system must write the CFI Exit command to return to Read mode from the CFI Query mode.

Product Identification

The Product Identification mode identifies the device as the SST39WF800B and manufacturer as SST. This mode is accessed by software operations. Use Software Product Identification operation to identify the part (i.e., using the device ID) when using multiple manufacturers in the same socket. For details, see Table 4 for software operation, Figure 12 for the Software ID Entry and Read timing diagram, and Figure 19 for the Software ID Entry command sequence flowchart.

Table 2: Product Identification Table

	Address	Data
Manufacturer's ID	0000H	00BFH
Device ID SST39WF800B	0001H	273EH

T2.0 25031

Product Identification Mode Exit/CFI Mode Exit

To return to the standard Read mode, exit the Software Product Identification mode. Issue the Software ID Exit command sequence which returns the device to the Read mode.

The Software ID Exit command may also be used to reset the device to the Read mode after any inadvertent transient condition that causes the device to behave abnormally, e.g., not read correctly.

The Software ID Exit/CFI Exit command is ignored during an internal Program or Erase operation. See Table 4 for software command codes, Figure 14 for timing waveform, and Figure 19 for a flowchart.



Operations

Table 3: Operation Modes Selection

Mode	CE#	OE#	WE#	DQ	Address
Read	V _{IL}	V _{IL}	V _{IH}	D _{OUT}	A _{IN}
Program	V _{IL}	V _{IH}	V _{IL}	D _{IN}	A _{IN}
Erase	V _{IL}	V _{IH}	V _{IL}	X ¹	Sector or Block address, XXH for Chip-Erase
Standby	V _{IH}	X	X	High Z	X
Write Inhibit	X	V _{IL}	X	High Z/ D _{OUT}	X
	X	X	V _{IH}	High Z/ D _{OUT}	X
Product Identification					
Software Mode	V _{IL}	V _{IL}	V _{IH}		See Table 4

T3.0 25031

1. X can be V_{IL} or V_{IH}, but no other value.

Table 4: Software Command Sequence

Command Sequence	1st Bus Write Cycle		2nd Bus Write Cycle		3rd Bus Write Cycle		4th Bus Write Cycle		5th Bus Write Cycle		6th Bus Write Cycle	
	Addr ¹	Data ²	Addr ¹	Data ²	Addr ¹	Data ²	Addr ¹	Data ²	Addr ¹	Data ²	Addr ¹	Data ²
Word-Program	5555H	AAH	2AAAH	55H	5555H	A0H	WA ³	Data				
Sector-Erase	5555H	AAH	2AAAH	55H	5555H	80H	5555H	AAH	2AAAH	55H	SA _X ⁴	30H
Block-Erase	5555H	AAH	2AAAH	55H	5555H	80H	5555H	AAH	2AAAH	55H	BA _X ⁴	50H
Chip-Erase	5555H	AAH	2AAAH	55H	5555H	80H	5555H	AAH	2AAAH	55H	5555H	10H
Software ID Entry ^{5,6}	5555H	AAH	2AAAH	55H	5555H	90H						
SST CFI Query Entry ⁵	5555H	AAH	2AAAH	55H	5555H	98H						
General CFI Query Mode	55H	98H										
Software ID Exit ⁷ / CFI Exit	XXH	FOH										
Software ID Exit ⁷ / CFI Exit	5555H	AAH	2AAAH	55H	5555H	FOH						

T4.0 25031

1. Address format A₁₄-A₀ (Hex), Addresses A_{MS}-A₁₅ can be V_{IL} or V_{IH}, but no other value, for the Command sequence.
A_{MS} = Most significant address
A_{MS} = A₁₈ for SST39WF800B
2. DQ₁₅-DQ₈ can be V_{IL} or V_{IH}, but no other value, for the Command sequence
3. WA = Program word address
4. SA_X for Sector-Erase; uses A_{MS}-A₁₁ address lines
BA_X for Block-Erase; uses A_{MS}-A₁₅ address lines
5. The device does not remain in Software Product ID mode if powered down.
6. With A_{MS}-A₁ = 0; SST Manufacturer's ID = 00BFH, is read with A₀ = 0,
SST39WF800B Device ID = 273EH, is read with A₀ = 1.
7. Both Software ID Exit operations are equivalent

**Table 5:** CFI Query Identification String¹ for SST39WF800B

Address	Data	Data
10H	0051H	Query Unique ASCII string "QRY"
11H	0052H	
12H	0059H	
13H	0001H	Primary OEM command set
14H	0007H	
15H	0000H	Address for Primary Extended Table
16H	0000H	
17H	0000H	Alternate OEM command set (00H = none exists)
18H	0000H	
19H	0000H	Address for Alternate OEM extended Table (00H = none exists)
1AH	0000H	

T5.0 25031

1. Refer to CFI publication 100 for more details.

Table 6: System Interface Information for SST39WF800B

Address	Data	Data
1BH	0016H	V _{DD} Min (Program/Erase) DQ ₇ -DQ ₄ : Volts, DQ ₃ -DQ ₀ : 100 millivolts
1CH	0020H	V _{DD} Max (Program/Erase) DQ ₇ -DQ ₄ : Volts, DQ ₃ -DQ ₀ : 100 millivolts
1DH	0000H	V _{PP} min (00H = no V _{PP} pin)
1EH	0000H	V _{PP} max (00H = no V _{PP} pin)
1FH	0005H	Typical time out for Word-Program 2 ^N μs (2 ⁵ = 32 μs)
20H	0000H	Typical time out for min size buffer program 2 ^N μs (00H = not supported)
21H	0005H	Typical time out for individual Sector/Block-Erase 2 ^N ms (2 ⁵ = 32 ms)
22H	0007H	Typical time out for Chip-Erase 2 ^N ms (2 ⁷ = 128 ms)
23H	0001H	Maximum time out for Word-Program 2 ^N times typical (2 ¹ x 2 ⁵ = 64 μs)
24H	0000H	Maximum time out for buffer program 2 ^N times typical
25H	0001H	Maximum time out for individual Sector/Block-Erase 2 ^N times typical (2 ¹ x 2 ⁵ = 64 ms)
26H	0001H	Maximum time out for Chip-Erase 2 ^N times typical (2 ¹ x 2 ⁷ = 256 ms)

T6.0 25031

**Table 7:** Device Geometry Information for SST39WF800B

Address	Data	Data
27H	0014H	Device size = 2^N Byte (14H = 20; 2^{20} = 1 MByte)
28H	0001H	Flash Device Interface description; 0001H = x16-only asynchronous interface
29H	0000H	
2AH	0000H	Maximum number of byte in multi-byte write = 2^N (00H = not supported)
2BH	0000H	
2CH	0002H	Number of Erase Sector/Block sizes supported by device
2DH	00FFH	Sector Information (y + 1 = Number of sectors; z x 256B = sector size)
2EH	0000H	y = 255 + 1 = 256 sectors (00FFH = 255)
2FH	0010H	z = 16 x 256 Bytes = 4 KByte/sector (0010H = 16)
30H	0000H	
31H	000FH	Block Information (y + 1 = Number of blocks; z x 256B = block size)
32H	0000H	y = 15 + 1 = 16 blocks (000FH = 15)
33H	0000H	z = 256 x 256 Bytes = 64 KByte/block (0100H = 256)
34H	0001H	

T7.0 25031



Electrical Specifications

Absolute Maximum Stress Ratings (Applied conditions greater than those listed under “Absolute Maximum Stress Ratings” may cause permanent damage to the device. This is a stress rating only and functional operation of the device at these conditions or conditions greater than those defined in the operational sections of this data sheet is not implied. Exposure to absolute maximum stress rating conditions may affect device reliability.)

Temperature Under Bias	-55°C to +125°C
Storage Temperature	-65°C to +150°C
D. C. Voltage on Any Pin to Ground Potential	-0.5V to $V_{DD}+0.5V$
Transient Voltage (<20 ns) on Any Pin to Ground Potential	-2.0V to $V_{DD}+2.0V$
Voltage on A ₉ Pin to Ground Potential	-0.5V to 11V
Package Power Dissipation Capability ($T_A = 25^\circ\text{C}$)	1.0W
Surface Mount Solder Reflow Temperature ¹	260°C for 10 seconds
Output Short Circuit Current ²	50 mA

1. Excluding certain with-Pb 32-PLCC units, all packages are 260°C capable in both non-Pb and with-Pb solder versions. Certain with-Pb 32-PLCC package types are capable of 240°C for 10 seconds; please consult the factory for the latest information.
2. Outputs shorted for no more than one second. No more than one output shorted at a time.

Table 8: Operating Range

Range	Ambient Temp	V_{DD}
Commercial	0°C to +70°C	1.65-1.95V
Industrial	-40°C to +85°C	1.65-1.95V

T8.1 25031

Table 9: AC Conditions of Test¹

Input Rise/Fall Time	Output Load
5ns	$C_L = 30 \text{ pF}$

T9.1 25031

1. See Figures 15 and 16



Power-Up Specifications

All functionalities and DC specifications are specified for a V_{DD} ramp rate **faster** than 1V per 100 ms (0V to 1.8V in less than 180 ms). In addition, a V_{DD} ramp rate **slower** than 1V per 20 μ s is recommended. See Table 10 and Figure 4 for more information.

Table 10:Recommended System Power-up Timings

Symbol	Parameter	Minimum	Units
$T_{PU-READ}^1$	V_{DD} Min to Read Operation	100	μ s
$T_{PU-WRITE}^1$	V_{DD} Min to Write Operation	100	μ s

T10.0 25031

1. This parameter is measured only for initial qualification and after a design or process change that could affect this parameter.

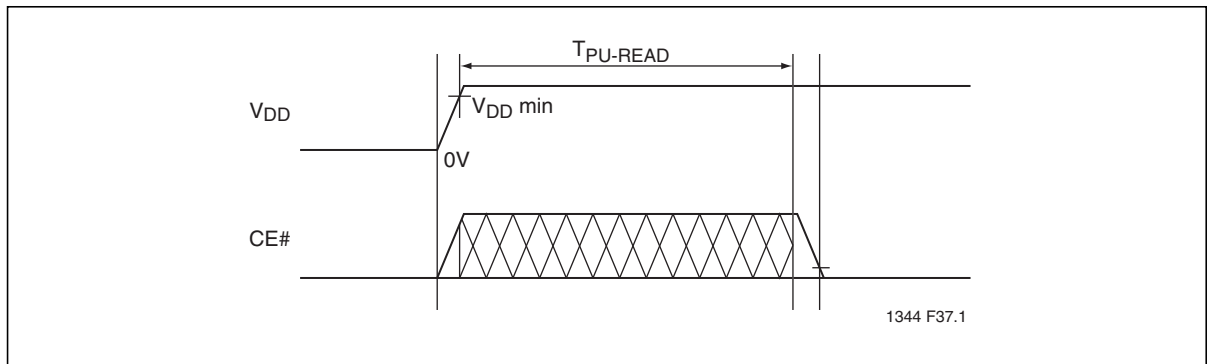

Figure 4:Power-Up Reset Diagram



DC Characteristics

Table 11: DC Operating Characteristics, $V_{DD} = 1.65\text{-}1.95\text{V}^1$

Symbol	Parameter	Limits			Test Conditions
		Min	Max	Units	
I _{DD}	Power Supply Current				Address input= V_{ILT}/V_{IHT} , at f=5 MHz, $V_{DD}=V_{DD} \text{ Max}$
	Read		15	mA	CE#= V_{IL} , OE#= $WE\#=V_{IH}$, all I/Os open
	Program and Erase		20	mA	CE#= $WE\#=V_{IL}$, OE#= V_{IH}
I _{SB}	Standby V_{DD} Current ²		40	μA	CE#= V_{DD} , $V_{DD}=V_{DD} \text{ Max}$
I _{LI}	Input Leakage Current		1	μA	$V_{IN}=\text{GND to } V_{DD}$, $V_{DD}=V_{DD} \text{ Max}$
I _{LO}	Output Leakage Current		1	μA	$V_{OUT}=\text{GND to } V_{DD}$, $V_{DD}=V_{DD} \text{ Max}$
V _{IL}	Input Low Voltage		0.2V _{DD}		$V_{DD}=V_{DD} \text{ Min}$
V _{IH}	Input High Voltage	0.8V _{DD}		V	$V_{DD}=V_{DD} \text{ Max}$
V _{OL}	Output Low Voltage		0.1	V	I _{OL} =100 μA , $V_{DD}=V_{DD} \text{ Min}$
V _{OH}	Output High Voltage	V _{DD} -0.1		V	I _{OH} =-100 μA , $V_{DD}=V_{DD} \text{ Min}$

T11.0 25031

1. Typical conditions for the Active Current shown on the front page of the data sheet are average values at 25°C (room temperature), and $V_{DD} = 1.8\text{V}$. Not 100% tested.
2. 40 μA is the maximum I_{SB} for all SST39WF800B commercial grade devices. 40 μA is the maximum I_{SB} for all 39WF800A industrial grade devices. For all SST39WF800B commercial and industrial devices, I_{SB} typical is under 5 μA .

Table 12: Capacitance ($T_A = 25^\circ\text{C}$, f=1 MHz, other pins open)

Parameter	Description	Test Condition	Maximum
C _{I/O} ¹	I/O Pin Capacitance	$V_{I/O} = 0\text{V}$	12 pF
C _{IN} ¹	Input Capacitance	$V_{IN} = 0\text{V}$	6 pF

T12.0 25031

1. This parameter is measured only for initial qualification and after a design or process change that could affect this parameter.

Table 13: Reliability Characteristics

Symbol	Parameter	Minimum Specification	Units	Test Method
N _{END} ^{1,2}	Endurance	10,000	Cycles	JEDEC Standard A117
T _{DR} ¹	Data Retention	100	Years	JEDEC Standard A103
I _{LTH} ¹	Latch Up	100 + I _{DD}	mA	JEDEC Standard 78

T13.0 25031

1. This parameter is measured only for initial qualification and after a design or process change that could affect this parameter.
2. N_{END} endurance rating is qualified as a 10,000 cycle minimum for the whole device. A sector- or block-level rating would result in a higher minimum specification.



AC Characteristics

Table 14:Read Cycle Timing Parameters

Symbol	Parameter	70 ns		Units
		Min	Max	
T _{RC}	Read Cycle Time	70		ns
T _{CE}	Chip Enable Access Time		70	ns
T _{AA}	Address Access Time		70	ns
T _{OE}	Output Enable Access Time		35	ns
T _{CLZ} ¹	CE# Low to Active Output	0		ns
T _{OLZ} ¹	OE# Low to Active Output	0		ns
T _{CHZ} ¹	CE# High to High-Z Output		40	ns
T _{OHZ} ¹	OE# High to High-Z Output		40	ns
T _{OH} ¹	Output Hold from Address Change	0		ns

T14.0 25031

1. This parameter is measured only for initial qualification and after a design or process change that could affect this parameter.

Table 15:Program/Erase Cycle Timing Parameters

Symbol	Parameter	Min	Max	Units
T _{BP}	Word-Program Time		40	μs
T _{AS}	Address Setup Time	0		ns
T _{AH}	Address Hold Time	50		ns
T _{CS}	WE# and CE# Setup Time	0		ns
T _{CH}	WE# and CE# Hold Time	0		ns
T _{OES}	OE# High Setup Time	0		ns
T _{OEH}	OE# High Hold Time	10		ns
T _{CP}	CE# Pulse Width	50		ns
T _{WP}	WE# Pulse Width	50		ns
T _{WPH} ¹	WE# Pulse Width High	30		ns
T _{CPH} ¹	CE# Pulse Width High	30		ns
T _{DS}	Data Setup Time	50		ns
T _{DH} ¹	Data Hold Time	0		ns
T _{IDA} ¹	Software ID Access and Exit Time		150	ns
T _{SE}	Sector-Erase		50	ms
T _{BE}	Block-Erase		50	ms
T _{SCE}	Chip-Erase		200	ms

T15.0 25031

1. This parameter is measured only for initial qualification and after a design or process change that could affect this parameter.

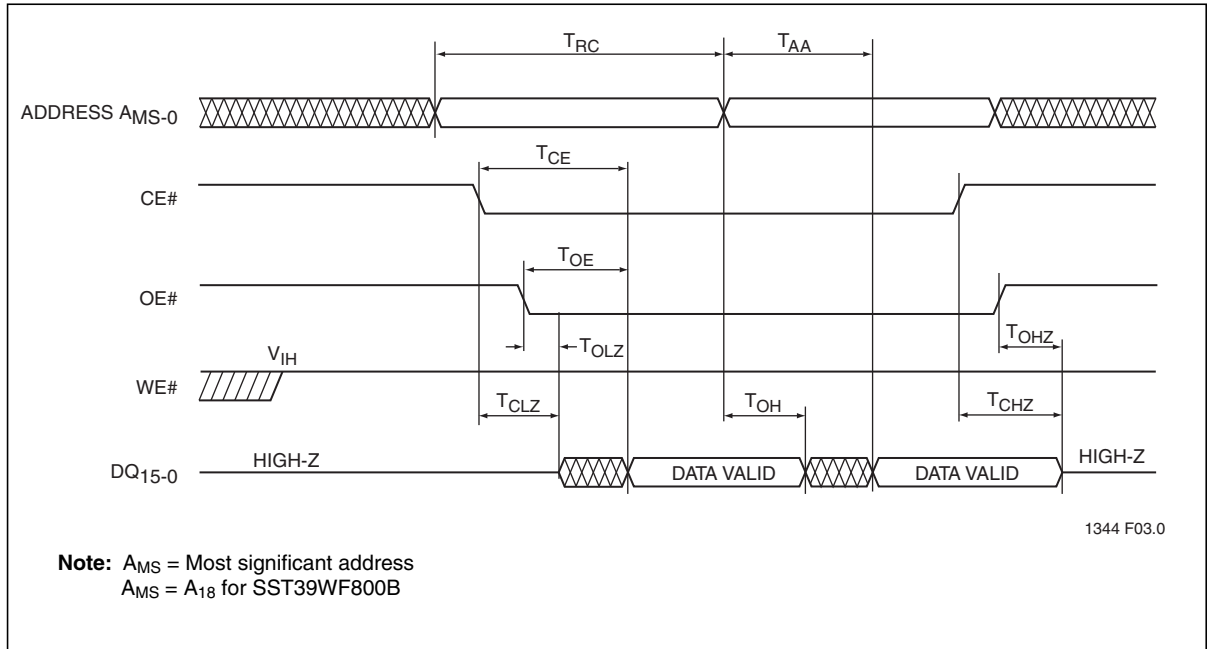

Figure 5: Read Cycle Timing Diagram

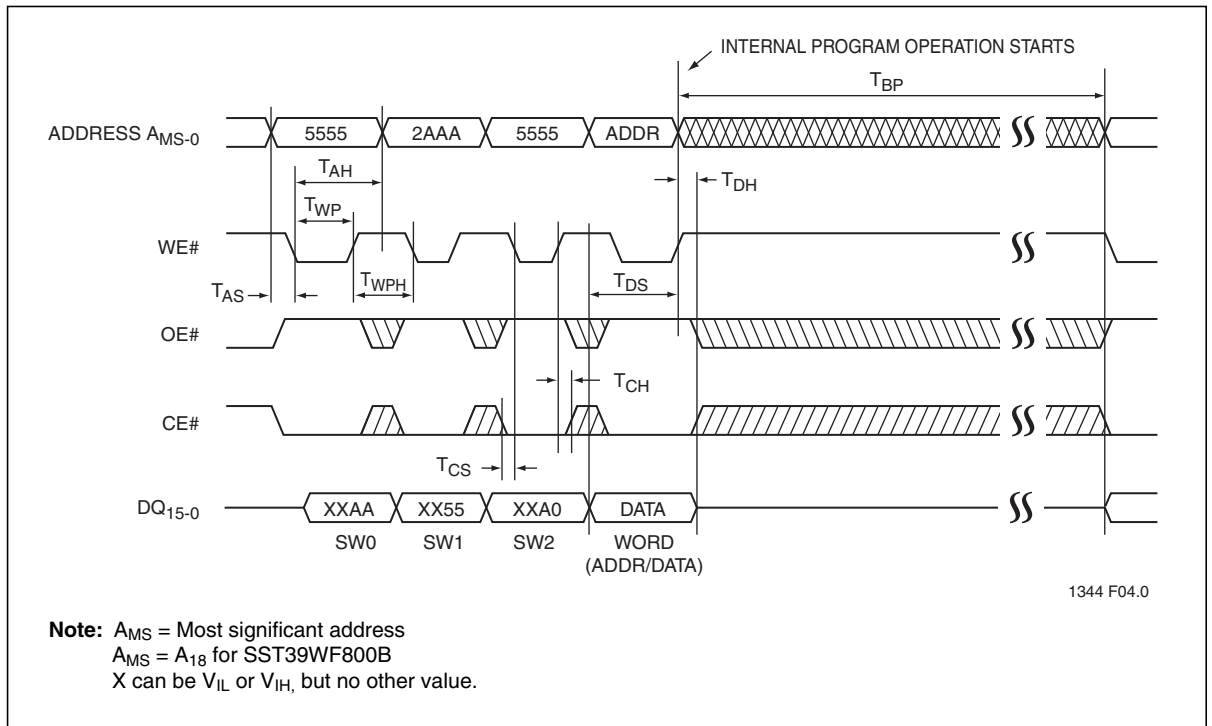

Figure 6: WE# Controlled Program Cycle Timing Diagram

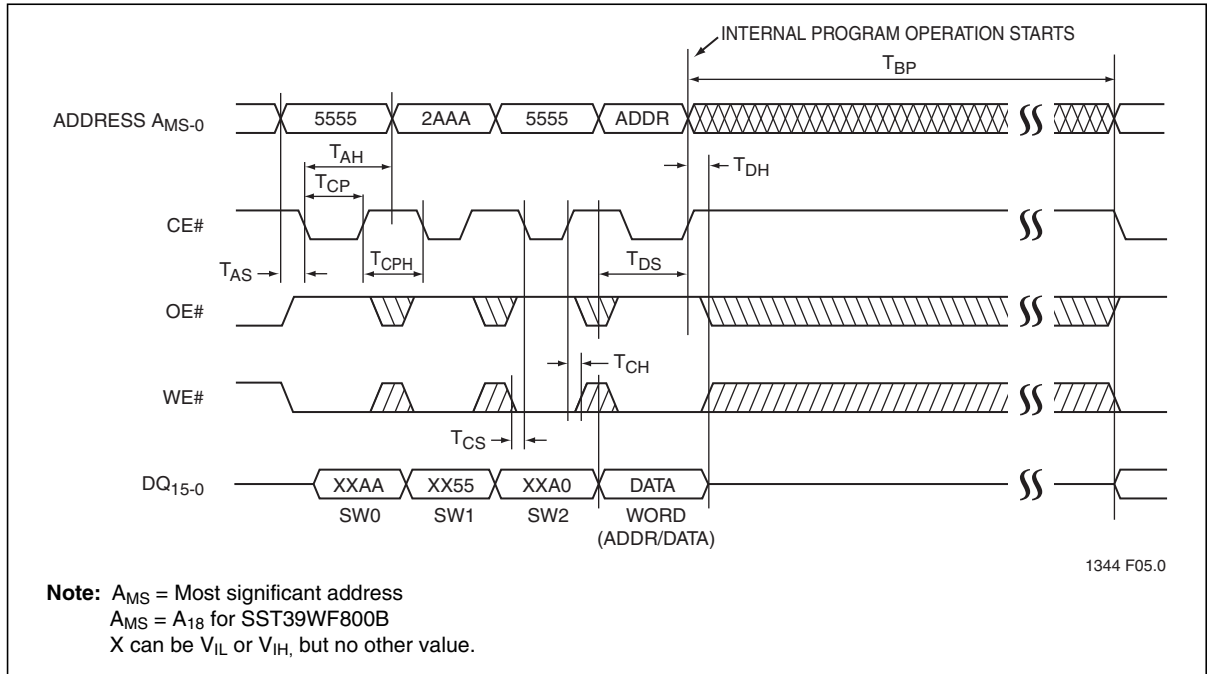

Figure 7: CE# Controlled Program Cycle Timing Diagram

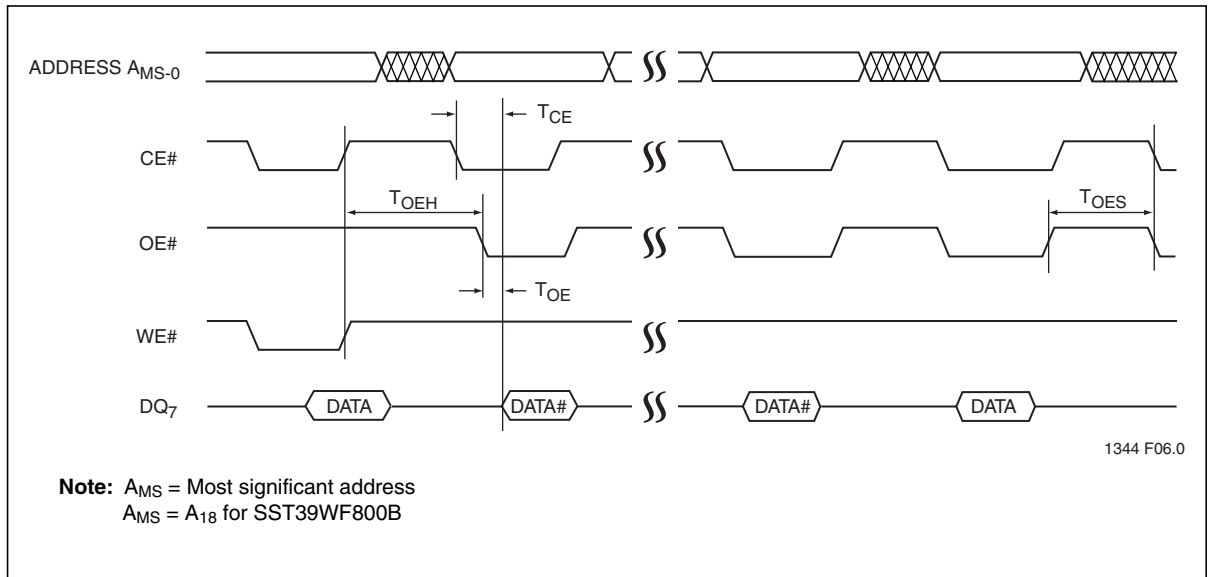

Figure 8: Data# Polling Timing Diagram

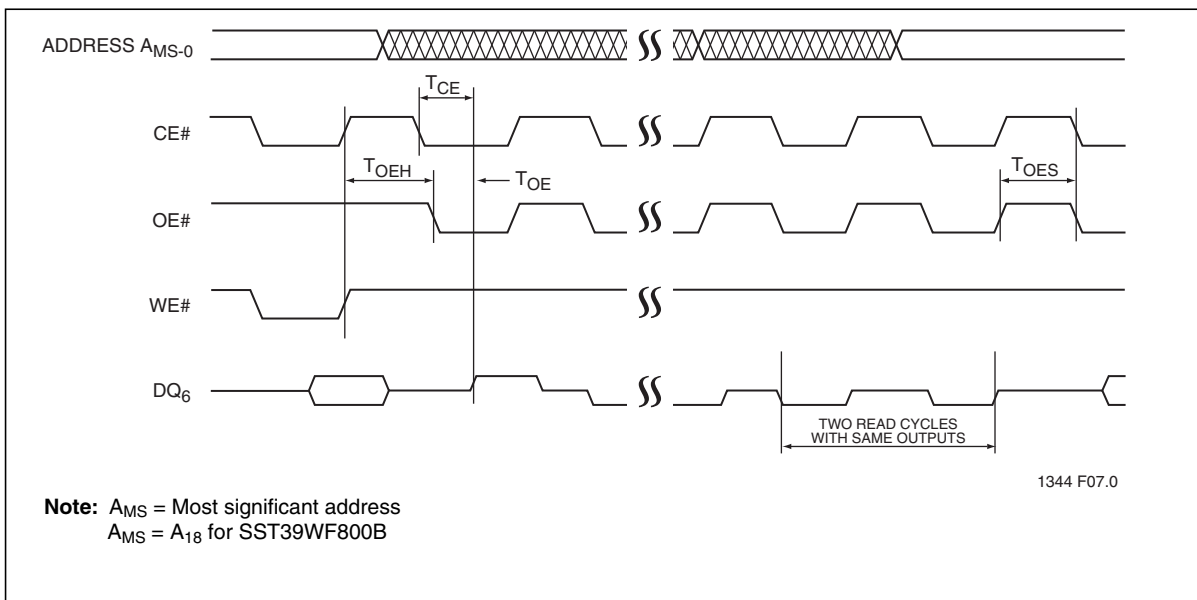

FIGURE 0-1: TOGGLE BIT TIMING DIAGRAM

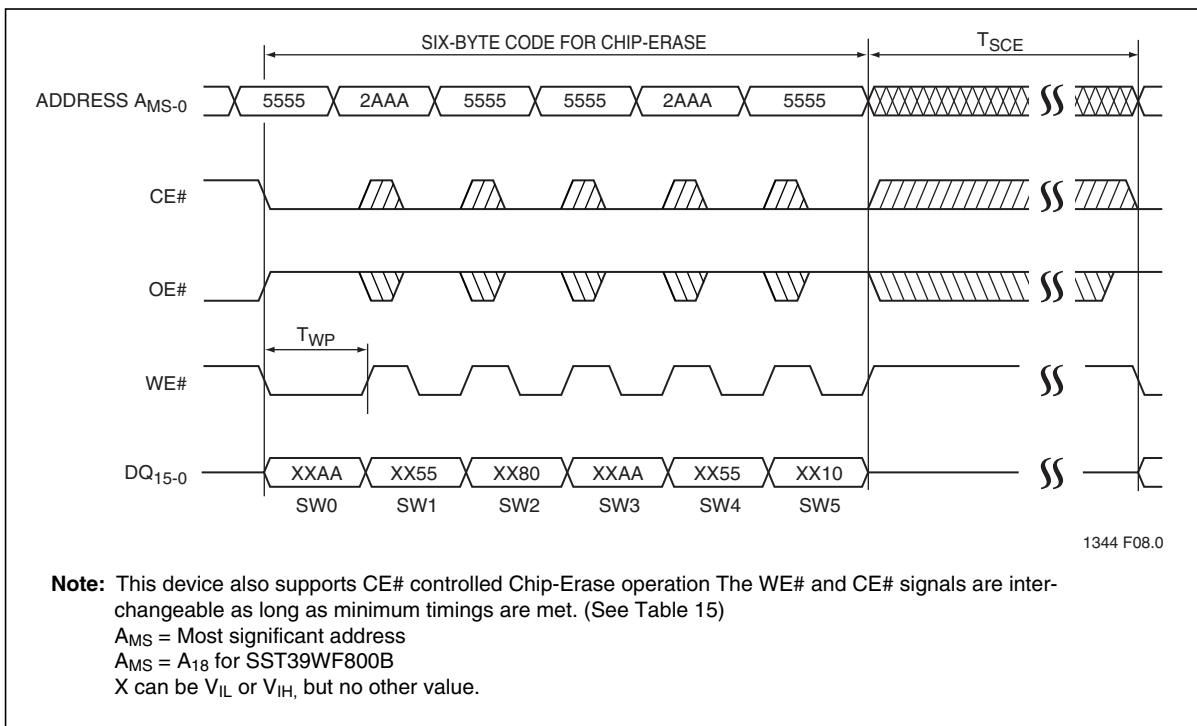

Figure 9: WE# Controlled Chip-Erase Timing Diagram

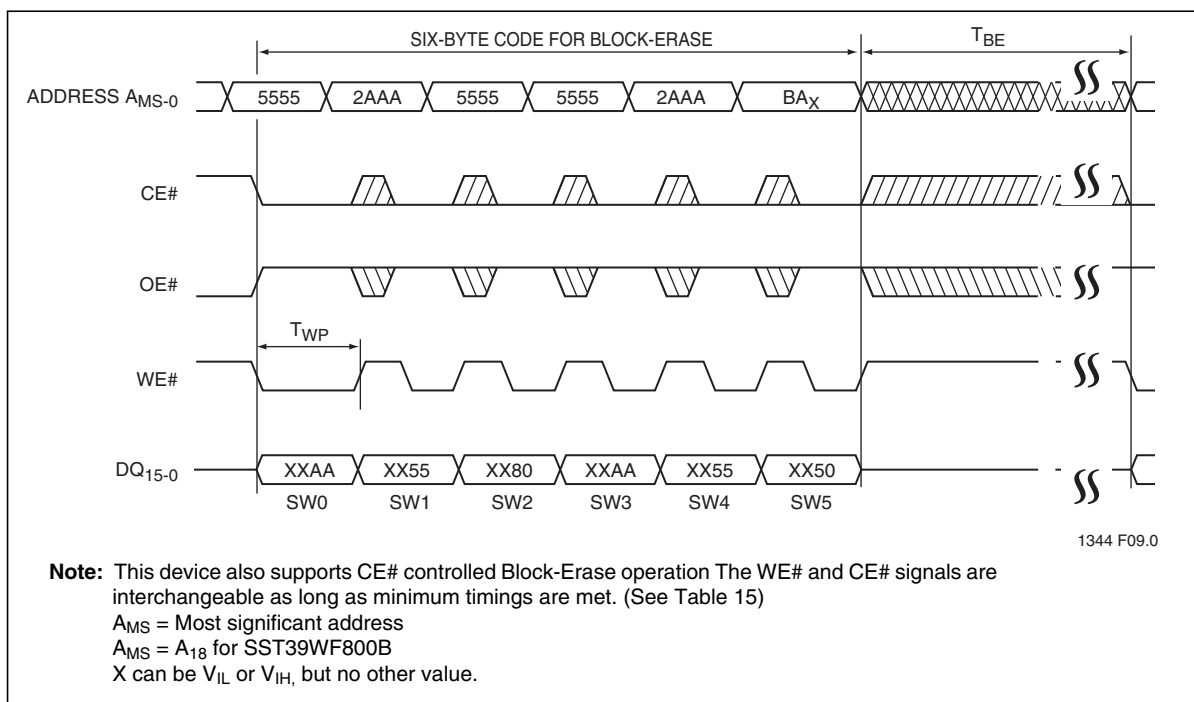

Figure 10: WE# Controlled Block-Erase Timing Diagram

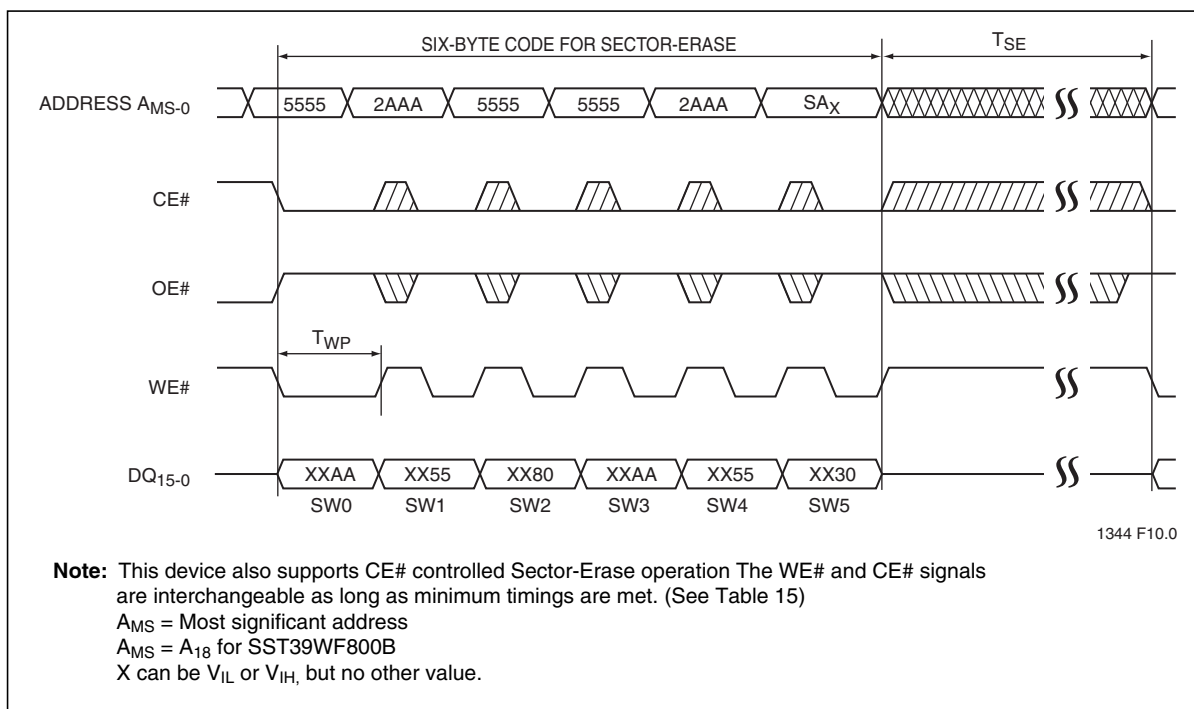

Figure 11: WE# Controlled Sector-Erase Timing Diagram

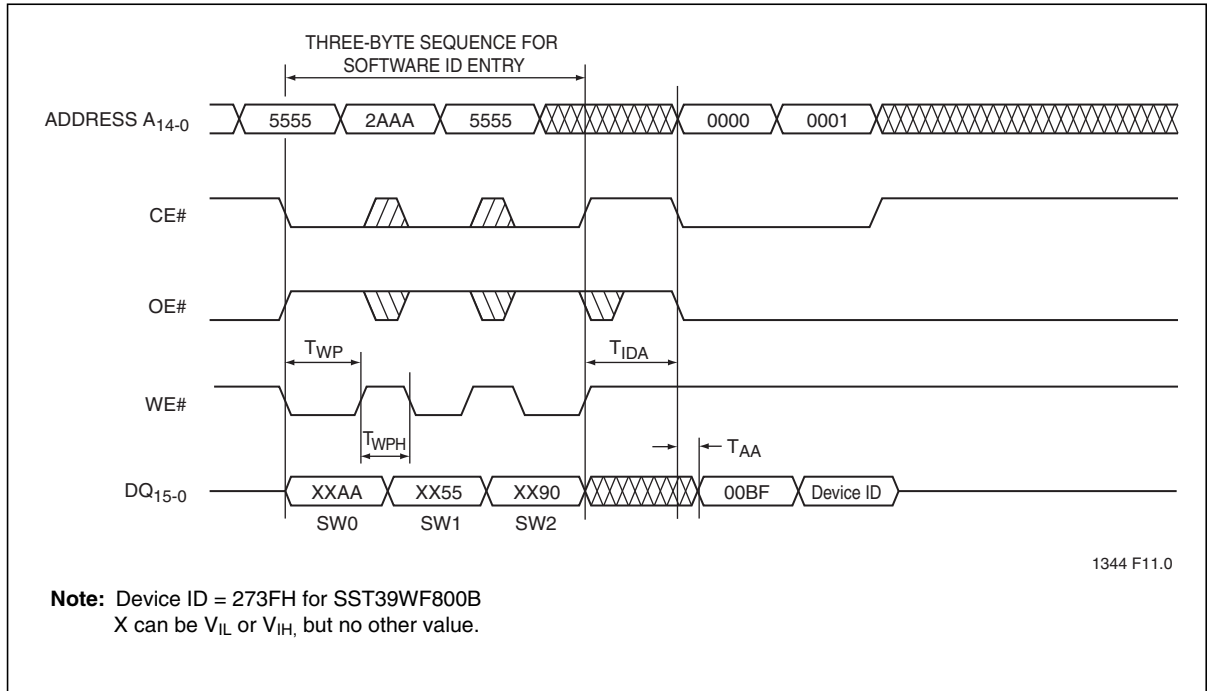

Figure 12: Software ID Entry and Read

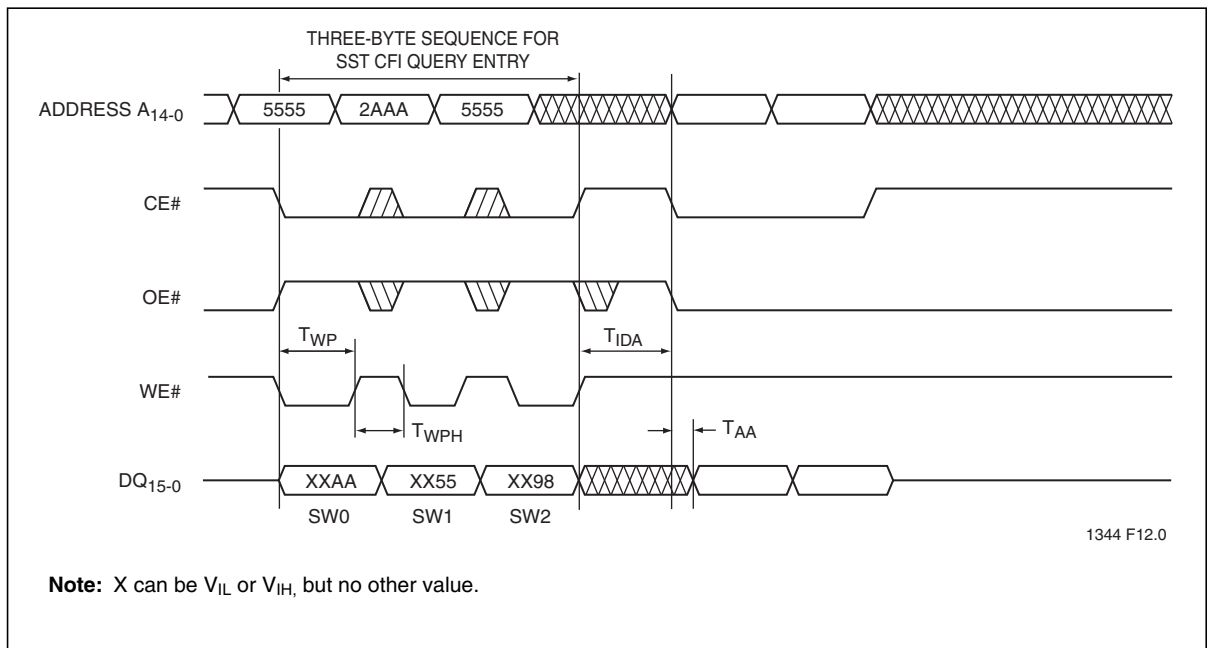

Figure 13: SST CFI Query Entry and Read

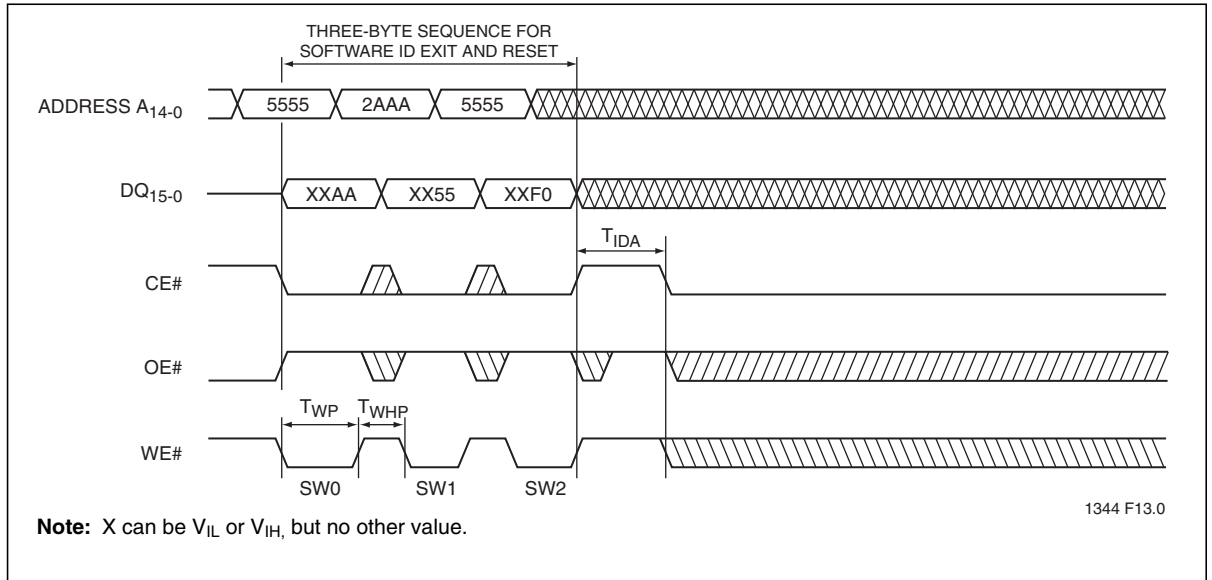

Figure 14: Software ID Exit/CFI Exit

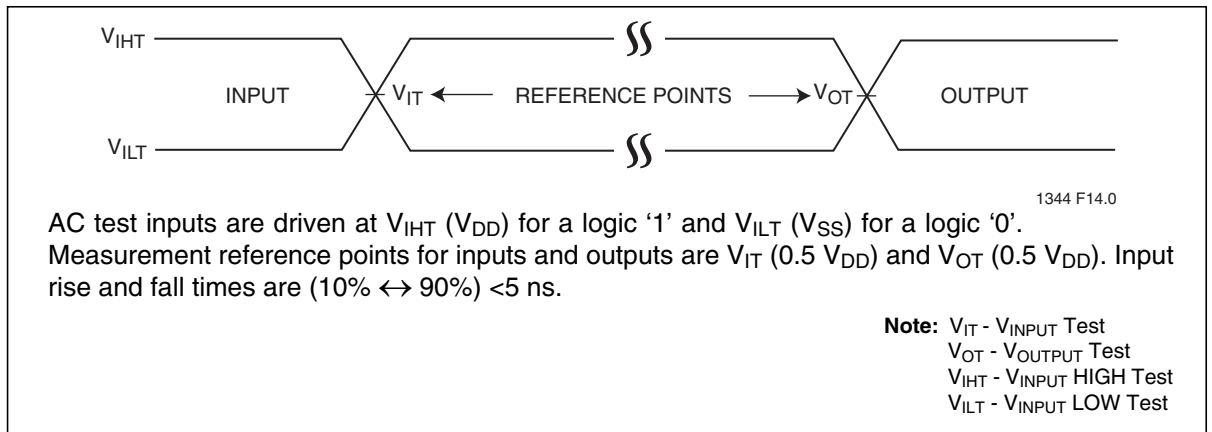

Figure 15: AC Input/Output Reference Waveforms

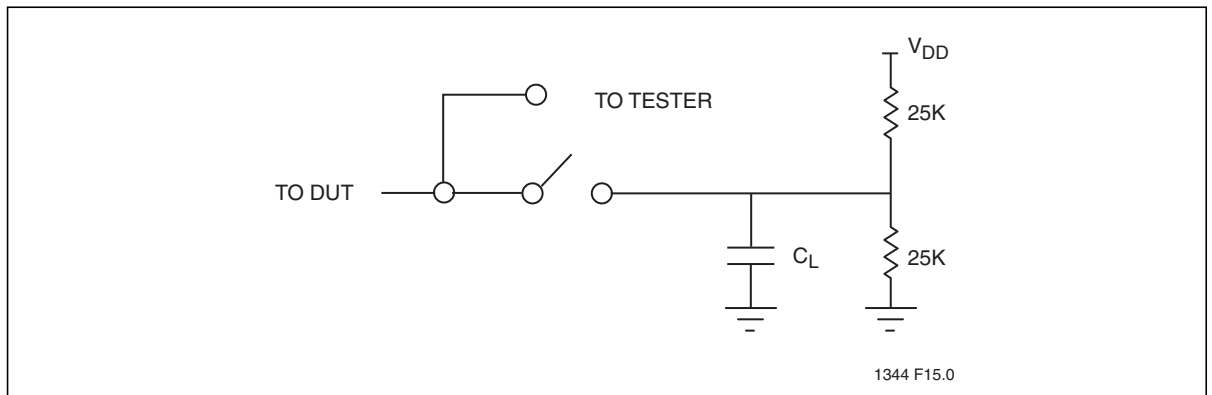

Figure 16:A Test Load Example

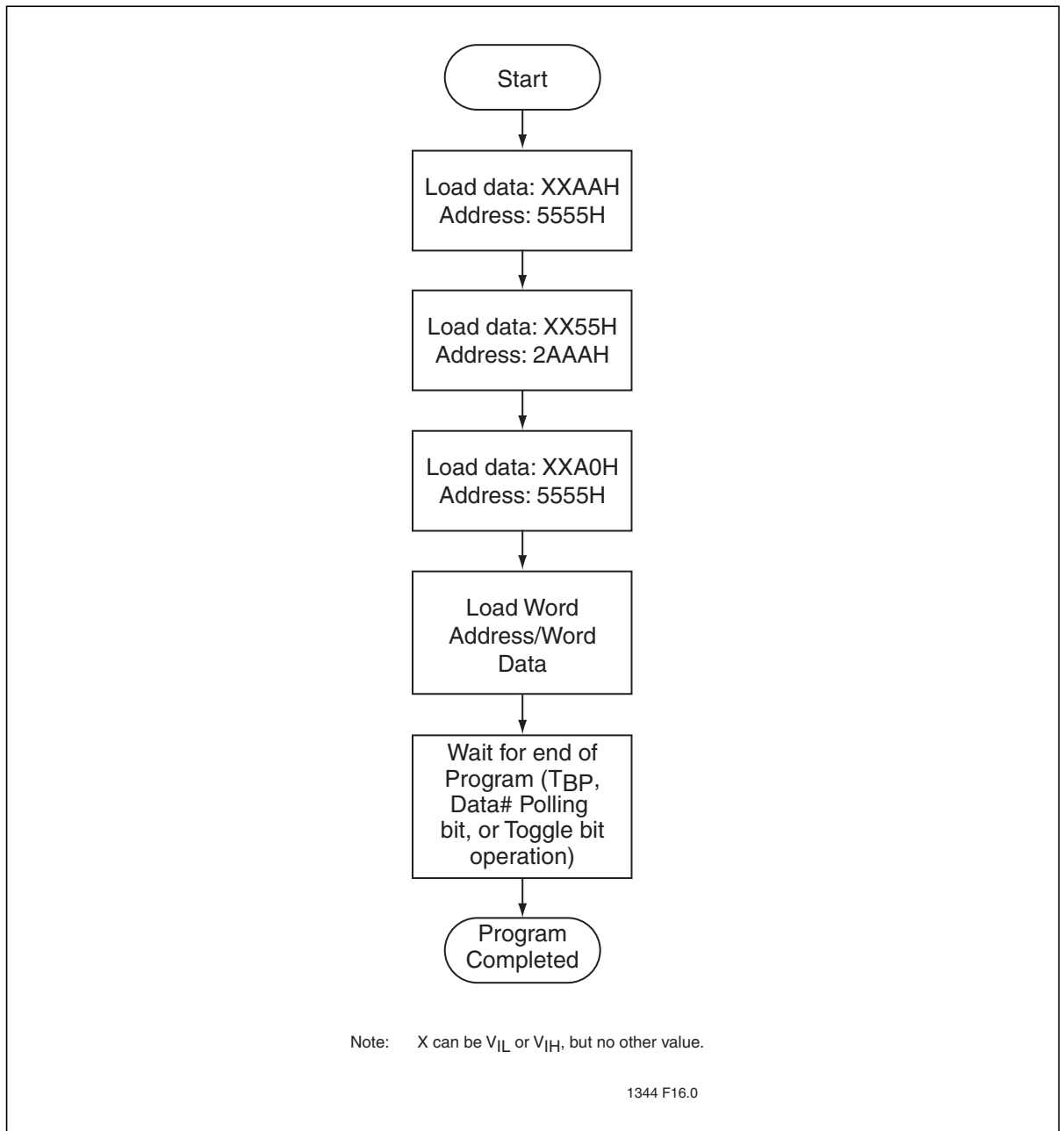

Figure 17: Word-Program Algorithm

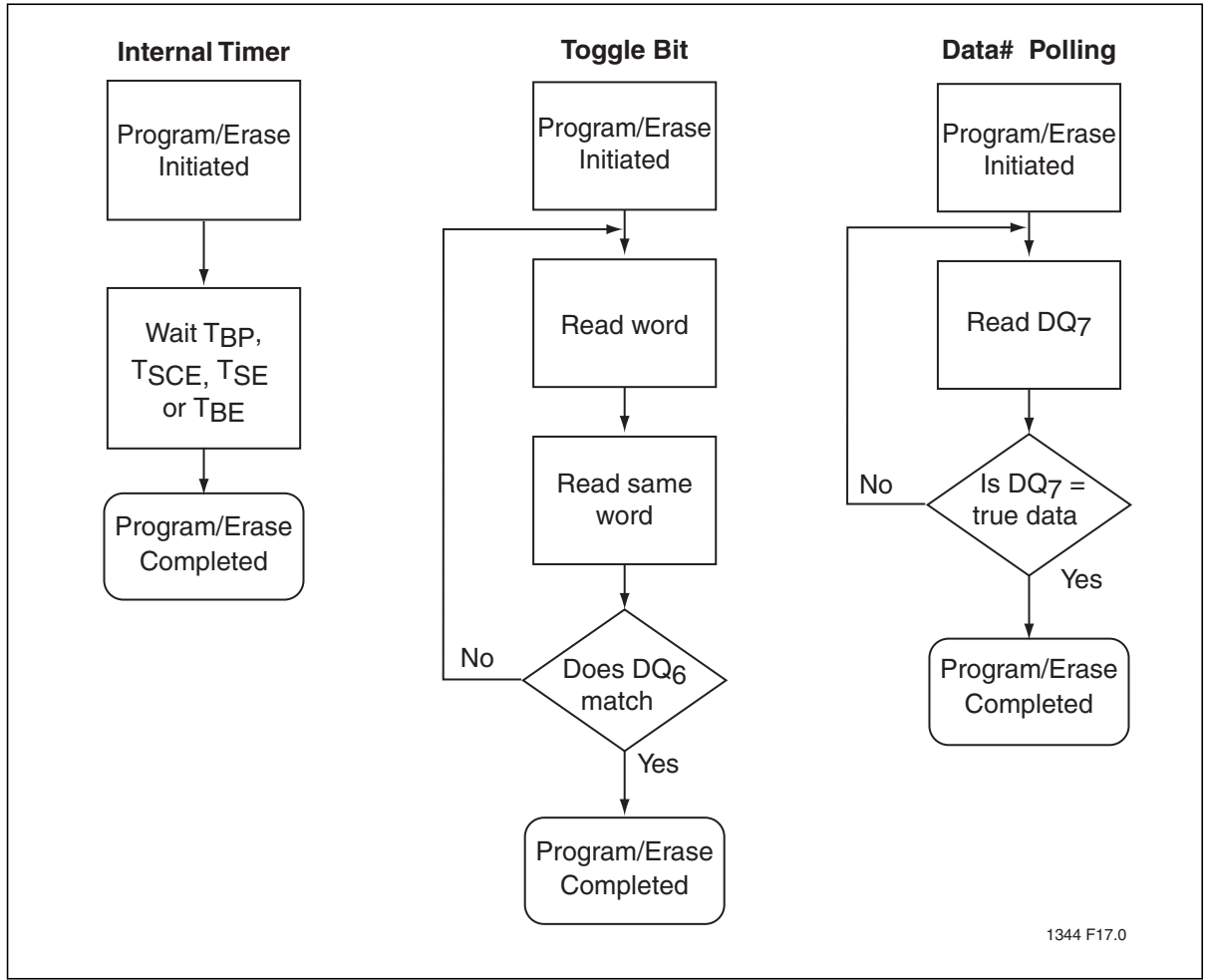

Figure 18: Wait Options

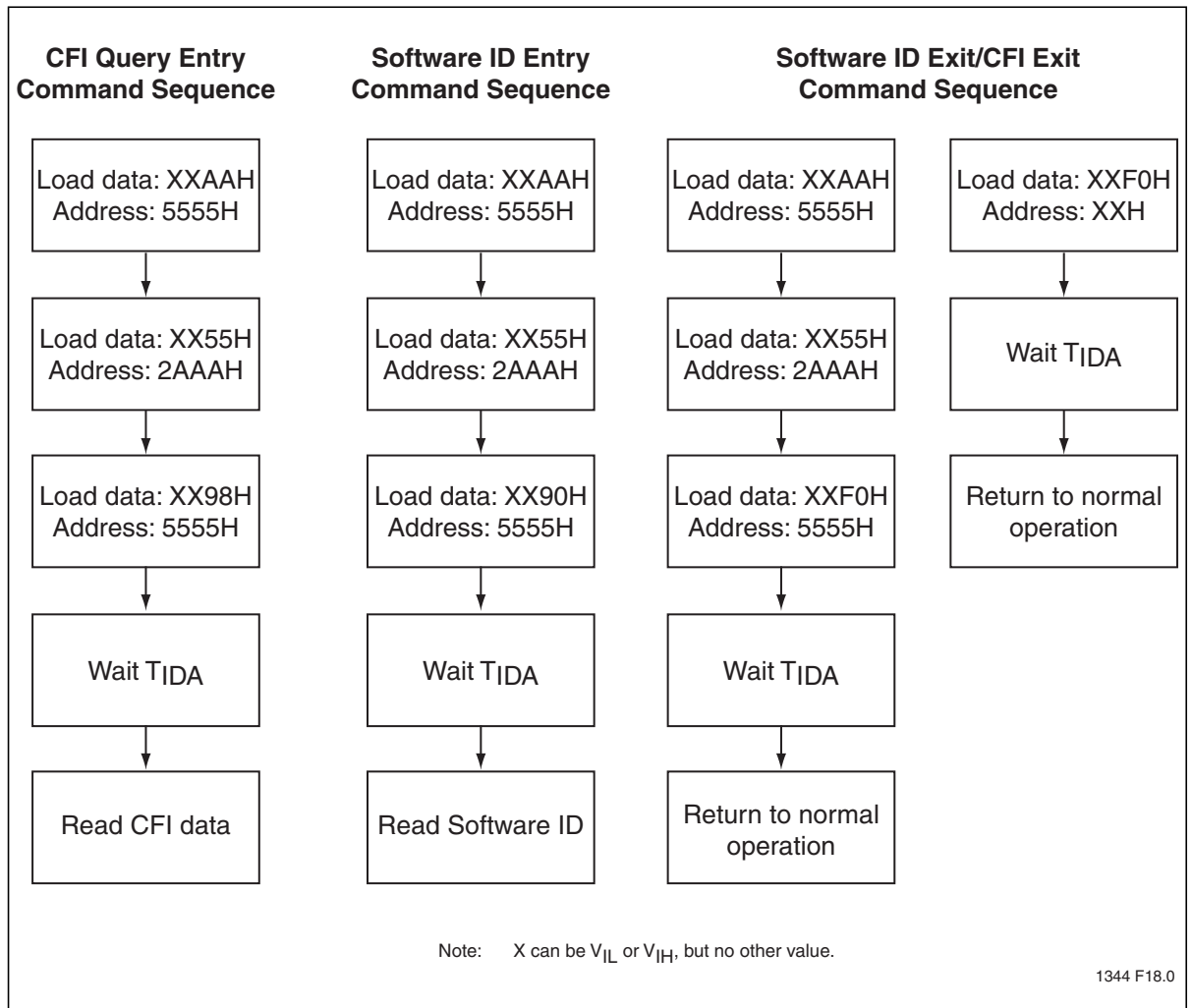

Figure 19: Software ID/CFI Command Flowcharts

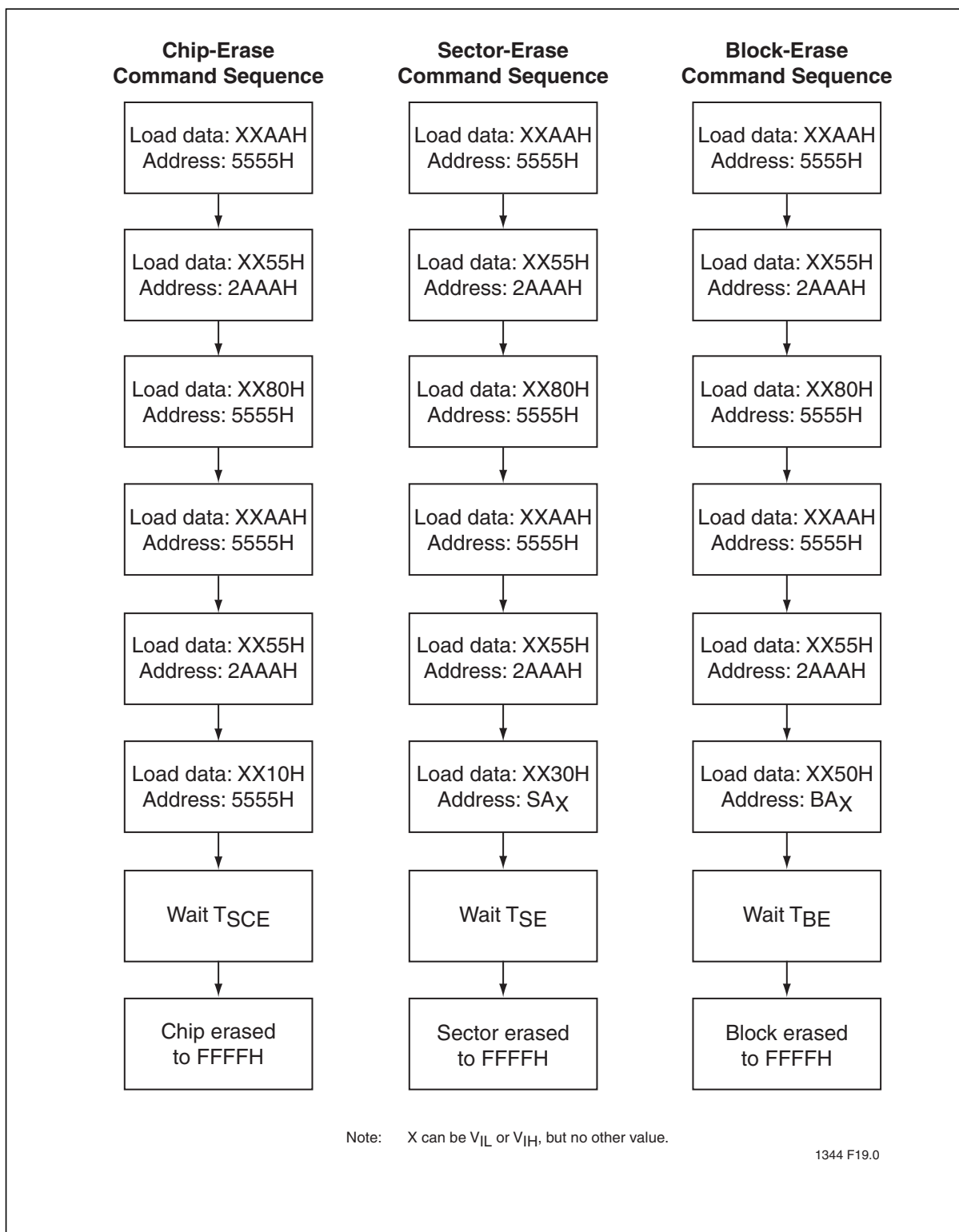
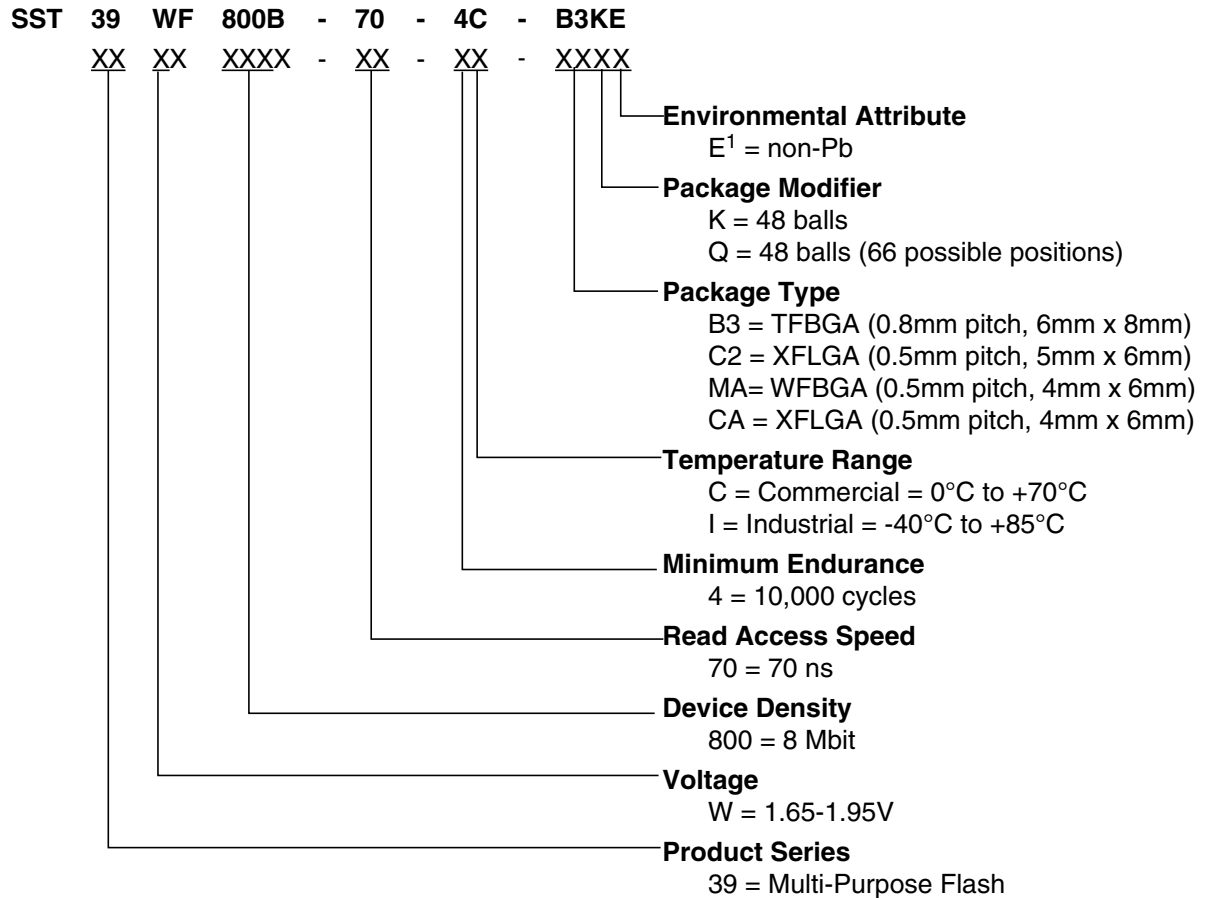

Figure 20: Erase Command Sequence



Product Ordering Information



1. Environmental suffix "E" denotes non-Pb solder.
SST non-Pb solder devices are "RoHS Compliant".

Valid combinations for SST39WF800B

SST39WF800B-70-4C-B3KE	SST39WF800B-70-4I-B3KE
SST39WF800B-70-4C-C2QE	SST39WF800B-70-4I-C2QE
SST39WF800B-70-4C-MAQE	SST39WF800B-70-4I-MAQE
SST39WF800B-70-4C-CAQE	SST39WF800B-70-4I-CAQE

Note: Valid combinations are those products in mass production or will be in mass production. Consult your SST sales representative to confirm availability of valid combinations and to determine availability of new combinations.



Packaging Diagrams

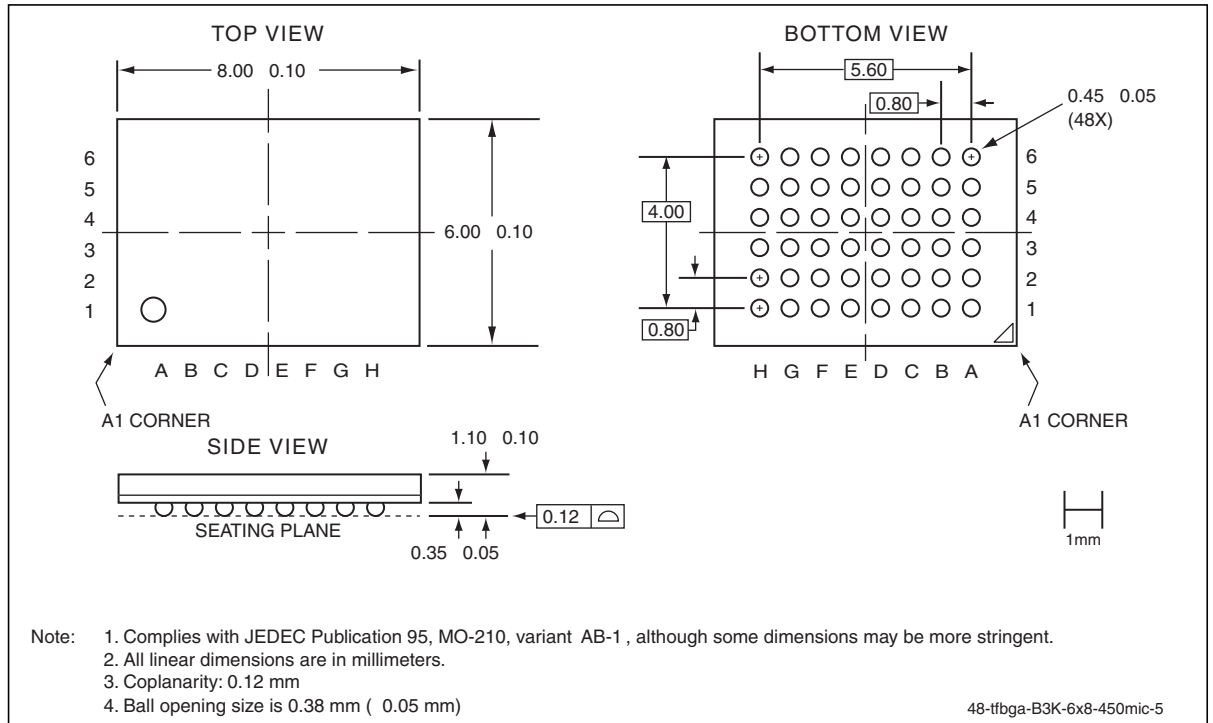

Figure 21: 48-Ball Thin-Profile, Fine-Pitch Ball Grid Array (TFBGA) 6mm x 8mm
SST Package Code: B3K

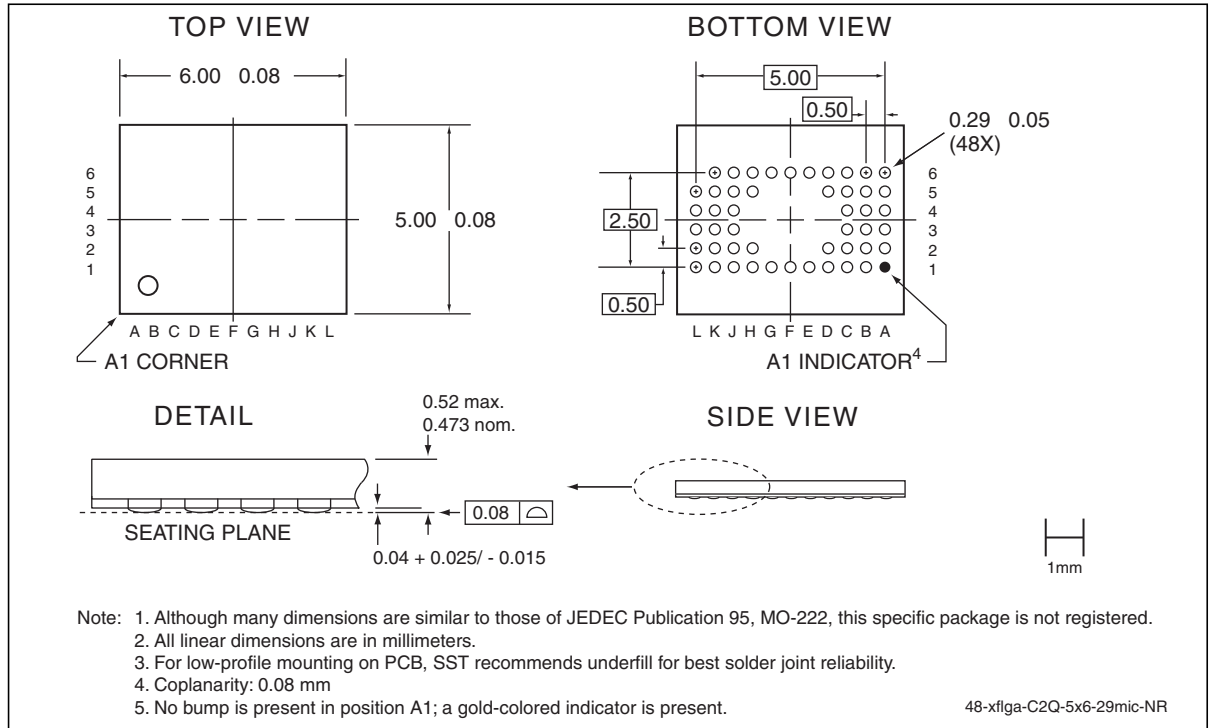

Figure 22: 48-Ball Extremely Thin-Profile, Fine-Pitch Land Grid Array (XFLGA) 5mm x 6mm
SST Package Code: C2Q



8 Mbit (x16) Multi-Purpose Flash SST39WF800B

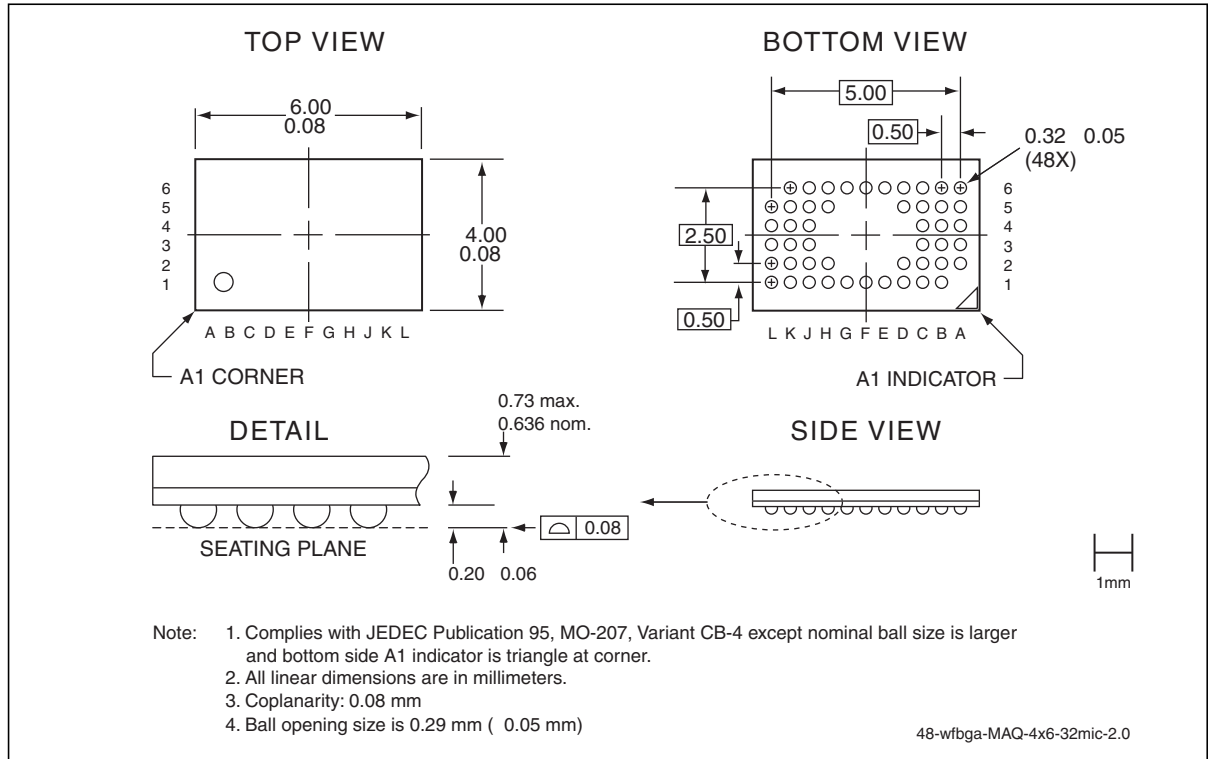

Figure 23: 48-Ball Very-Very-Thin-Profile, Fine-Pitch Ball Grid Array (WFBGA) 4mm x 6mm
SST Package Code: MAQ

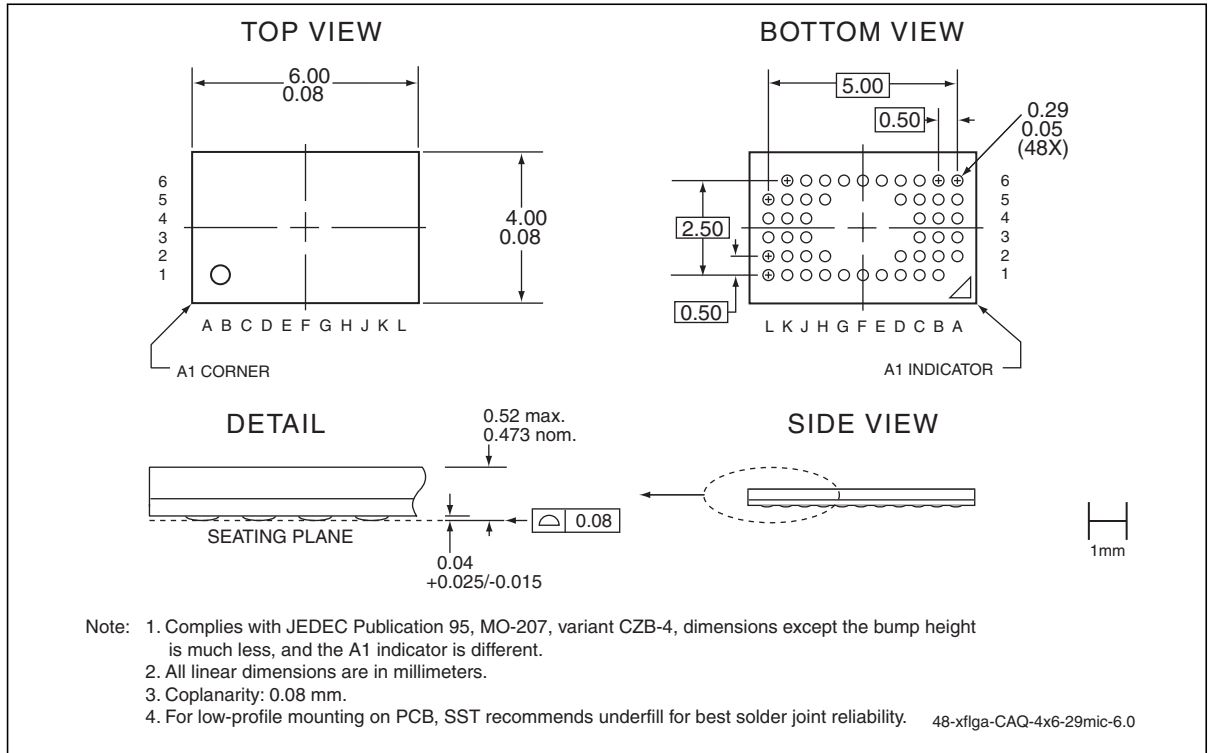

Figure 24: 48-Ball Extremely Thin-Profile, Fine-Pitch Land Grid Array (XFLGA) 4mm x 6mm
SST Package Code: CAQ



Table 16: Revision History

Number	Description	Date
00	<ul style="list-style-type: none"> Initial release of data sheet 	Feb 2007
01	<ul style="list-style-type: none"> Added "Power-Up Specifications" on page 14 Removed the M2QE and MBQE packages Added Y1QE package information 	Jul 2007
02	<ul style="list-style-type: none"> EOL of all Y1QE parts. Replacement parts are MAQE parts listed in this document. Added information for the MAQE and CAQE packages. 	Dec 2009
A	<ul style="list-style-type: none"> Applied new document format Released document under letter revision system Updated spec number from S71344 to DS25031 	Aug 2011

ISBN:978-1-61341-405-7

© 2011 Silicon Storage Technology, Inc—a Microchip Technology Company. All rights reserved.

SST, Silicon Storage Technology, the SST logo, SuperFlash, MTP, and FlashFlex are registered trademarks of Silicon Storage Technology, Inc. MPF, SQI, Serial Quad I/O, and Z-Scale are trademarks of Silicon Storage Technology, Inc. All other trademarks and registered trademarks mentioned herein are the property of their respective owners.

Specifications are subject to change without notice. Refer to www.microchip.com for the most recent documentation. For the most current package drawings, please see the Packaging Specification located at <http://www.microchip.com/packaging>.

Memory sizes denote raw storage capacity; actual usable capacity may be less.

SST makes no warranty for the use of its products other than those expressly contained in the Standard Terms and Conditions of Sale.

For sales office(s) location and information, please see www.microchip.com.

Silicon Storage Technology, Inc.
A Microchip Technology Company
www.microchip.com

Компания «Life Electronics» занимается поставками электронных компонентов импортного и отечественного производства от производителей и со складов крупных дистрибьюторов Европы, Америки и Азии.

С конца 2013 года компания активно расширяет линейку поставок компонентов по направлению коаксиальный кабель, кварцевые генераторы и конденсаторы (керамические, пленочные, электролитические), за счёт заключения дистрибьюторских договоров

Мы предлагаем:

- Конкурентоспособные цены и скидки постоянным клиентам.
- Специальные условия для постоянных клиентов.
- Подбор аналогов.
- Поставку компонентов в любых объемах, удовлетворяющих вашим потребностям.
- Приемлемые сроки поставки, возможна ускоренная поставка.
- Доставку товара в любую точку России и стран СНГ.
- Комплексную поставку.
- Работу по проектам и поставку образцов.
- Формирование склада под заказчика.
- Сертификаты соответствия на поставляемую продукцию (по желанию клиента).
- Тестирование поставляемой продукции.
- Поставку компонентов, требующих военную и космическую приемку.
- Входной контроль качества.
- Наличие сертификата ISO.

В составе нашей компании организован Конструкторский отдел, призванный помогать разработчикам, и инженерам.

Конструкторский отдел помогает осуществить:

- Регистрацию проекта у производителя компонентов.
- Техническую поддержку проекта.
- Защиту от снятия компонента с производства.
- Оценку стоимости проекта по компонентам.
- Изготовление тестовой платы монтаж и пусконаладочные работы.



Тел: +7 (812) 336 43 04 (многоканальный)

Email: org@lifeelectronics.ru