



The AA Outdoor Cooler Series is an air-to-air thermoelectric assembly (TEA) that uses impingement flow to transfer heat. It offers dependable, compact performance by cooling objects via convection. Heat is absorbed and dissipated thru high density heat exchangers equipped with air ducted shrouds and brand name fans. The heat pumping action occurs from custom designed thermoelectric modules that achieve a high coefficient of performance (COP) to minimize power consumption.

This product series has been designed to pass rigorous Telcordia test requirements conducted by our customers, such as earthquake resistance, salt fog, wind-driven rain, high temperature exposure and dust contaminants. This is due to the selection of world-class components such as brand fans with the highest degree of environmental protection and lifetime guaranteed waterproof connectors, heavy-duty anodization on the high-density heat sinks, overheat protection, and double environmental seals for the thermoelectric modules.

Patent No.: US 9,360,240

FEATURES

- 244W capacity rated at $\Delta T = 0^{\circ}\text{C}$, $T_{\text{ambient}} = 35^{\circ}\text{C}$
- Wide operating temperature range of -40°C to $+55^{\circ}\text{C}$
- Telcordia GR-487-CORE tested and verified by customers when integrated in telecom outdoor enclosures
- UL60950 and UL50 approval obtained by customers when integrated in telecom outdoor enclosure
- Environmentally friendly solid-state operation
 - no compressor or CFC refrigerants
- Cooling and heating in the same unit; optional temperature controller reverses the polarity of current to generate heating

APPLICATIONS

- Outdoor telecom enclosures
- Outdoor kiosks and displays
- Harsh condition electronic cabinets
- Battery cabinets

TECHNICAL SPECIFICATIONS

Technology	Thermoelectric modules, forced air, closed loop (non-mixing), filter less, non-refrigerant
Cooling at $dT = 0^{\circ}\text{C}$, and nominal / float voltage ¹ - W	244/262 (832/894 BTU/hr)
Heating (calculated) ² - W	250 (853 Btu/h)
Voltage, nominal / maximum ⁴ -VDC	48/60
COP (Coefficient of Performance) - %	85
Grounding (all voltages)	Positive or negative
Current draw, nominal / start-up $\pm 10\%$ - A	6.1/7.8
Weight - kg (lbs)	6.3 (16.9)
Panel mounting	Through (from external side)
Fan life (L_{10} at $+40^{\circ}\text{C}$)	$\geq 70,000$ hours
Connector type (on unit / mating side)	Terminal block with cage clamps (AWG 28-12)
Hi-pot testing - VDC	707

ENVIRONMENTAL

Temperature range ³ , external ambient - °C (°F)	-40 to +55 (-40 to +131)
Temperature range, internal enclosure - °C (°F)	-20 to +55 (-4 to +131)
Degree of protection, unit ⁵	IP54
Degree of protection, unit ext. side ⁵	IP54
Sound level, 1 m distance - dB(A)	63
Over-Temp Thermostat	75°C ± 6°C (accessory)

1. Cooling capacities at nominal / float voltage are rated at external temperatures of +35°C and +50°C respectively. Float voltage is defined at 27 VDC.
2. Calculated heating capacity is rated at external temperature of -40°C, nominal voltage, and $\Delta T = -45^\circ\text{C}$.
3. Controller function shall not operate the external fan during heating mode.
4. Max ripple 5%.
5. Rating for unit without protective shroud. A higher degree of protection can be obtained with external shroud.

PERFORMANCE QC VS ΔT

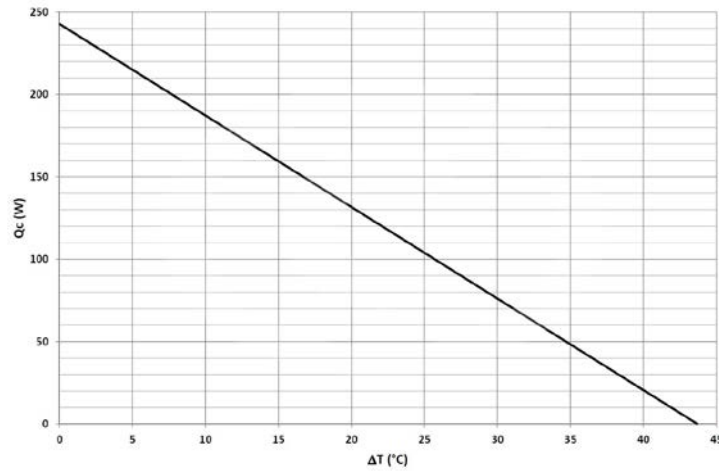

ISOMETRIC DRAWINGS

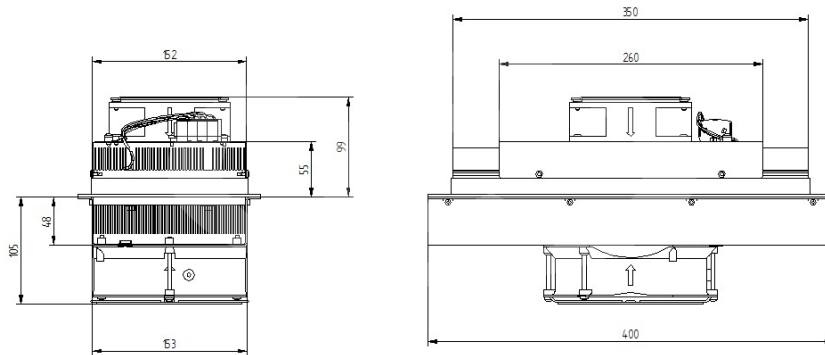

MOUNTING HOLE LOCATION & HANDWARE

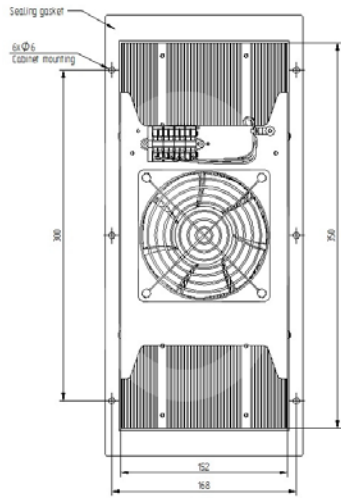

ELECTRICAL CONNECTIONS 24VDC (CAGE CLAMP)

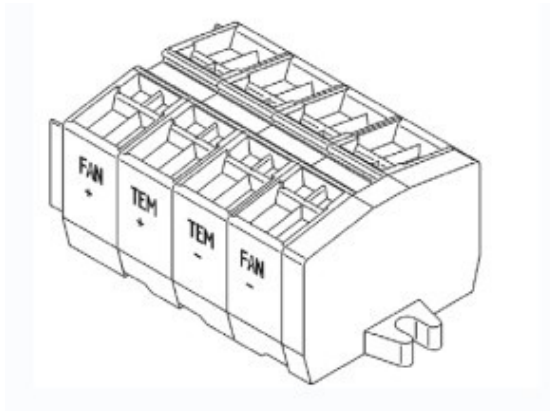

Americas: +1.919.597.7300
 Europe: +46.31.420530
 Asia: +86.755.2714.1166
 ets.sales@lairdtech.com
 www.lairdtech.com



Laird warrants to the original end user customer of its products that its products are free from defects in material and workmanship. Subject to conditions and limitations Laird will, at its option, either repair or replace any part of its products that prove defective because of improper workmanship or materials. This limited warranty is in force for the useful lifetime of the original end product into which the Laird product is installed. Useful lifetime of the original end product may vary but is not to exceed five (5) years from the original date of the end product purchase.

Any information furnished by Laird Inc. and its agents is believed to be accurate and reliable. All specifications are subject to change without notice. Responsibility for the use and application of Laird materials rests with the end user, since Laird and its agents cannot be aware of all potential uses. Laird makes no warranties as to the fitness, merchantability or suitability of any Laird materials or products for any specific or general uses. Laird shall not be liable for incidental or consequential damages of any kind. All Laird products are sold pursuant to the Laird Terms and Conditions of sale in effect from time to time, a copy of which will be furnished upon request.

© Copyright 2018 Laird Inc. All Rights Reserved. Laird, Laird Technologies, the Laird Logo, and other marks are trademarks or registered trademarks of Laird Inc. or an affiliate company thereof. Other product or service names may be the property of third parties. Nothing herein provides a license under any Laird or any third party intellectual property rights.

Компания «Life Electronics» занимается поставками электронных компонентов импортного и отечественного производства от производителей и со складов крупных дистрибьюторов Европы, Америки и Азии.

С конца 2013 года компания активно расширяет линейку поставок компонентов по направлению коаксиальный кабель, кварцевые генераторы и конденсаторы (керамические, пленочные, электролитические), за счёт заключения дистрибьюторских договоров

Мы предлагаем:

- Конкурентоспособные цены и скидки постоянным клиентам.
- Специальные условия для постоянных клиентов.
- Подбор аналогов.
- Поставку компонентов в любых объемах, удовлетворяющих вашим потребностям.
- Приемлемые сроки поставки, возможна ускоренная поставка.
- Доставку товара в любую точку России и стран СНГ.
- Комплексную поставку.
- Работу по проектам и поставку образцов.
- Формирование склада под заказчика.
- Сертификаты соответствия на поставляемую продукцию (по желанию клиента).
- Тестирование поставляемой продукции.
- Поставку компонентов, требующих военную и космическую приемку.
- Входной контроль качества.
- Наличие сертификата ISO.

В составе нашей компании организован Конструкторский отдел, призванный помогать разработчикам, и инженерам.

Конструкторский отдел помогает осуществить:

- Регистрацию проекта у производителя компонентов.
- Техническую поддержку проекта.
- Защиту от снятия компонента с производства.
- Оценку стоимости проекта по компонентам.
- Изготовление тестовой платы монтаж и пусконаладочные работы.



Тел: +7 (812) 336 43 04 (многоканальный)

Email: org@lifeelectronics.ru