

Switchcraft®

Sealed Power Plugs and Jacks



IP68/ NEMA 250 (6P) Sealed Power Plug and Jack

Applications:

- Outdoor power supplies where a weather resistant connection is needed
- Medical equipment where the power plug would need to be water proof
- Lighting connections where a rugged harsh environment connector would provide the most reliable sealed connection

Key Features:

- IP rating of IP68/ NEMA 250 (6P), for properly mated Switchcraft sealed jack and plug, makes the device perfect for harsh environments
- Available in multiple pin diameters
- Automatic switch over from AC to DC permitted by sleeve shunt spring
- Optional IP rated cap (JCAP) protects Jack when not in use
- 5A current rating (carry), up to 30V DC at 65°C
- Overmold options available
- Color coded plug finger

Switchcraft®
*Harsh Environment
Connectivity Solutions*



switchcraft.com

5555 N. Elston, Chicago, IL 60630
773-792-2700 - sales@switchcraft.com

Switchcraft®

Sealed Power Plugs and Jacks

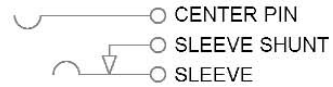
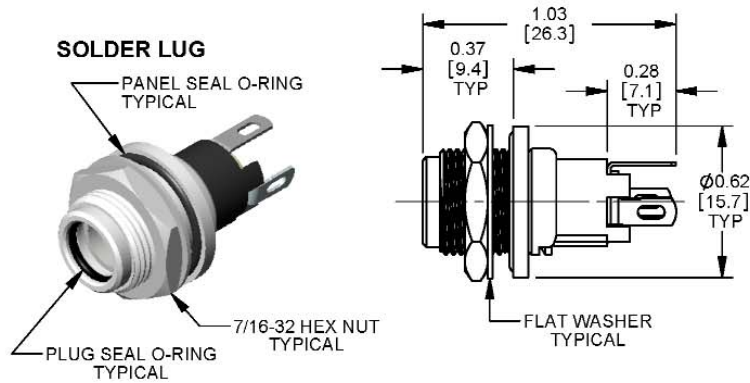

SCHEMATIC - TYPICAL

RECOMMENDED PANEL MTG HOLE:
 $\varnothing 0.440 \pm 0.002$ [11.18 ± 0.05] - TYPICAL

STRAIGHT PC

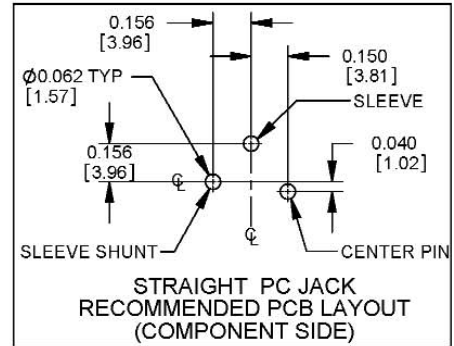
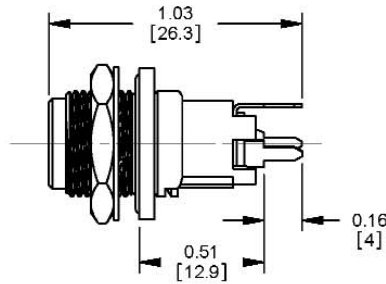

STRAIGHT PC JACK
 RECOMMENDED PCB LAYOUT
 (COMPONENT SIDE)

RIGHT-ANGLE PC

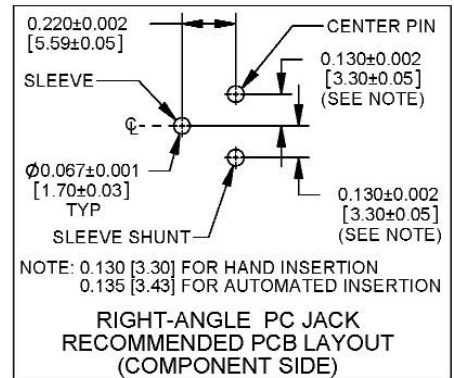
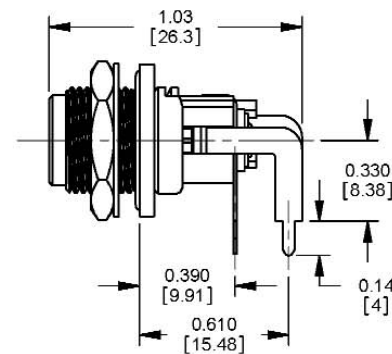

NOTE: 0.130 [3.30] FOR HAND INSERTION
 0.135 [3.43] FOR AUTOMATED INSERTION

RIGHT-ANGLE PC JACK
 RECOMMENDED PCB LAYOUT
 (COMPONENT SIDE)



OPTIONAL SEAL CAP - TYPICAL
 ORDERED SEPARATELY
 P/N: JCAP

DIMENSIONS SHOWN FOR REFERENCE ONLY, inches [mm]

Part Number	Center Pin/ Jack Size	Terminal Type	Mating Power Plug
L712AS	0.10 [2.5]	Solder Lugs	761KS12, 761KS15, 761KS17
PCL712AS		Straight PC	
L712RAS		Right-angle PC	
L722AS	0.08 [2.0]	Solder Lugs	S761KS12, S761KS15, S761KS17, 767KS12, 767KS15, 767KS17
PCL722AS		Straight PC	
L722RAS		Right-angle PC	
JCAP	Power Jack Seal Cap		

Switchcraft®
 Harsh Environment
 Connectivity Solutions



switchcraft.com
 5555 N. Elston, Chicago, IL 60630
 773-792-2700 - sales@switchcraft.com

Switchcraft®

Sealed Power Plugs and Jacks

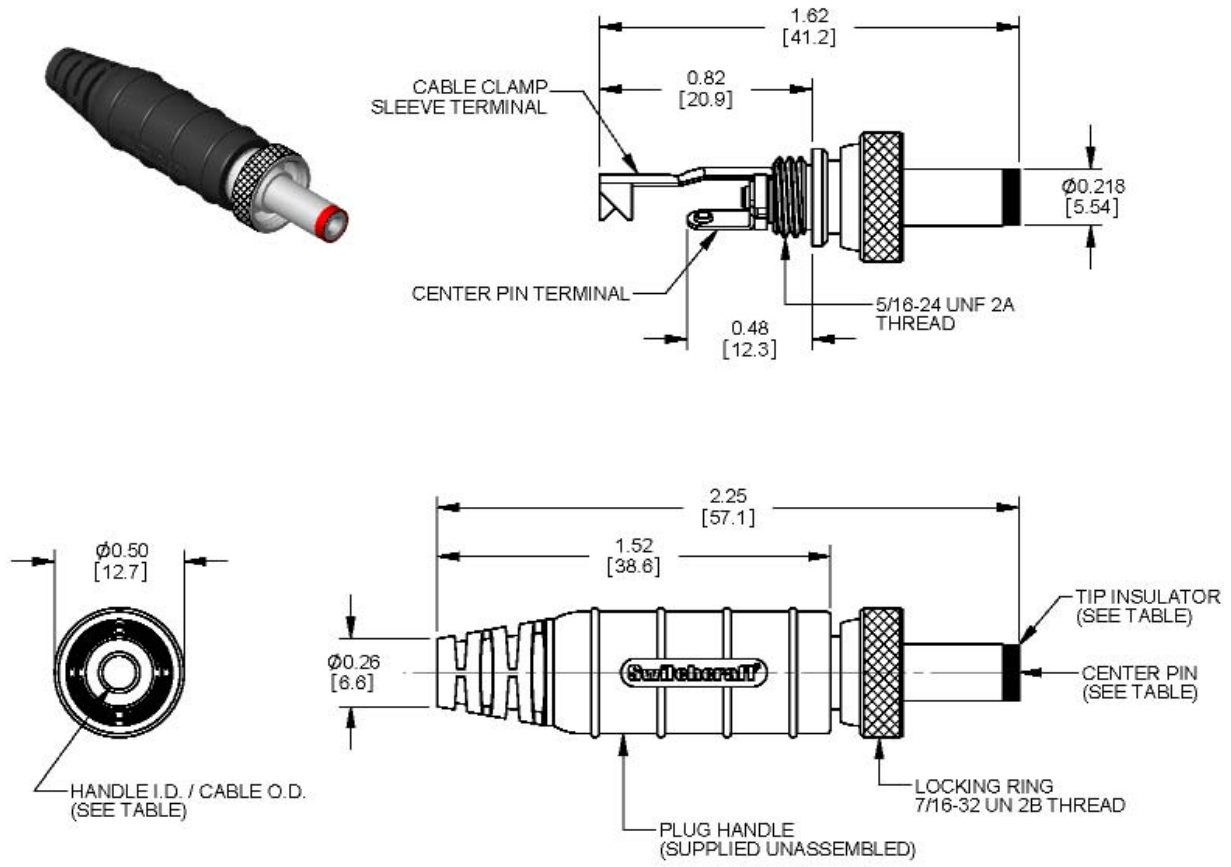

DIMENSIONS SHOWN FOR REFERENCE ONLY, inches [mm]

Part Number	Center Pin I.D./ Plug Size	Tip Insulator Color	Cable Nominal O.D. Range	Mating Power Jacks
761KS12	0.10 [2.5]	Black	0.125 - 0.150 [3.2 - 3.8mm]	L712AS, L712RAS, PCL712AS
761KS15		Black	0.150 - 0.175 [3.8 - 4.4mm]	
761KS17		Black	0.175 - 0.200 [4.4 - 5.1mm]	
S761KS12	0.08 [2.0]	White	0.125 - 0.150 [3.2 - 3.8mm]	L722AS, L722RAS, PCL722AS
S761KS15		White	0.150 - 0.175 [3.8 - 4.4mm]	
S761KS17		White	0.175 - 0.200 [4.4 - 5.1mm]	
767KS12	0.084 [2.1]	Red	0.125 - 0.150 [3.2 - 3.8mm]	
767KS15		Red	0.150 - 0.175 [3.8 - 4.4mm]	
767KS17		Red	0.175 - 0.200 [4.4 - 5.1mm]	

Switchcraft®
 Harsh Environment
 Connectivity Solutions



switchcraft.com
 5555 N. Elston, Chicago, IL 60630
 773-792-2700 - sales@switchcraft.com

Switchcraft®

Sealed Power Plugs and Jacks

Power Jack - Specifications

Features:

- IP66, IP67, IP68 / NEMA 250 (6P) when mated
- Automatic switch over from AC to DC permitted by sleeve shunt spring
- Split center pin shaped to hold mating plug firmly
- Right Angle versions offer “kinked” PC terminals for board retention
- Optional IP rated cap (JCAP) protects jack when not in use

Materials:

- Housing: Rigid thermoplastic
- Bushing: Plated copper alloy, with assembled & lubricated o-ring
- Terminals: Plated copper alloy
- Insulators: Rigid Thermoplastic
- Hardware: Supplied with one nickel plated copper alloy hex nut (P1489), one nickel plated steel flat washer (P3031) and one o-ring for sealing jack to panel

Electrical:

- Current Rating (carry): 5A, up to 30V DC at 65°C
- Contact Resistance: 0.01 Ohms max (initial), 0.02 Ohms (after humidity, durability exposure), 0.10 Ohms max. (after salt spray)
- Insulation Resistance: 10,000 Mohms min. (initial), 1,000 Mohms (after humidity, durability exposure)
- Dielectric Withstanding Voltage: 500VAC max.

Seal Cap - Specifications

Features:

- IP66, IP67, IP68 / NEMA 250 (6P) when mated

Material:

Thermoplastic Elastomer

Power Plug - Specifications

Features:

- IP66, IP67, IP68 / NEMA 250 (6P) when mated
- Hollow center pin available in 3 pin diameters (2.5mm, 2.1mm, 2.0mm)
- Locking ring provides security in critical applications
- Sleeve terminal serves as cord clamp
- Handle/Boot with cable strain relief

Specifications:

- Plug Sleeve and Pin: Plated copper alloy
- Lock Ring: Plated copper alloy
- Lock Ring Thread Size: 7/16-32 UN2B thread
- Finger Insulator: Rigid thermoplastic
- Insulating Washer: Rigid thermoplastic
- Sleeve Terminal: Plated copper alloy, electro-tinned
- Handle: Rigid thermoplastic overmolded with thermoplastic elastomer
- Handle Thread Size: 5/16-24 UNF 2A
- Electrical: Current (carry) 5A at 65°C

Overmold Option

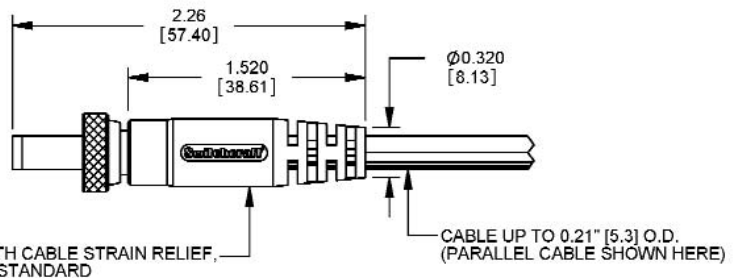

DIMENSIONS SHOWN FOR REFERENCE ONLY, inches [mm]

Switchcraft®
Harsh Environment
Connectivity Solutions



switchcraft.com
5555 N. Elston, Chicago, IL 60630
773-792-2700 - sales@switchcraft.com

Компания «Life Electronics» занимается поставками электронных компонентов импортного и отечественного производства от производителей и со складов крупных дистрибьюторов Европы, Америки и Азии.

С конца 2013 года компания активно расширяет линейку поставок компонентов по направлению коаксиальный кабель, кварцевые генераторы и конденсаторы (керамические, пленочные, электролитические), за счёт заключения дистрибьюторских договоров

Мы предлагаем:

- Конкурентоспособные цены и скидки постоянным клиентам.
- Специальные условия для постоянных клиентов.
- Подбор аналогов.
- Поставку компонентов в любых объемах, удовлетворяющих вашим потребностям.
- Приемлемые сроки поставки, возможна ускоренная поставка.
- Доставку товара в любую точку России и стран СНГ.
- Комплексную поставку.
- Работу по проектам и поставку образцов.
- Формирование склада под заказчика.
- Сертификаты соответствия на поставляемую продукцию (по желанию клиента).
- Тестирование поставляемой продукции.
- Поставку компонентов, требующих военную и космическую приемку.
- Входной контроль качества.
- Наличие сертификата ISO.

В составе нашей компании организован Конструкторский отдел, призванный помогать разработчикам, и инженерам.

Конструкторский отдел помогает осуществить:

- Регистрацию проекта у производителя компонентов.
- Техническую поддержку проекта.
- Защиту от снятия компонента с производства.
- Оценку стоимости проекта по компонентам.
- Изготовление тестовой платы монтаж и пусконаладочные работы.



Тел: +7 (812) 336 43 04 (многоканальный)
Email: org@lifeelectronics.ru