

3M™ RJS Series Rejacketing Sleeves

Data Sheet

August 2014

CAUTION

Working around energized high-voltage systems may cause serious injury or death. Installation should be performed by personnel familiar with good safety practice in handling high-voltage electrical equipment. De-energize and ground all electrical systems before installing product.

Product Description

3M™ RJS Series Rejacketing Sleeve assemblies are designed so that 3M™ Cold Shrink QTIII and QTII Silicone Rubber Terminations can be used on 3/C (three conductor) medium voltage (35 kV and less) shielded power cables with tape shield, wire shield, armored and non-armored configurations.

The RJS Series Rejacketing Sleeve Assemblies are:

- A series of silicone rubber insulators incorporating an inner expandable polyester braid designed to reduce sliding friction and deliver the insulator onto the cable.
- Designed to protect the phase legs (core) of 3/C shielded power cable from exposure to moisture, corrosion, ozone, ultra-violet radiation, physical contact and other hazards that are associated with termination operating environments.
- Designed to be used in conjunction with 3M Cold Shrink Breakout Boots and Silicone Rubber Terminations.

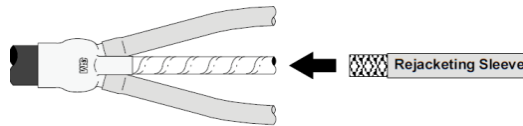

Kit Configurations

- 1- Poly-bagged four-foot continuous length assembly with inner polyester braid; ten poly bags per carton.
- 1- Poly-bagged six-foot continuous length assembly with inner polyester braid; ten poly bags per carton.
- 1- Poly-bagged ten-foot continuous length assembly with inner polyester braid; one poly bag per carton.

Continuous length assemblies are easily trimmed to length to meet field determined installation requirements.

3M™ RJS Series Rejacketing Sleeves

Features

- Versatile: installs quickly and accommodates a wide range of cable sizes.
- Simple hand application: no need for special installation tools.
- No torches or heat required.
- Excellent resistance to ozone and ultra-violet radiation.
- Good solvent resistance: compatible with industry approved cable cleaners.
- Excellent thermal stability.
- High dry and wet insulation resistance.
- Excellent shelf life.
- Easy to adjust sleeve length: adapts to variable equipment connection and mounting requirements.
- Compatible with 3M Cold Shrink Breakout Boots and Termination Products.

Applications

RJS Series Rejacketing Sleeve Assemblies :

- Are used to protect shielded phase legs (cores) of 3/C medium voltage (35 kV and less) power cables after the jacket has been removed in preparation for terminating.
 - Accommodate cable sizes ranging from 8 AWG (8 mm²) @ 3.3 kV to 750 kcmil (325 mm²) @ 35 kV.
 - Are available in six sizes to cover cable metallic shield diameters ranging from 0.43" (10,9 mm) to 1.91" (48,5 mm).
 - Termination designs incorporating 3M™ 3/C Phase Rejacketing System RJS Series sleeve assemblies can be field tested using normal cable testing procedures (reference: ANSI/IEEE Standard 400 "Guide for Field Testing and Evaluation of the Insulation of Shielded Power Cable Systems". Refer to most recent version.).
-

3M™ RJS Series Rejacketing Sleeves

Typical Physical and Electrical Properties

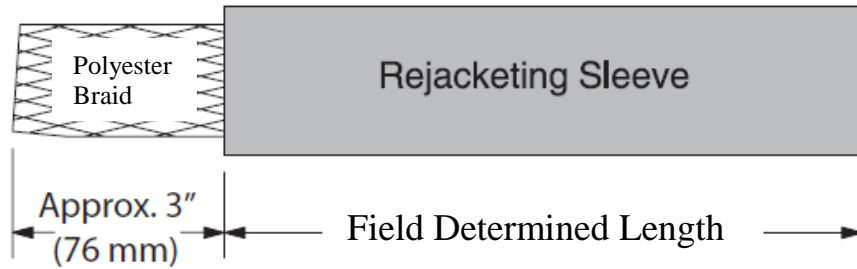

Not for specifications. Values are typical, not to be considered minimum or maximum. Properties measured at room temperature 73°F (23°C) unless otherwise stated.

-Silicone Rubber Rejacketing Sleeve-

Physical Property (Test Method)	Typical Value US units (metric)
Color	Dark Gray
Wall Thickness (3M Test Method)	0.065" (1,65 mm)
Tear Strength (ASTM D-624 B)	180 PSI (32 kg/cm)
Ultimate Tensile Strength (ASTM D-412)	1058 PSI (7,3 mPa)
Modulus @ 50% Stretch (ASTM D-412)	32 PSI (0,22 mPa)
Modulus @ 100% Stretch (ASTM D-412)	45 PSI (0,31 mPa)
Ultimate Elongation (ASTM D-412)	910%
Temperature Rating (3M Test Method)	356°F (180°C) Class H

Electrical Property (Test Method)	Typical Value US units (metric)
Voltage Class Rating (3M Test Method)	Up to 35 kV (Termination based)
Dielectric Strength @ 0.065" (3M Test Method)	428 V/mil (17 kV/mm)
Track Resistance @ 2.5 kV (ASTM D-2303/IEC 587)	6 hours

Rejacketing Sleeve Selection Guide — Based on Metallic Shield Diameter Range and Cable Conductor Size

Product Number	Metallic Shield Diameter Range	3.3 kV (mm ²)	3.3 kV (mm ²)	5.0 kV (AWG)	6.6 kV (mm ²)	6.6 kV (mm ²)	8.0 kV (AWG)
		IEC	JIS	AEIC	IEC	JIS	AEIC
RJS-1	0.43 - 0.60" (10,9 - 15,2 mm)	16 - 35	8 - 22	8 - 2	16 - 25	8 - 10	6 - 4
RJS-2	0.60 - 0.80" (15,2 - 20,3 mm)	50 - 95	38 - 60	1 - 3/0	35 - 70	14 - 38	2 - 2/0
RJS-3	0.80 - 1.02" (20,3 - 25,9 mm)	120 - 185	100 - 150	4/0 - 400	95 - 150	60 - 100	3/0 - 350
RJS-4	1.02 - 1.28" (25,9 - 32,5 mm)	240 - 300	200 - 250	500 - 750	185 - 300	150 - 250	400 - 600
RJS-5	1.28 - 1.62" (32,5 - 41,1 mm)	-	300 - 325	800 - 1000	-	300 - 325	750 - 1000
RJS-6	1.62 - 1.91" (41,1 - 48,5 mm)	-	-	-	-	-	-

IEC = International Electrotechnical Commission
 JIS = Japanese Industrial Standard
 AEIC = Association of Edison Illuminating Companies

3M™ RJS Series Rejacketing Sleeves

Rejacketing Sleeve Selection Guide — Based on Metallic Shield Diameter Range and Cable Conductor Size

Product Number	Metallic Shield Diameter Range	10 kV (mm ²)	15 kV (AWG)	20 kV (mm ²)	25 kV (AWG)	30 kV (mm ²)	35 kV (AWG)
		IEC	AEIC	IEC	AEIC	IEC	AEIC
RJS-1	0.43 - 0.60" (10,9 - 15,2 mm)	-	-	-	-	-	-
RJS-2	0.60 - 0.80" (15,2 - 20,3 mm)	10 - 50	2 - 1	-	-	-	-
RJS-3	0.80 - 1.02" (20,3 - 25,9 mm)	70 - 150	1/0 - 4/0	25 - 70	2 - 1/0	-	-
RJS-4	1.02 - 1.28" (25,9 - 32,5 mm)	185 - 300	250 - 450	95 - 185	2/0 - 250	35 - 70	1/0 - 3/0
RJS-5	1.28 - 1.62" (32,5 - 41,1 mm)	-	500 - 750	240 - 300	300 - 500	95 - 240	4/0 - 500
RJS-6	1.62 - 1.91" (41,1 - 48,5 mm)				750	240 - 325	500 - 750

IEC = International Electrotechnical Commission
AEIC = Association of Edison Illuminating Companies

Product Specification

RJS Series Rejacketing Sleeve assemblies can be used on cables with a continuous operating temperature of 221°F (105°C) and an emergency overload temperature of 284°F (140°C). When used in combination with 3M™ Cold Shrink Terminations, RJS Series Rejacketing Sleeves meet, or exceed, the current rating of the cable on which they have been applied.

According to IEEE Standard 48 definition, a 3/C Class 1 Termination designation is achieved by combining three easy-to-use accessories: (a) 3M™ Cold Shrink Breakout Boot, (b) 3M™ RJS Series Rejacketing Sleeve assemblies and (c) 3M™ Cold Shrink Silicone Rubber Termination Assemblies.

Cable phase rejacketing insulators are components of 3/C cable terminations and as such, must conform to all internationally recognized termination performance standards; specifically to VDE 0278 and the Class 1 designation of IEEE Standard 48. Each phase (core) insulator shall be made of track resistant silicone rubber, dark gray in color and, shall install by hand as a one-piece, continuous length assembly. Application shall require no flame, heat source or specialized tools. Rejacketing insulators must be length adjustable to conform with all field determined equipment installation requirements.

3M™ RJS Series Rejacketing Sleeves

Engineering/ Architectural Specification

Insulate and protect shielded phase (core) legs for all 3/C, 3.3 kV through 35 kV Class, cable in accordance with the instructions provided in 3M™ RJS Series Rejacketing Sleeve product kits.

Performance Tests

Critical performance characteristics for 3/C cable termination phase insulators include resistance to damage from impulse flashover and from tracking during long term exposure to severe environmental conditions.

Impulse Flashover

3M Test Method — Maximum Impulse

The purpose of this test method is to establish both the maximum impulse withstand level and the 100% impulse flashover level (on both positive and negative polarity) for high voltage terminations.

The test consists of a stepped sequence of surges (3 surges per step) at increasing voltage levels. For terminations this sequence continues until three surges at a given voltage result in three flashovers. There are indications that this stepped method artificially drives the flashover level higher than the termination would normally withstand on a one shot application of the surge.

A 1.2 x 50 microsecond voltage wave is applied to the termination as per IEEE Standard 48. Additional test standard references and procedures include those of IEEE Standard 48, *IEEE Standard Test Procedures and Requirements for Alternating Current Cable Terminations 2.5 kV through 765 kV* and IEEE Standard 82, *IEEE Standard Test Procedure for Impulse Voltage Tests on Insulated Conductors*.

15 kV Class 3/C termination samples were built using 3M™ 3/C Phase Rejacketing System RJS Series sleeve phase insulators and 3M™ Cold Shrink QT-III Silicone Rubber Terminations. Two configurations were included in this evaluation; those with an exposed grounding ring at the termination base (control) and those without. All specimens exceeded the IEEE Standard 48 BIL requirement by 50% during this test. Increasing the impulse voltage to termination breakdown level resulted in no damage to 3M™ RJS Series Rejacketing Sleeve components.

Alternating Current (AC) Flashover Test

3M Test Method — AC Step Test

The purpose of this test method is to establish the highest AC voltage that a termination can withstand and is used to determine termination performance relative to the requirements outlined in IEEE Standard 48.

Terminations are exposed to a stepped AC voltage rise to failure or flashover. The voltage magnitude required to arc across the termination surface in air (from terminal lug to ground point) is determined.

3/C 15 kV Class Termination samples tested with and without exposed termination body grounding rings achieved test levels associated with 25 kV Class products during this evaluation. 3M™ 3/C Phase Rejacketing System RJS Series sleeve, were not damaged at the flashover level.

3M™ RJS Series Rejacketing Sleeves

**“Continued”
Engineering/
Architectural
Specification**

Contamination Chamber

3M Test Method — ASTM 2132 Contaminant

Terminations are coated with slurry consisting of flint, clay, paper pulp, salt and water, and allowed to dry. They are then placed in the test chamber where they are energized at 1 1/2 times rated voltage and exposed to a continuous water mist spray from a rotating nozzle. Individual terminations are recoated every 300 hours.

Because of the salt content and other solid particulates, this procedure is thought to be representative of exposures at industrial/sea coast locations.

To determine the tracking performance capability of 3M™ 3/C Phase Rejacketing System RJS Series sleeve assemblies, 15 kV Class 3/C termination specimens were built with grounding rings located over the rejacketing sleeves; eight and sixteen inches below the termination bodies respectively.

Specimens exceeded 2500 hours under these test conditions. This is as long or longer, than 1/C conventionally grounded terminations samples will endure. There were no signs of rejacketing sleeve material degradation or tracking at the conclusion of the test.

3M™ RJS Series Rejacketing Sleeves

Environmental Performance

Hydrophobicity

When airborne contaminants are deposited on a termination surface, destructive leakage currents can initiate when the surface becomes wet. Fog and drizzle are normally considered to be worse than rain as these two forms of precipitation can combine with accumulated surface contaminants to reduce surface resistivity and promote leakage current formation. Rain tends to wash the pollutants off the termination surface.

Silicone RJS Rejacketing Sleeves are hydrophobic, tending to reject moisture accumulation and thereby, reducing the probability for discharge-initiated material erosion and tracking.

On occasion, severe environmental conditions that are sustained for long time periods can cause any polymeric surface to lose its hydrophobicity. Because of this, EPDM polymers and others tend to lose their hydrophobic nature over time. Porcelain surfaces become increasingly hydrophilic with time which can result in premature failure or flashover. Silicone surfaces can regenerate their hydrophobic character. This unique ability is a major factor for ensuring a long service life.

Ozone, Heat and UV Resistance

One of the most outstanding physical characteristics of silicone rubber is its retention of desirable properties over the very wide temperature range of -150°F (-100°C) to 600°F (315°C). While there are applications that take advantage of these temperature extremes, a more attractive feature might be that of its extremely long life expectancy at moderate operating temperatures.

The silicone polymer molecular backbone, silicon-oxygen linkage, provides the same strong $-\text{Si}-\text{O}-\text{Si}-$ type bond occurring in quartz, sand and glass which accounts for the outstanding temperature properties of silicones and their resistance to oxidation by ozone, corona and weathering. Polymer chains from organic rubber materials often have double carbon bond molecular backbones which are quickly cleaved by ozone, ultraviolet light, heat or other influences found in the operating environment.

3M™ RJS Series Rejacketing Sleeves

Solvent Resistance

“Continued” Environmental Performance

Solvent resistance testing for RJS Series Rejacketing Sleeve material was done by immersing pieces of the extruded tubing in some of the most common solvents (i.e. heptane acetone, hexane, toluene, MEK, THF, ethanol and 3M Cable Cleaning Fluid CC Series). Immersion time was at least 96 hours at room temperature.

Visual and tactile inspection of the samples after immersion revealed no dissolution or disintegration in any of the cases. That is, the material does not lose its integrity in the presence of the reference solvents. The table below summarizes these observations.

No chemical degradation (breaking of polymer chains) appears to occur upon exposure. The samples basically recover their initial physical strength upon evaporation of the solvent.

Solvent Type	Degree of Swelling (Approximate)	Physical Resistance (Apparent Strength)
3M™ Cable Cleaner CC Series	47%	Good (6)
Heptane	65%	Good (6)
Acetone	00%	No Effect (10)
Ethanol	00%	No Effect (10)
Hexane	63%	Fair (5)
MEK	23%	Excellent (8 - 9)
THF	70%	Fair (4)
Toluene	70%	Fair (5)
The number in parenthesis indicates the perceived strength on a 1 to 10 scale; right after immersion. 3M CC Series Cable Cleaner contains Petroleum Distillate: d-limonene		

3M™ RJS Series Rejacketing Sleeves

CAUTION

Working around energized high-voltage systems may cause serious injury or death. Installation should be performed by personnel familiar with good safety practice in handling high-voltage electrical equipment. De-energize and ground all electrical systems before installing product.

Installation Techniques

Detailed instructions for using 3M™ RJS Series Rejacketing Sleeve assemblies are included in each Three-Conductor 3M™ Cold Shrink QT-III Silicone Rubber Termination Kit and separate RJS Series Rejacketing Sleeve assembly kits to provide the installer with all of the information required to properly install the appropriately sized 3M™ RJS Series Rejacketing Sleeve Series assembly .

A brief summary of the installation steps for copper tape shielded cable is outlined as follows:

1. Cable jacket removal length and termination dimensional allowances are field determined according to specific equipment needs and user preferences. Phase rejacketing length is determined by voltage class based phase separation and mounting requirements.
2. Determine required length of cable shielding to be rejacketed ① (Figure 1–Typical).

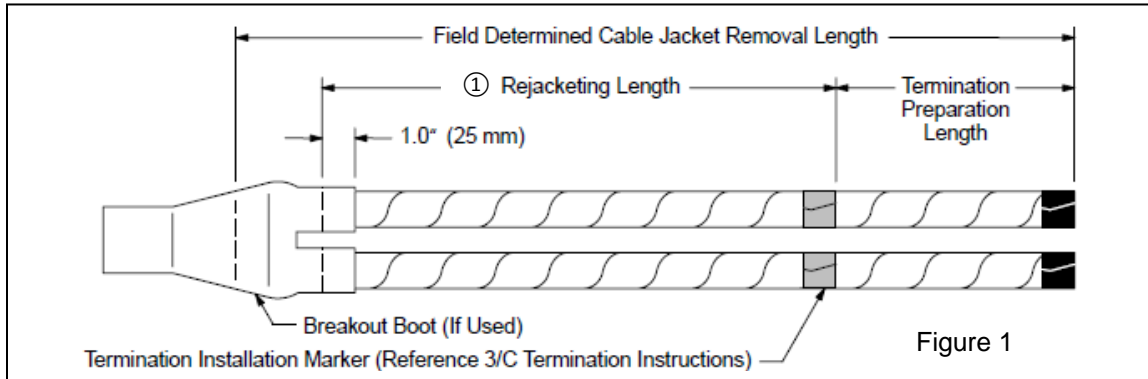

3. Using scissors or sharp knife, cut sleeve/braid assemblies to desired length ② - (Figure 2).

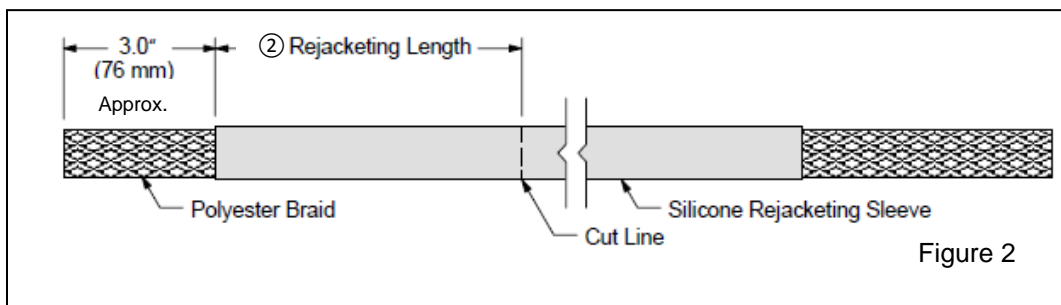

3M™ RJS Series Rejacketing Sleeves

4. Install rejacketing sleeve assemblies (Figure 3).
 - a. Open polyester braid end and push assembly into place ③ (Figure 3).
 - b. Push assembly to desired final position ④ (Figure 3), then fold silicone sleeve back on itself for 1.0" (25 mm).
 - c. Trim off exposed polyester braid material ④ (Figure 3).
 - d. Push sleeve assembly into final position and flip silicone sleeve into place ⑤ (Figure 3).

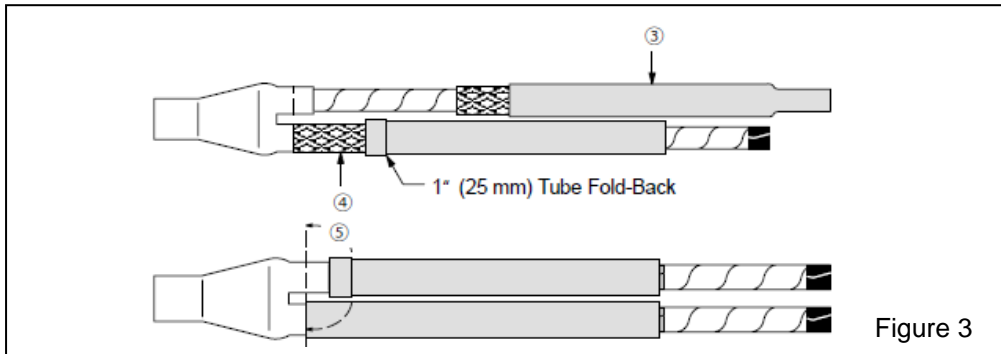

Figure 3

Maintenance 3M™ RJS Series Rejacketing Sleeve assemblies are not harmed by field surface cleaning. It should be noted however, that only extreme areas of environmental contamination should require this kind of attention. It is good practice to incorporate a general inspection/cleaning of the RJS Series sleeves during normal scheduled or maintenance inspections. Once the area has been de-energized, the RJS sleeves can be inspected, and if need be, cleaned. Some recommendations for surface cleaning 3M™ RJS Series Rejacketing Sleeve Series assemblies are as follows:

- Use a can of compressed 'air' in order to blast off dust and miscellaneous airborne contaminants on the surface of the RJS Series sleeve assembly. If needed, wipe the surface of the RJS Series sleeve assembly with a solvent, such as 3M™ Cable Cleaning Solvent (CC-Series), and allow it to dry before re-energizing the installation.
 - Mix a mild soap and water solution (deionized water is recommended, if available) in a hand sprayer, or spray bottle, and spray down the surface of the RJS Series sleeve assembly. Wipe dry, or allow to air dry, before re-energizing.
 - Do not abrade the surface of the RJS Series sleeve assembly in any way. Do not use high pressure cleaning (this can tear, or split, the RJS Series sleeve assemblies), high pressure water with corn cobs, sandpaper or other abrasive products. This will damage the RJS Series sleeve assembly surface and reduce tracking and arcing resistance.
-

3M™ RJS Series Rejacketing Sleeves

Shelf-Life and Storage

While 3M™ RJS Series Rejacketing Sleeve assemblies are not expected to deteriorate during extended storage periods, a 5 year shelf life limit is suggested. Maximum recommended storage temperature is 120°F (49°C). 3M RJS Series Rejacketing Sleeve assemblies are not affected by freezing. Standard stock rotation practice is recommended.

Availability

Please contact your local distributor; available from 3M.com/electrical [Where to Buy] or call 1.800.245.3573

3M is a trademark of 3M Company.

Important Notice

All statements, technical information, and recommendations related to 3M's products are based on information believed to be reliable, but the accuracy or completeness is not guaranteed. Before using this product, you must evaluate it and determine if it is suitable for your intended application. You assume all risks and liability associated with such use. Any statements related to the product, which are not contained in 3M's current publications, or any contrary statements contained on your purchase order, shall have no force or effect unless expressly agreed upon, in writing, by an authorized officer of 3M.

Warranty; Limited Remedy; Limited Liability

This product will be free from defects in material and manufacture at the time of purchase. **3M MAKES NO OTHER WARRANTIES INCLUDING, BUT NOT LIMITED TO, ANY IMPLIED WARRANTY OF MERCHANTABILITY OR FITNESS FOR A PARTICULAR PURPOSE.** If this product is defective within the warranty period stated above, your exclusive remedy shall be, at 3M's option, to replace or repair the 3M product or refund the purchase price of the 3M product. **Except where prohibited by law, 3M will not be liable for any indirect, special, incidental or consequential loss or damage arising from this 3M product, regardless of the legal theory asserted.**



Electrical Markets Division

6801 River Place Blvd.
Austin, TX 78726-9000
800.245.3573
FAX: 800.245.0329
www.3M.com/electrical

Please recycle
© 3M 2014 All rights reserved
78-8111-0894-9 Rev B

Компания «Life Electronics» занимается поставками электронных компонентов импортного и отечественного производства от производителей и со складов крупных дистрибьюторов Европы, Америки и Азии.

С конца 2013 года компания активно расширяет линейку поставок компонентов по направлению коаксиальный кабель, кварцевые генераторы и конденсаторы (керамические, пленочные, электролитические), за счёт заключения дистрибьюторских договоров

Мы предлагаем:

- Конкурентоспособные цены и скидки постоянным клиентам.
- Специальные условия для постоянных клиентов.
- Подбор аналогов.
- Поставку компонентов в любых объемах, удовлетворяющих вашим потребностям.
- Приемлемые сроки поставки, возможна ускоренная поставка.
- Доставку товара в любую точку России и стран СНГ.
- Комплексную поставку.
- Работу по проектам и поставку образцов.
- Формирование склада под заказчика.
- Сертификаты соответствия на поставляемую продукцию (по желанию клиента).
- Тестирование поставляемой продукции.
- Поставку компонентов, требующих военную и космическую приемку.
- Входной контроль качества.
- Наличие сертификата ISO.

В составе нашей компании организован Конструкторский отдел, призванный помогать разработчикам, и инженерам.

Конструкторский отдел помогает осуществить:

- Регистрацию проекта у производителя компонентов.
- Техническую поддержку проекта.
- Защиту от снятия компонента с производства.
- Оценку стоимости проекта по компонентам.
- Изготовление тестовой платы монтаж и пусконаладочные работы.



Тел: +7 (812) 336 43 04 (многоканальный)

Email: org@lifeelectronics.ru