

SUMMARY

High performance 32-bit/40-bit floating-point processor optimized for high performance audio processing
Single-instruction, multiple-data (SIMD) computational architecture

5 Mbits of on-chip RAM, 4 Mbits of on-chip ROM

Up to 450 MHz operating frequency

Qualified for automotive applications, see [Automotive Products on Page 70](#)

Code compatible with all other members of the SHARC family

The ADSP-21469 processor is available with unique audio-centric peripherals such as the digital applications interface, DTCP (digital transmission content protection protocol), serial ports, precision clock generators, S/PDIF transceiver, asynchronous sample rate converters, input data port, and more.

For complete ordering information, see [Ordering Guide on Page 70](#)

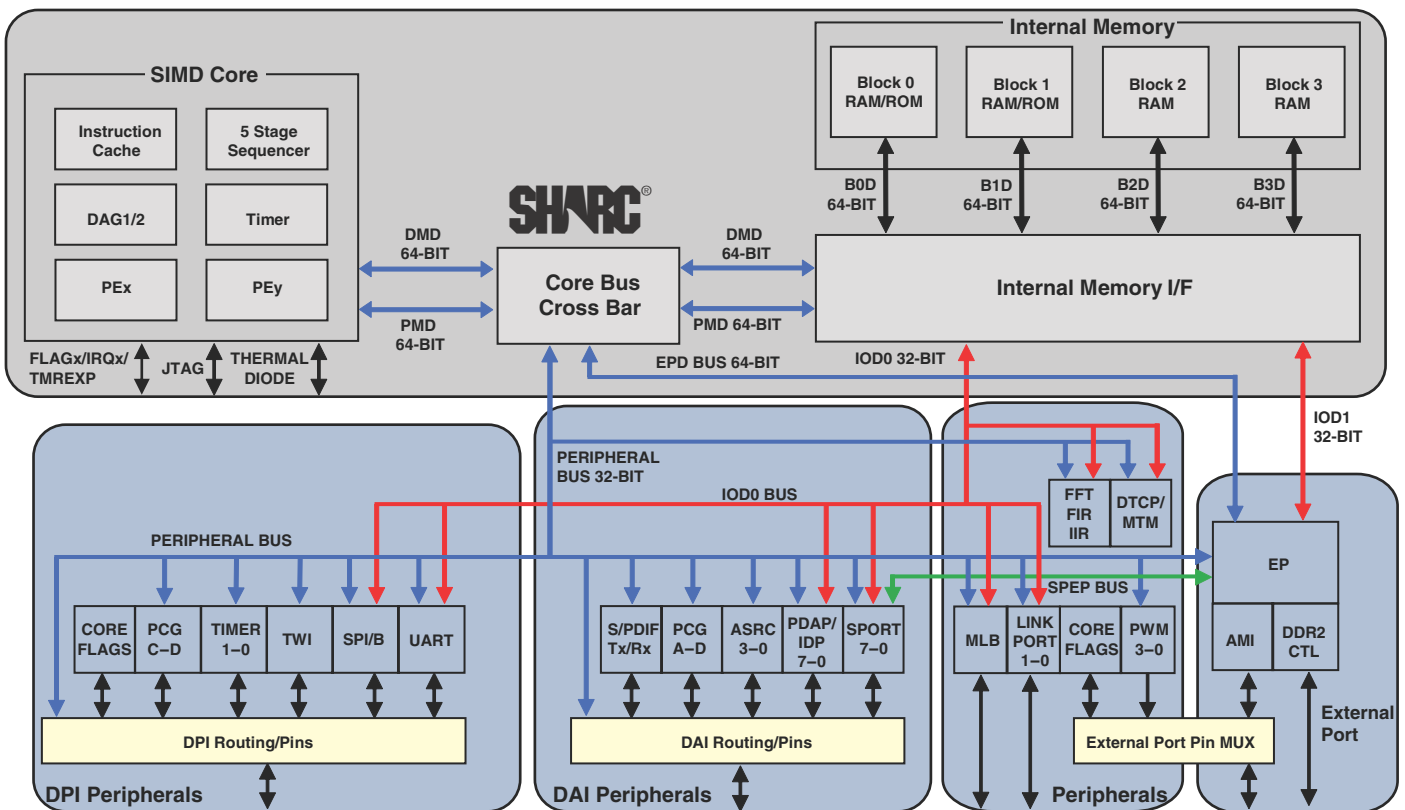

Figure 1. Functional Block Diagram

SHARC and the SHARC logo are registered trademarks of Analog Devices, Inc.

Rev. 0

Information furnished by Analog Devices is believed to be accurate and reliable. However, no responsibility is assumed by Analog Devices for its use, nor for any infringements of patents or other rights of third parties that may result from its use. Specifications subject to change without notice. No license is granted by implication or otherwise under any patent or patent rights of Analog Devices. Trademarks and registered trademarks are the property of their respective companies.

TABLE OF CONTENTS

Summary	1	Absolute Maximum Ratings	20
Revision History	2	ESD Sensitivity	20
General Description	3	Package Information	20
Family Core Architecture	4	Timing Specifications	21
Family Peripheral Architecture	7	Test Conditions	58
System Design	10	Output Drive Currents	58
Development Tools	11	Capacitive Loading	59
Additional Information	11	Thermal Characteristics	61
Related Signal Chains	11	CSP_BGA Ball Assignment—Automotive Models	63
Pin Function Descriptions	12	CSP_BGA Ball Assignment—Standard Models	66
Unused DDR2 Pins	12	Outline Dimensions	69
Specifications	17	Surface-Mount Design	69
Operating Conditions	17	Automotive Products	70
Electrical Characteristics	18	Ordering Guide	70

REVISION HISTORY

6/10—Revision 0: Initial Version

GENERAL DESCRIPTION

The ADSP-21469 SHARC[®] processor is a member of the SIMD SHARC family of DSPs that feature Analog Devices' Super Harvard Architecture. The processor is source code compatible with the ADSP-2126x, ADSP-2136x, ADSP-2137x, and ADSP-2116x DSPs, as well as with first generation ADSP-2106x SHARC processors in SISD (single-instruction, single-data) mode. The processor is a 32-bit/40-bit floating point processor optimized for high performance audio applications with its large on-chip SRAM, multiple internal buses to eliminate I/O bottlenecks, and an innovative digital applications interface (DAI).

Table 1 shows performance benchmarks for the ADSP-21469 processor, and Table 2 shows the product's features.

Table 1. Processor Benchmarks

Benchmark Algorithm	Speed (at 450 MHz)
1024 Point Complex FFT (Radix 4, with Reversal)	20.44 μ s
FIR Filter (Per Tap) ¹	1.11 ns
IIR Filter (Per Biquad) ¹	4.43 ns
Matrix Multiply (Pipelined)	
[3 × 3] × [3 × 1]	10.0 ns
[4 × 4] × [4 × 1]	17.78 ns
Divide (y/x)	6.67 ns
Inverse Square Root	10.0 ns

¹ Assumes two files in multichannel SIMD mode

Table 2. SHARC Family Features

Feature	ADSP-21469
Maximum Frequency	450 MHz
RAM	5M Bits
ROM	N/A
Audio Decoders in ROM ¹	No
DTCP Hardware Accelerator ²	No
Pulse-Width Modulation	Yes
S/PDIF	Yes
DDR2 Memory Interface	Yes
DDR2 Memory Bus Width	16 Bits
Direct DMA from SPORTs to External Memory	Yes
FIR, IIR, FFT Accelerator	Yes
MLB Interface	Automotive Models Only
IDP	Yes
Serial Ports	8
DAI (SRU)/DPI (SRU2)	20/14 pins

Table 2. SHARC Family Features (Continued)

Feature	ADSP-21469
UART	1
Link Ports	2
AMI Interface with 8-bit Support	Yes
SPI	2
TWI	Yes
SRC Performance	-128 dB
Package	324-ball CSP_BGA

¹ Audio decoding algorithms include PCM, Dolby Digital EX, Dolby Pro Logic IIx, DTS 96/24, Neo:6, DTS ES, MPEG-2 AAC, MP3, and functions like bass management, delay, speaker equalization, graphic equalization, and more. Decoder/postprocessor algorithm combination support varies depending upon the chip version and the system configurations. Please visit www.analog.com for complete product information and availability.

² These products contain the Digital Transmission Content Protection protocol, a proprietary security protocol. Contact your Analog Devices sales office for more information.

Figure 1 on Page 1 shows the two clock domains that make up the ADSP-21469 processors. The core clock domain contains the following features:

- Two processing elements (PE_x, PE_y), each of which comprises an ALU, multiplier, shifter, and data register file
- Data address generators (DAG1, DAG2)
- Program sequencer with instruction cache
- One periodic interval timer with pinout
- PM and DM buses capable of supporting 2 × 64-bit data transfers between memory and the core at every core processor cycle
- On-chip SRAM (5M bit)
- On-chip mask-programmable ROM (4M bit)
- JTAG test access port for emulation and boundary scan. The JTAG provides software debug through user breakpoints which allows flexible exception handling.

Figure 1 on Page 1 also shows the peripheral clock domain (also known as the I/O processor) which contains the following features:

- IOD0 (peripheral DMA) and IOD1 (external port DMA) buses for 32-bit data transfers
- Peripheral and external port buses for core connection
- External port with an AMI and DDR2 controller
- 4 units for PWM control
- 1 MTM unit for internal-to-internal memory transfers

ADSP-21469

- Digital applications interface that includes four precision clock generators (PCG), an input data port (IDP) for serial and parallel interconnect, an S/PDIF receiver/transmitter, four asynchronous sample rate converters, eight serial ports, a flexible signal routing unit (DAI SRU).
- Digital peripheral interface that includes two timers, a 2-wire interface, one UART, two serial peripheral interfaces (SPI), 2 precision clock generators (PCG) and a flexible signal routing unit (DPI SRU).

As shown in [Figure 1 on Page 1](#), the processor uses two computational units to deliver a significant performance increase over the previous SHARC processors on a range of DSP algorithms. With its SIMD computational hardware, the processors can perform 2.7 GFLOPS running at 450 MHz and 2.4 GFLOPS running at 400 MHz.

FAMILY CORE ARCHITECTURE

The ADSP-21469 is code compatible at the assembly level with the ADSP-2137x, ADSP-2136x, ADSP-2126x, ADSP-21160, and ADSP-21161, and with the first generation ADSP-2106x SHARC processors. The ADSP-21469 shares architectural features with the ADSP-2126x, ADSP-2136x, ADSP-2137x, and ADSP-2116x SIMD SHARC processors, as shown in [Figure 2](#) and detailed in the following sections.

SIMD Computational Engine

The ADSP-21469 contains two computational processing elements that operate as a single-instruction, multiple-data (SIMD) engine. The processing elements are referred to as PEX and PEY and each contains an ALU, multiplier, shifter, and register file. PEX is always active, and PEY may be enabled by setting the PEYEN mode bit in the MODE1 register. When this mode is enabled, the same instruction is executed in both processing elements, but each processing element operates on different data. This architecture is efficient at executing math intensive DSP algorithms.

Entering SIMD mode also has an effect on the way data is transferred between memory and the processing elements. When in SIMD mode, twice the data bandwidth is required to sustain computational operation in the processing elements. Because of this requirement, entering SIMD mode also doubles the bandwidth between memory and the processing elements. When using the DAGs to transfer data in SIMD mode, two data values are transferred with each access of memory or the register file.

Independent, Parallel Computation Units

Within each processing element is a set of computational units. The computational units consist of an arithmetic/logic unit (ALU), multiplier, and shifter. These units perform all operations in a single cycle. The three units within each processing element are arranged in parallel, maximizing computational throughput. Single multifunction instructions execute parallel ALU and multiplier operations. In SIMD mode, the parallel ALU and multiplier operations occur in both processing elements. These computation units support IEEE 32-bit single-precision floating-point, 40-bit extended precision floating-point, and 32-bit fixed-point data formats.

Timer

A core timer that can generate periodic software Interrupts. The core timer can be configured to use FLAG3 as a timer expired signal.

Data Register File

A general-purpose data register file is contained in each processing element. The register files transfer data between the computation units and the data buses, and store intermediate results. These 10-port, 32-register (16 primary, 16 secondary) register files, combined with the processor's enhanced Harvard architecture, allow unconstrained data flow between computation units and internal memory. The registers in PEX are referred to as R0-R15 and in PEY as S0-S15.

Context Switch

Many of the processor's registers have secondary registers that can be activated during interrupt servicing for a fast context switch. The data registers in the register file, the DAG registers, and the multiplier result registers all have secondary registers. The primary registers are active at reset, while the secondary registers are activated by control bits in a mode control register.

Universal Registers

These registers can be used for general-purpose tasks. The USTAT (4) registers allow easy bit manipulations (Set, Clear, Toggle, Test, XOR) for all system registers (control/status) of the core.

The data bus exchange register (PX) permits data to be passed between the 64-bit PM data bus and the 64-bit DM data bus, or between the 40-bit register file and the PM/DM data buses. These registers contain hardware to handle the data width difference.

Single-Cycle Fetch of Instruction and Four Operands

The processors feature an enhanced Harvard Architecture in which the data memory (DM) bus transfers data and the program memory (PM) bus transfers both instructions and data (see [Figure 2](#)). With its separate program and data memory buses and on-chip instruction cache, the processor can simultaneously fetch four operands (two over each data bus) and one instruction (from the cache), all in a single cycle.

Instruction Cache

The processors contain an on-chip instruction cache that enables three-bus operation for fetching an instruction and four data values. The cache is selective—only the instructions whose fetches conflict with PM bus data accesses are cached. This cache allows full speed execution of core, looped operations such as digital filter multiply-accumulates, and FFT butterfly processing.

Data Address Generators With Zero-Overhead Hardware Circular Buffer Support

The two data address generators (DAGs) are used for indirect addressing and implementing circular data buffers in hardware. Circular buffers allow efficient programming of delay lines and

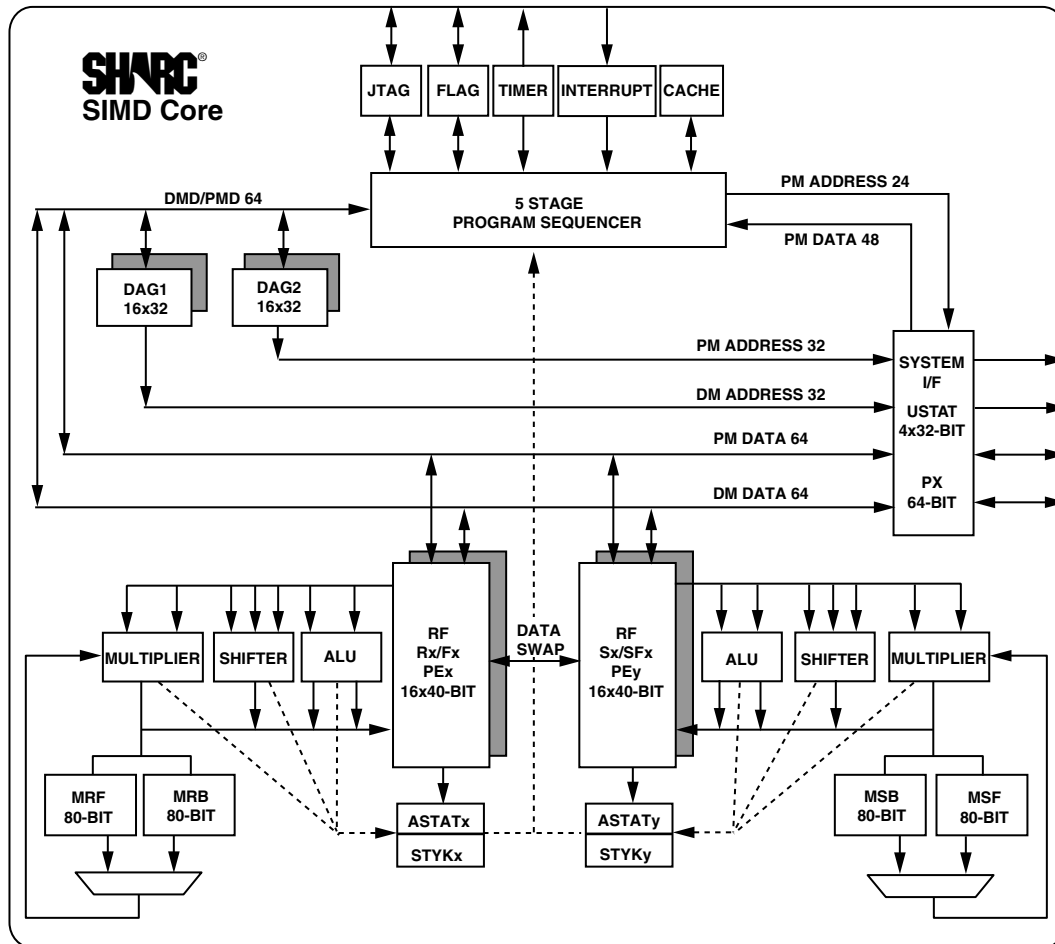

Figure 2. SHARC Core Block Diagram

other data structures required in digital signal processing, and are commonly used in digital filters and Fourier transforms. The two DAGs of the processors contain sufficient registers to allow the creation of up to 32 circular buffers (16 primary register sets, 16 secondary). The DAGs automatically handle address pointer wraparound, reduce overhead, increase performance, and simplify implementation. Circular buffers can start and end at any memory location.

Flexible Instruction Set

The 48-bit instruction word accommodates a variety of parallel operations for concise programming. For example, the ADSP-21469 can conditionally execute a multiply, an add, and a subtract in both processing elements while branching and fetching up to four 32-bit values from memory—all in a single instruction.

Variable Instruction Set Architecture (VISA)

In addition to supporting the standard 48-bit instructions from previous SHARC processors, the ADSP-21469 supports new instructions of 16 and 32 bits. This feature, called Variable

Instruction Set Architecture (VISA), drops redundant/unused bits within the 48-bit instruction to create more efficient and compact code. The program sequencer supports fetching these 16-bit and 32-bit instructions from both internal and external DDR2 memory. Source modules need to be built using the VISA option in order to allow code generation tools to create these more efficient opcodes.

On-Chip Memory

The processors contain 5 Mbits of internal RAM. Each block can be configured for different combinations of code and data storage (see Table 4). Each memory block supports single-cycle, independent accesses by the core processor and I/O processor. The ADSP-21469 memory architecture, in combination with its separate on-chip buses, allows two data transfers from the core and one from the I/O processor in a single cycle.

The processor's SRAM can be configured as a maximum of 160k words of 32-bit data, 320k words of 16-bit data, 106.7k words of 48-bit instructions (or 40-bit data), or combinations of different word sizes up to 5 Mbits. All of the memory can be accessed as 16-bit, 32-bit, 48-bit, or 64-bit words. A 16-bit

ADSP-21469

floating-point storage format is supported that effectively doubles the amount of data that may be stored on-chip. Conversion between the 32-bit floating-point and 16-bit floating-point formats is performed in a single instruction. While each memory block can store combinations of code and data, accesses are most efficient when one block stores data using the DM bus for transfers, and the other block stores instructions and data using the PM bus for transfers.

Using the DM bus and PM buses, with one bus dedicated to a memory block, assures single-cycle execution with two data transfers. In this case, the instruction must be available in the cache.

The memory map in [Table 3](#) displays the internal memory address space of the ADSP-21469 processor.

The 48-bit space section describes what this address range looks like to an instruction that retrieves 48-bit memory. The 32-bit section describes what this address range looks like to an instruction that retrieves 32-bit memory.

On-Chip Memory Bandwidth

The internal memory architecture allows programs to have four accesses at the same time to any of the four blocks (assuming there are no block conflicts). The total bandwidth is realized using the DMD and PMD buses (2 × 64-bits, CCLK speed) and the IOD0/1 buses (2 × 32-bit, PCLK speed).

Non-Secured ROM

For non-secured ROM, booting modes are selected using the BOOTCFG pins as shown in [Table 8 on Page 10](#). In this mode, emulation is always enabled, and the IVT is placed on the internal RAM except for the case where BOOTCFGx = 011.

ROM Based Security

The ADSP-21469 has a ROM security feature that provides hardware support for securing user software code by preventing unauthorized reading from the internal code when enabled. When using this feature, the processor does not boot-load any external code, executing exclusively from internal ROM. Additionally, the processor is not freely accessible via the JTAG port. Instead, a unique 64-bit key, which must be scanned in through the JTAG or Test Access Port will be assigned to each customer. The device ignores a wrong key. Emulation features are available after the correct key is scanned.

Digital Transmission Content Protection

The DTCP specification defines a cryptographic protocol for protecting audio entertainment content from illegal copying, intercepting, and tampering as it traverses high performance digital buses, such as the IEEE 1394 standard. Only legitimate entertainment content delivered to a source device via another approved copy protection system (such as the DVD content scrambling system) is protected by this copy protection system.

Table 3. ADSP-21469 Internal Memory Space

IOP Registers 0x0000 0000–0x0003 FFFF			
Long Word (64 bits)	Extended Precision Normal or Instruction Word (48 bits)	Normal Word (32 bits)	Short Word (16 bits)
BLOCK 0 RAM 0x0004 9000–0x0004 EFFF	BLOCK 0 RAM 0x0008 C000–0x0009 3FFF	BLOCK 0 RAM 0x0009 2000–0x0009 DFFF	BLOCK 0 RAM 0x0012 4000–0x0013 BFFF
Reserved 0x0004 F000–0x0005 8FFF	Reserved 0x0009 4000–0x0009 5554	Reserved 0x0009 E000–0x000B 1FFF	Reserved 0x0013 C000–0x0016 3FFF
BLOCK 1 RAM 0x0005 9000–0x0005 EFFF	BLOCK 1 RAM 0x000A C000–0x000B 3FFF	BLOCK 1 RAM 0x000B 2000–0x000B DFFF	BLOCK 1 RAM 0x0016 4000–0x0017 BFFF
Reserved 0x0005 F000–0x0005 FFFF	Reserved 0x000B 4000–0x000B 5554	Reserved 0x000B E000–0x000B FFFF	Reserved 0x0017 C000–0x0017 FFFF
BLOCK 2 RAM 0x0006 0000–0x0006 3FFF	BLOCK 2 RAM 0x000C 0000–0x000C 5554	BLOCK 2 RAM 0x000C 0000–0x000C 7FFF	BLOCK 2 RAM 0x0018 0000–0x0018 FFFF
Reserved 0x0006 4000–0x0006 FFFF	Reserved 0x000C 5555–0x000D 5554	Reserved 0x000C 8000–0x000D FFFF	Reserved 0x0019 0000–0x001B FFFF
BLOCK 3 RAM 0x0007 0000–0x0007 3FFF	BLOCK 3 RAM 0x000E 0000–0x000E 5554	BLOCK 3 RAM 0x000E 0000–0x000E 7FFF	BLOCK 3 RAM 0x001C 0000–0x001C FFFF
Reserved 0x0007 4000–0x0007 FFFF	Reserved 0x000E 5555–0x000F 5554	Reserved 0x000E 8000–0x000F FFFF	Reserved 0x001D 0000–0x001F FFFF

FAMILY PERIPHERAL ARCHITECTURE

The ADSP-21469 family contains a rich set of peripherals that support a wide variety of applications including high quality audio, medical imaging, communications, military, test equipment, 3D graphics, speech recognition, motor control, imaging, and other applications.

External Port

The external port interface supports access to the external memory through core and DMA accesses. The external memory address space is divided into four banks. Any bank can be programmed as either asynchronous or synchronous memory. The external ports are comprised of the following modules.

- An Asynchronous Memory Interface which communicates with SRAM, Flash, and other devices that meet the standard asynchronous SRAM access protocol. The AMI supports 2M words of external memory in bank 0 and 4M words of external memory in bank 1, bank 2, and bank 3.
- A DDR2 DRAM controller. External memory devices up to 2 Gbits in size can be supported.
- Arbitration Logic to coordinate core and DMA transfers between internal and external memory over the external port.

External Memory

The external port on the processor provides a high performance, glueless interface to a wide variety of industry-standard memory devices. The external port may be used to interface to synchronous and/or asynchronous memory devices through the use of its separate internal DDR2 memory controller. The 16-bit DDR2 DRAM controller connects to industry-standard synchronous DRAM devices, while the second 8-bit asynchronous memory controller is intended to interface to a variety of memory devices. Four memory select pins enable up to four separate devices to coexist, supporting any desired combination of synchronous and asynchronous device types. Non-DDR2 DRAM external memory address space is shown in [Table 4](#).

Table 4. External Memory for Non-DDR2 DRAM Addresses

Bank	Size in Words	Address Range
Bank 0	2M	0x0020 0000 – 0x003F FFFF
Bank 1	4M	0x0400 0000 – 0x043F FFFF
Bank 2	4M	0x0800 0000 – 0x083F FFFF
Bank 3	4M	0x0C00 0000 – 0x0C3F FFFF

SIMD Access to External Memory

The DDR2 controller on the ADSP-21469 processor supports SIMD access on the 64-bit EPD (external port data bus) which allows to access the complementary registers on the PEy unit in the normal word space (NW). This improves performance since there is no need to explicitly load the complimentary registers as in SISD mode.

VISA and ISA Access to External Memory

The DDR2 controller on the ADSP-21469 processor supports VISA code operation which reduces the memory load since the VISA instructions are compressed. Moreover, bus fetching is reduced because, in the best case, one 48-bit fetch contains three valid instructions. Code execution from the traditional ISA operation is also supported. Note that code execution is only supported from bank 0 regardless of VISA/ISA. [Table 5](#) shows the address ranges for instruction fetch in each mode.

Table 5. External Bank 0 Instruction Fetch

Access Type	Size in Words	Address Range
ISA (NW)	4M	0x0020 0000 – 0x005F FFFF
VISA (SW)	10M	0x0060 0000 – 0x00FF FFFF

DDR2 Support

The ADSP-21469 supports a 16-bit DDR2 interface operating at a maximum frequency of half the core clock. Execution from external memory is supported. External memory devices up to 2 Gbits in size can be supported.

DDR2 DRAM Controller

The DDR2 DRAM controller provides a 16-bit interface to up to four separate banks of industry-standard DDR2 DRAM devices. Fully compliant with the DDR2 DRAM standard, each bank can have its own memory select line (DDR2_CS3 – DDR2_CS0), and can be configured to contain between 32M bytes and 256M bytes of memory. DDR2 DRAM external memory address space is shown in [Table 6](#).

A set of programmable timing parameters is available to configure the DDR2 DRAM banks to support memory devices.

Table 6. External Memory for DDR2 DRAM Addresses

Bank	Size in Words	Address Range
Bank 0	62M	0x0020 0000 – 0x03FF FFFF
Bank 1	64M	0x0400 0000 – 0x07FF FFFF
Bank 2	64M	0x0800 0000 – 0x0BFF FFFF
Bank 3	64M	0x0C00 0000 – 0x0FFF FFFF

Note that the external memory bank addresses shown are for normal-word (32-bit) accesses. If 48-bit instructions, as well as 32-bit data, are both placed in the same external memory bank, care must be taken while mapping them to avoid overlap.

Asynchronous Memory Controller

The asynchronous memory controller provides a configurable interface for up to four separate banks of memory or I/O devices. Each bank can be independently programmed with different timing parameters, enabling connection to a wide variety

ADSP-21469

of memory devices including SRAM, Flash, and EPROM, as well as I/O devices that interface with standard memory control lines. Bank 0 occupies a 2M word window and banks 1, 2, and 3 occupy a 4M word window in the processor's address space but, if not fully populated, these windows are not made contiguous by the memory controller logic.

External Port Throughput

The throughput for the external port, based on a 400 MHz clock, is 66M bytes/s for the AMI and 800M bytes/s for DDR2.

Link Ports

Two 8-bit wide link ports can connect to the link ports of other DSPs or peripherals. Link ports are bidirectional ports having eight data lines, an acknowledge line, and a clock line. Link ports can operate at a maximum frequency of 166 MHz.

MediaLB

The ADSP-21469 automotive model has a MLB interface which allows the processor to function as a media local bus device. It includes support for both 3-pin and 5-pin media local bus protocols. It supports speeds up to 1024 FS (49.25 Mbits/sec, FS = 48.1 kHz) and up to 31 logical channels, with up to 124 bytes of data per media local bus frame.

The MLB interface supports MOST25 and MOST50 data rates. The isochronous mode of transfer is not supported.

Pulse-Width Modulation

The PWM module is a flexible, programmable, PWM waveform generator that can be programmed to generate the required switching patterns for various applications related to motor and engine control or audio power control. The PWM generator can generate either center-aligned or edge-aligned PWM waveforms. In addition, it can generate complementary signals on two outputs in paired mode or independent signals in non-paired mode (applicable to a single group of four PWM waveforms). The PWM generator is capable of operating in two distinct modes while generating center-aligned PWM waveforms: single update mode or double update mode.

The entire PWM module has four groups of four PWM outputs each. Therefore, this module generates 16 PWM outputs in total. Each PWM group produces two pairs of PWM signals on the four PWM outputs.

Digital Applications Interface (DAI)

The digital applications interface (DAI) provides the ability to connect various peripherals to any of the DAI pins (DAI_P20–1).

Programs make these connections using the signal routing unit (SRU), shown in [Figure 1 on Page 1](#).

The SRU is a matrix routing unit (or group of multiplexers) that enables the peripherals provided by the DAI to be interconnected under software control. This allows easy use of the DAI associated peripherals for a much wider variety of applications by using a larger set of algorithms than is possible with nonconfigurable signal paths.

The DAI includes the peripherals described in the following sections.

Serial Ports

The ADSP-21469 features eight synchronous serial ports that provide an inexpensive interface to a wide variety of digital and mixed-signal peripheral devices such as Analog Devices' AD183x family of audio codecs, ADCs, and DACs. The serial ports are made up of two data lines, a clock, and frame sync. The data lines can be programmed to either transmit or receive and each data line has a dedicated DMA channel.

Serial ports can support up to 16 transmit or 16 receive DMA channels of audio data when all eight SPORTs are enabled, or four full duplex TDM streams of 128 channels per frame.

The serial ports operate at a maximum data rate of $f_{PCLK}/4$. Serial port data can be automatically transferred to and from on-chip memory/external memory via dedicated DMA channels. Each of the serial ports can work in conjunction with another serial port to provide TDM support. One SPORT provides two transmit signals while the other SPORT provides the two receive signals. The frame sync and clock are shared.

Serial ports operate in five modes:

- Standard DSP serial mode
- Multichannel (TDM) mode
- I²S mode
- Packed I²S mode
- Left-justified mode

S/PDIF-Compatible Digital Audio Receiver/Transmitter

The S/PDIF receiver/transmitter has no separate DMA channels. It receives audio data in serial format and converts it into a biphase encoded signal. The serial data input to the receiver/transmitter can be formatted as left justified, I²S or right justified with word widths of 16, 18, 20, or 24 bits.

The serial data, clock, and frame sync inputs to the S/PDIF receiver/transmitter are routed through the signal routing unit (SRU). They can come from a variety of sources, such as the SPORTs, external pins, and the precision clock generators (PCGs), and are controlled by the SRU control registers.

Asynchronous Sample Rate Converter

The asynchronous sample rate converter (ASRC) contains four ASRC blocks, is the same core as that used in the AD1896 192 kHz stereo asynchronous sample rate converter, and provides up to 128 dB SNR. The ASRC block is used to perform synchronous or asynchronous sample rate conversion across independent stereo channels, without using internal processor resources. The four SRC blocks can also be configured to operate together to convert multichannel audio data without phase mismatches. Finally, the ASRC can be used to clean up audio data from jittery clock sources such as the S/PDIF receiver.

Input Data Port

The IDP provides up to eight serial input channels—each with its own clock, frame sync, and data inputs. The eight channels are automatically multiplexed into a single 32-bit by eight-deep FIFO. Data is always formatted as a 64-bit frame and divided into two 32-bit words. The serial protocol is designed to receive audio channels in I²S, left-justified sample pair, or right-justified mode. One frame sync cycle indicates one 64-bit left/right pair, but data is sent to the FIFO as 32-bit words (that is, one-half of a frame at a time). The processor supports 24- and 32-bit I²S, 24- and 32-bit left-justified, and 24-, 20-, 18- and 16-bit right-justified formats.

Precision Clock Generators

The precision clock generators (PCG) consist of four units—A, B, C, and D, each of which generates a pair of signals (clock and frame sync) derived from a clock input signal. The units are identical in functionality and operate independently of each other. The two signals generated by each unit are normally used as a serial bit clock/frame sync pair.

Digital Peripheral Interface (DPI)

The digital peripheral interface provides connections to two serial peripheral interface (SPI) ports, one universal asynchronous receiver-transmitter (UART), 12 flags, a 2-wire interface (TWI), and two general-purpose timers. The DPI includes the peripherals described in the following sections.

Serial Peripheral Interface

The ADSP-21469 SHARC processors contain two serial peripheral interface ports (SPI). The SPI is an industry-standard synchronous serial link, enabling the SPI-compatible port to communicate with other SPI compatible devices. The SPI consists of two data pins, one device select pin, and one clock pin. It is a full-duplex synchronous serial interface, supporting both master and slave modes. The SPI port can operate in a multi-master environment by interfacing with up to four other SPI-compatible devices, either acting as a master or slave device. The SPI-compatible peripheral implementation also features programmable baud rate, clock phase, and polarities. The SPI-compatible port uses open-drain drivers to support a multimas-ter configuration and to avoid data contention.

UART Port

The processors provide a full-duplex Universal Asynchronous Receiver/Transmitter (UART) port, which is fully compatible with PC-standard UARTs. The UART port provides a simplified UART interface to other peripherals or hosts, supporting full-duplex, DMA-supported, asynchronous transfers of serial data. The UART also has multiprocessor communication capability using 9-bit address detection. This allows it to be used in multidrop networks through the RS-485 data interface standard. The UART port also includes support for 5 to 8 data bits, 1 or 2 stop bits, and none, even, or odd parity. The UART port supports two modes of operation:

- PIO (programmed I/O) – The processor sends or receives data by writing or reading I/O-mapped UART registers. The data is double-buffered on both transmit and receive.

- DMA (direct memory access) – The DMA controller transfers both transmit and receive data. This reduces the number and frequency of interrupts required to transfer data to and from memory.

Timers

The ADSP-21469 has a total of three timers: a core timer that can generate periodic software interrupts and two general-purpose timers that can generate periodic interrupts and be independently set to operate in one of three modes:

- Pulse waveform generation mode
- Pulse width count/capture mode
- External event watchdog mode

The core timer can be configured to use FLAG3 as a timer expired signal, and each general-purpose timer has one bidirectional pin and four registers that implement its mode of operation. A single control and status register enables or disables both general-purpose timers independently.

2-Wire Interface Port (TWI)

The TWI is a bidirectional, 2-wire serial bus used to move 8-bit data while maintaining compliance with the I²C bus protocol. The TWI master incorporates the following features:

- 7-bit addressing
- Simultaneous master and slave operation on multiple device systems with support for multi master data arbitration
- Digital filtering and timed event processing
- 100 kbps and 400 kbps data rates
- Low interrupt rate

I/O Processor Features

Automotive versions of the ADSP-21469 I/O processor provide 67 channels of DMA, while standard versions provide 36 channels of DMA, as well as an extensive set of peripherals that are described in the following sections.

DMA Controller

The processor's on-chip DMA controller allows data transfers without processor intervention. The DMA controller operates independently and invisibly to the processor core, allowing DMA operations to occur while the core is simultaneously executing its program instructions. DMA transfers can occur between the ADSP-21469's internal memory and its serial ports, the SPI-compatible (serial peripheral interface) ports, the IDP (input data port), the parallel data acquisition port (PDAP), or the UART.

Up to 67 channels of DMA are available on the ADSP-21469 processors as shown in [Table 7](#). Programs can be downloaded to the ADSP-21469 using DMA transfers. Other DMA features include interrupt generation upon completion of DMA transfers, and DMA chaining for automatic linked DMA transfers.

ADSP-21469

Delay Line DMA

The ADSP-21469 processor provides delay line DMA functionality. This allows processor reads and writes to external delay line buffers (and hence to external memory) with limited core interaction.

Scatter/Gather DMA

The ADSP-21469 processor provides scatter/gather DMA functionality. This allows processor DMA reads/writes to/from non-contiguous memory blocks.

Table 7. DMA Channels

Peripheral	DMA Channels
SPORTs	16
IDP/PDAP	8
SPI	2
UART	2
External Port	2
Link Port	2
Accelerators	2
Memory-to-Memory	2
MLB ¹	31

¹Automotive models only.

IIR Accelerator

The IIR (infinite impulse response) accelerator consists of a 1440 word coefficient memory for storage of biquad coefficients, a data memory for storing the intermediate data, and one MAC unit. A controller manages the accelerator. The IIR accelerator runs at the peripheral clock frequency.

FFT Accelerator

FFT accelerator implements radix-2 complex/real input, complex output FFT with no core intervention. The FFT accelerator runs at the peripheral clock frequency.

FIR Accelerator

The FIR (finite impulse response) accelerator consists of a 1024 word coefficient memory, a 1024 word deep delay line for the data, and four MAC units. A controller manages the accelerator. The FIR accelerator runs at the peripheral clock frequency.

SYSTEM DESIGN

The following sections provide an introduction to system design options and power supply issues.

Program Booting

The internal memory of the ADSP-21469 boots at system power-up from an 8-bit EPROM via the external port, link port, an SPI master, or an SPI slave. Booting is determined by the boot configuration (BOOTCFG2-0) pins in [Table 8](#).

Table 8. Boot Mode Selection

BOOTCFG2-0	Booting Mode
000	SPI Slave Boot
001	SPI Master Boot
010	AMI Boot (for 8-bit Flash boot)
011	No boot occurs, processor executes from internal ROM after reset
100	Link Port 0 Boot
101	Reserved

The Running Reset feature allows a user to perform a reset of the processor core and peripherals, without resetting the PLL and DDR2 DRAM controller or performing a Boot. The functionality of the $\overline{\text{RESETOUT}}$ pin also acts as the input for initiating a Running Reset. For more information, see the *ADSP-214xx SHARC Processor Hardware Reference*.

Power Supplies

The processors have separate power supply connections for the internal (V_{DD_INT}), external (V_{DD_EXT}), and analog (V_{DD_A}) power supplies. The internal and analog supplies must meet the V_{DD_INT} specifications. The external supply must meet the V_{DD_EXT} specification. All external supply pins must be connected to the same power supply.

Note that the analog supply pin (V_{DD_A}) powers the processor's internal clock generator PLL. To produce a stable clock, it is recommended that PCB designs use an external filter circuit for the V_{DD_A} pin. Place the filter components as close as possible to the V_{DD_A}/AGND pins. For an example circuit, see [Figure 3](#). (A recommended ferrite chip is the muRata BLM18AG102SN1D).

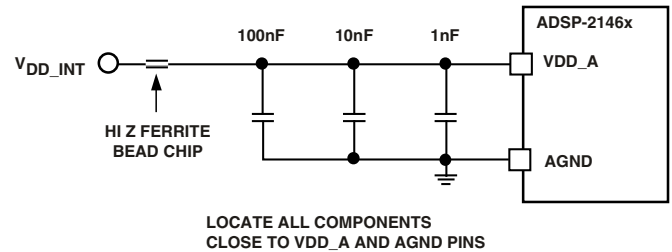

Figure 3. Analog Power (V_{DD_A}) Filter Circuit

To reduce noise coupling, the PCB should use a parallel pair of power and ground planes for V_{DD_INT} and GND. Use wide traces to connect the bypass capacitors to the analog power (V_{DD_A}) and ground (AGND) pins. Note that the V_{DD_A} and AGND pins specified in [Figure 3](#) are inputs to the processor and not the analog ground plane on the board—the AGND pin should connect directly to digital ground (GND) at the chip.

Target Board JTAG Emulator Connector

Analog Devices DSP Tools product line of JTAG emulators uses the IEEE 1149.1 JTAG test access port of the ADSP-21469 processors to monitor and control the target board processor during emulation. Analog Devices DSP Tools product line of JTAG emulators provides emulation at full processor speed, allowing inspection and modification of memory, registers, and processor stacks. The processor's JTAG interface ensures that the emulator will not affect target system loading or timing.

For complete information on Analog Devices' SHARC DSP Tools product line of JTAG emulator operation, see the appropriate Emulator Hardware User's Guide.

DEVELOPMENT TOOLS

The ADSP-21469 processor is supported with a complete set of CROSSCORE[®] software and hardware development tools, including Analog Devices emulators and VisualDSP++[®] development environment. The same emulator hardware that supports other SHARC processors also fully emulates the ADSP-21469 processors.

EZ-KIT Lite Evaluation Board

For evaluation of the processors, use the EZ-KIT Lite[®] board being developed by Analog Devices. The board comes with on-chip emulation capabilities and is equipped to enable software development. Multiple daughter cards are available.

Designing an Emulator-Compatible DSP Board (Target)

The Analog Devices family of emulators are tools that every DSP developer needs to test and debug hardware and software systems. Analog Devices has supplied an IEEE 1149.1 JTAG Test Access Port (TAP) on each JTAG DSP. Nonintrusive in-circuit emulation is assured by the use of the processor's JTAG interface—the emulator does not affect target system loading or timing. The emulator uses the TAP to access the internal features of the processor, allowing the developer to load code, set breakpoints, observe variables, observe memory, and examine registers. The processor must be halted to send data and commands, but once an operation has been completed by the emulator, the DSP system is set running at full speed with no impact on system timing.

To use these emulators, the target board must include a header that connects the DSP's JTAG port to the emulator.

For details on target board design issues including mechanical layout, single processor connections, signal buffering, signal termination, and emulator pod logic, see the *EE-68: Analog Devices JTAG Emulation Technical Reference* on the Analog Devices website (www.analog.com)—use site search on “EE-68.” This document is updated regularly to keep pace with improvements to emulator support.

Evaluation Kit

Analog Devices offers a range of EZ-KIT Lite[®] evaluation platforms to use as a cost effective method to learn more about developing or prototyping applications with Analog Devices processors, platforms, and software tools. Each EZ-KIT Lite includes an evaluation board along with an evaluation suite of the VisualDSP++[®] development and debugging environment with the C/C++ compiler, assembler, and linker. Also included are sample application programs, power supply, and a USB cable. All evaluation versions of the software tools are limited for use only with the EZ-KIT Lite product.

The USB controller on the EZ-KIT Lite board connects the board to the USB port of the user's PC, enabling the VisualDSP++ evaluation suite to emulate the on-board processor in-circuit. This permits the customer to download, execute, and debug programs for the EZ-KIT Lite system. It also allows in-circuit programming of the on-board Flash device to store user-specific boot code, enabling the board to run as a stand-alone unit without being connected to the PC.

With a full version of VisualDSP++ installed (sold separately), engineers can develop software for the EZ-KIT Lite or any custom defined system. Connecting one of Analog Devices JTAG emulators to the EZ-KIT Lite board enables high speed, non-intrusive emulation.

ADDITIONAL INFORMATION

This data sheet provides a general overview of the ADSP-21469 architecture and functionality. For detailed information on the ADSP-21469 family core architecture and instruction set, refer to the *SHARC Processor Programming Reference*.

RELATED SIGNAL CHAINS

A *signal chain* is a series of signal-conditioning electronic components that receive input (data acquired from sampling either real-time phenomena or from stored data) in tandem, with the output of one portion of the chain supplying input to the next. Signal chains are often used in signal processing applications to gather and process data or to apply system controls based on analysis of real-time phenomena. For more information about this term and related topics, see the "signal chain" entry in [Wikipedia](#) or the [Glossary of EE Terms](#) on the Analog Devices website.

Analog Devices eases signal processing system development by providing signal processing components that are designed to work together well. A tool for viewing relationships between specific applications and related components is available on the www.analog.com website.

The Application Signal Chains page in the Circuits from the Lab[™] site (<http://www.analog.com/signalchains>) provides:

- Graphical circuit block diagram presentation of signal chains for a variety of circuit types and applications
- Drill down links for components in each chain to selection guides and application information
- Reference designs applying best practice design techniques

PIN FUNCTION DESCRIPTIONS

UNUSED DDR2 PINS

When the DDR2 controller is not used:

- Leave the DDR2 signal pins floating.
- Internally, three-state the DDR2 I/O signals. This can be done by setting the DIS_DDRCTL bit of DDR2CTL0 register.
- Power down the receive path by setting the PWD bits of the DDR2PADCTLx register.
- Connect the V_{DD_DDR2} pins to the V_{DD_INT} supply.
- Leave V_{REF} floating/unconnected.

Table 9. Pin Descriptions

Name	Type	State During/ After Reset	Description
AMI_ADDR ₂₃₋₀	I/O/T (ipu)	High-Z/driven low (boot)	External Address. The processor outputs addresses for external memory and peripherals on these pins. The data pins can be multiplexed to support the PDAP (I) and PWM (O). After reset, all AMI_ADDR ₂₃₋₀ pins are in external memory interface mode and FLAG(0-3) pins are in FLAGS mode (default). When configured in the IDP_PDAP_CTL register, IDP channel 0 scans the AMI_ADDR ₂₃₋₀ pins for parallel input data. Unused AMI pins can be left unconnected.
AMI_DATA ₇₋₀	I/O/T (ipu)	High-Z	External Data. The data pins can be multiplexed to support the external memory interface data (I/O), the PDAP (I), FLAGS (I/O) and PWM (O). After reset, all AMI_DATA pins are in EMIF mode and FLAG(0-3) pins are in FLAGS mode (default). Unused AMI pins can be left unconnected.
AMI_ACK	I (ipu)		Memory Acknowledge (AMI_ACK). External devices can deassert AMI_ACK (low) to add wait states to an external memory access. AMI_ACK is used by I/O devices, memory controllers, or other peripherals to hold off completion of an external memory access. Unused AMI pins can be left unconnected.
$\overline{\text{AMI_MS}}_{0-1}$	O/T (ipu)	High-Z	Memory Select Lines 0-1. These lines are asserted (low) as chip selects for the corresponding banks of external memory on the AMI interface. The $\overline{\text{MS}}_{1-0}$ lines are decoded memory address lines that change at the same time as the other address lines. When no external memory access is occurring the $\overline{\text{MS}}_{1-0}$ lines are inactive; they are active however when a conditional memory access instruction is executed, whether or not the condition is true. Unused AMI pins can be left unconnected. The $\overline{\text{MS}}_1$ pin can be used in EPORT/FLASH boot mode. For more information, see the <i>ADSP-214xx SHARC Processor Hardware Reference</i> .
$\overline{\text{AMI_RD}}$	O/T (ipu)	High-Z	AMI Port Read Enable. $\overline{\text{AMI_RD}}$ is asserted whenever the processor reads a word from external memory.
$\overline{\text{AMI_WR}}$	O/T (ipu)	High-Z	External Port Write Enable. $\overline{\text{AMI_WR}}$ is asserted when the processor writes a word to external memory.
FLAG[0]/ $\overline{\text{IRQ0}}$	I/O (ipu)	FLAG[0] INPUT	FLAG0/Interrupt Request0.
FLAG[1]/ $\overline{\text{IRQ1}}$	I/O (ipu)	FLAG[1] INPUT	FLAG1/Interrupt Request1.
FLAG[2]/ $\overline{\text{IRQ2}}$ / $\overline{\text{AMI_MS2}}$	I/O (ipu)	FLAG[2] INPUT	FLAG2/Interrupt Request2/Async Memory Select2.
FLAG[3]/TMREXP/ $\overline{\text{AMI_MS3}}$	I/O (ipu)	FLAG[3] INPUT	FLAG3/Timer Expired/Async Memory Select3.

The following symbols appear in the Type column of Table 9: **A** = asynchronous, **I** = input, **O** = output, **S** = synchronous, **A/D** = active drive, **O/D** = open-drain, and **T** = three-state, **ipd** = internal pull-down resistor, **ipu** = internal pull-up resistor.

The internal pull-up (ipu) and internal pull-down (ipd) resistors are designed to hold the internal path from the pins at the expected logic levels. To pull-up or pull-down the external pads to the expected logic levels, use external resistors. Internal pull-up/pull-down resistors cannot be enabled/disabled and the value of these resistors cannot be programmed. The range of an ipu resistor can be between 26 k Ω –63 k Ω . The range of an ipd resistor can be between 31 k Ω –85 k Ω .

In this table, the DDR2 pins are SSTL18 compliant. All other pins are LVTTTL compliant.

Table 9. Pin Descriptions (Continued)

Name	Type	State During/ After Reset	Description
DDR2_ADDR ₁₅₋₀	O/T	High-Z/driven low	DDR2 Address. DDR2 address pins.
DDR2_BA ₂₋₀	O/T	High-Z/driven low	DDR2 Bank Address Input. Defines which internal bank an ACTIVATE, READ, WRITE, or PRECHARGE command is being applied to. BA ₂₋₀ define which mode registers, including MR, EMR, EMR(2), and EMR(3) are loaded during the LOAD MODE REGISTER command.
$\overline{\text{DDR2_CAS}}$	O/T	High-Z/driven high	DDR2 Column Address Strobe. Connect to $\overline{\text{DDR2_CAS}}$ pin; in conjunction with other DDR2 command pins, defines the operation for the DDR2 to perform.
DDR2_CKE	O/T	High-Z/driven low	DDR2 Clock Enable Output to DDR2. Active high signal. Connect to DDR2 CKE signal.
$\overline{\text{DDR2_CS}}_{3-0}$	O/T	High-Z/driven high	DDR2 Chip Select. All commands are masked when $\overline{\text{DDR2_CS}}_{3-0}$ is driven high. $\overline{\text{DDR2_CS}}_{3-0}$ are decoded memory address lines. Each $\overline{\text{DDR2_CS}}_{3-0}$ line selects the corresponding external bank.
DDR2_DATA ₁₅₋₀	I/O/T	High-Z	DDR2 Data In/Out. Connect to corresponding DDR2_DATA pins.
DDR2_DM ₁₋₀	O/T	High-Z/driven high	DDR2 Input Data Mask. Mask for the DDR2 write data if driven high. Sampled on both edges of DDR2_DQS at DDR2 side. DM0 corresponds to DDR2_DATA 7–0 and DM1 corresponds to DDR2_DATA 15–8.
DDR2_DQS ₁₋₀ $\overline{\text{DDR2_DQS}}_{1-0}$	I/O/T (Differential)	High-Z	Data Strobe. Output with Write Data. Input with Read Data. DQS0 corresponds to DDR2_DATA 7–0 and DQS1 corresponds to DDR2_DATA 15–8. Based on software control via the DDR2CTL3 register, this pin can be single-ended or differential.
$\overline{\text{DDR2_RAS}}$	O/T	High-Z/driven high	DDR2 Row Address Strobe. Connect to $\overline{\text{DDR2_RAS}}$ pin; in conjunction with other DDR2 command pins, defines the operation for the DDR2 to perform.
$\overline{\text{DDR2_WE}}$	O/T	High-Z/driven high	DDR2 Write Enable. Connect to $\overline{\text{DDR2_WE}}$ pin; in conjunction with other DDR2 command pins, defines the operation for the DDR2 to perform.
DDR2_CLK0, $\overline{\text{DDR2_CLK}}_0$, DDR2_CLK1, $\overline{\text{DDR2_CLK}}_1$	O/T (Differential)	High-Z/driven low	DDR2 Memory Clocks. Two differential outputs available via software control (DDR2CTL0 register). Free running, minimum frequency not guaranteed during reset.
DDR2_ODT	O/T	High-Z/driven low	DDR2 On Die Termination. ODT pin when driven high (along with other requirements) enables the DDR2 termination resistances. ODT is enabled/disabled regardless of read or write commands.

The following symbols appear in the Type column of Table 9: **A** = asynchronous, **I** = input, **O** = output, **S** = synchronous, **A/D** = active drive, **O/D** = open-drain, and **T** = three-state, **ipd** = internal pull-down resistor, **ipu** = internal pull-up resistor.

The internal pull-up (ipu) and internal pull-down (ipd) resistors are designed to hold the internal path from the pins at the expected logic levels. To pull-up or pull-down the external pads to the expected logic levels, use external resistors. Internal pull-up/pull-down resistors cannot be enabled/disabled and the value of these resistors cannot be programmed. The range of an ipu resistor can be between 26 k Ω –63 k Ω . The range of an ipd resistor can be between 31 k Ω –85 k Ω .

In this table, the DDR2 pins are SSTL18 compliant. All other pins are LVTTTL compliant.

ADSP-21469

Table 9. Pin Descriptions (Continued)

Name	Type	State During/ After Reset	Description
DAI_P20-1	I/O/T (ipu)	High-Z	Digital Applications Interface. These pins provide the physical interface to the DAI SRU. The DAI SRU configuration registers define the combination of on-chip audio-centric peripheral inputs or outputs connected to the pin and to the pin's output enable. The configuration registers of these peripherals then determine the exact behavior of the pin. Any input or output signal present in the DAI SRU may be routed to any of these pins. The DAI SRU provides the connection from the serial ports, the S/PDIF module, input data ports (2), and the precision clock generators (4), to the DAI_P20-1 pins.
DPI_P14-1	I/O/T (ipu)	High-Z	Digital Peripheral Interface. These pins provide the physical interface to the DPI SRU. The DPI SRU configuration registers define the combination of on-chip peripheral inputs or outputs connected to the pin and to the pin's output enable. The configuration registers of these peripherals then determines the exact behavior of the pin. Any input or output signal present in the DPI SRU may be routed to any of these pins. The DPI SRU provides the connection from the timers (2), SPIs (2), UART (1), flags (12), and general-purpose I/O (9) to the DPI_P14-1 pins.
LDAT07-0 LDAT17-0	I/O/T (ipd)	High-Z	Link Port Data (Link Ports 0-1). When configured as a transmitter, the port drives both the data lines.
LCLK0 LCLK1	I/O/T (ipd)	High-Z	Link Port Clock (Link Ports 0-1). Allows asynchronous data transfers. When configured as a transmitter, the port drives LCLKx lines. An external 25 kΩ pull-down resistor is required for the proper operation of this pin.
LACK0 LACK1	I/O/T (ipd)	High-Z	Link Port Acknowledge (Link Port 0-1). Provides handshaking. When the link ports are configured as a receiver, the port drives the LACKx line. An external 25 kΩ pull-down resistor is required for the proper operation of this pin.
THD_P	I		Thermal Diode Anode. If unused, can be left floating.
THD_M	O		Thermal Diode Cathode. If unused, can be left floating.
MLBCLK ¹	I (ipd)		Media Local Bus Clock. This clock is generated by the MLB controller that is synchronized to the MOST network and provides the timing for the entire MLB interface. 49.152 MHz at Fs = 48 kHz. If unused, can be left floating.
MLBDAT ¹	I/O/T (ipd) in 3 pin mode. I/T (ipd) in 5 pin mode.	High-Z	Media Local Bus Data. The MLBDAT line is driven by the transmitting MLB device and is received by all other MLB devices including the MLB controller. The MLBDAT line carries the actual data. In 5-pin MLB mode, this pin is an input only. If unused, can be left floating.
MLBSIG ¹	I/O/T (ipd) in 3 pin mode. I/T(ipd) in 5 pin mode.	High-Z	Media Local Bus Signal. This is a multiplexed signal which carries the Channel/ Address generated by the MLB Controller, as well as the Command and RxStatus bytes from MLB devices. In 5-pin mode, this pin is an input only. If unused, can be left floating.
MLBDO ¹	O/T (ipd)	High-Z	Media Local Bus Data Output (in 5 pin mode). This pin is used only in 5-pin MLB mode. This serves as the output data pin in 5-pin mode. If unused, can be left floating.
MLBSO ¹	O/T (ipd)	High-Z	Media Local Bus Signal Output (in 5 pin mode). This pin is used only in 5-pin MLB mode. This serves as the output signal pin in 5-pin mode. If unused, can be left floating.

The following symbols appear in the Type column of Table 9: **A** = asynchronous, **I** = input, **O** = output, **S** = synchronous, **A/D** = active drive, **O/D** = open-drain, and **T** = three-state, **ipd** = internal pull-down resistor, **ipu** = internal pull-up resistor.

The internal pull-up (ipu) and internal pull-down (ipd) resistors are designed to hold the internal path from the pins at the expected logic levels. To pull-up or pull-down the external pads to the expected logic levels, use external resistors. Internal pull-up/pull-down resistors cannot be enabled/disabled and the value of these resistors cannot be programmed. The range of an ipu resistor can be between 26 kΩ-63 kΩ. The range of an ipd resistor can be between 31 kΩ-85 kΩ.

In this table, the DDR2 pins are SSTL18 compliant. All other pins are LVTTTL compliant.

Table 9. Pin Descriptions (Continued)

Name	Type	State During/After Reset	Description
TDI	I (ipu)	High-Z	Test Data Input (JTAG). Provides serial data for the boundary scan logic.
TDO	O /T		Test Data Output (JTAG). Serial scan output of the boundary scan path.
TMS	I (ipu)		Test Mode Select (JTAG). Used to control the test state machine.
TCK	I		Test Clock (JTAG). Provides a clock for JTAG boundary scan. TCK must be asserted (pulsed low) after power-up or held low for proper operation of the device.
$\overline{\text{TRST}}$	I (ipu)		Test Reset (JTAG). Resets the test state machine. $\overline{\text{TRST}}$ must be asserted (pulsed low) after power-up or held low for proper operation of the processor.
$\overline{\text{EMU}}$	O/T (ipu)		Emulation Status. Must be connected to the ADSP-21469 Analog Devices DSP Tools product line of JTAG emulators target board connector only.
CLK_CFG ₁₋₀	I		Core to CLKIN Ratio Control. These pins set the start up clock frequency. Note that the operating frequency can be changed by programming the PLL multiplier and divider in the PMCTL register at any time after the core comes out of reset. The allowed values are: 00 = 6:1 01 = 32:1 10 = 16:1 11 = reserved
CLKIN	I		Local Clock In. Used in conjunction with XTAL. CLKIN is the clock input. It configures the processors to use either its internal clock generator or an external clock source. Connecting the necessary components to CLKIN and XTAL enables the internal clock generator. Connecting the external clock to CLKIN while leaving XTAL unconnected configures the processors to use the external clock source such as an external clock oscillator. CLKIN may not be halted, changed, or operated below the specified frequency.
XTAL	O		Crystal Oscillator Terminal. Used in conjunction with CLKIN to drive an external crystal.
$\overline{\text{RESET}}$	I		Processor Reset. Resets the processor to a known state. Upon deassertion, there is a 4096 CLKIN cycle latency for the PLL to lock. After this time, the core begins program execution from the hardware reset vector address. The $\overline{\text{RESET}}$ input must be asserted (low) at power-up.
$\overline{\text{RESETOUT}}/\text{RUNRSTIN}$	I/O (ipu)		Reset Out/Running Reset In. The default setting on this pin is reset out. This pin also has a second function as RUNRSTIN which is enabled by setting bit 0 of the RUNRSTCTL register. For more information, see the <i>ADSP-214xx SHARC Processor Hardware Reference</i> .
BOOT_CFG ₂₋₀	I		Boot Configuration Select. These pins select the boot mode for the processor. The BOOT_CFG pins must be valid before $\overline{\text{RESET}}$ (hardware and software) is de-asserted.

The following symbols appear in the Type column of [Table 9](#): **A** = asynchronous, **I** = input, **O** = output, **S** = synchronous, **A/D** = active drive, **O/D** = open-drain, and **T** = three-state, **ipd** = internal pull-down resistor, **ipu** = internal pull-up resistor. The internal pull-up (ipu) and internal pull-down (ipd) resistors are designed to hold the internal path from the pins at the expected logic levels. To pull-up or pull-down the external pads to the expected logic levels, use external resistors. Internal pull-up/pull-down resistors cannot be enabled/disabled and the value of these resistors cannot be programmed. The range of an ipu resistor can be between 26 k Ω –63 k Ω . The range of an ipd resistor can be between 31 k Ω –85 k Ω . In this table, the DDR2 pins are SSTL18 compliant. All other pins are LVTTTL compliant.

¹The MLB pins are only available on automotive models of the ADSP-21469 processors. These pins are NC (no connect) on the standard models. For more information, see [CSP_BGA Ball Assignment—Automotive Models on Page 63](#), and [CSP_BGA Ball Assignment—Standard Models on Page 66](#).

ADSP-21469

Table 10. Pin List, Power and Ground

Name	Type	Description
V _{DD_INT}	P	Internal Power
V _{DD_EXT}	P	External Power
V _{DD_A}	P	Analog Power for PLL
V _{DD_THD}	P	Thermal Diode Power
V _{DD_DDR2} ¹	P	DDR2 Interface Power
V _{REF}	P	DDR2 Input Voltage Reference
GND	G	Ground
AGND	G	Analog Ground

¹Applies to DDR2 signals.

SPECIFICATIONS

OPERATING CONDITIONS

Parameter ¹	Description	450 MHz			400 MHz			Unit
		Min	Nom	Max	Min	Nom	Max	
V _{DD_INT}	Internal (Core) Supply Voltage	1.05	1.1	1.15	1.0	1.05	1.1	V
V _{DD_EXT}	External (I/O) Supply Voltage	3.13	3.3	3.47	3.13	3.3	3.47	V
V _{DD_A} ²	Analog Power Supply Voltage	1.05	1.1	1.15	1.0	1.05	1.1	V
V _{DD_DDR2} ^{3, 4}	DDR2 Controller Supply Voltage	1.7	1.8	1.9	1.7	1.8	1.9	V
V _{DD_THD}	Thermal Diode Supply Voltage	3.13	3.3	3.47	3.13	3.3	3.47	V
V _{REF}	DDR2 Reference Voltage	0.84	0.9	0.96	0.84	0.9	0.96	V
V _{IH} ⁵	High Level Input Voltage @ V _{DD_EXT} = Max	2.0			2.0			V
V _{IL} ⁵	Low Level Input Voltage @ V _{DD_EXT} = Min			0.8			0.8	V
V _{IH_CLKIN} ⁶	High Level Input Voltage @ V _{DD_EXT} = Max	2.0			2.0			V
V _{IL_CLKIN} ⁶	Low Level Input Voltage @ V _{DD_EXT} = Min			1.32			1.32	V
V _{IL_DDR2} (DC)	DC Low Level Input Voltage			V _{REF} - 0.125			V _{REF} - 0.125	V
V _{IH_DDR2} (DC)	DC High Level Input Voltage	V _{REF} + 0.125			V _{REF} + 0.125			V
V _{IL_DDR2} (AC)	AC Low Level Input Voltage			V _{REF} - 0.25			V _{REF} - 0.25	V
V _{IH_DDR2} (AC)	AC High Level Input Voltage	V _{REF} + 0.25			V _{REF} + 0.25			V
T _J	Junction Temperature 324-Lead CSP_BGA @ T _{AMBIENT} 0°C to +70°C	0		115	0		110	°C
T _J	Junction Temperature 324-Lead CSP_BGA @ T _{AMBIENT} -40°C to +85°C	N/A		N/A	-40		125	°C

¹ Specifications subject to change without notice.

² See [Figure 3 on Page 10](#) for an example filter circuit.

³ Applies to DDR2 signals.

⁴ If unused, see [Unused DDR2 Pins on Page 12](#).

⁵ Applies to input and bidirectional pins: AMI_ADDR23-0, AMI_DATA7-0, FLAG3-0, DAI_Px, DPI_Px, BOOTCFGx, CLKCFGx, (RUNRSTIN), RESET, TCK, TMS, TDI, TRST.

⁶ Applies to input pin CLKIN.

ADSP-21469

ELECTRICAL CHARACTERISTICS

Parameter ¹	Description	Test Conditions	450 MHz		400 MHz		Unit
			Min	Max	Min	Max	
V _{OH} ²	High Level Output Voltage	@ V _{DD_EXT} = Min, I _{OH} = -1.0 mA ³	2.4		2.4		V
V _{OL} ²	Low Level Output Voltage	@ V _{DD_EXT} = Min, I _{OL} = 1.0 mA ³		0.4		0.4	V
V _{OH_DDR2}	High Level Output Voltage for DDR2	@ V _{DD_DDR} = Min, I _{OH} = -13.4 mA	1.4		1.4		V
V _{OL_DDR2}	Low Level Output Voltage for DDR2	@ V _{DD_DDR} = Min, I _{OL} = 13.4 mA		0.29		0.29	V
I _{IH} ^{4,5}	High Level Input Current	@ V _{DD_EXT} = Max, V _{IN} = V _{DD_EXT} Max		10		10	μA
I _{IL} ^{4,6}	Low Level Input Current	@ V _{DD_EXT} = Max, V _{IN} = 0 V		10		10	μA
I _{ILPU} ⁵	Low Level Input Current Pull-up	@ V _{DD_EXT} = Max, V _{IN} = 0 V		200		200	μA
I _{IHPD} ⁶	High Level Input Current Pull-down	@ V _{DD_EXT} = Max, V _{IN} = V _{DD_EXT} Max		200		200	μA
I _{OZH} ^{7,8}	Three-State Leakage Current	@ V _{DD_EXT} /V _{DD_DDR} = Max, V _{IN} = V _{DD_EXT} /V _{DD_DDR} Max		10		10	μA
I _{OZL} ^{7,9}	Three-State Leakage Current	@ V _{DD_EXT} /V _{DD_DDR} = Max, V _{IN} = 0 V		10		10	μA
I _{OZLPU} ⁸	Three-State Leakage Current Pull-up	@ V _{DD_EXT} = Max, V _{IN} = 0 V		200		200	μA
I _{OZHDPD} ⁹	Three-State Leakage Current Pull-down	@ V _{DD_EXT} = Max, V _{IN} = V _{DD_EXT} Max		200		200	μA
I _{DD-INTYP} ^{10,11}	Supply Current (Internal)	f _{CLK} > 0 MHz		Table 12 + Table 13 × ASF		Table 12 + Table 13 × ASF	mA
I _{DD_A} ¹²	Supply Current (Analog)	V _{DD_A} = Max		10		10	mA
C _{IN} ^{13,14}	Input Capacitance	T _{CASE} = 25°C		5		5	pF

¹ Specifications subject to change without notice.

² Applies to output and bidirectional pins: AMI_ADDR23-0, AMI_DATA7-0, AMI_RD, AMI_WR, FLAG3-0, DAI_Px, DPI_Px, EMU, TDO.

³ See [Output Drive Currents on Page 58](#) for typical drive current capabilities.

⁴ Applies to input pins: BOOTCFGx, CLKCFGx, TCK, RESET, CLKIN.

⁵ Applies to input pins with internal pull-ups: TRST, TMS, TDI.

⁶ Applies to input pins with internal pull-downs: MLBCLK

⁷ Applies to three-statable pins: all DDR2 pins.

⁸ Applies to three-statable pins with pull-ups: DAI_Px, DPI_Px, EMU.

⁹ Applies to three-statable pins with pull-downs: MLBDAT, MLBSIG, MLBDO, MLBSO, LDAT07-0, LDAT17-0, LCLK0, LCLK1, LACK0, LACK1.

¹⁰ Typical internal current data reflects nominal operating conditions.

¹¹ See Engineer-to-Engineer Note "Estimating Power Dissipation for ADSP-2146x SHARC Processors" for further information.

¹² Characterized but not tested.

¹³ Applies to all signal pins.

¹⁴ Guaranteed, but not tested.

Total Power Dissipation

Total power dissipation has two components:

1. Internal power consumption
2. External power consumption

Internal power consumption also comprises two components:

1. Static, due to leakage current. [Table 12](#) shows the static current consumption ($I_{DD-STATIC}$) as a function of junction temperature (T_J) and core voltage (V_{DD_INT}).
2. Dynamic ($I_{DD-DYNAMIC}$), due to transistor switching characteristics and activity level of the processor. The activity level is reflected by the Activity Scaling Factor (ASF), which represents application code running on the processor core and having various levels of peripheral and external port activity ([Table 11](#)). Dynamic current consumption is calculated by scaling the specific application by the ASF and using baseline dynamic current consumption as a reference.

External power consumption is due to the switching activity of the external pins.

The ASF is combined with the CCLK frequency and V_{DD_INT} dependent data in [Table 13](#) to calculate this part. The second part is due to transistor switching in the peripheral clock (PCLK) domain, which is included in the I_{DD_INT} specification equation.

Table 11. Activity Scaling Factors (ASF)¹

Activity	Scaling Factor (ASF)
Idle	0.38
Low	0.58
High	1.23
Peak	1.35
Peak-typical (50:50) ²	0.87
Peak-typical (60:40)	0.94
Peak-typical (70:30)	1.00

¹ See *Estimating Power for SHARC Processors (EE-348)* for more information on the explanation of the power vectors specific to the ASF table.

² Ratio of continuous instruction loop (core) to DDR2 control code reads:writes.

Table 12. $I_{DD-STATIC}$ (mA)

T_J (°C) ¹	V_{DD_INT} (V) ¹				
	0.95 V	1.0 V	1.05 V	1.10 V	1.15 V
-45	72	91	110	140	167
-35	79	99	119	149	181
-25	89	109	131	163	198
-15	101	122	145	182	220
-5	115	140	166	206	249
5	134	162	192	237	284
15	158	189	223	273	326
25	186	222	260	318	377
35	218	259	302	367	434
45	258	305	354	428	503
55	305	359	413	497	582
65	360	421	484	578	675
75	424	496	566	674	781
85	502	580	660	783	904
95	586	683	768	912	1048
105	692	794	896	1054	1212
115	806	921	1036	1220	1394
125	939	1070	1198	1404	1601

¹ Valid temperature and voltage ranges are model-specific. See [Operating Conditions on Page 17](#).

ADSP-21469

Table 13. Baseline Dynamic Current in CCLK Domain (mA, with ASF = 1.0)¹

f _{CCLK} (MHz) ²	Voltage (V _{DD_INT}) ²				
	0.95 V	1.0 V	1.05 V	1.10 V	1.15 V
100	78	82	86	91	98
150	115	121	130	136	142
200	150	159	169	177	188
250	186	197	208	219	231
300	222	236	249	261	276
350	259	275	288	304	319
400	293	309	328	344	361
450	N/A	N/A	366	385	406

¹The values are not guaranteed as standalone maximum specifications. They must be combined with static current per the equations of [Electrical Characteristics on Page 18](#).

²Valid frequency and voltage ranges are model-specific. See [Operating Conditions on Page 17](#).

ABSOLUTE MAXIMUM RATINGS

Stresses greater than those listed in [Table 14](#) may cause permanent damage to the device. These are stress ratings only; functional operation of the device at these or any other conditions greater than those indicated in the operational sections of this specification is not implied. Exposure to absolute maximum rating conditions for extended periods may affect device reliability.

Table 14. Absolute Maximum Ratings

Parameter	Rating
Internal (Core) Supply Voltage (V _{DD_INT})	-0.3 V to +1.32 V
Analog (PLL) Supply Voltage (V _{DD_A})	-0.3 V to +1.15 V
External (I/O) Supply Voltage (V _{DD_EXT})	-0.3 V to +3.6 V
Thermal Diode Supply Voltage (V _{DD_THD})	-0.3 V to +3.6 V
DDR2 Controller Supply Voltage (V _{DD_DDR2})	-0.3 V to +1.9 V
DDR2 Input Voltage	-0.3 V to +1.9 V
Input Voltage	-0.3 V to +3.6 V
Output Voltage Swing	-0.3 V to V _{DD_EXT} + 0.5 V
Storage Temperature Range	-65°C to +150°C
Junction Temperature While Biased	125°C

ESD SENSITIVITY



ESD (electrostatic discharge) sensitive device. Charged devices and circuit boards can discharge without detection. Although this product features patented or proprietary protection circuitry, damage may occur on devices subjected to high energy ESD. Therefore, proper ESD precautions should be taken to avoid performance degradation or loss of functionality.

PACKAGE INFORMATION

The information presented in [Figure 4](#) provides details about the package branding for the ADSP-21469 processors. For a complete listing of product availability, see [Ordering Guide on Page 70](#).



Figure 4. Typical Package Brand

Table 15. Package Brand Information¹

Brand Key	Field Description
t	Temperature Range
pp	Package Type
Z	RoHS Compliant Option
cc	See Ordering Guide
vvvvvv.x	Assembly Lot Code
n.n	Silicon Revision
#	RoHS Compliant Designation
yyww	Date Code

¹Non-Automotive only. For branding information specific to Automotive products, contact Analog Devices Inc.

TIMING SPECIFICATIONS

Use the exact timing information given. Do not attempt to derive parameters from the addition or subtraction of others. While addition or subtraction would yield meaningful results for an individual device, the values given in this data sheet reflect statistical variations and worst cases. Consequently, it is not meaningful to add parameters to derive longer times. See [Figure 45 on Page 58](#) under **Test Conditions** for voltage reference levels.

In the following sections, *Switching Characteristics* specify how the processor changes its signals. Circuitry external to the processor must be designed for compatibility with these signal characteristics. Switching characteristics describe what the processor will do in a given circumstance. Use switching characteristics to ensure that any timing requirement of a device connected to the processor (such as memory) is satisfied.

In the following sections, *Timing Requirements* apply to signals that are controlled by circuitry external to the processor, such as the data input for a read operation. Timing requirements guarantee that the processor operates correctly with other devices.

Core Clock Requirements

The processor’s internal clock (a multiple of CLKIN) provides the clock signal for timing internal memory, processor core, and serial ports. During reset, program the ratio between the processor’s internal clock frequency and external (CLKIN) clock frequency with the CLK_CFG1–0 pins.

The processor’s internal clock switches at higher frequencies than the system input clock (CLKIN). To generate the internal clock, the processor uses an internal phase-locked loop (PLL, see [Figure 5](#)). This PLL-based clocking minimizes the skew between the system clock (CLKIN) signal and the processor’s internal clock.

Voltage Controlled Oscillator

In application designs, the PLL multiplier value should be selected in such a way that the VCO frequency never exceeds f_{VCO} specified in [Table 18](#).

- The product of CLKIN and PLLM must never exceed 1/2 of f_{VCO} (max) in [Table 18](#) if the input divider is not enabled (INDIV = 0).
- The product of CLKIN and PLLM must never exceed f_{VCO} (max) in [Table 18](#) if the input divider is enabled (INDIV = 1).

The VCO frequency is calculated as follows:

$$f_{VCO} = 2 \times PLLM \times f_{INPUT}$$

$$f_{CLK} = (2 \times PLLM \times f_{INPUT}) \div (PLLD)$$

where:

$$f_{VCO} = \text{VCO output}$$

PLLM = Multiplier value programmed in the PMCTL register. During reset, the PLLM value is derived from the ratio selected using the CLK_CFG pins in hardware.

PLLD = Divider value 2, 4, 8, or 16 based on the PLLD value programmed on the PMCTL register. During reset this value is 2.

$$f_{INPUT} = \text{input frequency to the PLL}$$

$$f_{INPUT} = \text{CLKIN when the input divider is disabled, or}$$

$$f_{INPUT} = \text{CLKIN} \div 2 \text{ when the input divider is enabled}$$

Note the definitions of the clock periods that are a function of CLKIN and the appropriate ratio control shown in and [Table 16](#). All of the timing specifications for the ADSP-21469 peripherals are defined in relation to t_{PCLK} . See the peripheral specific section for each peripheral’s timing information.

Table 16. Clock Periods

Timing Requirements	Description
t_{CK}	CLKIN Clock Period
t_{CCLK}	Processor Core Clock Period
t_{PCLK}	Peripheral Clock Period = $2 \times t_{CCLK}$

[Figure 5](#) shows core to CLKIN relationships with external oscillator or crystal. The shaded divider/multiplier blocks denote where clock ratios can be set through hardware or software using the power management control register (PMCTL). For more information, see the *ADSP-214xx SHARC Processor Hardware Reference*.

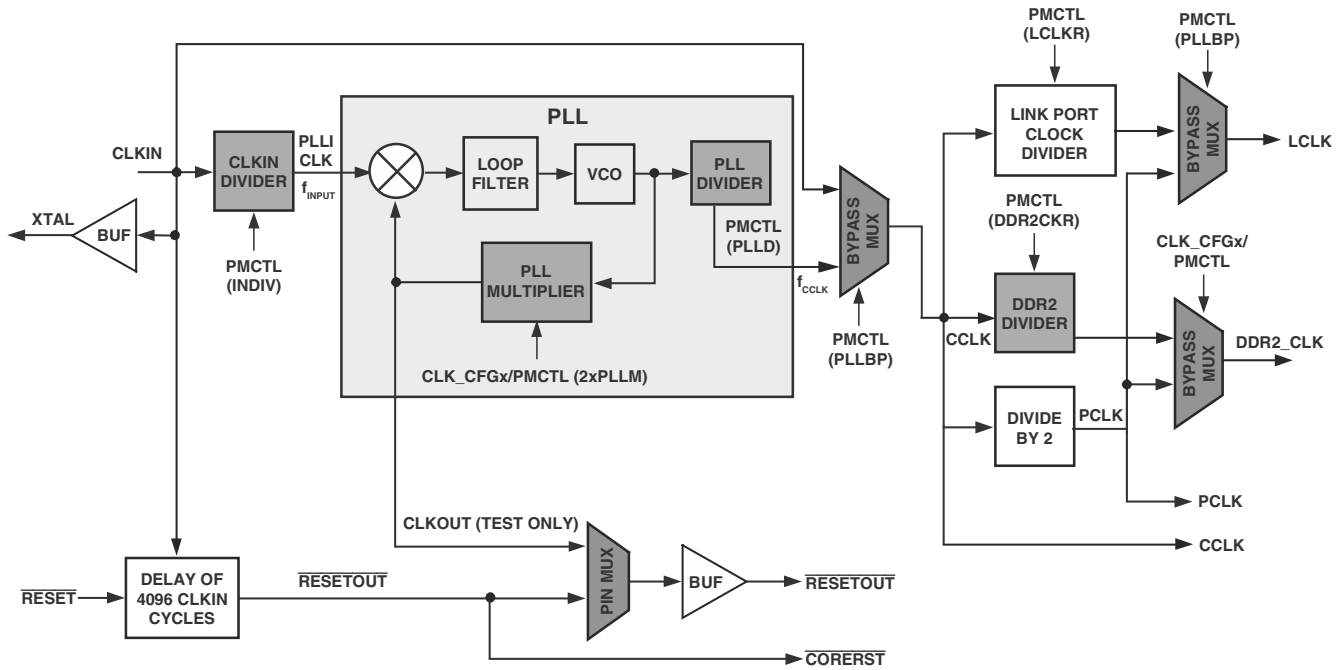

Figure 5. Core Clock and System Clock Relationship to CLKIN

Power-Up Sequencing

The timing requirements for processor startup are given in Table 17. While no specific power-up sequencing is required between V_{DD_EXT} , V_{DD_DDR2} , and V_{DD_INT} , there are some considerations that the system designs should take into account.

- No power supply should be powered up for an extended period of time (> 200 ms) before another supply starts to ramp up.
- If V_{DD_INT} power supply comes up after V_{DD_EXT} , any pin, such as RESETOUT and RESET, may actually drive momentarily until the V_{DD_INT} rail has powered up. Systems

sharing these signals on the board must determine if there are any issues that need to be addressed based on this behavior.

Note that during power-up, when the V_{DD_INT} power supply comes up after V_{DD_EXT} , a leakage current of the order of three-state leakage current pull-up, pull-down may be observed on any pin, even if that pin is an input only (for example the \overline{RESET} pin) until the V_{DD_INT} rail has powered up.

Table 17. Power Up Sequencing Timing Requirements (Processor Startup)

Parameter		Min	Max	Unit
<i>Timing Requirements</i>				
t_{RSTVDD}	\overline{RESET} Low Before V_{DD_INT} or V_{DD_EXT} or V_{DD_DDR2} On	0		ms
$t_{VDD-EVDD}$	V_{DD_INT} On Before V_{DD_EXT}	-200	+200	ms
$t_{EVDD_DDR2VDD}$	V_{DD_EXT} On Before V_{DD_DDR2}	-200	+200	ms
t_{CLKVDD}^1	CLKIN Valid After V_{DD_INT} or V_{DD_EXT} or V_{DD_DDR2} Valid	0	200	ms
t_{CLKRST}	CLKIN Valid Before \overline{RESET} Deasserted	10^2		ms
t_{PLLST}	PLL Control Setup Before \overline{RESET} Deasserted	20^3		ms
<i>Switching Characteristic</i>				
$t_{CORERST}$	Core Reset Deasserted After \overline{RESET} Deasserted	$4096 \times t_{CK} + 2 \times t_{CCLK}^{4,5}$		ms

¹ Valid V_{DD_INT} assumes that the supply is fully ramped to its nominal value. Voltage ramp rates can vary from microseconds to hundreds of milliseconds depending on the design of the power supply subsystem.
² Assumes a stable CLKIN signal, after meeting worst-case startup timing of crystal oscillators. Refer to your crystal oscillator manufacturer's data sheet for startup time. Assume a 25 ms maximum oscillator startup time if using the XTAL pin and internal oscillator circuit in conjunction with an external crystal.
³ Based on CLKIN cycles.
⁴ Applies after the power-up sequence is complete. Subsequent resets require a minimum of four CLKIN cycles for \overline{RESET} to be held low in order to properly initialize and propagate default states at all I/O pins.
⁵ The 4096 cycle count depends on t_{SRST} specification in Table 19. If setup time is not met, one additional CLKIN cycle may be added to the core reset time, resulting in 4097 cycles maximum.

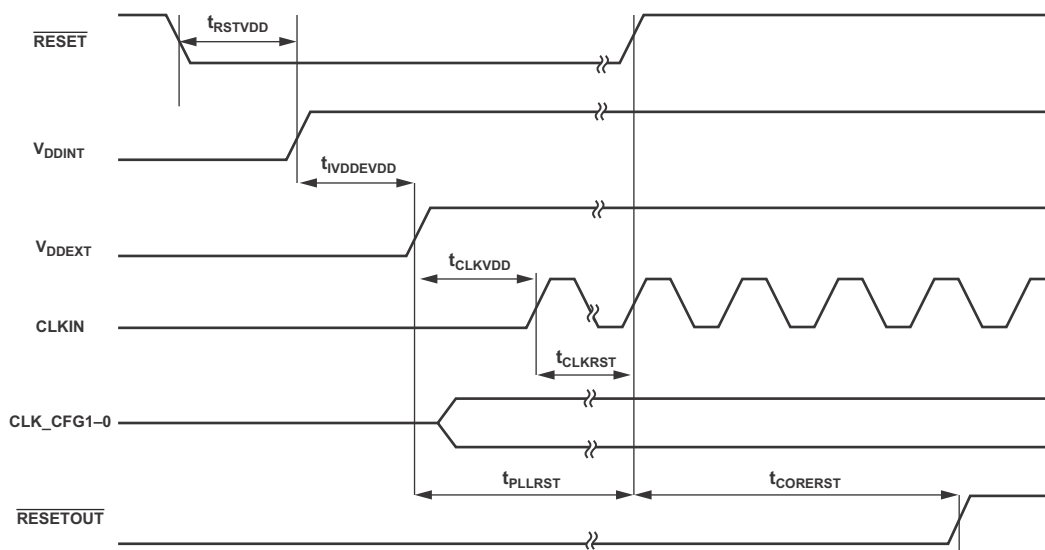

Figure 6. Power-Up Sequencing

ADSP-21469

Clock Input

Table 18. Clock Input

Parameter	400 MHz ¹		450 MHz ²		Unit	
	Min	Max	Min	Max		
<i>Timing Requirements</i>						
t_{CK}	CLKIN Period	15 ³	100	13.26	100	ns
t_{CKL}	CLKIN Width Low	7.5	45	6.63	45	ns
t_{CKH}	CLKIN Width High	7.5	45	6.63	45	ns
t_{CKRF}	CLKIN Rise/Fall (0.4 V to 2.0 V)		3 ⁴		3 ⁴	ns
t_{CCLK} ⁵	CCLK Period	2.5	10	2.22	10	ns
f_{VCO} ⁶	VCO Frequency	200	900	200	900	MHz
t_{CKJ} ^{7,8}	CLKIN Jitter Tolerance	-250	+250	-250	+250	ps

¹ Applies to all 400 MHz models. See [Ordering Guide on Page 70](#).

² Applies to all 450 MHz models. See [Ordering Guide on Page 70](#).

³ Applies only for CLK_CFG1-0 = 00 and default values for PLL control bits in PMCTL.

⁴ Guaranteed by simulation but not tested on silicon.

⁵ Any changes to PLL control bits in the PMCTL register must meet core clock timing specification t_{CCLK} .

⁶ See [Figure 5 on Page 22](#) for VCO diagram.

⁷ Actual input jitter should be combined with ac specifications for accurate timing analysis.

⁸ Jitter specification is maximum peak-to-peak time interval error (TIE) jitter.

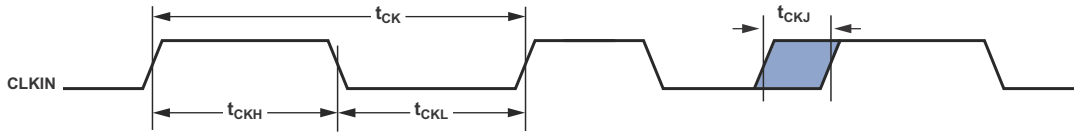
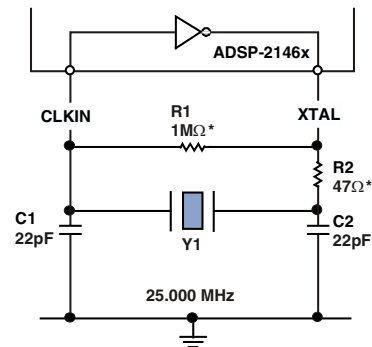

Figure 7. Clock Input

Clock Signals

The ADSP-21469 can use an external clock or a crystal. See the CLKIN pin description in [Table 9](#). Programs can configure the processor to use its internal clock generator by connecting the necessary components to CLKIN and XTAL. [Figure 8](#) shows the component connections used for a crystal operating in fundamental mode. Note that the clock rate is achieved using a 25 MHz crystal and a PLL multiplier ratio 16:1 (CCLK:CLKIN achieves a clock speed of 400 MHz).

To achieve the full core clock rate, programs need to configure the multiplier bits in the PMCTL register.



*TYPICAL VALUES

R2 SHOULD BE CHOSEN TO LIMIT CRYSTAL DRIVE POWER. REFER TO CRYSTAL MANUFACTURER'S SPECIFICATIONS

Figure 8. Recommended Circuit for Fundamental Mode Crystal Operation

Reset

Table 19. Reset

Parameter	Min	Max	Unit
<i>Timing Requirements</i>			
t_{WRST}^1 \overline{RESET} Pulse Width Low	$4 \times t_{CK}$		ns
t_{SRST} \overline{RESET} Setup Before CLKIN Low	8		ns

¹ Applies after the power-up sequence is complete. At power-up, the processor's internal phase-locked loop requires no more than 100 ms while \overline{RESET} is low, assuming stable V_{DD} and CLKIN (not including start-up time of external clock oscillator).

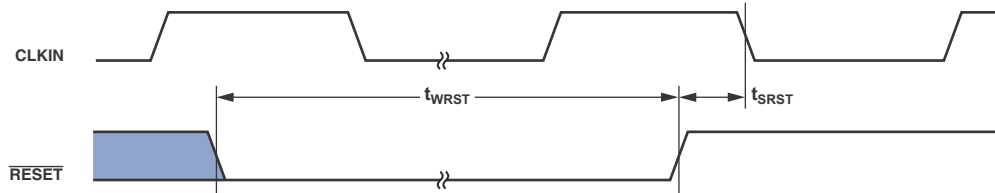

Figure 9. Reset

Running Reset

The following timing specification applies to $\overline{RESETOUT}/\overline{RUNRSTIN}$ pin when it is configured as $\overline{RUNRSTIN}$.

Table 20. Running Reset

Parameter	Min	Max	Unit
<i>Timing Requirements</i>			
$t_{WRUNRST}$ Running \overline{RESET} Pulse Width Low	$4 \times t_{CK}$		ns
$t_{SRUNRST}$ Running \overline{RESET} Setup Before CLKIN High	8		ns

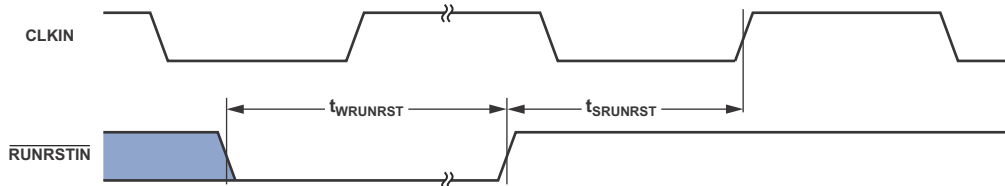

Figure 10. Running Reset

ADSP-21469

Interrupts

The following timing specification applies to the FLAG0, FLAG1, and FLAG2 pins when they are configured as $\overline{\text{IRQ0}}$, $\overline{\text{IRQ1}}$, and $\overline{\text{IRQ2}}$ interrupts as well as the DAI_P20–1 and DPI_P14–1 pins when they are configured as interrupts.

Table 21. Interrupts

Parameter	Min	Max	Unit
<i>Timing Requirement</i>			
t_{IPW} $\overline{\text{IRQx}}$ Pulse Width	$2 \times t_{\text{PCLK}} + 2$		ns

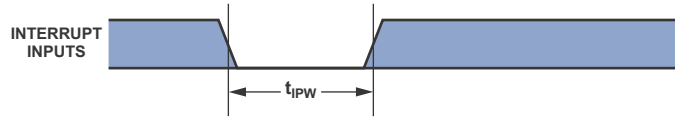

Figure 11. Interrupts

Core Timer

The following timing specification applies to FLAG3 when it is configured as the core timer (TMREXP).

Table 22. Core Timer

Parameter	Min	Max	Unit
<i>Switching Characteristic</i>			
t_{WCTIM} TMREXP Pulse Width	$4 \times t_{\text{PCLK}} - 1$		ns

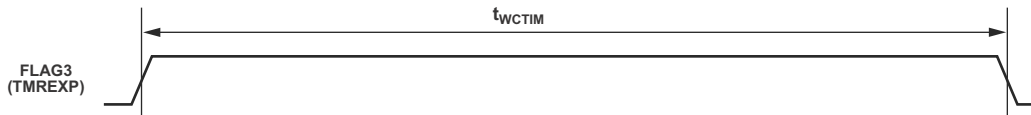

Figure 12. Core Timer

Timer PWM_OUT Cycle Timing

The following timing specification applies to Timer0 and Timer1 in PWM_OUT (pulse-width modulation) mode. Timer signals are routed to the DPI_P14-1 pins through the DPI SRU. Therefore, the timing specifications provided below are valid at the DPI_P14-1 pins.

Table 23. Timer PWM_OUT Timing

Parameter	Min	Max	Unit
<i>Switching Characteristic</i>			
t_{PWMO} Timer Pulse Width Output	$2 \times t_{PCLK} - 1.2$	$2 \times (2^{31} - 1) \times t_{PCLK}$	ns

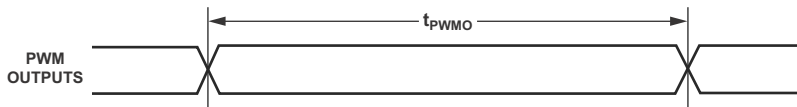

Figure 13. Timer PWM_OUT Timing

Timer WDTM_CAP Timing

The following timing specification applies to Timer0 and Timer1 in WDTM_CAP (pulse width count and capture) mode. Timer signals are routed to the DPI_P14-1 pins through the SRU. Therefore, the timing specifications provided below are valid at the DPI_P14-1 pins.

Table 24. Timer Width Capture Timing

Parameter	Min	Max	Unit
<i>Timing Requirement</i>			
t_{PWI} Timer Pulse Width	$2 \times t_{PCLK}$	$2 \times (2^{31} - 1) \times t_{PCLK}$	ns

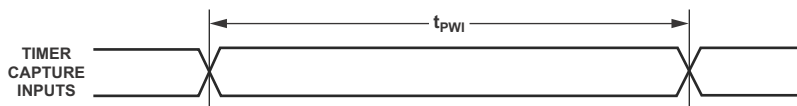

Figure 14. Timer Width Capture Timing

ADSP-21469

Pin to Pin Direct Routing (DAI and DPI)

For direct pin connections only (for example DAI_PB01_I to DAI_PB02_O).

Table 25. DAI and DPI Pin to Pin Routing

Parameter	Min	Max	Unit
<i>Timing Requirement</i>			
t_{DPIO} Delay DAI/DPI Pin Input Valid to DAI/DPI Output Valid	1.5	12	ns

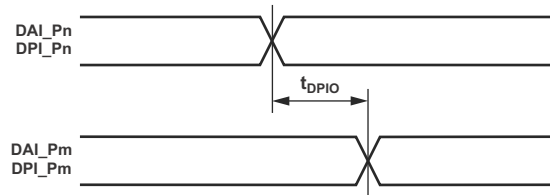

Figure 15. DAI and DPI Pin to Pin Direct Routing

Precision Clock Generator (Direct Pin Routing)

This timing is only valid when the SRU is configured such that the precision clock generator (PCG) takes its inputs directly from the DAI pins (via pin buffers) and sends its outputs directly to the DAI pins. For the other cases, where the PCG's

inputs and outputs are not directly routed to/from DAI pins (via pin buffers) there is no timing data available. All timing parameters and switching characteristics apply to external DAI pins (DAI_P01 – DAI_P20).

Table 26. Precision Clock Generator (Direct Pin Routing)

Parameter	Min	Max	Unit
<i>Timing Requirements</i>			
t_{PCGIW} Input Clock Period	$t_{CLK} \times 4$		ns
t_{STRIG} PCG Trigger Setup Before Falling Edge of PCG Input Clock	4.5		ns
t_{HTRIG} PCG Trigger Hold After Falling Edge of PCG Input Clock	3		ns
<i>Switching Characteristics</i>			
t_{DPCGIO} PCG Output Clock and Frame Sync Active Edge Delay After PCG Input Clock	2.5	10	ns
$t_{DTRIGCLK}$ PCG Output Clock Delay After PCG Trigger	$2.5 + (2.5 \times t_{PCGIP})$	$10 + (2.5 \times t_{PCGIP})$	ns
$t_{DTRIGFS}$ PCG Frame Sync Delay After PCG Trigger	$2.5 + ((2.5 + D - PH) \times t_{PCGIP})$	$10 + ((2.5 + D - PH) \times t_{PCGIP})$	ns
t_{PCGOW}^1 Output Clock Period	$2 \times t_{PCGIP} - 1$		ns

D = FSxDIV, PH = FSxPHASE. For more information, see the ADSP-214xx SHARC Processor Hardware Reference, "Precision Clock Generators" chapter.

¹Normal mode of operation.

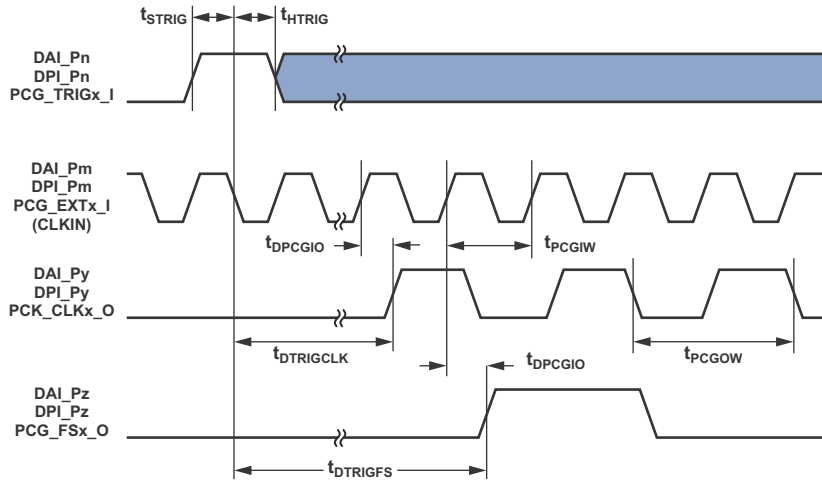

Figure 16. Precision Clock Generator (Direct Pin Routing)

ADSP-21469

Flags

The timing specifications provided below apply to AMI_ADDR23-0 and AMI_DATA7-0 when configured as FLAGS. See [Table 9 on Page 12](#) for more information on flag use.

Table 27. Flags

Parameter	Min	Max	Unit
<i>Timing Requirement</i>			
t_{FIPW} DPI_P14-1, AMI_ADDR23-0, AMI_DATA7-0, FLAG3-0 IN Pulse Width	$2 \times t_{PCLK} + 3$		ns
<i>Switching Characteristic</i>			
t_{FOPW} DPI_P14-1, AMI_ADDR23-0, AMI_DATA7-0, FLAG3-0 OUT Pulse Width	$2 \times t_{PCLK} - 3$		ns

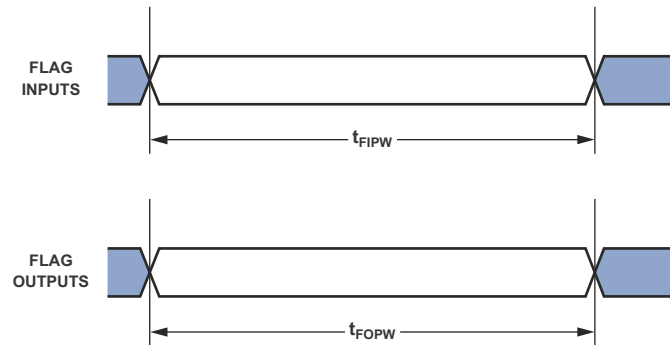

Figure 17. Flags

DDR2 SDRAM Read Cycle Timing

Table 28. DDR2 SDRAM Read Cycle Timing, $V_{DD-DDR2}$ Nominal 1.8 V

Parameter		200 MHz ¹		225 MHz ¹		Unit
		Min	Max	Min	Max	
<i>Timing Requirements</i>						
t_{AC}	DQ Output Access Time From CK/\overline{CK}	-1.0	0.7	-1.0	0.7	ns
t_{DQSCk}	DQS Output Access Time From CK/\overline{CK}	-1.0	0.7	-1.0	0.7	ns
t_{DQSQ}	DQS-DQ Skew for DQS and Associated DQ Signals		0.450		0.450	ns
t_{QH}	DQ, DQS Output Hold Time From DQS	1.9		1.71		ns
t_{RPRE}	Read Preamble	0.6		0.6		t_{CK}
t_{RPST}	Read Postamble	0.25		0.25		t_{CK}
<i>Switching Characteristics</i>						
t_{CK}	Clock Cycle Time	4.8		4.22		ns
t_{CH}	Minimum Clock Pulse Width	2.35	2.75	2.05	2.45	ns
t_{CL}	Maximum Clock Pulse Width	2.35	2.75	2.05	2.45	ns
t_{AS}	Address Setup Time	1.85		1.65		ns
t_{AH}	Address Hold Time	1.0		0.9		ns

¹In order to ensure proper operation of the DDR2, all the DDR2 guidelines have to be strictly followed (see Engineer-to-Engineer Note EE-349).

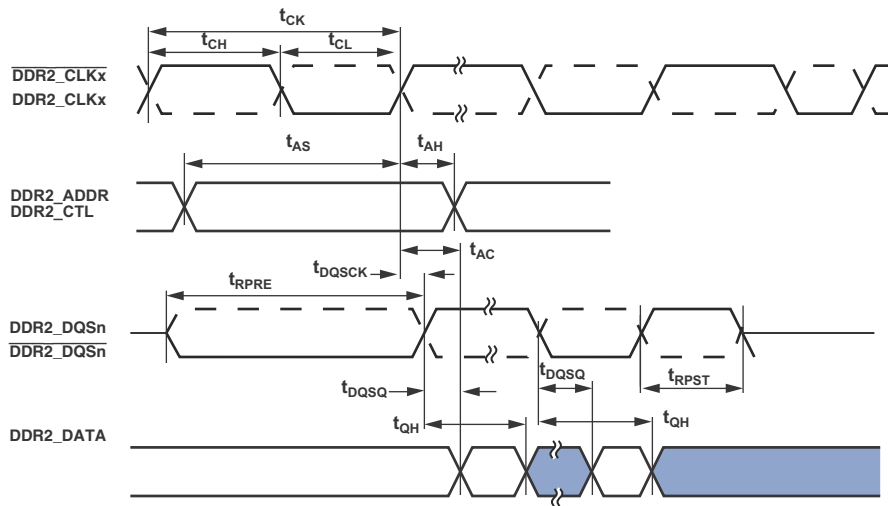

Figure 18. DDR2 SDRAM Controller Input AC Timing

ADSP-21469

DDR2 SDRAM Write Cycle Timing

Table 29. DDR2 SDRAM Write Cycle Timing, $V_{DD-DDR2}$ Nominal 1.8 V

Parameter	200 MHz ¹		225 MHz ¹		Unit
	Min	Max	Min	Max	
<i>Switching Characteristics</i>					
t_{CK}	Clock Cycle Time		4.22	4.8	ns
t_{CH}	Minimum Clock Pulse Width		2.05	2.75	ns
t_{CL}	Maximum Clock Pulse Width		2.05	2.75	ns
t_{DQSS}^2	DQS Latching Rising Transitions to Associated Clock Edges		-0.45	0.45	ns
t_{DS}	Last Data Valid to DQS Delay		0.5	0.6	ns
t_{DH}	DQS to First Data Invalid Delay		0.55	0.65	ns
t_{DSS}	DQS Falling Edge to Clock Setup Time		1.65	1.95	ns
t_{DSH}	DQS Falling Edge Hold Time From CK		1.8	2.05	ns
t_{DQSH}	DQS Input HIGH Pulse Width		1.65	2.05	ns
t_{DQSL}	DQS Input LOW Pulse Width		1.65	2.0	ns
t_{WPRE}	Write Preamble		0.8	0.8	t_{CK}
t_{WPST}	Write Postamble		0.5	0.5	t_{CK}
t_{AS}	Control/address Maximum Delay From DDCK Rise		1.65	1.85	ns
t_{AH}	Control/Address Minimum Delay From DDCK Rise		0.9	1.0	ns

¹ In order to ensure proper operation of the DDR2, all the DDR2 guidelines have to be strictly followed (see Engineer-to-Engineer Note No: EE-349).

² Write command to first DQS delay = $WL \times t_{CK} + t_{DQSS}$.

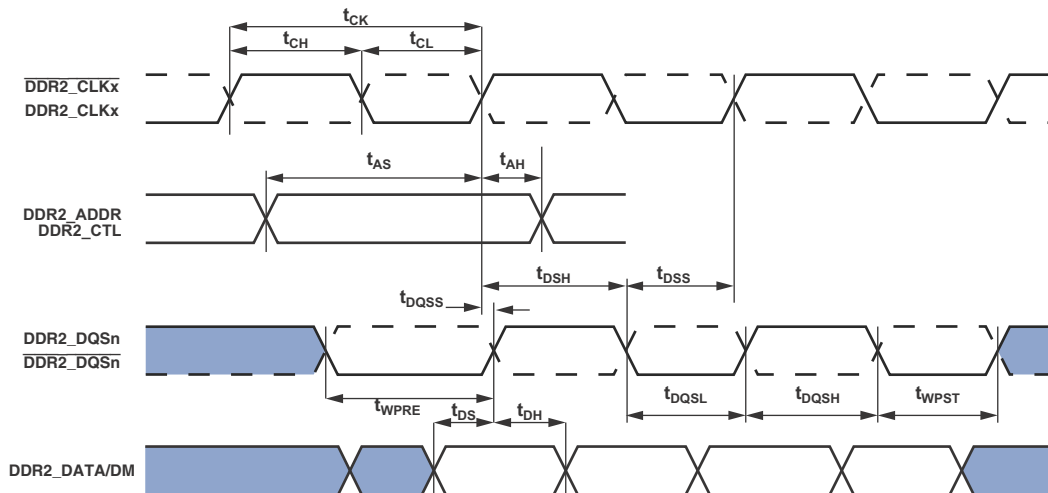

Figure 19. DDR2 SDRAM Controller Output AC Timing

AMI Read

Use these specifications for asynchronous interfacing to memories. Note that timing for AMI_ACK, AMI_DATA, AMI_RD, AMI_WR, and strobe timing parameters only apply to asynchronous access mode.

Table 30. Memory Read

Parameter	Min	Max	Unit
<i>Timing Requirements</i>			
t _{DAD} Address, Selects Delay to Data Valid ^{1,2}		W + t _{DDR2_CLK} - 5.4	ns
t _{DRLD} $\overline{\text{AMI_RD}}$ Low to Data Valid ¹		W - 3.2	ns
t _{SDS} Data Setup to $\overline{\text{AMI_RD}}$ High	2.5		ns
t _{HDRH} Data Hold from $\overline{\text{AMI_RD}}$ High ^{3, 4}	0		ns
t _{DAAK} AMI_ACK Delay from Address, Selects ^{2,5}		t _{DDR2_CLK} - 9.5 + W	ns
t _{DSAK} AMI_ACK Delay from $\overline{\text{AMI_RD}}$ Low ⁴		W - 7.0	ns
<i>Switching Characteristics</i>			
t _{DRHA} Address Selects Hold After $\overline{\text{AMI_RD}}$ High	RH + 0.20		ns
t _{DARL} Address Selects to $\overline{\text{AMI_RD}}$ Low ²	t _{DDR2_CLK} - 3.8		ns
t _{RW} $\overline{\text{AMI_RD}}$ Pulse Width	W - 1.4		ns
t _{RWR} $\overline{\text{AMI_RD}}$ High to $\overline{\text{AMI_RD}}$ Low	HI + t _{DDR2_CLK} - 1		ns

W = (number of wait states specified in AMICTLx register) × t_{DDR2_CLK}

RHC = (number of Read Hold Cycles specified in AMICTLx register) × t_{DDR2_CLK}

Where PREDIS = 0

HI = RHC: Read to Read from same bank

HI = RHC + IC: Read to Read from different bank

HI = RHC + Max(IC, (4 × t_{DDR2_CLK})): Read to Write from same or different bank

Where PREDIS = 1

HI = RHC + Max(IC, (4 × t_{DDR2_CLK})): Read to Write from same or different bank

HI = RHC + (3 × t_{DDR2_CLK}): Read to Read from same bank

HI = RHC + Max(IC, (3 × t_{DDR2_CLK})): Read to Read from different bank

IC = (number of idle cycles specified in AMICTLx register) × t_{DDR2_CLK}

H = (number of hold cycles specified in AMICTLx register) × t_{DDR2_CLK}

¹Data delay/setup: System must meet t_{DAD}, t_{DRLD}, or t_{SDS}.

²The falling edge of $\overline{\text{AMI_MSx}}$, is referenced.

³Note that timing for AMI_ACK, AMI_DATA, $\overline{\text{AMI_RD}}$, $\overline{\text{AMI_WR}}$, and strobe timing parameters only apply to asynchronous access mode.

⁴Data hold: User must meet t_{HDRH} in asynchronous access mode. See [Test Conditions on Page 58](#) for the calculation of hold times given capacitive and dc loads.

⁵AMI_ACK delay/setup: User must meet t_{DAAK}, or t_{DSAK}, for deassertion of AMI_ACK (low).

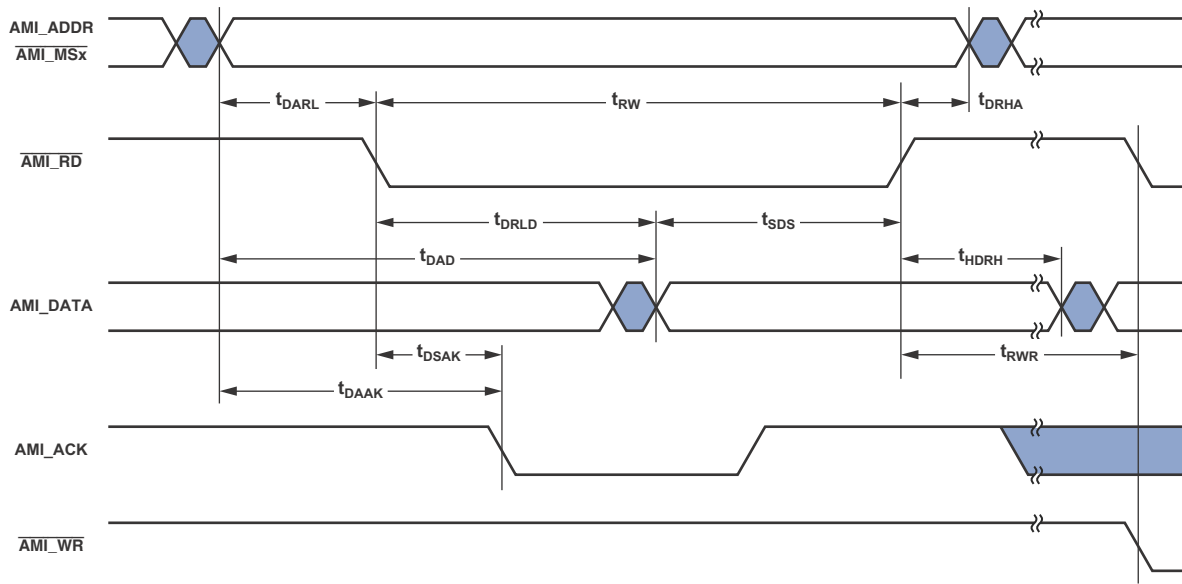

Figure 20. AMI Read

AMI Write

Use these specifications for asynchronous interfacing to memories. Note that timing for AMI_ACK, AMI_DATA, AMI_RD, AMI_WR, and strobe timing parameters only apply to asynchronous access mode.

Table 31. Memory Write

Parameter	Min	Max	Unit
<i>Timing Requirements</i>			
t _{DAAK} AMI_ACK Delay from Address, Selects ^{1,2}		t _{DDR2_CLK} - 9.7 + W	ns
t _{DSAK} AMI_ACK Delay from $\overline{\text{AMI_WR}}$ Low ^{1,3}		W - 6	ns
<i>Switching Characteristics</i>			
t _{DAWH} Address, Selects to $\overline{\text{AMI_WR}}$ Deasserted ²	t _{DDR2_CLK} - 3.1 + W		ns
t _{DAWL} Address, Selects to $\overline{\text{AMI_WR}}$ Low ²	t _{DDR2_CLK} - 3		ns
t _{WW} $\overline{\text{AMI_WR}}$ Pulse Width	W - 1.3		ns
t _{DDWH} Data Setup Before $\overline{\text{AMI_WR}}$ High	t _{DDR2_CLK} - 3.0 + W		ns
t _{DWHA} Address Hold After $\overline{\text{AMI_WR}}$ Deasserted	H + 0.15		ns
t _{DWHD} Data Hold After $\overline{\text{AMI_WR}}$ Deasserted	H		ns
t _{DATRWH} Data Disable After $\overline{\text{AMI_WR}}$ Deasserted ⁴	t _{DDR2_CLK} - 1.37 + H	t _{DDR2_CLK} + 4.9 + H	ns
t _{WWR} $\overline{\text{AMI_WR}}$ High to $\overline{\text{AMI_WR}}$ Low ⁵	t _{DDR2_CLK} - 1.5 + H		ns
t _{DDWR} Data Disable Before $\overline{\text{AMI_RD}}$ Low	2t _{DDR2_CLK} - 6		ns
t _{WDE} $\overline{\text{AMI_WR}}$ Low to Data Enabled	t _{DDR2_CLK} - 3.5		ns

W = (number of wait states specified in AMICTLx register) × t_{SDDR2_CLK} H = (number of hold cycles specified in AMICTLx register) × t_{DDR2_CLK}

¹ AMI_ACK delay/setup: System must meet t_{DAAK}, or t_{DSAK}, for deassertion of AMI_ACK (low).

² The falling edge of $\overline{\text{AMI_MSx}}$ is referenced.

³ Note that timing for AMI_ACK, AMI_DATA, $\overline{\text{AMI_RD}}$, $\overline{\text{AMI_WR}}$, and strobe timing parameters only applies to asynchronous access mode.

⁴ See Test Conditions on Page 58 for calculation of hold times given capacitive and dc loads.

⁵ For Write to Write: t_{DDR2_CLK} + H, for both same bank and different bank. For Write to Read: (3 × t_{DDR2_CLK}) + H, for the same bank and different banks.

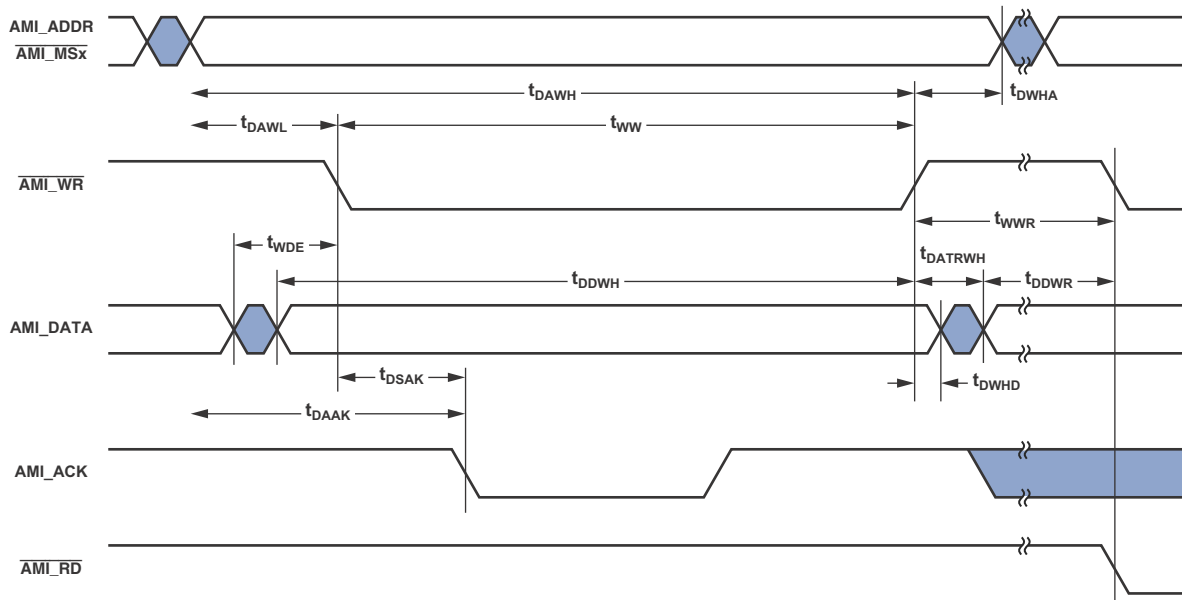

Figure 21. AMI Write

ADSP-21469

Link Ports

Calculation of link receiver data setup and hold relative to link clock is required to determine the maximum allowable skew that can be introduced in the transmission path length difference between LDATA and LCLK. Setup skew is the maximum

delay that can be introduced in LDATA relative to LCLK: (setup skew = $t_{LCLKTWH \text{ min}} - t_{DLDC} - t_{SLDCL}$). Hold skew is the maximum delay that can be introduced in LCLK relative to LDATA: (hold skew = $t_{LCLKTWH \text{ min}} - t_{HLDCH} - t_{HLDCL}$).

Table 32. Link Ports—Receive

Parameter	Min	Max	Unit
<i>Timing Requirements</i>			
t_{SLDCL} Data Setup Before LCLK Low	0.5		ns
t_{HLDCL} Data Hold After LCLK Low	1.5		ns
t_{LCLKIW} LCLK Period	t_{LCLK} (6 ns)		ns
$t_{LCLKRWL}$ LCLK Width Low	2.6		ns
$t_{LCLKRWH}$ LCLK Width High	2.6		ns
<i>Switching Characteristics</i>			
t_{DLALC} LACK Low Delay After LCLK Low ¹	5	12	ns

¹LACK goes low with t_{DLALC} relative to rise of LCLK after first byte, but does not go low if the receiver's link buffer is not about to fill.

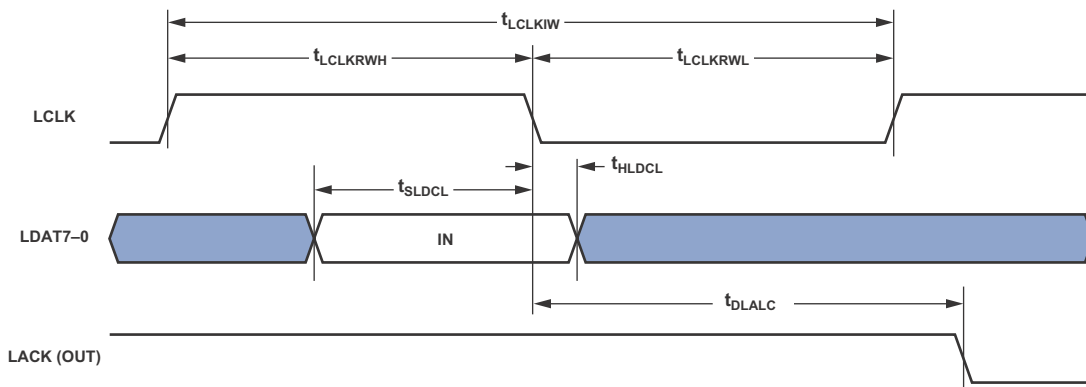
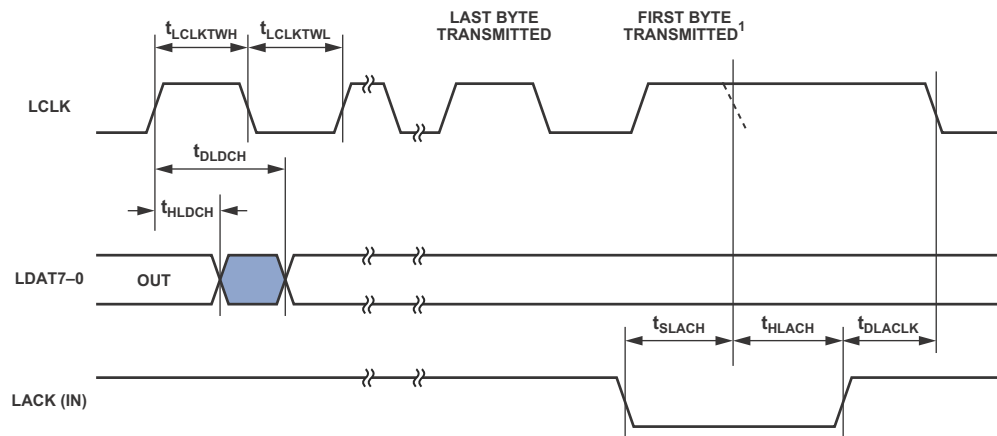

Figure 22. Link Ports—Receive

Table 33. Link Ports—Transmit

Parameter		Min	Max	Unit
<i>Timing Requirements</i>				
t_{SLACH}	LACK Setup Before LCLK Low	8.5		ns
t_{HLACH}	LACK Hold After LCLK Low	0		ns
<i>Switching Characteristics</i>				
t_{DLCH}	Data Delay After LCLK High		1	ns
t_{HLDCH}	Data Hold After LCLK High	-1		ns
$t_{LCLKTWL}$	LCLK Width Low	$0.5 \times t_{LCLK} - 0.4$	$0.6 \times t_{LCLK} + 0.4^1$	ns
$t_{LCLKTWH}$	LCLK Width High	$0.4 \times t_{LCLK} - 0.4^1$	$0.5 \times t_{LCLK} + 0.4$	ns
t_{DLACK}	LCLK Low Delay After LACK High	$t_{LCLK} - 2$	$t_{LCLK} + 8$	ns

¹For 1:2.5 ratio. For other ratios this specification is $0.5 \times t_{LCLK} - 1$.



NOTES

The t_{SLACH} and t_{HLACH} specifications apply only to the LACK falling edge. If these specifications are met, LCLK would extend and the dotted LCLK falling edge would not occur as shown. The position of the dotted falling edge can be calculated using the $t_{LCLKTWH}$ specification. $t_{LCLKTWH}$ Min should be used for t_{SLACH} and $t_{LCLKTWH}$ Max for t_{HLACH} .

Figure 23. Link Ports—Transmit

ADSP-21469

Serial Ports

In slave transmitter mode and master receiver mode the maximum serial port frequency is $f_{PCLK}/8$. To determine whether communication is possible between two devices at clock speed n , the following specifications must be confirmed: 1) frame sync delay and frame sync setup and hold, 2) data delay and data setup and hold, and 3) serial clock (SCLK) width.

Serial port signals are routed to the DAI_P20–1 pins using the SRU. Therefore, the timing specifications provided below are valid at the DAI_P20–1 pins. In [Figure 24](#) either the rising edge or the falling edge of SCLK (external or internal) can be used as the active sampling edge.

Table 34. Serial Ports—External Clock

Parameter	Min	Max	Unit
<i>Timing Requirements</i>			
t_{SFSE}^1 Frame Sync Setup Before SCLK (Externally Generated Frame Sync in either Transmit or Receive Mode)	2.5		ns
t_{HFSE}^1 Frame Sync Hold After SCLK (Externally Generated Frame Sync in either Transmit or Receive Mode)	2.5		ns
t_{SDRE}^1 Receive Data Setup Before Receive SCLK	1.9		ns
t_{HDRE}^1 Receive Data Hold After SCLK	2.5		ns
t_{SCLKW} SCLK Width	$(t_{PCLK} \times 4) \div 2 - 0.5$		ns
t_{SCLK} SCLK Period	$t_{PCLK} \times 4$		ns
<i>Switching Characteristics</i>			
t_{DFSE}^2 Frame Sync Delay After SCLK (Internally Generated Frame Sync in either Transmit or Receive Mode)		10.25	ns
t_{HOFSE}^2 Frame Sync Hold After SCLK (Internally Generated Frame Sync in either Transmit or Receive Mode)	2		ns
t_{DDTE}^2 Transmit Data Delay After Transmit SCLK		8.5	ns
t_{HDTE}^2 Transmit Data Hold After Transmit SCLK	2		ns

¹Referenced to sample edge.

²Referenced to drive edge.

Table 35. Serial Ports—Internal Clock

Parameter	Min	Max	Unit
<i>Timing Requirements</i>			
t_{SFSI}^1 Frame Sync Setup Before SCLK (Externally Generated Frame Sync in either Transmit or Receive Mode)	7		ns
t_{HFSI}^1 Frame Sync Hold After SCLK (Externally Generated Frame Sync in either Transmit or Receive Mode)	2.5		ns
t_{SDRI}^1 Receive Data Setup Before SCLK	7		ns
t_{HDRI}^1 Receive Data Hold After SCLK	2.5		ns
<i>Switching Characteristics</i>			
t_{DFSI}^2 Frame Sync Delay After SCLK (Internally Generated Frame Sync in Transmit Mode)		4	ns
t_{HOFSI}^2 Frame Sync Hold After SCLK (Internally Generated Frame Sync in Transmit Mode)	-1.0		ns
t_{DFSIR}^2 Frame Sync Delay After SCLK (Internally Generated Frame Sync in Receive Mode)		9.75	ns
$t_{HOF SIR}^2$ Frame Sync Hold After SCLK (Internally Generated Frame Sync in Receive Mode)	-1.0		ns
t_{DDTI}^2 Transmit Data Delay After SCLK		3.25	ns
$t_{HD TI}^2$ Transmit Data Hold After SCLK	-1.25		ns
t_{SCLKW} Transmit or Receive SCLK Width	$2 \times t_{PCLK} - 1.5$	$2 \times t_{PCLK} + 1.5$	ns

¹Referenced to the sample edge.

²Referenced to drive edge.

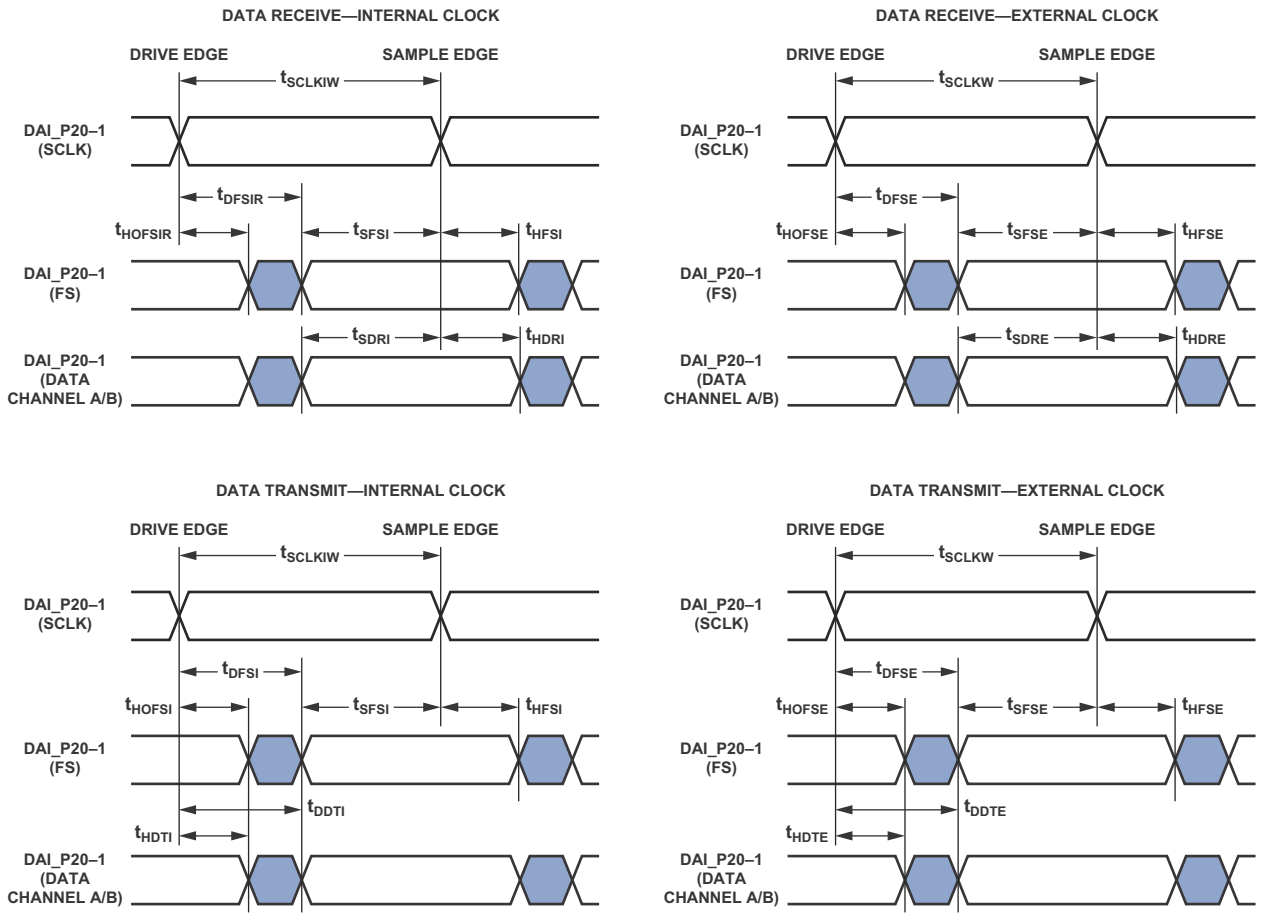

Figure 24. Serial Ports

ADSP-21469

Table 36. Serial Ports—Enable and Three-State

Parameter		Min	Max	Unit
<i>Switching Characteristics</i>				
t_{DDTEN}^1	Data Enable from External Transmit SCLK	2		ns
t_{DDTE}^1	Data Disable from External Transmit SCLK		11.5	ns
t_{DDTIN}^1	Data Enable from Internal Transmit SCLK	-1		ns

¹Referenced to drive edge.

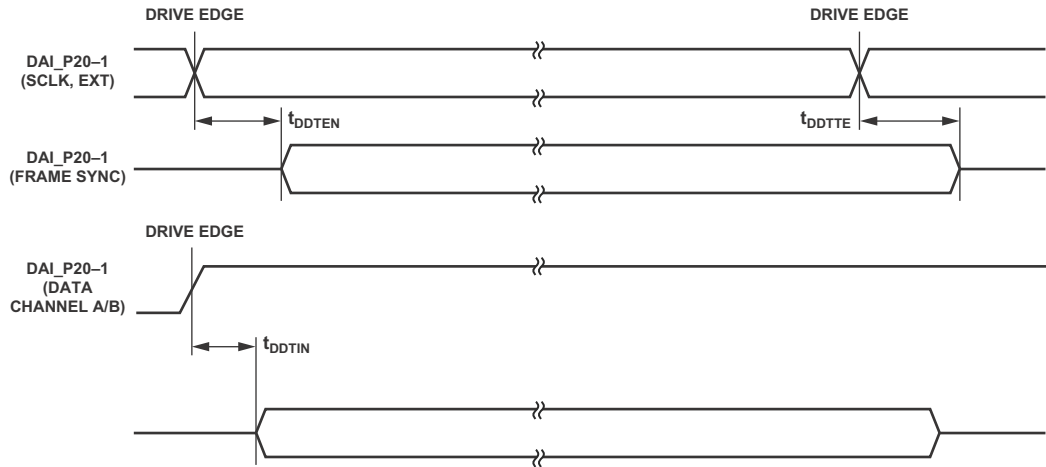

Figure 25. Serial Ports—Enable and Three-State

The SPORTx_TDV_O output signal (routing unit) becomes active in SPORT multichannel mode. During transmit slots (enabled with active channel selection registers) the SPORTx_TDV_O is asserted for communication with external devices.

Table 37. Serial Ports—TDV (Transmit Data Valid)

Parameter	Min	Max	Unit
<i>Switching Characteristics¹</i>			
t_{DRDVEN} Data-Valid Enable Delay from Drive Edge of External Clock	3		ns
t_{DFDVEN} Data-Valid Disable Delay from Drive Edge of External Clock		8	ns
t_{DRDVIN} Data-Valid Enable Delay from Drive Edge of Internal Clock	-0.1		ns
t_{DFDVIN} Data-Valid Disable Delay from Drive Edge of Internal Clock		2	ns

¹Referenced to drive edge.

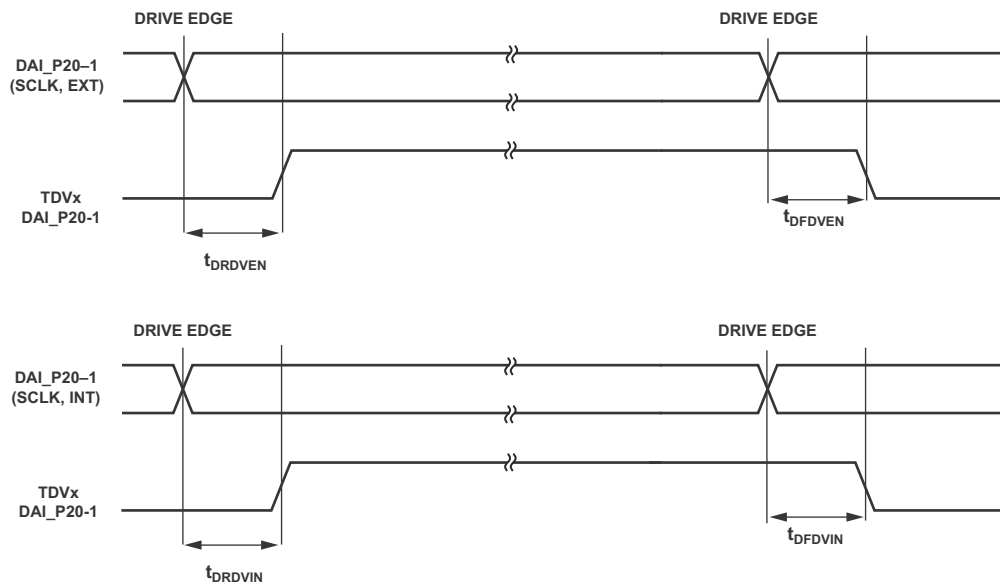

Figure 26. Serial Ports—Transmit Data Valid Internal and External Clock

Table 38. Serial Ports—External Late Frame Sync

Parameter	Min	Max	Unit
<i>Switching Characteristics</i>			
$t_{DDTLFSE}^1$ Data Delay from Late External Transmit Frame Sync or External Receive Frame Sync with MCE = 1, MFD = 0		7.75	ns
$t_{DDTENFS}^1$ Data Enable for MCE = 1, MFD = 0	0.5		ns

¹The $t_{DDTLFSE}$ and $t_{DDTENFS}$ parameters apply to left-justified as well as DSP serial mode, and MCE = 1, MFD = 0.

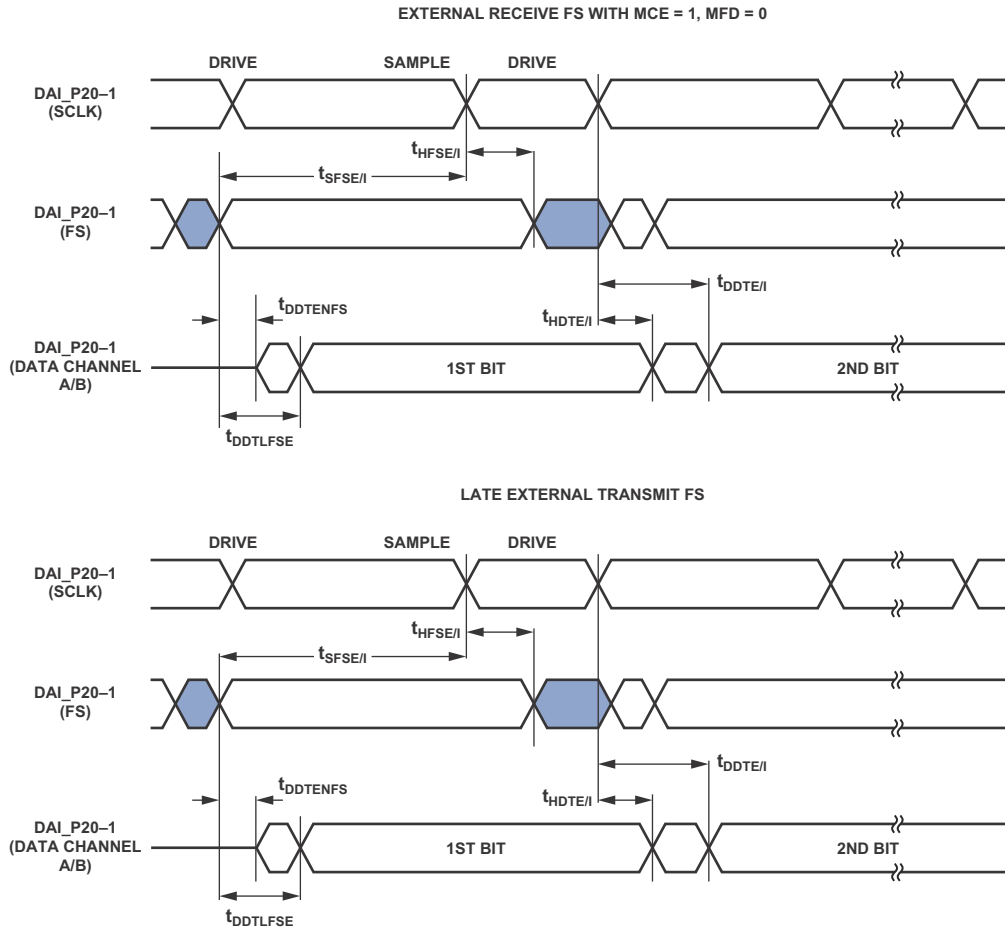

Figure 27. External Late Frame Sync

Input Data Port (IDP)

The timing requirements for the IDP are given in Table 39. IDP signals are routed to the DAI_P20-1 pins using the SRU. Therefore, the timing specifications provided below are valid at the DAI_P20-1 pins.

Table 39. Input Data Port (IDP)

Parameter	Min	Max	Unit
<i>Timing Requirements</i>			
t_{SIFS}^1 Frame Sync Setup Before Serial Clock Rising Edge	3.8		ns
t_{SIHFS}^1 Frame Sync Hold After Serial Clock Rising Edge	2.5		ns
t_{SISD}^1 Data Setup Before Serial Clock Rising Edge	2.5		ns
t_{SIHD}^1 Data Hold After Serial Clock Rising Edge	2.5		ns
$t_{IDPCLKW}$ Clock Width	$(t_{PCLK} \times 4) \div 2 - 1$		ns
t_{IDPCLK} Clock Period	$t_{PCLK} \times 4$		ns

¹ The serial clock, data, and frame sync signals can come from any of the DAI pins. The serial clock and frame sync signals can also come via PCG or SPORTs. PCG's input can be either CLKIN or any of the DAI pins.

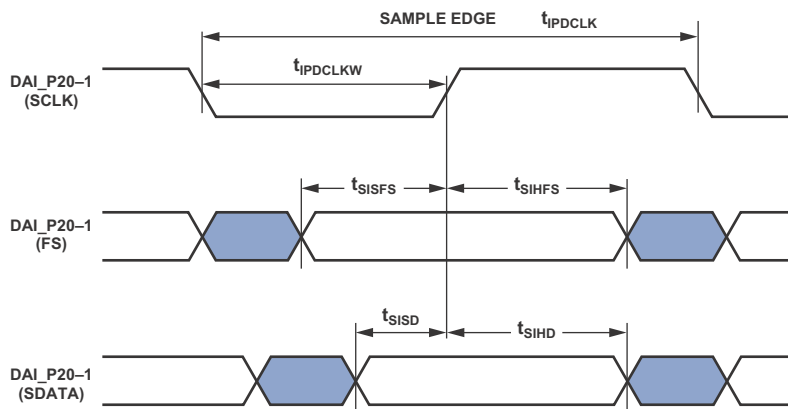

Figure 28. IDP Master Timing

ADSP-21469

Parallel Data Acquisition Port (PDAP)

The timing requirements for the PDAP are provided in [Table 40](#). PDAP is the parallel mode operation of channel 0 of the IDP. For details on the operation of the PDAP, see the

PDAP chapter of the *ADSP-214xx SHARC Processor Hardware Reference*. Note that the 20 bits of external PDAP data can be provided through the AMI_ADDR23–4 pins or over the DAI pins.

Table 40. Parallel Data Acquisition Port (PDAP)

Parameter	Min	Max	Unit
<i>Timing Requirements</i>			
t_{SPHOLD}^1	PDAP_HOLD Setup Before PDAP_CLK Sample Edge	2.5	ns
t_{HPHOLD}^1	PDAP_HOLD Hold After PDAP_CLK Sample Edge	2.5	ns
t_{PDS}^1	PDAP_DAT Setup Before Serial Clock PDAP_CLK Sample Edge	3.85	ns
t_{PDHD}^1	PDAP_DAT Hold After Serial Clock PDAP_CLK Sample Edge	2.5	ns
t_{PDCLKW}	Clock Width	$(t_{PCLK} \times 4) \div 2 - 3$	ns
t_{PDCLK}	Clock Period	$t_{PCLK} \times 4$	ns
<i>Switching Characteristics</i>			
t_{PDHLDD}	Delay of PDAP Strobe After Last PDAP_CLK Capture Edge for a Word	$2 \times t_{PCLK} + 3$	ns
t_{PDSTRB}	PDAP Strobe Pulse Width	$2 \times t_{PCLK} - 1$	ns

¹ Data source pins are AMI_ADDR23–4 or DAI pins. Source pins for serial clock and frame sync are 1) AMI_ADDR3–2 pins, 2) DAI pins.

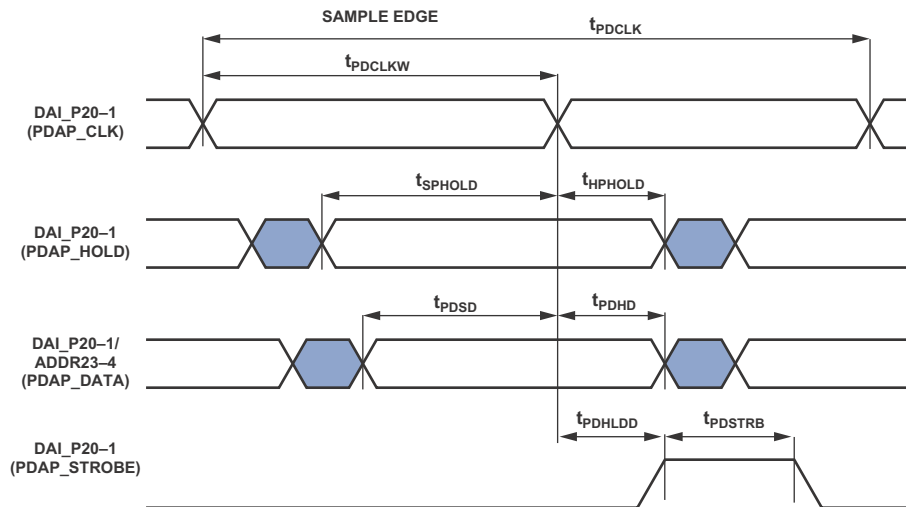

Figure 29. PDAP Timing

Sample Rate Converter—Serial Input Port

The ASRC input signals are routed from the DAI_P20–1 pins using the SRU. Therefore, the timing specifications provided in [Table 41](#) are valid at the DAI_P20–1 pins.

Table 41. ASRC, Serial Input Port

Parameter	Min	Max	Unit
<i>Timing Requirements</i>			
t_{SRCFS}^1 Frame Sync Setup Before Serial Clock Rising Edge	4		ns
t_{SRCHFS}^1 Frame Sync Hold After Serial Clock Rising Edge	5.5		ns
t_{SRCSD}^1 Data Setup Before Serial Clock Rising Edge	4		ns
t_{SRCHD}^1 Data Hold After Serial Clock Rising Edge	5.5		ns
$t_{SRCCLKW}$ Clock Width	$(t_{PCLK} \times 4) \div 2 - 1$		ns
t_{SRCCLK} Clock Period	$t_{PCLK} \times 4$		ns

¹ The serial clock, data, and frame sync signals can come from any of the DAI pins. The serial clock and frame sync signals can also come via PCG or SPORTs. PCG's input can be either CLKIN or any of the DAI pins.

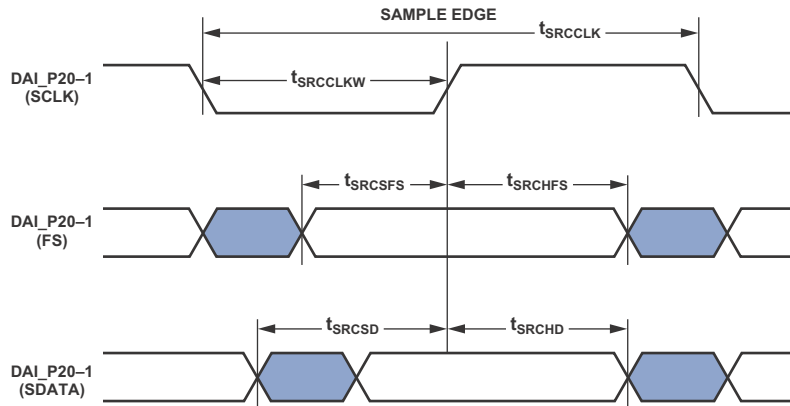

Figure 30. ASRC Serial Input Port Timing

Sample Rate Converter—Serial Output Port

For the serial output port, the frame sync is an input and it should meet setup and hold times with regard to the serial clock on the output port. The serial data output has a hold time and

delay specification with regard to serial clock. Note that the serial clock rising edge is the sampling edge, and the falling edge is the drive edge.

Table 42. ASRC, Serial Output Port

Parameter	Min	Max	Unit
<i>Timing Requirements</i>			
t_{SRCFS}^1 Frame Sync Setup Before Serial Clock Rising Edge	4		ns
t_{SRCHFS}^1 Frame Sync Hold After Serial Clock Rising Edge	5.5		ns
t_{SRCCLKW} Clock Width	$(t_{\text{PCLK}} \times 4) \div 2 - 1$		ns
t_{SRCCLK} Clock Period	$t_{\text{PCLK}} \times 4$		ns
<i>Switching Characteristics</i>			
t_{SRCTDD}^1 Transmit Data Delay After Serial Clock Falling Edge		9.9	ns
t_{SRCTDH}^1 Transmit Data Hold After Serial Clock Falling Edge	1		ns

¹ The serial clock, data, and frame sync signals can come from any of the DAI pins. The serial clock and frame sync signals can also come via PCG or SPORTs. PCG's input can be either CLKIN or any of the DAI pins.

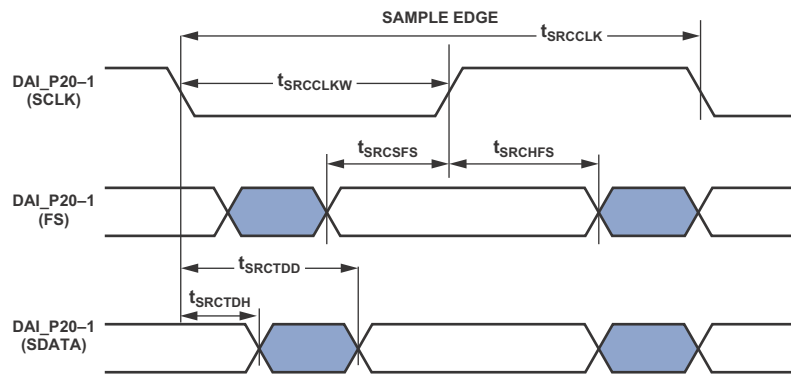

Figure 31. ASRC Serial Output Port Timing

Pulse-Width Modulation (PWM) Generators

The following timing specifications apply when the AML_ADDR23–8 pins are configured as PWM.

Table 43. Pulse-Width Modulation (PWM) Timing

Parameter	Min	Max	Unit
<i>Switching Characteristics</i>			
t_{PWW} PWM Output Pulse Width	$t_{PCLK} - 2$	$(2^{16} - 2) \times t_{PCLK} - 2$	ns
t_{PWMP} PWM Output Period	$2 \times t_{PCLK} - 1.5$	$(2^{16} - 1) \times t_{PCLK} - 1.5$	ns

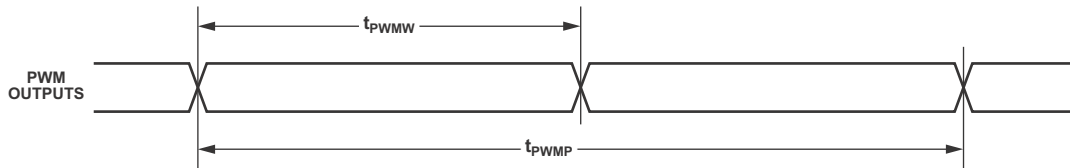

Figure 32. PWM Timing

S/PDIF Transmitter

Serial data input to the S/PDIF transmitter can be formatted as left-justified, I²S, or right-justified with word widths of 16, 18, 20, or 24 bits. The following sections provide timing for the transmitter.

S/PDIF Transmitter-Serial Input Waveforms

Figure 33 shows the right-justified mode. LRCLK is high for the left channel and low for the right channel. Data is valid on the rising edge of serial clock. The MSB is delayed minimum in 24-bit output mode or maximum in 16-bit output mode from an LRCLK transition, so that when there are 64 serial clock periods per LRCLK period, the LSB of the data will be right-justified to the next LRCLK transition.

Figure 34 shows the default I²S-justified mode. LRCLK is low for the left channel and HI for the right channel. Data is valid on the rising edge of serial clock. The MSB is left-justified to an LRCLK transition but with a delay.

Figure 35 shows the left-justified mode. LRCLK is high for the left channel and LO for the right channel. Data is valid on the rising edge of serial clock. The MSB is left-justified to an LRCLK transition with no delay.

Table 44. S/PDIF Transmitter Right-Justified Mode

Parameter	Nominal	Unit
<i>Timing Requirement</i>		
t_{RJD}		
LRCLK to MSB Delay in Right-Justified Mode		
16-Bit Word Mode	16	SCLK
18-Bit Word Mode	14	SCLK
20-Bit Word Mode	12	SCLK
24-Bit Word Mode	8	SCLK

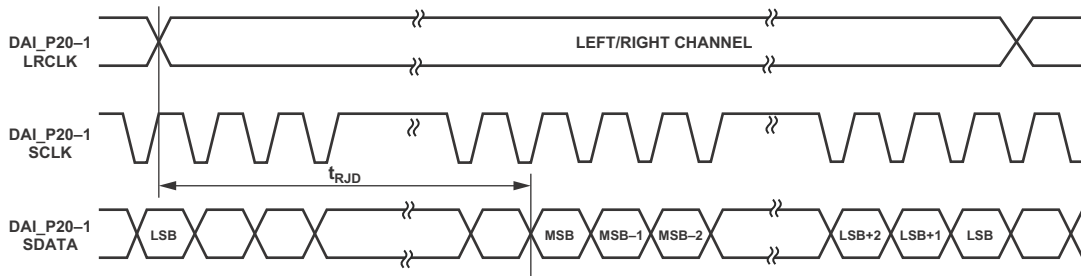

Figure 33. Right-Justified Mode

Table 45. S/PDIF Transmitter I²S Mode

Parameter	Nominal	Unit
<i>Timing Requirement</i>		
t_{2SD}		
LRCLK to MSB Delay in I ² S Mode	1	SCLK

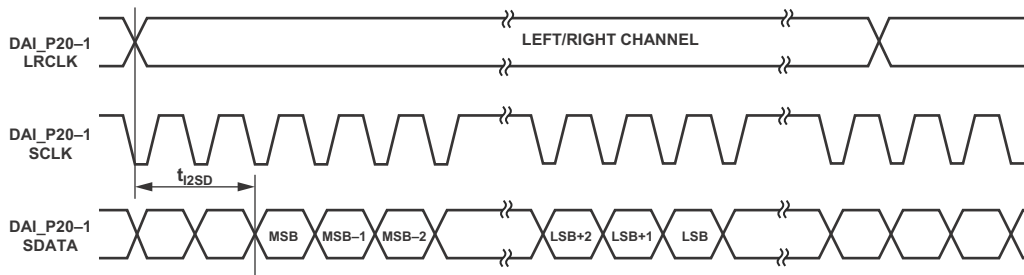

Figure 34. I²S-Justified Mode

Table 46. S/PDIF Transmitter Left-Justified Mode

Parameter	Nominal	Unit
<i>Timing Requirement</i>		
t_{LJD} LRCLK to MSB Delay in Left-Justified Mode	0	SCLK

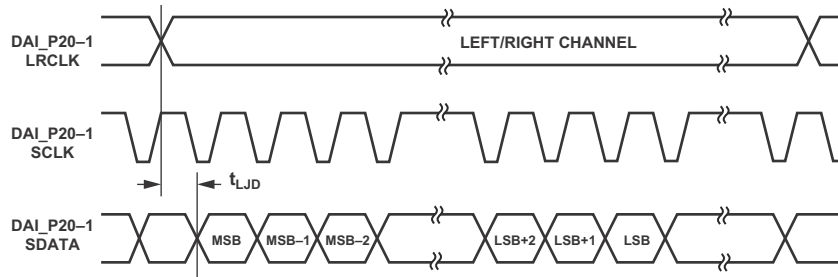

Figure 35. Left-Justified Mode

ADSP-21469

S/PDIF Transmitter Input Data Timing

The timing requirements for the S/PDIF transmitter are given in Table 47. Input signals are routed to the DAI_P20-1 pins using the SRU. Therefore, the timing specifications provided below are valid at the DAI_P20-1 pins.

Table 47. S/PDIF Transmitter Input Data Timing

Parameter	Min	Max	Unit
<i>Timing Requirements</i>			
t_{SISFS}^1	3		ns
t_{SIHFS}^1	3		ns
t_{SISD}^1	3		ns
t_{SIHD}^1	3		ns
$t_{SITXCLKW}$	9		ns
$t_{SITXCLK}$	20		ns
$t_{SISCLKW}$	36		ns
t_{SISCLK}	80		ns

¹The serial clock, data, and frame sync signals can come from any of the DAI pins. The serial clock and frame sync signals can also come via PCG or SPORTs. PCG's input can be either CLKIN or any of the DAI pins.

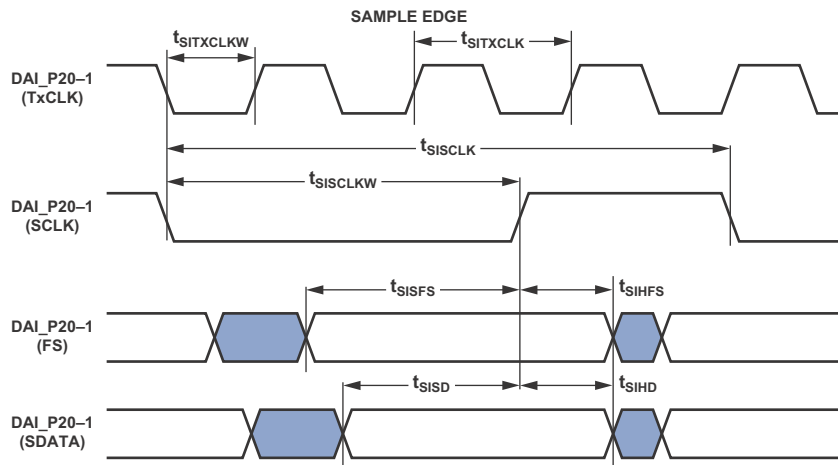

Figure 36. S/PDIF Transmitter Input Timing

Oversampling Clock (HFCLK) Switching Characteristics

The S/PDIF transmitter has an oversampling clock. This HFCLK input is divided down to generate the biphase clock.

Table 48. Oversampling Clock (HFCLK) Switching Characteristics

Parameter	Max	Unit
HFCLK Frequency for HFCLK = 384 × Frame Sync	Oversampling Ratio × Frame Sync ≤ 1/ $t_{SIHFCLK}$	MHz
HFCLK Frequency for HFCLK = 256 × Frame Sync	49.2	MHz
Frame Rate (Fs)	192.0	kHz

S/PDIF Receiver

The following section describes timing as it relates to the S/PDIF receiver.

Internal Digital PLL Mode

In the internal digital phase-locked loop mode the internal PLL (digital PLL) generates the $512 \times FS$ clock.

Table 49. S/PDIF Receiver Internal Digital PLL Mode Timing

Parameter		Min	Max	Unit
<i>Switching Characteristics</i>				
t_{DFSI}	LRCLK Delay After Serial Clock		5	ns
t_{HOFSI}	LRCLK Hold After Serial Clock	-2		ns
t_{DDTI}	Transmit Data Delay After Serial Clock		5	ns
t_{HDTI}	Transmit Data Hold After Serial Clock	-2		ns
t_{SCLKIW}^1	Transmit Serial Clock Width	$8 \times t_{PCLK} - 2$		ns

¹ Serial clock frequency is $64 \times$ Frame Sync, where FS = the frequency of LRCLK.

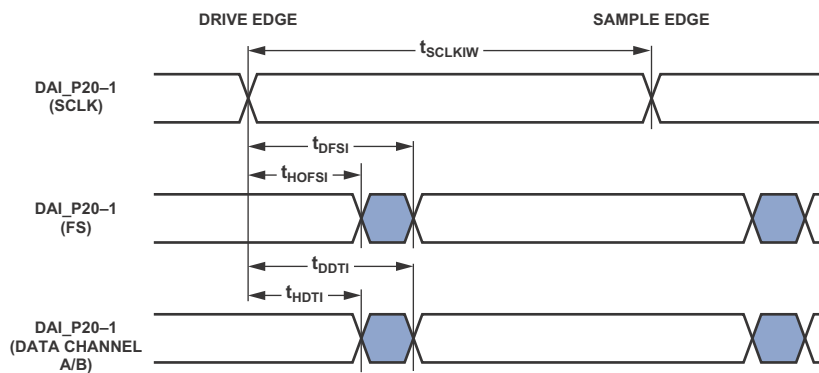

Figure 37. S/PDIF Receiver Internal Digital PLL Mode Timing

ADSP-21469

SPI Interface—Master

The ADSP-21469 contains two SPI ports. Both primary and secondary are available through DPI only. The timing provided in [Table 50](#) and [Table 51](#) applies to both.

Table 50. SPI Interface Protocol—Master Switching and Timing Specifications

Parameter		Min	Max	Unit
<i>Timing Requirements</i>				
t_{SSPIDM}	Data Input Valid to SPICLK Edge (Data Input Setup Time)	8.2		ns
t_{HSPIDM}	SPICLK Last Sampling Edge to Data Input Not Valid	2		ns
<i>Switching Characteristics</i>				
$t_{SPICLKM}$	Serial Clock Cycle	$8 \times t_{PCLK} - 2$		ns
t_{SPICHM}	Serial Clock High Period	$4 \times t_{PCLK} - 2$		ns
t_{SPICLM}	Serial Clock Low Period	$4 \times t_{PCLK} - 2$		ns
$t_{DDSPIDM}$	SPICLK Edge to Data Out Valid (Data Out Delay Time)		2.5	ns
$t_{HDSPIDM}$	SPICLK Edge to Data Out Not Valid (Data Out Hold Time)	$4 \times t_{PCLK} - 2$		ns
t_{SDSCIM}	DPI Pin (SPI Device Select) Low to First SPICLK Edge	$4 \times t_{PCLK} - 2$		ns
t_{HDSM}	Last SPICLK Edge to DPI Pin (SPI Device Select) High	$4 \times t_{PCLK} - 2$		ns
t_{SPITDM}	Sequential Transfer Delay	$4 \times t_{PCLK} - 1$		ns

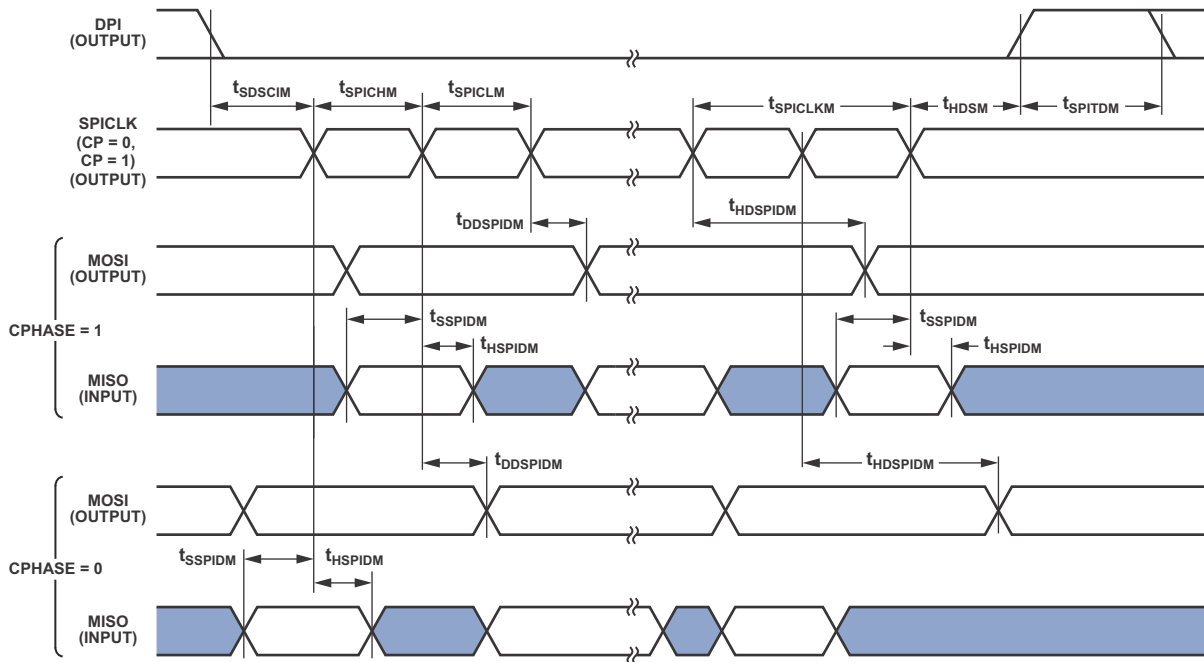

Figure 38. SPI Master Timing

SPI Interface—Slave

Table 51. SPI Interface Protocol—Slave Switching and Timing Specifications

Parameter		Min	Max	Unit
<i>Timing Requirements</i>				
t_{SPICLK}	Serial Clock Cycle	$4 \times t_{PCLK} - 2$		ns
t_{SPICHS}	Serial Clock High Period	$2 \times t_{PCLK} - 2$		ns
t_{SPICLS}	Serial Clock Low Period	$2 \times t_{PCLK} - 2$		ns
t_{SDSCO}	\overline{SPIDS} Assertion to First SPICLK Edge, CPHASE = 0 or CPHASE = 1	$2 \times t_{PCLK}$		ns
t_{HDS}	Last SPICLK Edge to \overline{SPIDS} Not Asserted, CPHASE = 0	$2 \times t_{PCLK}$		ns
t_{SSPIDS}	Data Input Valid to SPICLK Edge (Data Input Setup Time)	2		ns
t_{HSPIDS}	SPICLK Last Sampling Edge to Data Input Not Valid	2		ns
t_{SDPPW}	\overline{SPIDS} Deassertion Pulse Width (CPHASE = 0)	$2 \times t_{PCLK}$		ns
<i>Switching Characteristics</i>				
t_{DSOE}	\overline{SPIDS} Assertion to Data Out Active	0	6.8	ns
t_{DSOE}^1	\overline{SPIDS} Assertion to Data Out Active (SPI2)	0	8	ns
t_{DSDHI}	\overline{SPIDS} Deassertion to Data High Impedance	0	10.5	ns
t_{DSDHI}^1	\overline{SPIDS} Deassertion to Data High Impedance (SPI2)	0	10.5	ns
$t_{DDSPIDS}$	SPICLK Edge to Data Out Valid (Data Out Delay Time)		9.5	ns
$t_{HDSPIDS}$	SPICLK Edge to Data Out Not Valid (Data Out Hold Time)	$2 \times t_{PCLK}$		ns
t_{DSOV}	\overline{SPIDS} Assertion to Data Out Valid (CPHASE = 0)		$5 \times t_{PCLK}$	ns

¹The timing for these parameters applies when the SPI is routed through the signal routing unit. For more information, see the processor hardware reference, “Serial Peripheral Interface Port” chapter.

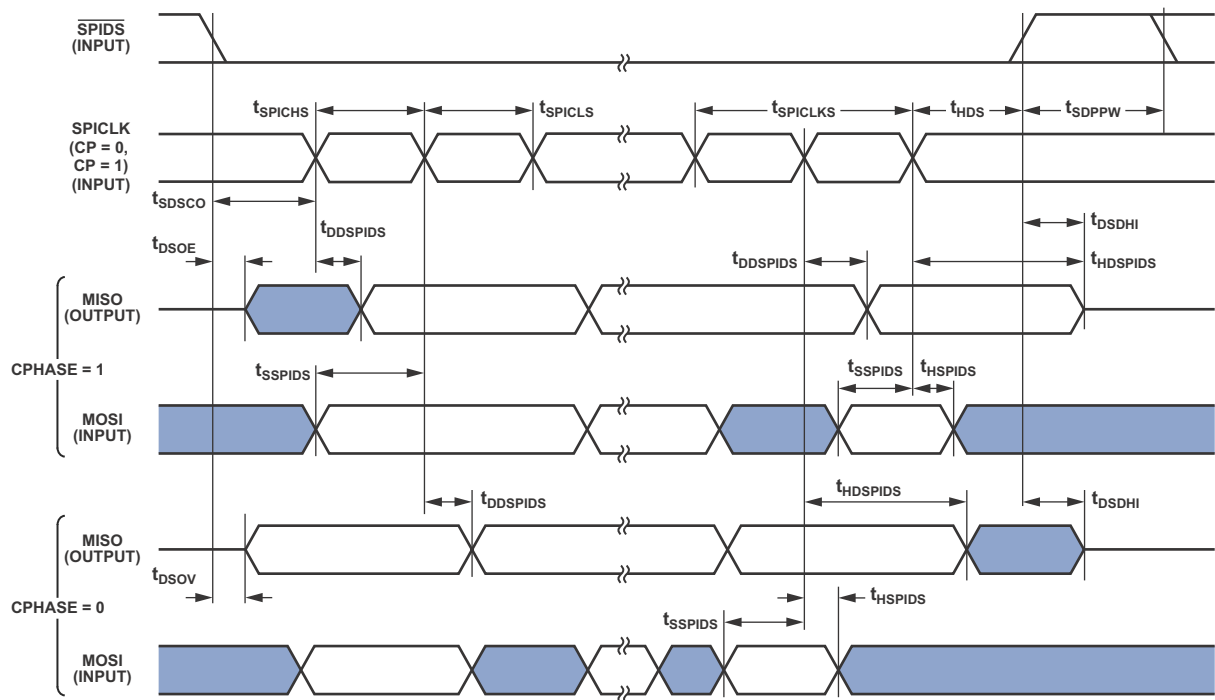

Figure 39. SPI Slave Timing

ADSP-21469

Media Local Bus

All the numbers given are applicable for all speed modes (1024 Fs, 512 Fs, and 256 Fs for 3-pin; 512 Fs and 256 Fs for 5-pin) unless otherwise specified. Please refer to MediaLB specification document rev 3.0 for more details.

Table 52. MLB Interface, 3-Pin Specifications

Parameter	Min	Typ	Max	Unit
<i>3-Pin Characteristics</i>				
t_{MLBCLK} MLB Clock Period		20.3		ns
	1024 Fs	40		ns
	512 Fs	81		ns
t_{MCKL} MLBCLK Low Time	6.1			ns
	14			ns
	30			ns
t_{MCKH} MLBCLK High Time	9.3			ns
	14			ns
	30			ns
t_{MCKR} MLBCLK Rise Time (V_{IL} to V_{IH})			1	ns
			3	ns
t_{MCKF} MLBCLK Fall Time (V_{IH} to V_{IL})			1	ns
			3	ns
t_{MPWV}^1 MLBCLK Pulse Width Variation			0.7	ns p-p
			2.0	ns p-p
t_{DSMCF} DAT/SIG Input Setup Time	1			ns
t_{DHMCF} DAT/SIG Input Hold Time	1			ns
t_{MCFDZ} DAT/SIG Output Time to Three-state	0		15	ns
t_{MCDRV} DAT/SIG Output Data Delay From MLBCLK Rising Edge			8	ns
t_{MDZH}^2 Bus Hold Time	2			ns
	4			ns
C_{MLB} DAT/SIG Pin Load			40	pf
			60	pf

¹ Pulse width variation is measured at 1.25 V by triggering on one edge of MLBCLK and measuring the spread on the other edge, measured in nanoseconds peak-to-peak (ns p-p).

² The board must be designed to ensure that the high impedance bus does not leave the logic state of the final driven bit for this time period. Therefore, coupling must be minimized while meeting the maximum capacitive load listed.

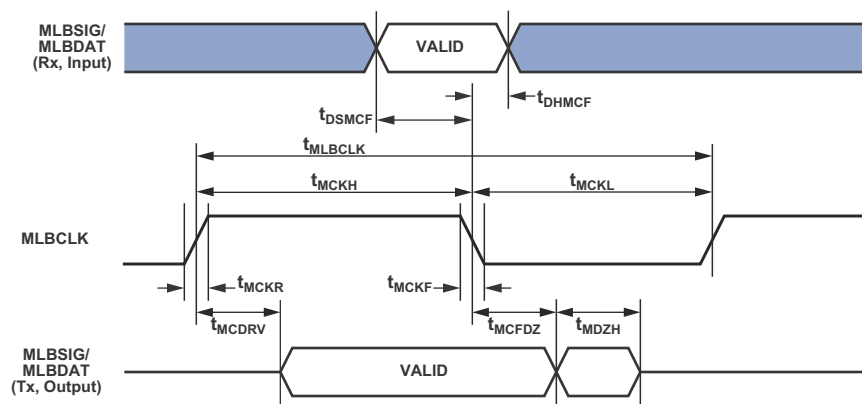

Figure 40. MLB Timing (3-Pin Interface)

Table 53. MLB Interface, 5-Pin Specifications

Parameter	Min	Typ	Max	Unit
<i>5-Pin Characteristics</i>				
t_{MLBCLK} MLB Clock Period		40		ns
512 Fs		81		ns
256 Fs				
t_{MCKL} MLBCLK Low Time	15			ns
512 Fs	30			ns
256 Fs				
t_{MCKH} MLBCLK High Time	15			ns
512 Fs	30			ns
256 Fs				
t_{MCKR} MLBCLK Rise Time (V_{IL} to V_{IH})			6	ns
t_{MCKF} MLBCLK Fall Time (V_{IH} to V_{IL})			6	ns
t_{MPWV}^1 MLBCLK Pulse Width Variation			2	ns p-p
t_{DSMCF}^2 DAT/SIG Input Setup Time	3			ns
t_{DHMcF} DAT/SIG Input Hold Time	5			ns
t_{MCDRV} DS/DO Output Data Delay From MLBCLK Rising Edge			8	ns
t_{MCRDL}^3 DO/SO Low From MLBCLK High				
512 Fs			10	ns
256 Fs			20	ns
C_{MLB} DS/DO Pin Load			40	pf

¹ Pulse width variation is measured at 1.25 V by triggering on one edge of MLBCLK and measuring the spread on the other edge, measured in nanoseconds peak-to-peak (ns p-p).

² Gate delays due to OR'ing logic on the pins must be accounted for.

³ When a node is not driving valid data onto the bus, the MLBSO and MLBDO output lines shall remain low. If the output lines can float at anytime, including while in reset, external pull-down resistors are required to keep the outputs from corrupting the MediaLB signal lines when not being driven.

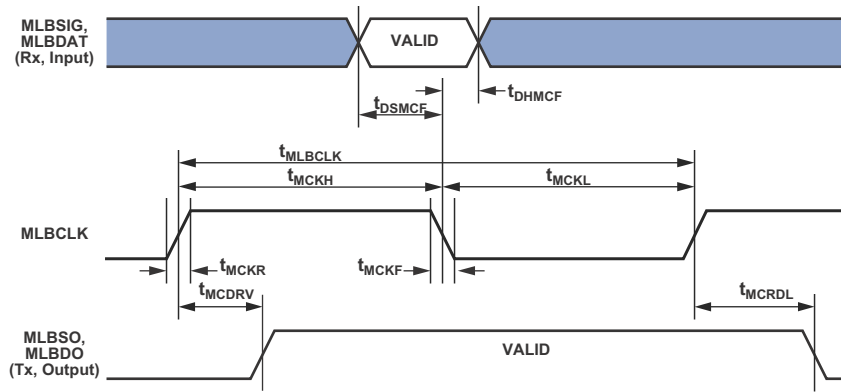

Figure 41. MLB Timing (5-Pin Interface)

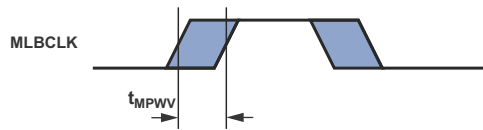

Figure 42. MLB 3-Pin and 5-Pin MLBCLK Pulse Width Variation Timing

Universal Asynchronous Receiver-Transmitter (UART) Ports—Receive and Transmit Timing

For information on the UART port receive and transmit operations, see the *ADSP-214xx SHARC Hardware Reference Manual*.

2-Wire Interface (TWI)—Receive and Transmit Timing

For information on the TWI receive and transmit operations, see the *ADSP-214xx SHARC Hardware Reference Manual*.

JTAG Test Access Port and Emulation

Table 54. JTAG Test Access Port and Emulation

Parameter	Min	Max	Unit
<i>Timing Requirements</i>			
t_{TCK} TCK Period	20		ns
t_{STAP} TDI, TMS Setup Before TCK High	5		ns
t_{HTAP} TDI, TMS Hold After TCK High	6		ns
t_{SSYS}^1 System Inputs Setup Before TCK High	7		ns
t_{HSYS}^1 System Inputs Hold After TCK High	18		ns
t_{TRSTW} \overline{TRST} Pulse Width	$4 \times t_{CK}$		ns
<i>Switching Characteristics</i>			
t_{DTDO} TDO Delay from TCK Low		10	ns
t_{DSYS}^2 System Outputs Delay After TCK Low		$t_{CK} \div 2 + 7$	ns

¹System Inputs = AMI_DATA, DDR2_DATA, CLKCFG1-0, BOOTCFG2-0 RESET, DAI, DPI, FLAG3-0.

²System Outputs = AMI_ADDR/DATA, DDR2_ADDR/DATA, AMI_CTRL, DDR2_CTRL, DAI, DPI, FLAG3-0, \overline{EMU} .

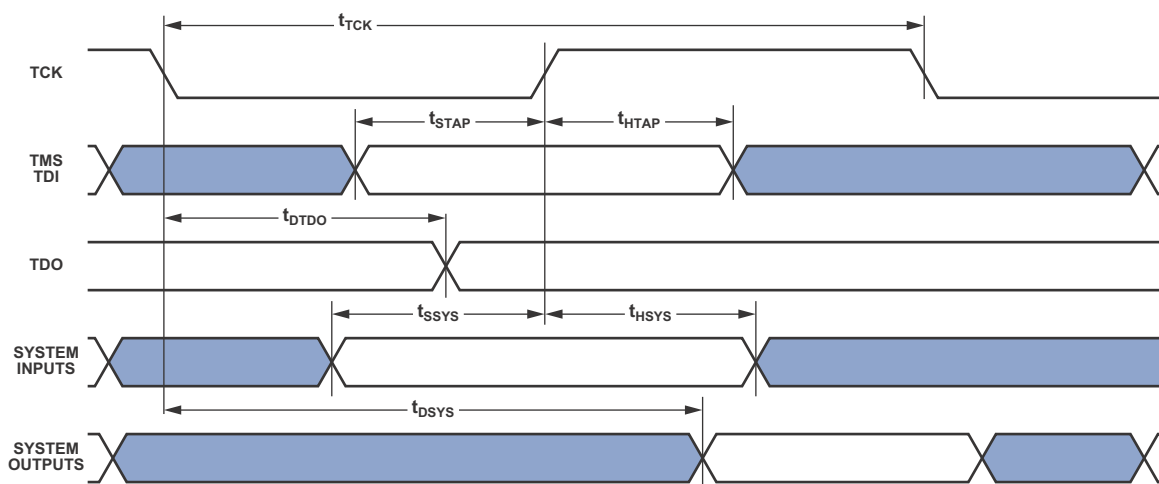

Figure 43. IEEE 1149.1 JTAG Test Access Port

ADSP-21469

TEST CONDITIONS

The ac signal specifications (timing parameters) appear in [Table 19 on Page 25](#) through [Table 54 on Page 57](#). These include output disable time, output enable time, and capacitive loading. The timing specifications for the SHARC apply for the voltage reference levels in [Figure 44](#).

Timing is measured on signals when they cross the V_{MEAS} level as described in [Figure 45](#). All delays (in nanoseconds) are measured between the point that the first signal reaches V_{MEAS} and the point that the second signal reaches V_{MEAS} . The value of V_{MEAS} is 1.5 V for non-DDR pins and 0.9 V for DDR pins.

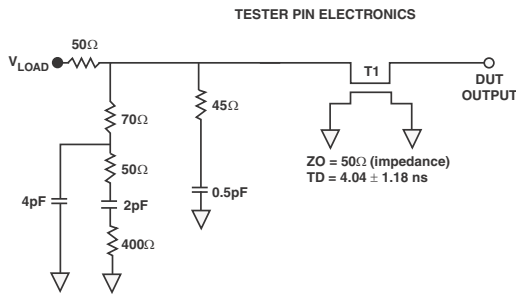

NOTES:
THE WORST-CASE TRANSMISSION LINE DELAY IS SHOWN AND CAN BE USED FOR THE OUTPUT TIMING ANALYSIS TO REFLECT THE TRANSMISSION LINE EFFECT AND MUST BE CONSIDERED. THE TRANSMISSION LINE (TD) IS FOR LOAD ONLY AND DOES NOT AFFECT THE DATA SHEET TIMING SPECIFICATIONS.
ANALOG DEVICES RECOMMENDS USING THE IBIS MODEL TIMING FOR A GIVEN SYSTEM REQUIREMENT. IF NECESSARY, A SYSTEM MAY INCORPORATE EXTERNAL DRIVERS TO COMPENSATE FOR ANY TIMING DIFFERENCES.

Figure 44. Equivalent Device Loading for AC Measurements (Includes All Fixtures)



Figure 45. Voltage Reference Levels for AC Measurements

OUTPUT DRIVE CURRENTS

[Figure 46](#) and [Figure 46](#) shows typical I-V characteristics for the output drivers of the ADSP-21469, and [Table 55](#) shows the pins associated with each driver. The curves represent the current drive capability of the output drivers as a function of output voltage.

Table 55. Driver Types

Driver Type	Associated Pins
A	LACK1-0, LDAT0[7:0], LDAT1[7:0], MLBCLK, MLBDAT, MLBDO, MLBSIG, MLBSO, AMI_ACK, AMI_ADDR23-0, AMI_DATA7-0, AMI_MS1-0, AMI_RD, AMI_WR, DAI_P, DPI_P, EMU, FLAG3-0, RESETOUT, TDO
B	LCLK1-0
C	DDR2_ADDR15-0, DDR2_BA2-0, DDR2_CAS, DDR2_CKE, DDR2_CS3-0, DDR2_DATA15-0, DDR2_DM1-0, DDR2_ODT, DDR2_RAS, DDR2_WE
D (TRUE)	DDR2_CLK1-0, DDR2_DQS1-0
D (COMP)	DDR2_CLK1-0, DDR2_DQS1-0

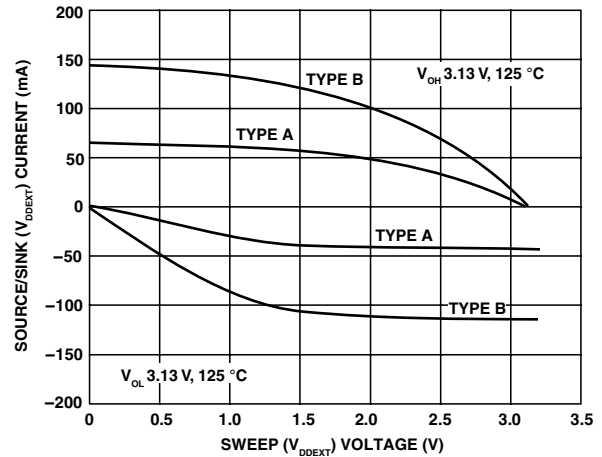

Figure 46. Output Buffer Characteristics (Worst-Case Non-DDR2)

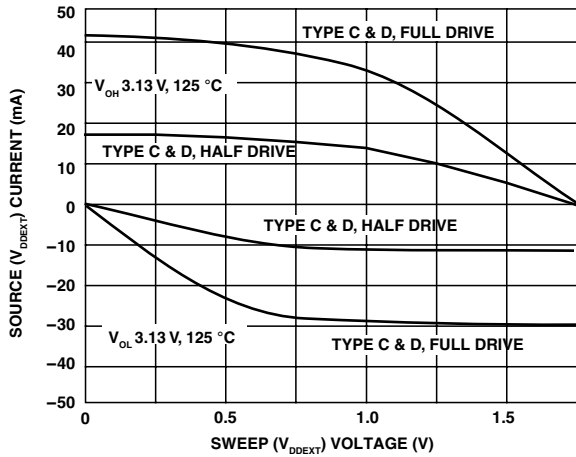

Figure 47. Output Buffer Characteristics (Worst-Case DDR2)

CAPACITIVE LOADING

Output delays and holds are based on standard capacitive loads: 30 pF on all pins (see Table 55). Figure 52 through Figure 57 show graphically how output delays and holds vary with load capacitance. The graphs of Figure 48 through Figure 57 may not be linear outside the ranges shown for Typical Output Delay vs. Load Capacitance and Typical Output Rise Time (20% to 80%, V = Min) vs. Load Capacitance.

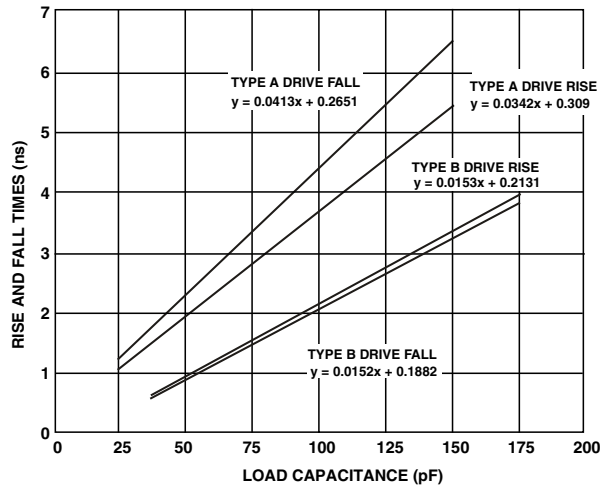

Figure 48. Typical Output Rise/Fall Time Non-DDR2 (20% to 80%, V_{DD_EXT} = Max)

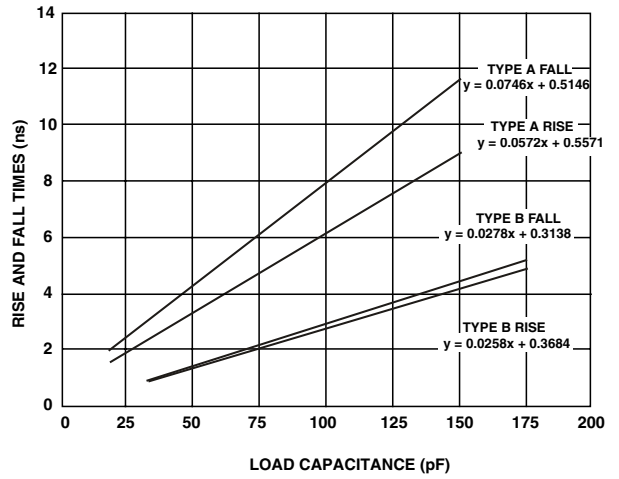

Figure 49. Typical Output Rise/Fall Time Non-DDR2 (20% to 80%, V_{DD_EXT} = Min)

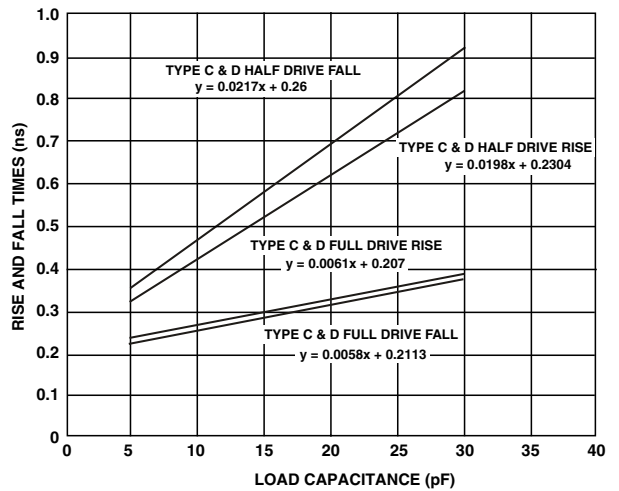

Figure 50. Typical Output Rise/Fall Time DDR2 (20% to 80%, V_{DD_EXT} = Max)

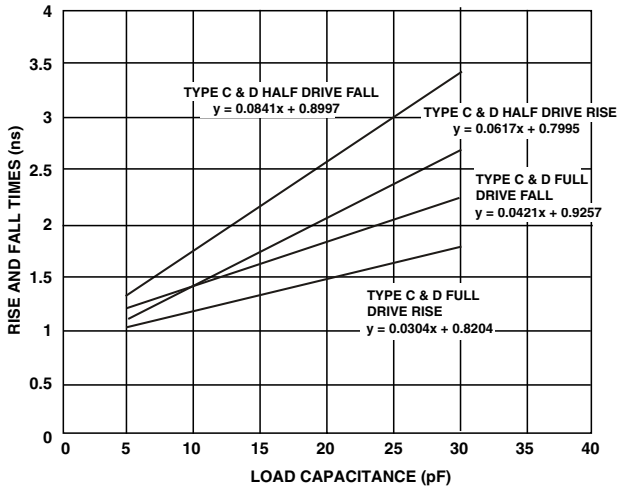

Figure 51. Typical Output Rise/Fall Time DDR2
(20% to 80%, $V_{DD_EXT} = \text{Min}$)

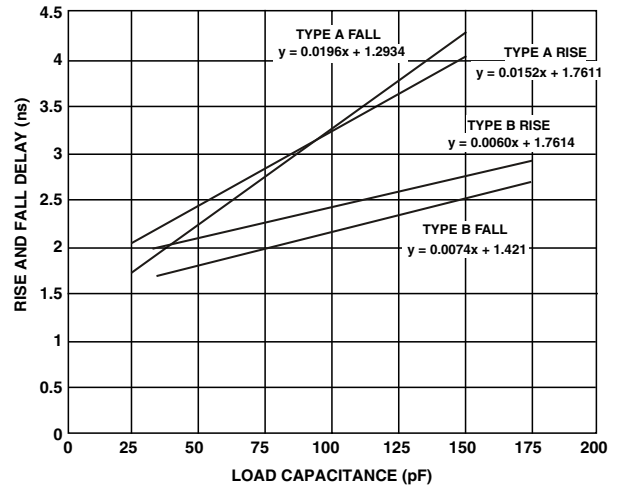

Figure 53. Typical Output Rise/Fall Delay No- DDR
($V_{DD_EXT} = \text{Max}$)

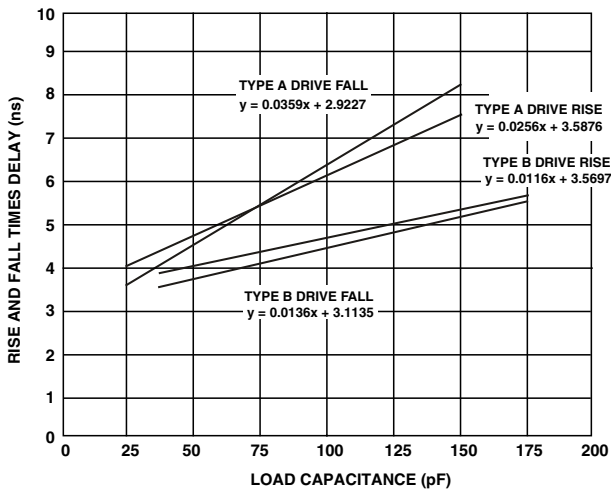

Figure 52. Typical Output Rise/Fall Delay Non-DDR
($V_{DD_EXT} = \text{Min}$)

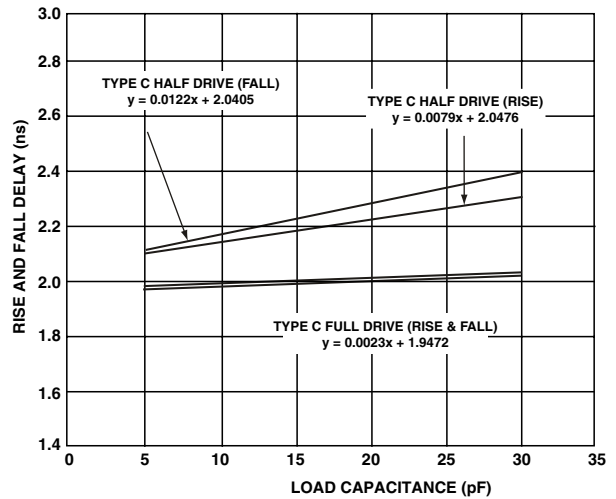

Figure 54. Typical Output Rise/Fall Delay DDR Pad C
($V_{DD_EXT} = \text{Min}$)

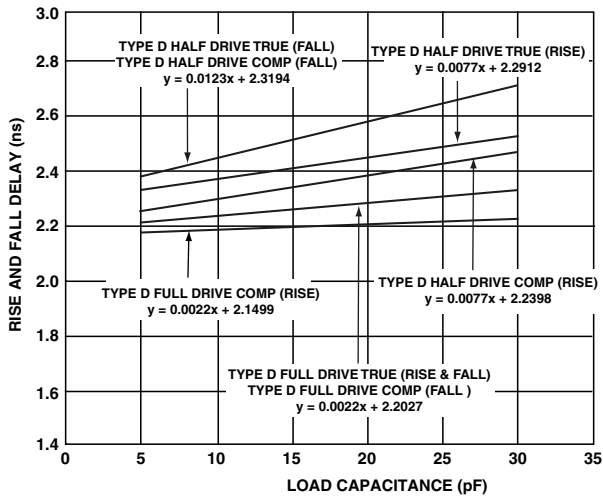

Figure 55. Typical Output Rise/Fall Delay DDR Pad D
($V_{DD_EXT} = Min$)

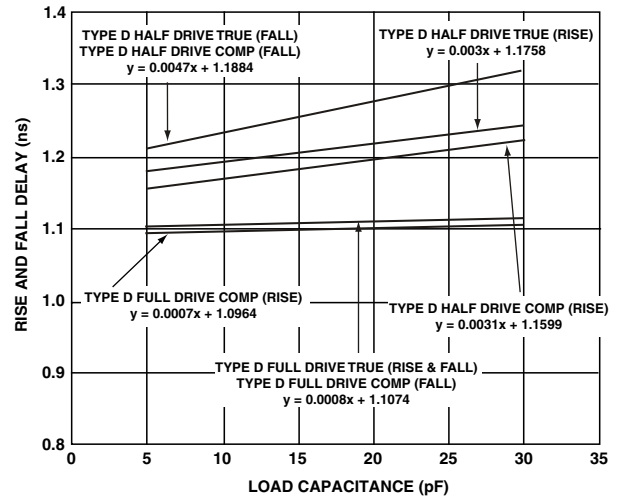

Figure 57. Typical Output Rise/Fall Delay DDR Pad D
($V_{DD_EXT} = Max$)

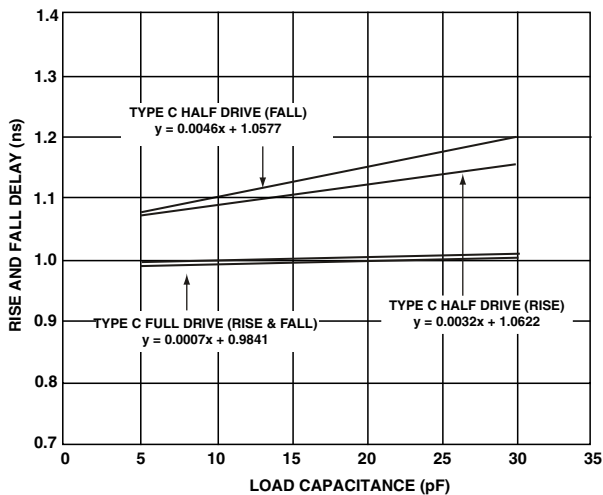

Figure 56. Typical Output Rise/Fall Delay DDR Pad C
($V_{DD_EXT} = Max$)

THERMAL CHARACTERISTICS

The ADSP-21469 processor is rated for performance over the temperature range specified in [Operating Conditions on Page 17](#).

[Table 56](#) airflow measurements comply with JEDEC standards JESD51-2 and JESD51-6, and the junction-to-board measurement complies with JESD51-8. Test board design complies with JEDEC standards JESD51-7 (CSP_BGA). The junction-to-case measurement complies with MIL-STD-883. All measurements use a 2S2P JEDEC test board.

To determine the junction temperature of the device while on the application PCB use:

T_J = junction temperature ($^{\circ}C$)

$$T_J = T_{CASE} + (\Psi_{JT} \times P_D)$$

where:

T_{CASE} = case temperature ($^{\circ}C$) measured at the top center of the package

Ψ_{JT} = junction-to-top (of package) characterization parameter is the typical value from [Table 56](#).

P_D = power dissipation

Values of θ_{JA} are provided for package comparison and PCB design considerations. θ_{JA} can be used for a first order approximation of T_J by the equation:

$$T_J = T_A + (\theta_{JA} \times P_D)$$

where:

T_A = ambient temperature $^{\circ}C$

Values of θ_{JC} are provided for package comparison and PCB design considerations when an external heat sink is required.

ADSP-21469

Values of θ_{JB} are provided for package comparison and PCB design considerations. Note that the thermal characteristics values provided in Table 56 are modeled values.

Table 56. Thermal Characteristics for 324-Lead CSP_BGA

Parameter	Condition	Typical	Unit
θ_{JA}	Airflow = 0 m/s	22.7	°C/W
θ_{JMA}	Airflow = 1 m/s	20.4	°C/W
θ_{JMA}	Airflow = 2 m/s	19.5	°C/W
θ_{JC}		6.6	°C/W
Ψ_{JT}	Airflow = 0 m/s	0.11	°C/W
Ψ_{JMT}	Airflow = 1 m/s	0.19	°C/W
Ψ_{JMT}	Airflow = 2 m/s	0.24	°C/W

Thermal Diode

The ADSP-21469 processors incorporate thermal diodes to monitor the die temperature. The thermal diode of is a grounded collector PNP bipolar junction transistor (BJT). The THD_P pin is connected to the emitter and the THD_M pin is connected to the base of the transistor. These pins can be used by an external temperature sensor (such as ADM 1021A or LM86, or others) to read the die temperature of the chip.

The technique used by the external temperature sensor is to measure the change in V_{BE} when the thermal diode is operated at two different currents. This is shown in the following equation:

$$\Delta V_{BE} = n \times \frac{kT}{q} \times \ln(N)$$

where:

Table 57. Thermal Diode Parameters—Transistor Model¹

Symbol	Parameter	Min	Typ	Max	Unit
I_{FW}^2	Forward Bias Current	10		300	μA
I_E	Emitter Current	10		300	μA
$nQ^{3,4}$	Transistor Ideality	1.012	1.015	1.017	
$R_T^{4,5}$	Series Resistance	0.12	0.2	0.28	Ω

¹ See the Engineer-to-Engineer Note EE-346.

² Analog Devices does not recommend operation of the thermal diode under reverse bias.

³ Not 100% tested. Specified by design characterization.

⁴ The ideality factor, nQ , represents the deviation from ideal diode behavior as exemplified by the diode equation: $I_C = I_S \times (e^{qV_{BE}/nqkT} - 1)$, where I_S = saturation current, q = electronic charge, V_{BE} = voltage across the diode, k = Boltzmann Constant, and T = absolute temperature (Kelvin).

⁵ The series resistance (R_T) can be used for more accurate readings as needed.

n = multiplication factor close to 1, depending on process variations

k = Boltzmann's constant

T = temperature (°C)

q = charge of the electron

N = ratio of the two currents

The two currents are usually in the range of 10 μA to 300 μA for the common temperature sensor chips available.

Table 57 contains the thermal diode specifications using the transistor model. Note that Measured Ideality Factor already takes into effect variations in beta (B).

CSP_BGA BALL ASSIGNMENT—AUTOMOTIVE MODELS

Table 58 lists the automotive CSP_BGA ball assignments by signal.

Table 58. CSP_BGA Ball Assignment (Alphabetical by Signal)

Signal	Ball No.	Signal	Ball No.	Signal	Ball No.	Signal	Ball No.
AGND	H02	CLK_CFG1	G02	DDR2_CKE	E01	DPI_P09	N01
AMI_ACK	R10	CLKIN	L01	$\overline{\text{DDR2_CLK0}}$	A07	DPI_P10	N02
AMI_ADDR0	V16	DAI_P01	R06	DDR2_CLK0	B07	DPI_P11	N03
AMI_ADDR01	U16	DAI_P02	V05	$\overline{\text{DDR2_CLK1}}$	A13	DPI_P12	N04
AMI_ADDR02	T16	DAI_P03	R07	DDR2_CLK1	B13	DPI_P13	M03
AMI_ADDR03	R16	DAI_P04	R03	$\overline{\text{DDR2_CS0}}$	C01	DPI_P14	M04
AMI_ADDR04	V15	DAI_P05	U05	$\overline{\text{DDR2_CS1}}$	D01	$\overline{\text{EMU}}$	K02
AMI_ADDR05	U15	DAI_P06	T05	$\overline{\text{DDR2_CS2}}$	C02	FLAG0	R08
AMI_ADDR06	T15	DAI_P07	V06	$\overline{\text{DDR2_CS3}}$	D02	FLAG1	V07
AMI_ADDR07	R15	DAI_P08	V02	DDR2_DATA0	B02	FLAG2	U07
AMI_ADDR08	V14	DAI_P09	R05	DDR2_DATA01	A02	FLAG3	T07
AMI_ADDR09	U14	DAI_P10	V04	DDR2_DATA02	B03	GND	A01
AMI_ADDR10	T14	DAI_P11	U04	DDR2_DATA03	A03	GND	A18
AMI_ADDR11	R14	DAI_P12	T04	DDR2_DATA04	B05	GND	C04
AMI_ADDR12	V13	DAI_P13	U06	DDR2_DATA05	A05	GND	C06
AMI_ADDR13	U13	DAI_P14	U02	DDR2_DATA06	B06	GND	C08
AMI_ADDR14	T13	DAI_P15	R04	DDR2_DATA07	A06	GND	D05
AMI_ADDR15	R13	DAI_P16	V03	DDR2_DATA08	B08	GND	D07
AMI_ADDR16	V12	DAI_P17	U03	DDR2_DATA09	A08	GND	D09
AMI_ADDR17	U12	DAI_P18	T03	DDR2_DATA10	B09	GND	D10
AMI_ADDR18	T12	DAI_P19	T06	DDR2_DATA11	A09	GND	D17
AMI_ADDR19	R12	DAI_P20	T02	DDR2_DATA12	A11	GND	E03
AMI_ADDR20	V11	DDR2_ADDR0	D13	DDR2_DATA13	B11	GND	E05
AMI_ADDR21	U11	DDR2_ADDR01	C13	DDR2_DATA14	A12	GND	E12
AMI_ADDR22	T11	DDR2_ADDR02	D14	DDR2_DATA15	B12	GND	E13
AMI_ADDR23	R11	DDR2_ADDR03	C14	DDR2_DM0	C03	GND	E16
AMI_DATA0	U18	DDR2_ADDR04	B14	DDR2_DM1	C11	GND	F01
AMI_DATA1	T18	DDR2_ADDR05	A14	DDR2_DQS0	A04	GND	F02
AMI_DATA2	R18	DDR2_ADDR06	D15	$\overline{\text{DDR2_DQS0}}$	B04	GND	F04
AMI_DATA3	P18	DDR2_ADDR07	C15	DDR2_DQS1	A10	GND	F14
AMI_DATA4	V17	DDR2_ADDR08	B15	$\overline{\text{DDR2_DQS1}}$	B10	GND	F16
AMI_DATA5	U17	DDR2_ADDR09	A15	DDR2_ODT	B01	GND	G03
AMI_DATA6	T17	DDR2_ADDR10	D16	$\overline{\text{DDR2_RAS}}$	C09	GND	G04
AMI_DATA7	R17	DDR2_ADDR11	C16	$\overline{\text{DDR2_WE}}$	C10	GND	G05
$\overline{\text{AMI_MS0}}$	T10	DDR2_ADDR12	B16	DPI_P01	R02	GND	G07
$\overline{\text{AMI_MS1}}$	U10	DDR2_ADDR13	A16	DPI_P02	U01	GND	G08
$\overline{\text{AMI_RD}}$	J04	DDR2_ADDR14	B17	DPI_P03	T01	GND	G09
$\overline{\text{AMI_WR}}$	V10	DDR2_ADDR15	A17	DPI_P04	R01	GND	G10
BOOT_CFG0	J02	DDR2_BA0	C18	DPI_P05	P01	GND	G11
BOOT_CFG1	J03	DDR2_BA1	C17	DPI_P06	P02	GND	G12
BOOT_CFG2	Ho3	DDR2_BA2	B18	DPI_P07	P03	GND	G15
CLK_CFG0	G01	$\overline{\text{DDR2_CAS}}$	C07	DPI_P08	P04	GND	H04

ADSP-21469

Table 58. CSP_BGA Ball Assignment (Alphabetical by Signal) (Continued)

Signal	Ball No.	Signal	Ball No.	Signal	Ball No.	Signal	Ball No.
GND	H07	GND	V01	V _{DD_DDR2}	E04	V _{DD_INT}	F13
GND	H08	GND	V18	V _{DD_DDR2}	E07	V _{DD_INT}	G06
GND	H09	LACK_0	K17	V _{DD_DDR2}	E10	V _{DD_INT}	G13
GND	H10	LACK_1	P17	V _{DD_DDR2}	E11	V _{DD_INT}	H05
GND	H11	LCLK_0	J18	V _{DD_DDR2}	E17	V _{DD_INT}	H06
GND	H12	LCLK_1	N18	V _{DD_DDR2}	F03	V _{DD_INT}	H13
GND	J01	LDAT0_0	E18	V _{DD_DDR2}	F05	V _{DD_INT}	H14
GND	J07	LDAT0_1	F17	V _{DD_DDR2}	F15	V _{DD_INT}	J06
GND	J08	LDAT0_2	F18	V _{DD_DDR2}	G14	V _{DD_INT}	J13
GND	J09	LDAT0_3	G17	V _{DD_DDR2}	G16	V _{DD_INT}	K06
GND	J10	LDAT0_4	G18	V _{DD_EXT}	H15	V _{DD_INT}	K13
GND	J11	LDAT0_5	H16	V _{DD_EXT}	H18	V _{DD_INT}	L06
GND	J12	LDAT0_6	H17	V _{DD_EXT}	J05	V _{DD_INT}	L13
GND	J14	LDAT0_7	J16	V _{DD_EXT}	J15	V _{DD_INT}	M06
GND	J17	LDAT1_0	K18	V _{DD_EXT}	K14	V _{DD_INT}	M13
GND	K05	LDAT1_1	L16	V _{DD_EXT}	L05	V _{DD_INT}	N06
GND	K07	LDAT1_2	L17	V _{DD_EXT}	M14	V _{DD_INT}	N07
GND	K08	LDAT1_3	L18	V _{DD_EXT}	M18	V _{DD_INT}	N08
GND	K09	LDAT1_4	M16	V _{DD_EXT}	N05	V _{DD_INT}	N09
GND	K10	LDAT1_5	M17	V _{DD_EXT}	P06	V _{DD_INT}	N13
GND	K11	LDAT1_6	N16	V _{DD_EXT}	P08	V _{DD_THD}	N10
GND	K12	LDAT1_7	P16	V _{DD_EXT}	P10	V _{REF}	D04
GND	L07	MLBCLK	K03	V _{DD_EXT}	P12	V _{REF}	D11
GND	L08	MLBDAT	K04	V _{DD_EXT}	P14	XTAL	K01
GND	L09	MLBSIG	L02	V _{DD_EXT}	P15		
GND	L10	MLBSO	L03	V _{DD_EXT}	T08		
GND	L11	MLBDO	L04	V _{DD_EXT}	T09		
GND	L12	RESET	M01	V _{DD_EXT}	U08		
GND	L14	RESETOUT/RUNRSTIN	M02	V _{DD_EXT}	U09		
GND	M05	TCK	K15	V _{DD_EXT}	V08		
GND	M07	TDI	L15	V _{DD_EXT}	V09		
GND	M08	TDO	M15	V _{DD_INT}	D12		
GND	M09	THD_M	N12	V _{DD_INT}	E06		
GND	M10	THD_P	N11	V _{DD_INT}	E08		
GND	M11	TMS	K16	V _{DD_INT}	E09		
GND	M12	TRST	N15	V _{DD_INT}	E14		
GND	N14	VDD_A	H01	V _{DD_INT}	E15		
GND	N17	V _{DD_DDR2}	C05	V _{DD_INT}	F06		
GND	P05	V _{DD_DDR2}	C12	V _{DD_INT}	F07		
GND	P07	V _{DD_DDR2}	D03	V _{DD_INT}	F08		
GND	P09	V _{DD_DDR2}	D06	V _{DD_INT}	F09		
GND	P11	V _{DD_DDR2}	D08	V _{DD_INT}	F10		
GND	P13	V _{DD_DDR2}	D18	V _{DD_INT}	F11		
GND	R09	V _{DD_DDR2}	E02	V _{DD_INT}	F12		

A1 CORNER
INDEX AREA

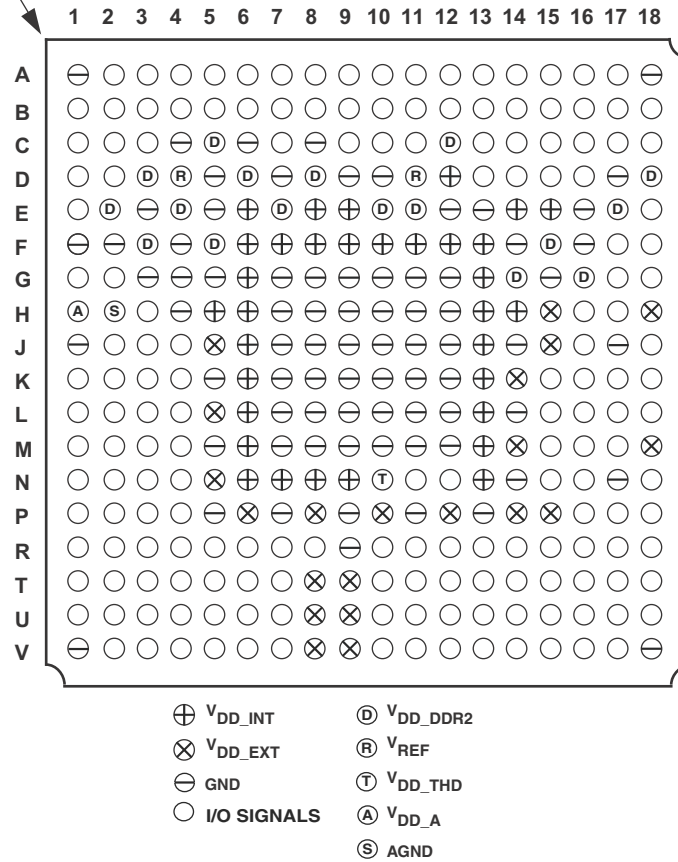

Figure 58. Ball Configuration, Automotive Model

ADSP-21469

CSP_BGA BALL ASSIGNMENT—STANDARD MODELS

Table 59 lists the standard model CSP_BGA ball assignments by signal.

Table 59. CSP_BGA Ball Assignment (Alphabetical by Signal)

Signal	Ball No.	Signal	Ball No.	Signal	Ball No.	Signal	Ball No.
AGND	H02	CLK_CFG1	G02	DDR2_CKE	E01	DPI_P09	N01
AMI_ACK	R10	CLKIN	L01	$\overline{\text{DDR2_CLK0}}$	A07	DPI_P10	N02
AMI_ADDR0	V16	DAI_P01	R06	DDR2_CLK0	B07	DPI_P11	N03
AMI_ADDR01	U16	DAI_P02	V05	$\overline{\text{DDR2_CLK1}}$	A13	DPI_P12	N04
AMI_ADDR02	T16	DAI_P03	R07	DDR2_CLK1	B13	DPI_P13	M03
AMI_ADDR03	R16	DAI_P04	R03	$\overline{\text{DDR2_CS0}}$	C01	DPI_P14	M04
AMI_ADDR04	V15	DAI_P05	U05	$\overline{\text{DDR2_CS1}}$	D01	$\overline{\text{EMU}}$	K02
AMI_ADDR05	U15	DAI_P06	T05	$\overline{\text{DDR2_CS2}}$	C02	FLAG0	R08
AMI_ADDR06	T15	DAI_P07	V06	$\overline{\text{DDR2_CS3}}$	D02	FLAG1	V07
AMI_ADDR07	R15	DAI_P08	V02	DDR2_DATA0	B02	FLAG2	U07
AMI_ADDR08	V14	DAI_P09	R05	DDR2_DATA01	A02	FLAG3	T07
AMI_ADDR09	U14	DAI_P10	V04	DDR2_DATA02	B03	GND	A01
AMI_ADDR10	T14	DAI_P11	U04	DDR2_DATA03	A03	GND	A18
AMI_ADDR11	R14	DAI_P12	T04	DDR2_DATA04	B05	GND	C04
AMI_ADDR12	V13	DAI_P13	U06	DDR2_DATA05	A05	GND	C06
AMI_ADDR13	U13	DAI_P14	U02	DDR2_DATA06	B06	GND	C08
AMI_ADDR14	T13	DAI_P15	R04	DDR2_DATA07	A06	GND	D05
AMI_ADDR15	R13	DAI_P16	V03	DDR2_DATA08	B08	GND	D07
AMI_ADDR16	V12	DAI_P17	U03	DDR2_DATA09	A08	GND	D09
AMI_ADDR17	U12	DAI_P18	T03	DDR2_DATA10	B09	GND	D10
AMI_ADDR18	T12	DAI_P19	T06	DDR2_DATA11	A09	GND	D17
AMI_ADDR19	R12	DAI_P20	T02	DDR2_DATA12	A11	GND	E03
AMI_ADDR20	V11	DDR2_ADDR0	D13	DDR2_DATA13	B11	GND	E05
AMI_ADDR21	U11	DDR2_ADDR01	C13	DDR2_DATA14	A12	GND	E12
AMI_ADDR22	T11	DDR2_ADDR02	D14	DDR2_DATA15	B12	GND	E13
AMI_ADDR23	R11	DDR2_ADDR03	C14	DDR2_DM0	C03	GND	E16
AMI_DATA0	U18	DDR2_ADDR04	B14	DDR2_DM1	C11	GND	F01
AMI_DATA1	T18	DDR2_ADDR05	A14	DDR2_DQS0	A04	GND	F02
AMI_DATA2	R18	DDR2_ADDR06	D15	$\overline{\text{DDR2_DQS0}}$	B04	GND	F04
AMI_DATA3	P18	DDR2_ADDR07	C15	DDR2_DQS1	A10	GND	F14
AMI_DATA4	V17	DDR2_ADDR08	B15	$\overline{\text{DDR2_DQS1}}$	B10	GND	F16
AMI_DATA5	U17	DDR2_ADDR09	A15	DDR2_ODT	B01	GND	G03
AMI_DATA6	T17	DDR2_ADDR10	D16	$\overline{\text{DDR2_RAS}}$	C09	GND	G04
AMI_DATA7	R17	DDR2_ADDR11	C16	$\overline{\text{DDR2_WE}}$	C10	GND	G05
$\overline{\text{AMI_MS0}}$	T10	DDR2_ADDR12	B16	DPI_P01	R02	GND	G07
$\overline{\text{AMI_MS1}}$	U10	DDR2_ADDR13	A16	DPI_P02	U01	GND	G08
$\overline{\text{AMI_RD}}$	J04	DDR2_ADDR14	B17	DPI_P03	T01	GND	G09
$\overline{\text{AMI_WR}}$	V10	DDR2_ADDR15	A17	DPI_P04	R01	GND	G10
BOOT_CFG0	J02	DDR2_BA0	C18	DPI_P05	P01	GND	G11
BOOT_CFG1	J03	DDR2_BA1	C17	DPI_P06	P02	GND	G12
BOOT_CFG2	H03	DDR2_BA2	B18	DPI_P07	P03	GND	G15
CLK_CFG0	G01	$\overline{\text{DDR2_CAS}}$	C07	DPI_P08	P04	GND	H04

Table 59. CSP_BGA Ball Assignment (Alphabetical by Signal) (Continued)

Signal	Ball No.	Signal	Ball No.	Signal	Ball No.	Signal	Ball No.
GND	H07	GND	V01	V _{DD_DDR2}	E04	V _{DD_INT}	F13
GND	H08	GND	V18	V _{DD_DDR2}	E07	V _{DD_INT}	G06
GND	H09	LACK_0	K17	V _{DD_DDR2}	E10	V _{DD_INT}	G13
GND	H10	LACK_1	P17	V _{DD_DDR2}	E11	V _{DD_INT}	H05
GND	H11	LCLK_0	J18	V _{DD_DDR2}	E17	V _{DD_INT}	H06
GND	H12	LCLK_1	N18	V _{DD_DDR2}	F03	V _{DD_INT}	H13
GND	J01	LDAT0_0	E18	V _{DD_DDR2}	F05	V _{DD_INT}	H14
GND	J07	LDAT0_1	F17	V _{DD_DDR2}	F15	V _{DD_INT}	J06
GND	J08	LDAT0_2	F18	V _{DD_DDR2}	G14	V _{DD_INT}	J13
GND	J09	LDAT0_3	G17	V _{DD_DDR2}	G16	V _{DD_INT}	K06
GND	J10	LDAT0_4	G18	V _{DD_EXT}	H15	V _{DD_INT}	K13
GND	J11	LDAT0_5	H16	V _{DD_EXT}	H18	V _{DD_INT}	L06
GND	J12	LDAT0_6	H17	V _{DD_EXT}	J05	V _{DD_INT}	L13
GND	J14	LDAT0_7	J16	V _{DD_EXT}	J15	V _{DD_INT}	M06
GND	J17	LDAT1_0	K18	V _{DD_EXT}	K14	V _{DD_INT}	M13
GND	K05	LDAT1_1	L16	V _{DD_EXT}	L05	V _{DD_INT}	N06
GND	K07	LDAT1_2	L17	V _{DD_EXT}	M14	V _{DD_INT}	N07
GND	K08	LDAT1_3	L18	V _{DD_EXT}	M18	V _{DD_INT}	N08
GND	K09	LDAT1_4	M16	V _{DD_EXT}	N05	V _{DD_INT}	N09
GND	K10	LDAT1_5	M17	V _{DD_EXT}	P06	V _{DD_INT}	N13
GND	K11	LDAT1_6	N16	V _{DD_EXT}	P08	V _{DD_THD}	N10
GND	K12	LDAT1_7	P16	V _{DD_EXT}	P10	V _{REF}	D04
GND	L07	NC	K03	V _{DD_EXT}	P12	V _{REF}	D11
GND	L08	NC	K04	V _{DD_EXT}	P14	XTAL	K01
GND	L09	NC	L02	V _{DD_EXT}	P15		
GND	L10	NC	L03	V _{DD_EXT}	T08		
GND	L11	NC	L04	V _{DD_EXT}	T09		
GND	L12	RESET	M01	V _{DD_EXT}	U08		
GND	L14	RESETOUT/RUNRSTIN	M02	V _{DD_EXT}	U09		
GND	M05	TCK	K15	V _{DD_EXT}	V08		
GND	M07	TDI	L15	V _{DD_EXT}	V09		
GND	M08	TDO	M15	V _{DD_INT}	D12		
GND	M09	THD_M	N12	V _{DD_INT}	E06		
GND	M10	THD_P	N11	V _{DD_INT}	E08		
GND	M11	TMS	K16	V _{DD_INT}	E09		
GND	M12	TRST	N15	V _{DD_INT}	E14		
GND	N14	VDD_A	H01	V _{DD_INT}	E15		
GND	N17	V _{DD_DDR2}	C05	V _{DD_INT}	F06		
GND	P05	V _{DD_DDR2}	C12	V _{DD_INT}	F07		
GND	P07	V _{DD_DDR2}	D03	V _{DD_INT}	F08		
GND	P09	V _{DD_DDR2}	D06	V _{DD_INT}	F09		
GND	P11	V _{DD_DDR2}	D08	V _{DD_INT}	F10		
GND	P13	V _{DD_DDR2}	D18	V _{DD_INT}	F11		
GND	R09	V _{DD_DDR2}	E02	V _{DD_INT}	F12		

A1 CORNER
INDEX AREA

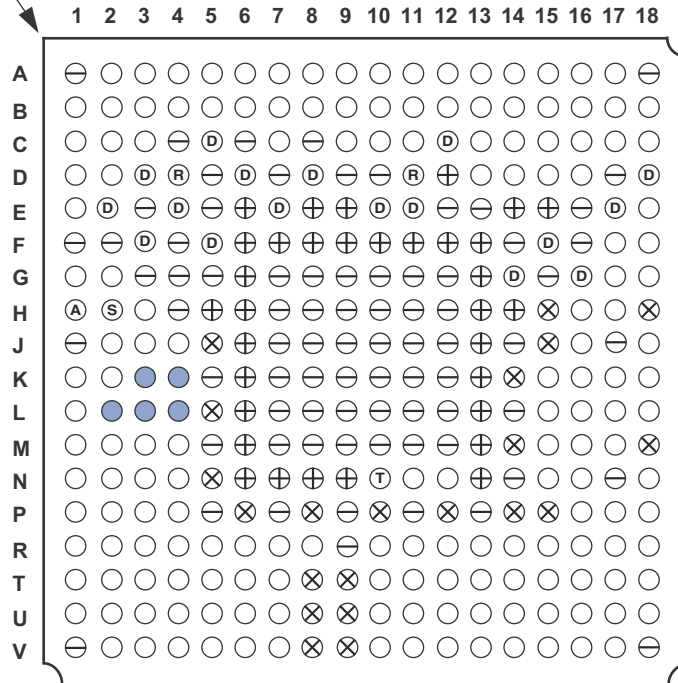

- | | | | |
|---|---------------------|---|----------------------|
| ⊕ | V _{DD_INT} | ⊕ | V _{DD_DDR2} |
| ⊗ | V _{DD_EXT} | ⊕ | V _{REF} |
| ⊖ | GND | ⊕ | V _{DD_THD} |
| ● | NC | ⊕ | V _{DD_A} |
| ○ | I/O SIGNALS | ⊕ | AGND |

Figure 59. Ball Configuration, Standard Model

OUTLINE DIMENSIONS

The ADSP-21469 processor is available in a 19 mm by 19 mm CSP_BGA lead-free package.

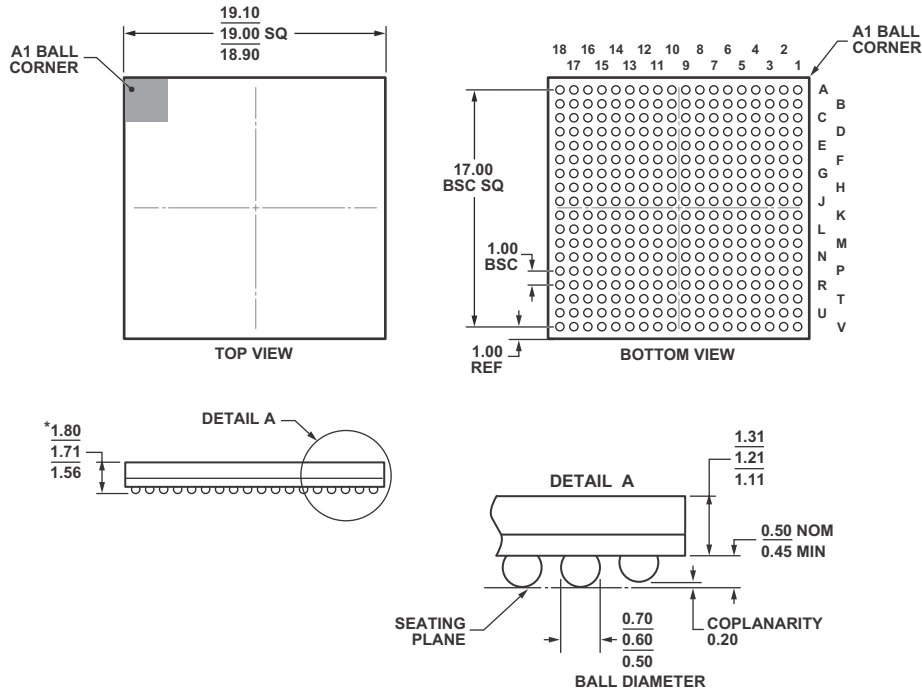

*COMPLIANT TO JEDEC STANDARDS MO-192-AAG-1 WITH THE EXCEPTION TO PACKAGE HEIGHT.

Figure 60. 324-Ball Chip Scale Package, Ball Grid Array [CSP_BGA] (BC-324-1)

Dimensions shown in millimeters

SURFACE-MOUNT DESIGN

The following table is provided as an aid to PCB design. For industry-standard design recommendations, refer to IPC-7351, *Generic Requirements for Surface-Mount Design and Land Pattern Standard*.

Package	Package Ball Attach Type	Package Solder Mask Opening	Package Ball Pad Size
324-Ball CSP_BGA (BC-324-1)	Solder Mask Defined	0.43 mm diameter	0.6 mm diameter

ADSP-21469

AUTOMOTIVE PRODUCTS

The ADSP-21469W model is available with controlled manufacturing to support the quality and reliability requirements of automotive applications. Note that automotive models may have specifications that differ from commercial models and designers should review the Specifications section of this data

sheet carefully. Only the automotive grade products shown in [Table 60](#) are available for use in automotive applications. Contact your local ADI account representative for specific product ordering information and to obtain the specific Automotive Reliability reports for these models.

Table 60. Automotive Products

Model ¹	Temperature Range ²	On-Chip SRAM	Package Description	Package Option
AD21469WBBCZ3xx ³	-40°C to +85°C	5M bit	324-Ball Grid Array (CSP_BGA)	BC-324-1

¹ Z = RoHS compliant part.

² Referenced temperature is ambient temperature. The ambient temperature is not a specification. Please see [Operating Conditions on Page 17](#) for junction temperature (T_j) specification, which is the only temperature specification.

³ xx denotes silicon revision.

ORDERING GUIDE

Model ¹	Temperature Range ²	On-Chip SRAM	Processor Instruction Rate (Max)	Package Description	Package Option
ADSP-21469KBCZ-3	0°C to +70°C	5M bit	400 MHz	324-Ball Grid Array (CSP_BGA)	BC-324-1
ADSP-21469BBCZ-3	-40°C to +85°C	5M bit	400 MHz	324-Ball Grid Array (CSP_BGA)	BC-324-1
ADSP-21469KBCZ-4	0°C to +70°C	5M bit	450 MHz	324-Ball Grid Array (CSP_BGA)	BC-324-1

¹ Z = RoHS compliant part.

² Referenced temperature is ambient temperature. The ambient temperature is not a specification. Please see [Operating Conditions on Page 17](#) for junction temperature (T_j) specification, which is the only temperature specification.

Компания «Life Electronics» занимается поставками электронных компонентов импортного и отечественного производства от производителей и со складов крупных дистрибьюторов Европы, Америки и Азии.

С конца 2013 года компания активно расширяет линейку поставок компонентов по направлению коаксиальный кабель, кварцевые генераторы и конденсаторы (керамические, пленочные, электролитические), за счёт заключения дистрибьюторских договоров

Мы предлагаем:

- Конкурентоспособные цены и скидки постоянным клиентам.
- Специальные условия для постоянных клиентов.
- Подбор аналогов.
- Поставку компонентов в любых объемах, удовлетворяющих вашим потребностям.
- Приемлемые сроки поставки, возможна ускоренная поставка.
- Доставку товара в любую точку России и стран СНГ.
- Комплексную поставку.
- Работу по проектам и поставку образцов.
- Формирование склада под заказчика.
- Сертификаты соответствия на поставляемую продукцию (по желанию клиента).
- Тестирование поставляемой продукции.
- Поставку компонентов, требующих военную и космическую приемку.
- Входной контроль качества.
- Наличие сертификата ISO.

В составе нашей компании организован Конструкторский отдел, призванный помогать разработчикам, и инженерам.

Конструкторский отдел помогает осуществить:

- Регистрацию проекта у производителя компонентов.
- Техническую поддержку проекта.
- Защиту от снятия компонента с производства.
- Оценку стоимости проекта по компонентам.
- Изготовление тестовой платы монтаж и пусконаладочные работы.



Тел: +7 (812) 336 43 04 (многоканальный)

Email: org@lifeelectronics.ru