

# ISL90842

Quad Digitally Controlled Variable Resistors Low Noise, Low Power I<sup>2</sup>C Bus, 256 Taps

FN8096  
Rev 1.00  
January 16, 2006

The ISL90842 integrates four digitally controlled potentiometers (DCP) configured as variable resistors on a monolithic CMOS integrated circuit.

The digitally controlled potentiometers are implemented with a combination of resistor elements and CMOS switches. The position of the wipers are controlled by the user through the I<sup>2</sup>C bus interface. Each potentiometer has an associated Wiper Register (WR) that can be directly written to and read by the user. The contents of the WR controls the position of the wiper.

The DCPs can be used as two-terminal variable resistors in a wide variety of applications including control, parameter adjustments, and signal processing.

## Pinout

ISL90842  
(14 LEAD TSSOP)  
TOP VIEW

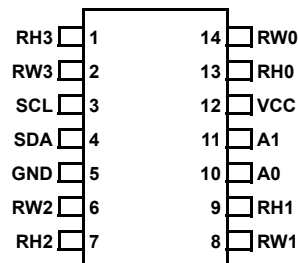

## Features

- Four variable resistors in one package
- 256 resistor taps - 0.4% resolution
- I<sup>2</sup>C serial interface
- Wiper resistance: 70Ω typical @ 3.3V
- Standby current <5μA max
- Power supply: 2.7V to 5.5V
- 50kΩ, 10kΩ total resistance
- 14 Lead TSSOP
- Pb-free plus anneal available (RoHS compliant)

## Ordering Information

| PART NUMBER                    | PART MARKING | RESISTANCE OPTION (Ω) | TEMP RANGE (°C) | PACKAGE               |
|--------------------------------|--------------|-----------------------|-----------------|-----------------------|
| ISL90842UIV1427Z (Notes 1 & 2) | 90842UI27Z   | 50K                   | -40 to +85      | 14 Ld TSSOP (Pb-Free) |
| ISL90842WIV1427Z (Notes 1 & 2) | 90842WI27Z   | 10K                   | -40 to +85      | 14 Ld TSSOP (Pb-Free) |

NOTES:

1. Intersil Pb-free plus anneal products employ special Pb-free material sets; molding compounds/die attach materials and 100% matte tin plate termination finish, which are RoHS compliant and compatible with both SnPb and Pb-free soldering operations. Intersil Pb-free products are MSL classified at Pb-free peak reflow temperatures that meet or exceed the Pb-free requirements of IPC/JEDEC J STD-020.
2. Add "-TK" suffix for Tape and Reel.

**Functional Diagram**

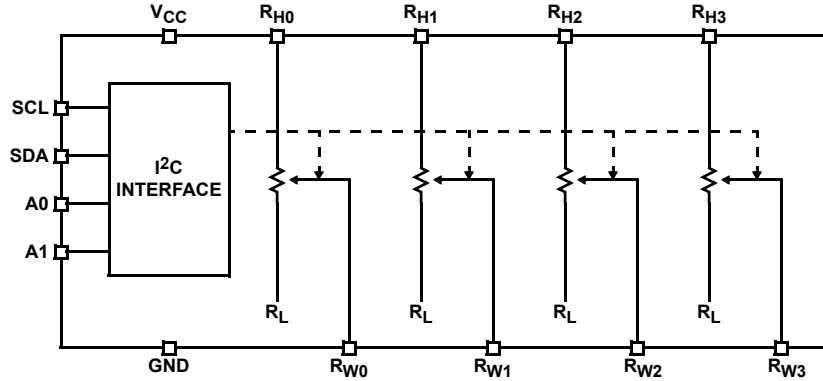

**Block Diagram**

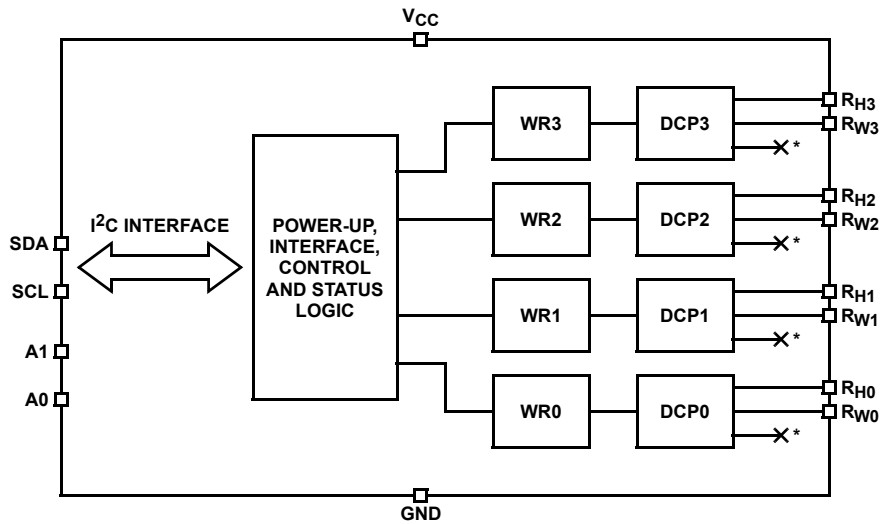

\* THE R<sub>L</sub> PINS OF EACH DCP ARE LEFT FLOATING

**Pin Descriptions**

| TSSOP PIN | SYMBOL | DESCRIPTION  |
|-----------|--------|--|
| 1         | RH3    | "High" terminal of DCP3                            |
| 2         | RW3    | "Wiper" terminal of DCP3                           |
| 3         | SCL    | I <sup>2</sup> C interface clock                   |
| 4         | SDA    | Serial data I/O for the I <sup>2</sup> C interface |
| 5         | GND    | Device ground pin                                  |
| 6         | RW2    | "Wiper" terminal of DCP2                           |
| 7         | RH2    | "High" terminal of DCP2                            |
| 8         | RW1    | "Wiper" terminal of DCP1                           |
| 9         | RH1    | "High" terminal of DCP1                            |
| 10        | A0     | Device address for the I <sup>2</sup> C interface  |
| 11        | A1     | Device address for the I <sup>2</sup> C interface  |
| 12        | VCC    | Power supply pin                                   |
| 13        | RH0    | "High" terminal of DCP0                            |
| 14        | RW0    | "Wiper" terminal of DCP0                           |

**Absolute Maximum Ratings**

|  |                            |
|--|----------------------------|
| Storage temperature                                      | -65°C to +150°C            |
| Voltage at any digital interface pin with respect to GND | -0.3V to $V_{CC}+0.3$      |
| $V_{CC}$   | -0.3V to +6V               |
| Voltage at any DCP pin with respect to GND               | -0.3V to $V_{CC}$          |
| Lead temperature (soldering, 10s)                        | 300°C                      |
| $I_W$ (10s)  | ±6mA                       |
| Latchup  | Class II, Level B at +85°C |
| ESD  | >2kV Human Body Model      |

**Recommended Operating Conditions**

|                           |                |
|---------------------------|----------------|
| Industrial                | -40°C to +85°C |
| $V_{CC}$                  | 2.7V to 5.5V   |
| Power rating of each DCP  | .5mW           |
| Wiper current of each DCP | ±3.0mA         |

**CAUTION:** Stresses above those listed in "Absolute Maximum Ratings" may cause permanent damage to the device. This is a stress only rating and operation of the device at these or any other conditions above those indicated in the operational sections of this specification is not implied.

**Analog Specifications** Over recommended operating conditions unless otherwise stated.

| SYMBOL  | PARAMETER                           | TEST CONDITIONS  | MIN  | TYP (NOTE 1) | MAX | UNIT        |
|---|-------------------------------------|--|------|--------------|-----|-------------|
| $R_{TOTAL}$   | $R_H$ to $R_W$ resistance           | W option, wiper counter = 00h  |      | 10           |     | k $\Omega$  |
|   |                                     | U option, wiper counter = 00h  |      | 50           |     | k $\Omega$  |
|   | $R_H$ to $R_W$ resistance tolerance | Wiper counter = 00h  | -20  |              | +20 | %           |
| $R_W$   | Wiper resistance                    | $V_{CC} = 3.3V @ 25^\circ C$ , wiper current = $V_{CC}/R_{TOTAL}$            |      | 70           | 200 | $\Omega$    |
| $C_H/C_L/C_W$   | Potentiometer capacitance (Note 15) |  |      | 10/10/25     |     | pF          |
| $I_{LkgDCP}$  | Leakage on DCP pins (Note 15)       | Voltage at pin from GND to $V_{CC}$  |      | 0.1          | 1   | $\mu A$     |
| <b>RESISTOR MODE</b> (Measurements between $R_{Wi}$ and $R_{Hi}$ , $i = 0, 1, 2$ or $3$ ) |                                     |  |      |              |     |             |
| $R_{INL}$ (Note 5)  | Integral non-linearity              | DCP register set between 20 hex and FF hex; monotonic over all tap positions | -1   |              | 1   | MI (Note 2) |
| $R_{DNL}$ (Note 4)  | Differential non-linearity          |  | -0.5 |              | 0.5 | MI (Note 2) |
| $R_{offset}$ (Note 3)   | Offset                              | U option   | 0    | 1            | 7   | MI (Note 2) |
|   |                                     | W option   | 0    | 0.5          | 2   | MI (Note 2) |
| $R_{MATCH}$ (Note 6)  | DCP to DCP matching                 | Any two DCPs at the same tap position with the same terminal voltages        | -2   |              | 2   | MI (Note 2) |
| $TC_R$ (Note 7)   | Resistance temperature coefficient  | DCP register set between 20 hex and FF hex                                   |      | ±45          |     | ppm/°C      |

**Operating Specifications** Over the recommended operating conditions unless otherwise specified.

| SYMBOL       | PARAMETER                                     | TEST CONDITIONS  | MIN | TYP (NOTE 1) | MAX | UNIT    |
|--------------|---|--|-----|--------------|-----|---------|
| $I_{CC1}$    | $V_{CC}$ supply current (volatile write/read) | $f_{SCL} = 400kHz$ ; SDA = Open; (for I <sup>2</sup> C, active, read and write states) |     |              | 1   | mA      |
| $I_{SB}$     | $V_{CC}$ current (standby)                    | $V_{CC} = +5.5V$ , I <sup>2</sup> C interface in standby state                         |     |              | 5   | $\mu A$ |
|              |   | $V_{CC} = +3.6V$ , I <sup>2</sup> C interface in standby state                         |     |              | 2   | $\mu A$ |
| $I_{LkgDig}$ | Leakage current, at pins A0, A1, SDA, and SCL | Voltage at pin from GND to $V_{CC}$  | -10 |              | 10  | $\mu A$ |

**Operating Specifications** Over the recommended operating conditions unless otherwise specified. (Continued)

| SYMBOL                        | PARAMETER  | TEST CONDITIONS   | MIN                  | TYP<br>(NOTE 1) | MAX                | UNIT       |
|-------------------------------|--|---|----------------------|-----------------|--------------------|------------|
| $t_{DCP}$<br>(Note 8)         | DCP wiper response time  | SCL falling edge of last bit of DCP data byte to wiper change   |                      |                 | 1                  | $\mu$ s    |
| <b>SERIAL INTERFACE SPECS</b> |  |   |                      |                 |                    |            |
| $V_{IL}$                      | A1, A0, SDA, and SCL input buffer LOW voltage                    |   | -0.3                 |                 | $0.3 \cdot V_{CC}$ | V          |
| $V_{IH}$                      | A1, A0, SDA, and SCL input buffer HIGH voltage                   |   | $0.7 \cdot V_{CC}$   |                 | $V_{CC} + 0.3$     | V          |
| Hysteresis<br>(Note 8)        | SDA and SCL input buffer hysteresis                              |   | $0.05 \cdot V_{CC}$  |                 |                    | V          |
| $V_{OL}$<br>(Note 8)          | SDA output buffer LOW voltage, sinking 4mA                       |   | 0                    |                 | 0.4                | V          |
| $C_{pin}$<br>(Note 8)         | A1, A0, SDA, and SCL pin capacitance                             |   |                      |                 | 10                 | pF         |
| $f_{SCL}$                     | SCL frequency  |   |                      |                 | 400                | kHz        |
| $t_{IN}$<br>(Note 8)          | Pulse width suppression time at SDA and SCL inputs               | Any pulse narrower than the max spec is suppressed  |                      |                 | 50                 | ns         |
| $t_{AA}$<br>(Note 8)          | SCL falling edge to SDA output data valid                        | SCL falling edge crossing 30% of $V_{CC}$ , until SDA exits the 30% to 70% of $V_{CC}$ window   |                      |                 | 900                | ns         |
| $t_{BUF}$<br>(Note 8)         | Time the bus must be free before the start of a new transmission | SDA crossing 70% of $V_{CC}$ during a STOP condition, to SDA crossing 70% of $V_{CC}$ during the following START condition                      | 1300                 |                 |                    | ns         |
| $t_{LOW}$                     | Clock LOW time   | Measured at the 30% of $V_{CC}$ crossing  | 1300                 |                 |                    | ns         |
| $t_{HIGH}$                    | Clock HIGH time  | Measured at the 70% of $V_{CC}$ crossing  | 600                  |                 |                    | ns         |
| $t_{SU:STA}$                  | START condition setup time                                       | SCL rising edge to SDA falling edge; both crossing 70% of $V_{CC}$  | 600                  |                 |                    | ns         |
| $t_{HD:STA}$                  | START condition hold time  | From SDA falling edge crossing 30% of $V_{CC}$ to SCL falling edge crossing 70% of $V_{CC}$   | 600                  |                 |                    | ns         |
| $t_{SU:DAT}$                  | Input data setup time  | From SDA exiting the 30% to 70% of $V_{CC}$ window, to SCL rising edge crossing 30% of $V_{CC}$   | 100                  |                 |                    | ns         |
| $t_{HD:DAT}$                  | Input data hold time   | From SCL rising edge crossing 70% of $V_{CC}$ to SDA entering the 30% to 70% of $V_{CC}$ window   | 0                    |                 |                    | ns         |
| $t_{SU:STO}$                  | STOP condition hold time   | From SCL rising edge crossing 70% of $V_{CC}$ , to SDA rising edge crossing 30% of $V_{CC}$   | 600                  |                 |                    | ns         |
| $t_{HD:STO}$                  | STOP condition hold time for read, or volatile only write        | From SDA rising edge to SCL falling edge. Both crossing 70% of $V_{CC}$   | 600                  |                 |                    | ns         |
| $t_{DH}$<br>(Note 8)          | Output data hold time  | From SCL falling edge crossing 30% of $V_{CC}$ , until SDA enters the 30% to 70% of $V_{CC}$ window   | 0                    |                 |                    | ns         |
| $t_R$<br>(Note 8)             | SDA and SCL rise time  | From 30% to 70% of $V_{CC}$   | $20 + 0.1 \cdot C_b$ |                 | 250                | ns         |
| $t_F$<br>(Note 8)             | SDA and SCL fall time  | From 70% to 30% of $V_{CC}$   | $20 + 0.1 \cdot C_b$ |                 | 250                | ns         |
| $C_b$ (Note 8)                | Capacitive loading of SDA or SCL                                 | Total on-chip and off-chip  | 10                   |                 | 400                | pF         |
| $R_{pu}$<br>(Note 8)          | SDA and SCL bus pull-up resistor off-chip                        | Maximum is determined by $t_R$ and $t_F$<br>For $C_b = 400$ pF, max is about 2~2.5k $\Omega$<br>For $C_b = 40$ pF, max is about 15~20k $\Omega$ | 1                    |                 |                    | k $\Omega$ |

**Operating Specifications** Over the recommended operating conditions unless otherwise specified. (Continued)

| SYMBOL     | PARAMETER            | TEST CONDITIONS        | MIN | TYP<br>(NOTE 1) | MAX | UNIT |
|------------|----------------------|------------------------|-----|-----------------|-----|------|
| $t_{SU:A}$ | A1 and A0 setup time | Before START condition | 600 |                 |     | ns   |
| $t_{HD:A}$ | A1 and A0 hold time  | After STOP condition   | 600 |                 |     | ns   |

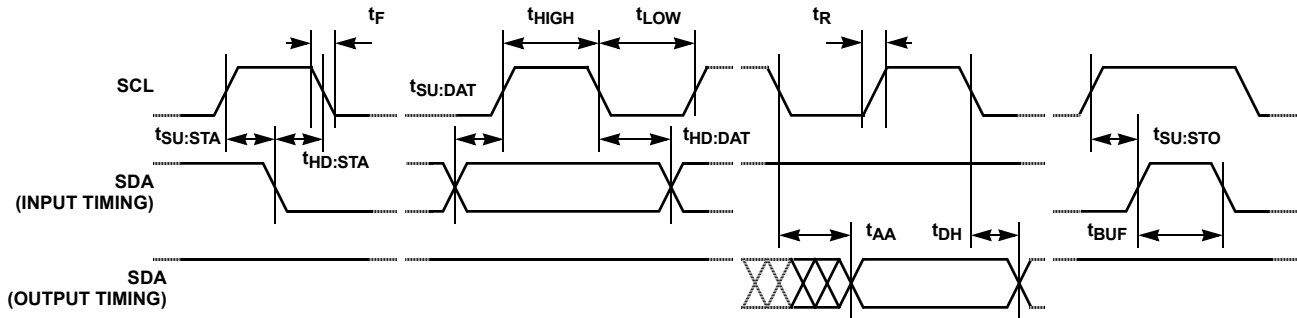
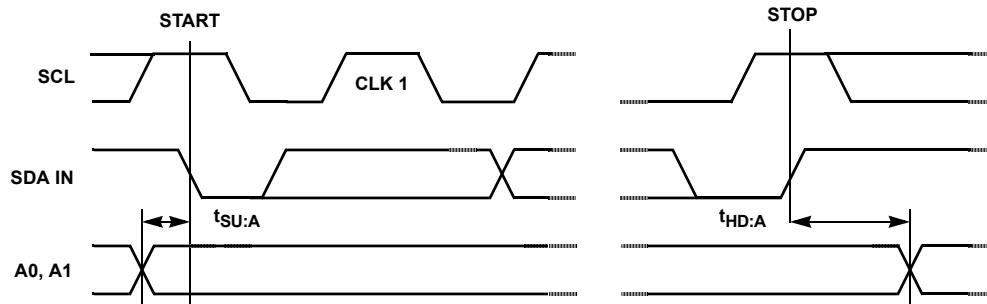
**SDA vs SCL Timing****A0 and A1 Pin Timing**

## NOTES:

- Typical values are for  $T_A = 25^\circ\text{C}$  and 3.3V supply voltage.
- $MI = |R_{255} - R_0| / 255$ .  $R_{255}$  and  $R_0$  are the measured resistances for the DCP register set to FF hex and 00 hex, respectively.
- $R_{offset} = R_{255} / MI$ , when measuring between  $R_W$  and  $R_H$ .
- $RDNL = (R_i - R_{i-1}) / MI$ , for  $i = 32$  to 255.
- $RINL = [R_i - (MI \cdot i) - R_0] / MI$ , for  $i = 32$  to 255.
- $R_{MATCH} = (R_{i,x} - R_{i,y}) / MI$ , for  $i = 0$  to 255,  $x = 0$  to 3 and  $y = 0$  to 3.
- $TC_R = \frac{[\text{Max}(R_i) - \text{Min}(R_i)]}{[\text{Max}(R_i) + \text{Min}(R_i)]/2} \times \frac{10^6}{125^\circ\text{C}}$  for  $i = 32$  to 255,  $T = -40^\circ\text{C}$  to  $85^\circ\text{C}$ .  $\text{Max}()$  is the maximum value of the resistance and  $\text{Min}()$  is the minimum value of the resistance over the temperature range.
- This parameter is not 100% tested.

### Typical Performance Curves

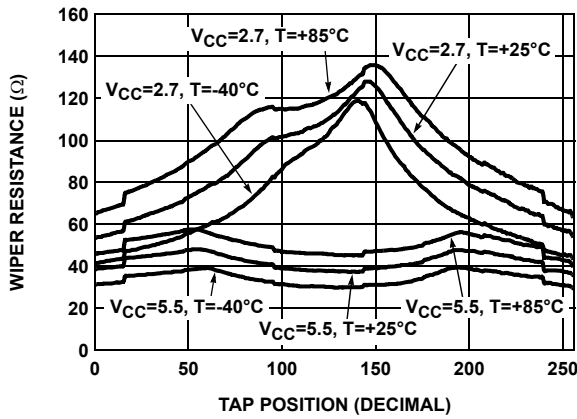

FIGURE 1. WIPER RESISTANCE vs TAP POSITION [I(R<sub>W</sub>) = V<sub>CC</sub> / R<sub>TOTAL</sub>] FOR 50kΩ (U)

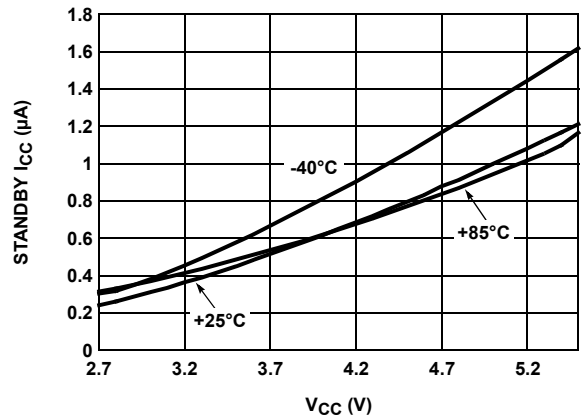

FIGURE 2. STANDBY I<sub>CC</sub> vs V<sub>CC</sub>

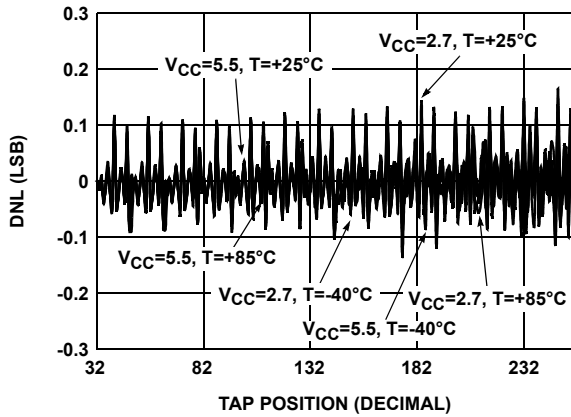

FIGURE 3. DNL vs TAP POSITION FOR 50kΩ (U)

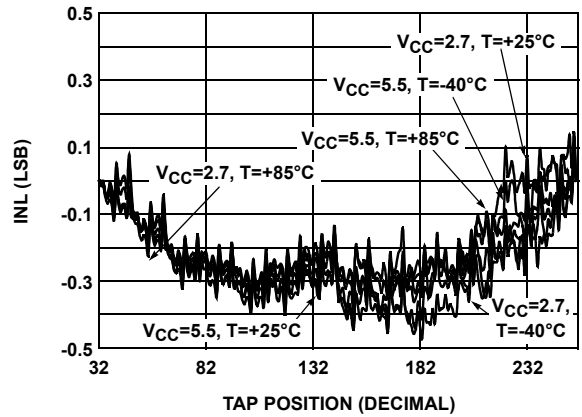

FIGURE 4. INL vs TAP POSITION FOR 50kΩ (U)

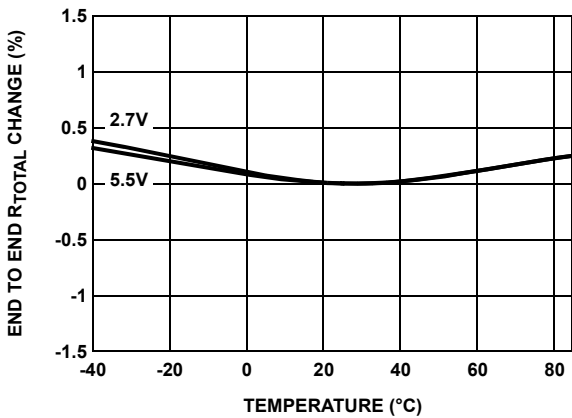

FIGURE 5. END TO END R<sub>TOTAL</sub> % CHANGE vs TEMPERATURE

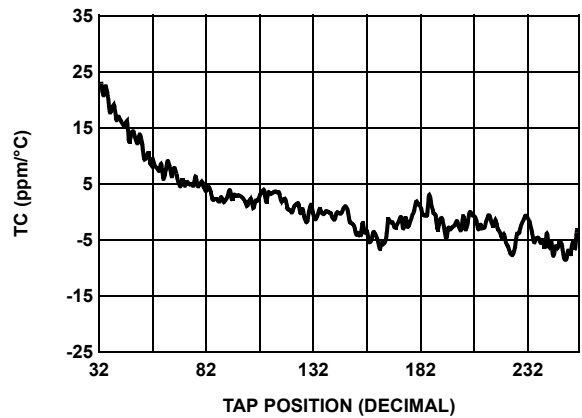

FIGURE 6. TC IN ppm

## Typical Performance Curves (Continued)

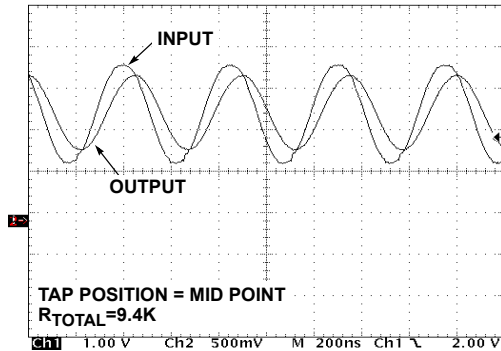

FIGURE 7. FREQUENCY RESPONSE (2.2MHz)

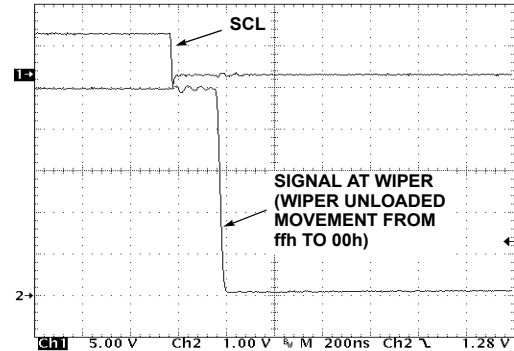

FIGURE 8. LARGE SIGNAL SETTLING TIME

### Principles of Operation

The ISL90842 is an integrated circuit incorporating four DCPs with their associated registers, and an I<sup>2</sup>C serial interface providing direct communication between a host and the DCPs.

#### DCP Description

Each DCP is implemented with a combination of resistor elements and CMOS switches. The physical ends of each DCP are equivalent to the fixed terminals of a mechanical potentiometer. The  $R_W$  pin of each DCP is connected to intermediate nodes, and is equivalent to the wiper terminal of a mechanical potentiometer. The position of the wiper terminal within the DCP is controlled by an 8-bit volatile Wiper Register (WR). Each DCP has its own WR. When the WR of a DCP contains all zeroes (WR<7:0>: 00h), its wiper terminal ( $R_W$ ) is closest to its  $R_L$  terminal. When the WR of a DCP contains all ones (WR<7:0>: FFh), its wiper terminal ( $R_W$ ) is furthest from the  $R_H$  terminal. As the value of the WR increases from all zeroes (00h) to all ones (255 decimal), the wiper moves monotonically from the position furthest from  $R_H$  to a position closer to  $R_H$ . At the same time, the resistance between  $R_H$  and  $R_W$  decreases monotonically. Note that the  $R_L$  terminals for all four pots are not connected (left floating).

While the ISL90842 is being powered up, all four WRs are reset to 80h (128 decimal), which locates  $R_W$  roughly at a position which yields a rheostat setting that is about 1/2 of  $R_{TOTAL}$ .

The WRs can be read or written directly using the I<sup>2</sup>C serial interface as described in the following sections. The I<sup>2</sup>C interface Address Byte has to be set to 00h, 01h, 02h, and 03h to access the WR of DCP0, DCP1, DCP2, and DCP3, respectively.

receiver pulls the SDA line LOW to acknowledge the

### I<sup>2</sup>C Serial Interface

The ISL90842 supports a bidirectional bus oriented protocol. The protocol defines any device that sends data onto the bus as a transmitter and the receiving device as the receiver. The device controlling the transfer is a master and the device being controlled is the slave. The master always initiates data transfers and provides the clock for both transmit and receive operations. Therefore, the ISL90842 operates as a slave device in all applications.

All communication over the I<sup>2</sup>C interface is conducted by sending the MSB of each byte of data first.

#### Protocol Conventions

Data states on the SDA line must change only during SCL LOW periods. SDA state changes during SCL HIGH are reserved for indicating START and STOP conditions (See Figure 9). On power-up of the ISL90842 the SDA pin is in the input mode.

All I<sup>2</sup>C interface operations must begin with a START condition, which is a HIGH to LOW transition of SDA while SCL is HIGH. The ISL90842 continuously monitors the SDA and SCL lines for the START condition and does not respond to any command until this condition is met (See Figure 9). A START condition is ignored during the power-up of the device.

All I<sup>2</sup>C interface operations must be terminated by a STOP condition, which is a LOW to HIGH transition of SDA while SCL is HIGH (See Figure 9). A STOP condition at the end of a read operation, or at the end of a write operation places the device in its standby mode.

An ACK, Acknowledge, is a software convention used to indicate a successful data transfer. The transmitting device, either master or slave, releases the SDA bus after transmitting eight bits. During the ninth clock cycle, the reception of the eight bits of data (See Figure 10).

The ISL90842 responds with an ACK after recognition of a START condition followed by a valid Identification Byte, and once again after successful receipt of an Address Byte. The ISL90842 also responds with an ACK after receiving a Data Byte of a write operation. The master must respond with an ACK after receiving a Data Byte of a read operation

A valid Identification Byte contains 01010 as the five MSBs, and the following two bits matching the logic values present at pins A1 and A0. The LSB is the Read/Write bit. Its value is

“1” for a Read operation, and “0” for a Write operation (See Table 1).

**TABLE 1. IDENTIFICATION BYTE FORMAT**

Logic values at pins A1, and A0 respectively

|       |   |   |   |   |       |    |     |
|-------|---|---|---|---|-------|----|-----|
| 0     | 1 | 0 | 1 | 0 | A1    | A0 | R/W |
| (MSB) |   |   |   |   | (LSB) |    |     |

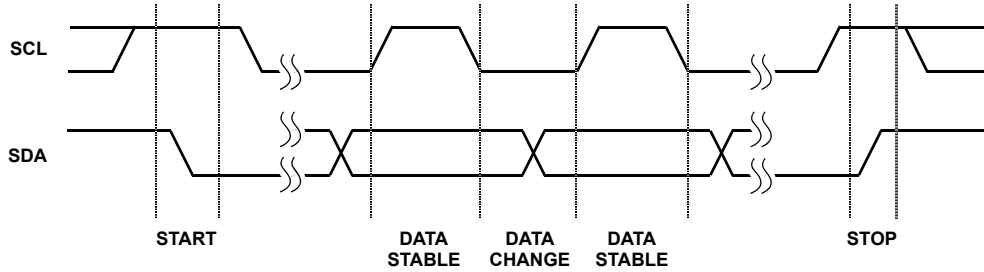

**FIGURE 9. VALID DATA CHANGES, START, AND STOP CONDITIONS**

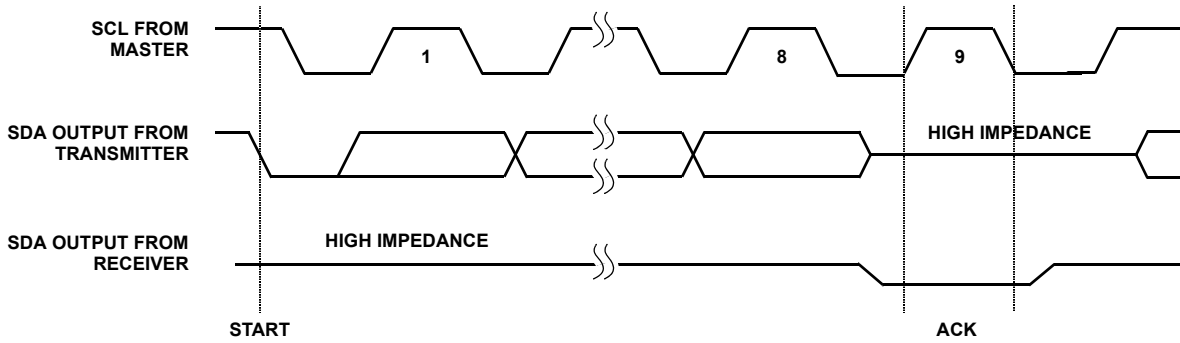

**FIGURE 10. ACKNOWLEDGE RESPONSE FROM RECEIVER**

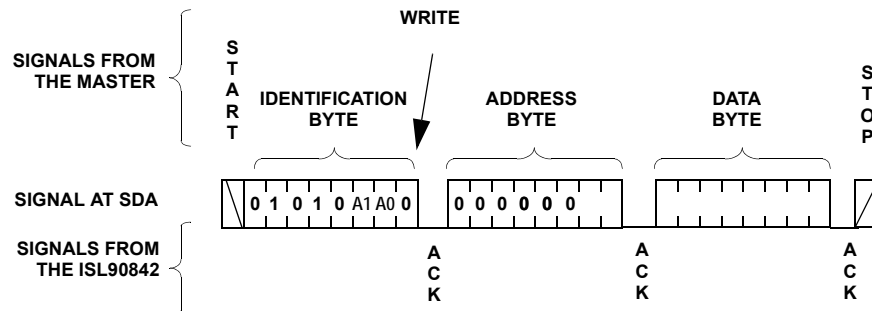

**FIGURE 11. BYTE WRITE SEQUENCE**



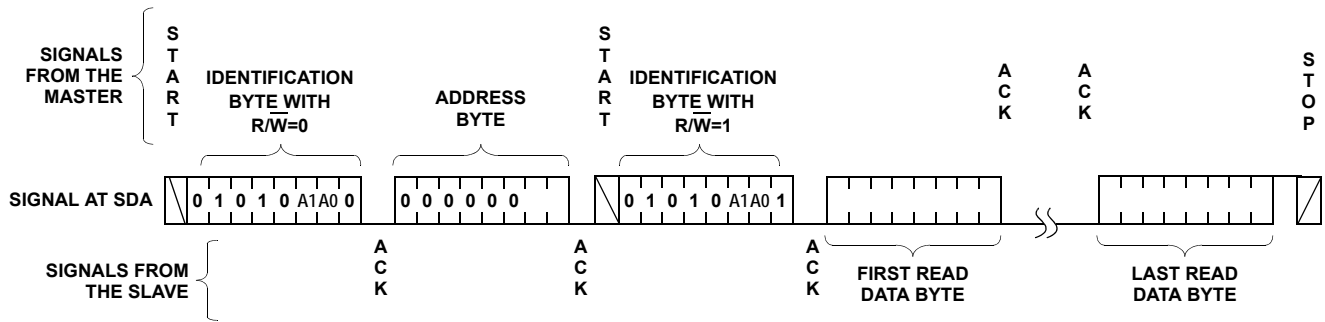

FIGURE 12. READ SEQUENCE

### Write Operation

A Write operation requires a START condition, followed by a valid Identification Byte, a valid Address Byte, a Data Byte, and a STOP condition. After each of the three bytes, the ISL90842 responds with an ACK. At this time, the device enters its standby state (See Figure 11).

### Read Operation

A Read operation consists of a three byte instruction followed by one or more Data Bytes (See Figure 12). The master initiates the operation issuing the following sequence: a START, the Identification byte with the R/W bit set to "0", an Address Byte, a second START, and a second Identification byte with the R/W bit set to "1". After each of the three bytes, the ISL90842 responds with an ACK. Then the ISL90842 transmits Data Bytes as long as the master responds with an ACK during the SCL cycle following the eighth bit of each byte. The master terminates the read operation (issuing a STOP condition) following the last bit of the last Data Byte (See Figure 12).

The Data Bytes are from the registers indicated by an internal pointer. This pointer initial value is determined by the Address Byte in the Read operation instruction, and increments by one during transmission of each Data Byte. After reaching the memory location 03h the pointer "rolls over" to 00h, and the device continues to output data for each ACK received.

© Copyright Intersil Americas LLC 2005-2006. All Rights Reserved.

All trademarks and registered trademarks are the property of their respective owners.

For additional products, see [www.intersil.com/en/products.html](http://www.intersil.com/en/products.html)

Intersil products are manufactured, assembled and tested utilizing ISO9001 quality systems as noted in the quality certifications found at [www.intersil.com/en/support/qualandreliability.html](http://www.intersil.com/en/support/qualandreliability.html)

*Intersil products are sold by description only. Intersil may modify the circuit design and/or specifications of products at any time without notice, provided that such modification does not, in Intersil's sole judgment, affect the form, fit or function of the product. Accordingly, the reader is cautioned to verify that datasheets are current before placing orders. Information furnished by Intersil is believed to be accurate and reliable. However, no responsibility is assumed by Intersil or its subsidiaries for its use; nor for any infringements of patents or other rights of third parties which may result from its use. No license is granted by implication or otherwise under any patent or patent rights of Intersil or its subsidiaries.*

For information regarding Intersil Corporation and its products, see [www.intersil.com](http://www.intersil.com)

**Packaging Information**

**14-Lead Plastic, TSSOP, Package Code V14**

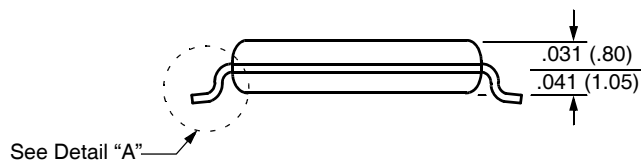
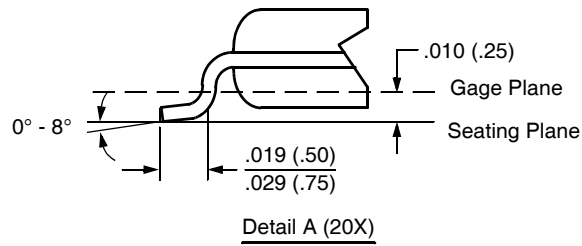
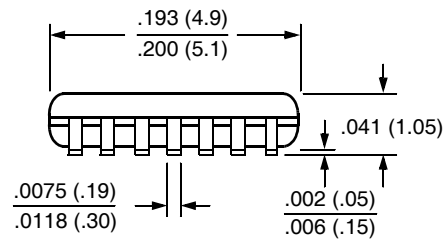
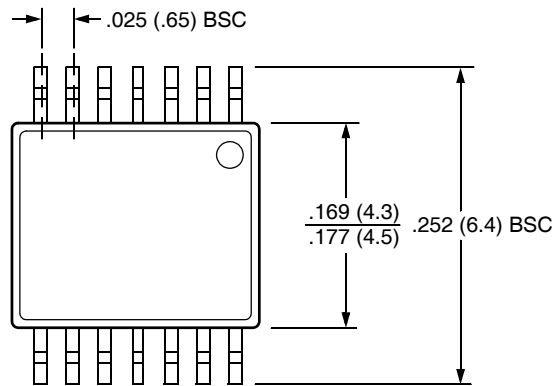

**NOTE: ALL DIMENSIONS IN INCHES (IN PARENTHESES IN MILLIMETERS)**

Компания «Life Electronics» занимается поставками электронных компонентов импортного и отечественного производства от производителей и со складов крупных дистрибьюторов Европы, Америки и Азии.

С конца 2013 года компания активно расширяет линейку поставок компонентов по направлению коаксиальный кабель, кварцевые генераторы и конденсаторы (керамические, пленочные, электролитические), за счёт заключения дистрибьюторских договоров

Мы предлагаем:

- Конкурентоспособные цены и скидки постоянным клиентам.
- Специальные условия для постоянных клиентов.
- Подбор аналогов.
- Поставку компонентов в любых объемах, удовлетворяющих вашим потребностям.
- Приемлемые сроки поставки, возможна ускоренная поставка.
- Доставку товара в любую точку России и стран СНГ.
- Комплексную поставку.
- Работу по проектам и поставку образцов.
- Формирование склада под заказчика.
- Сертификаты соответствия на поставляемую продукцию (по желанию клиента).
- Тестирование поставляемой продукции.
- Поставку компонентов, требующих военную и космическую приемку.
- Входной контроль качества.
- Наличие сертификата ISO.

В составе нашей компании организован Конструкторский отдел, призванный помогать разработчикам, и инженерам.

Конструкторский отдел помогает осуществить:

- Регистрацию проекта у производителя компонентов.
- Техническую поддержку проекта.
- Защиту от снятия компонента с производства.
- Оценку стоимости проекта по компонентам.
- Изготовление тестовой платы монтаж и пусконаладочные работы.



Тел: +7 (812) 336 43 04 (многоканальный)  
Email: [org@lifeelectronics.ru](mailto:org@lifeelectronics.ru)