

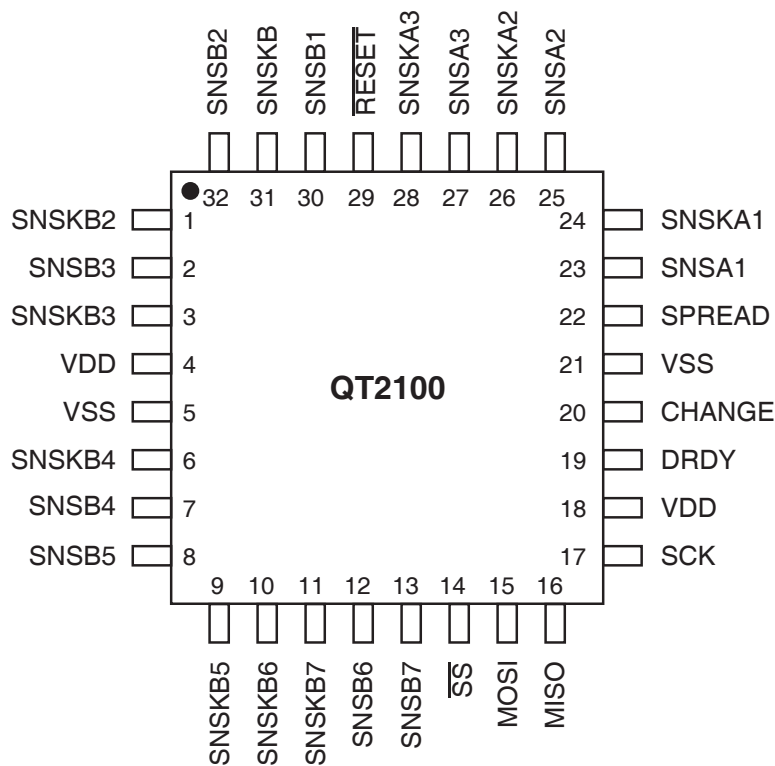
## Features

- **Number of QTouch® Keys:**
  - 0 to 7, one slider or one wheel
- **Technology:**
  - Patented spread-spectrum charge-transfer
- **Key Outline Sizes:**
  - 5 mm x 5 mm or larger (panel thickness dependent); widely different sizes and shapes possible
- **Key Spacing:**
  - 6 mm or wider, center to center (panel thickness, human factors dependent)
- **Key Design:**
  - Single solid or ring shaped electrodes; wide variety of possible layouts
- **Wheel Size:**
  - Typically 30 – 50 mm diameter, resistively interpolated wheel up to 80 mm diameter, typical width 12 mm
- **Slider Size:**
  - Typically 50 – 100 mm length, typical width 12 mm
- **Slider/Wheel Electrode Design:**
  - Choice of spatially interpolated (resistorless) or resistively interpolated design
  - Slider can be an arc or other irregular shape
- **Layers Required:**
  - One layer substrate; electrodes and components can be on same side
- **Substrates:**
  - FR-4, low cost CEM-1 or FR-2 PCB materials; polyamide FPCB; PET films, glass
- **Electrode Materials:**
  - Copper, silver, carbon, ITO, virtually anything electrically conductive
- **Panel materials:**
  - Plastic, glass, composites, painted surfaces (nonconductive paints)
- **Adjacent Metal:**
  - Compatible with grounded metal immediately next to keys
- **Panel Thickness:**
  - For keys, up to 15 mm glass, 10 mm plastic (key size dependent)
  - For slider/wheel, up to 4 mm glass, 3 mm plastic
- **Key Sensitivity:**
  - Adjustable via change in sampling capacitor (Cs) value

- **Interface:**
  - SPI @ 750 kHz, CHANGE and DRDY status indicator pins
- **Moisture Tolerance:**
  - Increased moisture tolerance based on hardware design and firmware tuning
- **Power:**
  - 2.0 V to 5.5 V
- **Signal Processing:**
  - Self-calibration, autodrift compensation, noise filtering, patented Adjacent Key Suppression® (AKS®)
- **Package:**
  - 32-pin 5 x 5 mm MLF RoHS compliant
  - 32-pin 7 x 7 mm TQFP RoHS compliant
- **Applications:**
  - Portable devices, domestic appliances and A/V equipment, PC peripherals, office equipment

# 1. Pinout and Schematic

## 1.1 Pinout Configuration



## 1.2 Pin Descriptions

Table 1-1. Pin Listing

Pin	Name	Type	Function	If Unused, Connect To...
1	SNSKB2	I/O	Sense pin. Connect to any CsB + Key	Open
2	SNSB3 <sup>(1)</sup>	I/O	Sense pin. Connect to CsB3	Open
3	SNSKB3	I/O	Sense pin. Connect to any CsB + Key	Open
4	VDD	P	Power	-
5	VSS	P	Ground	-
6	SNSKB4	I/O	Sense pin. Connect to any CsB + Key	Open
7	SNSB4 <sup>(1)</sup>	I/O	Sense pin. Connect to CsB4	Open
8	SNSB5 <sup>(1)</sup>	I/O	Sense pin. Connect to CsB5	Open
9	SNSKB5	I/O	Sense pin. Connect to any CsB + Key	Open
10	SNSKB6	I/O	Sense pin. Connect to any CsB + Key	Open
11	SNSKB7	I/O	Sense pin. Connect to any CsB + Key	Open
12	SNSB6 <sup>(1)</sup>	I/O	Sense pin. Connect to CsB6	Open

**Table 1-1. Pin Listing (Continued)**

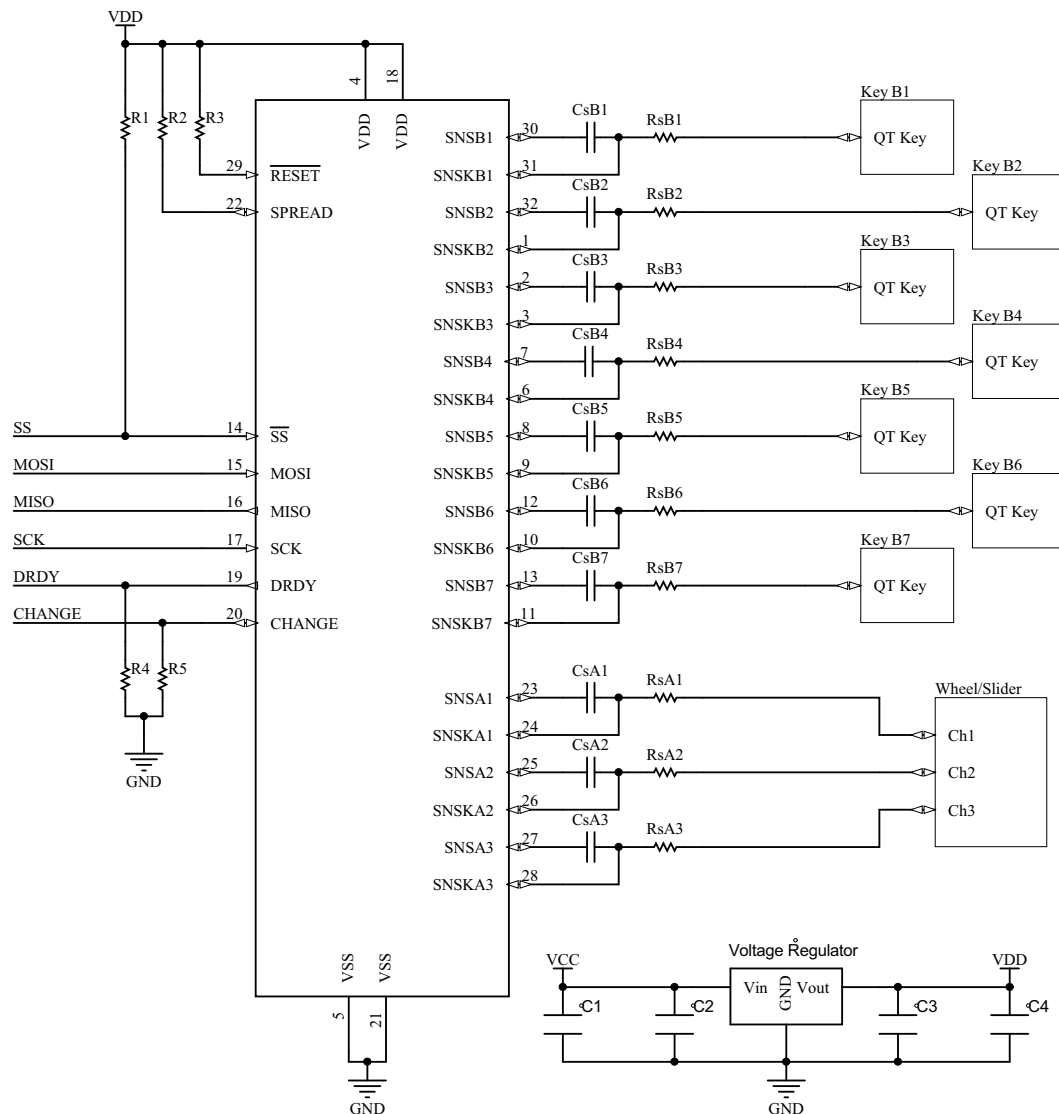
Pin	Name	Type	Function	If Unused, Connect To...
13	SNSB7 <sup>(1)</sup>	I/O	Sense pin. Connect to CsB7	Open
14	$\overline{SS}$	I	SPI Slave Select (active low)	-
15	MOSI	I	SPI Master Out /Slave In	-
16	MISO	OF	SPI Master In/Serial Out	-
17	SCK	I	SPI Clock	-
18	VDD	P	Power	-
19	DRDY	OF	SPI Data Ready handshake line	Open
20	CHANGE	OF	State change notification	Open
21	VSS	P	Ground	-
22	SPREAD	OD	Spread-spectrum drive Connect to Vdd (high) to enable Connect to Vss (low) to disable	-
23	SNSA1 <sup>(1)</sup>	I/O	Sense pin. Connect to CsA1	Open
24	SNSKA1	I/O	Sense pin. Connect to any CsA + slider/wheel	Open
25	SNSA2 <sup>(1)</sup>	I/O	Sense pin. Connect to CsA2	Open
26	SNSKA2	I/O	Sense pin. Connect to any CsA + slider/wheel	Open
27	SNSA3 <sup>(1)</sup>	I/O	Sense pin. Connect to CsA3	Open
28	SNSKA3	I/O	Sense pin. Connect to any CsA + slider/wheel	Open
29	$\overline{RESET}$	I	Reset (active low)	Vdd via resistor
30	SNSB1 <sup>(1)</sup>	I/O	Sense pin. Connect to CsB1	Open
31	SNSKB1	I/O	Sense pin. Connect to any CsB + Key	Open
32	SNSB2 <sup>(1)</sup>	I/O	Sense pin. Connect to CsB2	Open

1. SNS terminals can be paired with any SNSK terminals of the same group. For example, SNSA1 can be paired with any SNSKA terminal.

I/O          CMOS input/output  
 I             CMOS input only  
 OD          CMOS open drain output (pull-up to Vdd)  
 OF          CMOS output that can float during Reset, Sleep or LP modes  
 P            Ground or power

## 1.3 Schematic

Figure 1-1. Connection Diagram (32-MLF Package)



### Important Design Guidelines:

- The sensitivities of the various sense channels are determined by the values of the respective Cs capacitors (that is, CsB1, CsB7, and so on); these values will require adjustment based on building a prototype product and testing the sensitivity experimentally.
- Signals DRDY and CHANGE may need pull-down resistors.

Re [Figure 1-1](#), check the following sections for the variable component values:

- [Section 3.1 on page 9](#): Cs capacitors (CsB)
- [Section 3.2 on page 9](#): Sample resistors (R<sub>SNS</sub>)
- [Section 3.3 on page 9](#): Voltage levels

## 2. Overview

### 2.1 Introduction

The AT42QT2100 (QT2100) is an easy-to-use sensor IC based on the Atmel-patented charge-transfer (QT™) principles for robust operation and ease of design. This device has many advanced features which provide for reliable, trouble-free operation over the life of the product. In particular the QT2100 features advanced self-calibration, drift compensation, and fast thermal tracking. The QT2100 can tolerate some fluctuations in the power supply, and in many applications will not require a dedicated voltage regulator.

The QT2100 is capable of detecting near-proximity or touch on up to seven electrodes and a slider/wheel. It allows electrodes to project sense fields through any dielectric such as glass or plastic. These electrodes are laid out as a scroller (slider or wheel), plus seven additional independent keys.

Each key channel can be tuned for a unique sensitivity level by simply changing a corresponding external Cs capacitor, whereas the slider/wheel sensitivity can be changed dynamically through SPI commands. Any number of key channels can be optimized for operation as hand proximity sensors by increasing the sensitivity for the corresponding channel.

**Note:** There are special conditions if using AKS (see [Section 4.3.6 on page 15](#)).

The slider/wheel uses a simple, inexpensive sensing element between three connection points. The QT2100 can report a single rapid touch anywhere along the sense elements, or it can track a finger moving along the slider/wheel's surface in real time.

By using the charge-transfer principle, this device delivers a level of performance clearly superior to older technologies yet is highly cost-effective. Spread-spectrum burst technology provides superior noise rejection.

### 2.2 Burst Operation

The device operates in burst mode. Each key is acquired using a burst of charge-transfer sensing pulses whose count varies depending on the value of the sense capacitors (CsA1 to CSA3 and CsB1 to CSB7) and the load capacitance Cx (finger touch capacitance and circuit stray capacitance).

The channels' signals are acquired using three successive bursts of pulses:

Burst 1: B1, B2, B3

Burst 2: B4, B5, B6, B7

Burst 3: A1, A2, A3

where B1 to B7 are the individual key sensors and A1 to A3 are the slider/wheel sensors.

Bursts operate in sequence and occur one after the other with minimum delay. During each burst the DRDY pin is held low. The groups are separated by an interval of 500  $\mu$ s when DRDY is held high to signal an appropriate time for SPI communications. Communications may be carried out at any time, however, regardless of the state of the DRDY pin.

### 2.3 User Interface Layout and Options

The QT2100 can sense through all common plastics or glass or other dielectric materials up to 10 mm thick. It can be used to implement a linear slider or rotary scroll wheel plus seven additional discrete keys. The slider or wheel indicates absolute positions.

### 2.4 Slider and Wheel Construction

The QT2100 can be connected to a linear slider element (see [Section 3.5 on page 10](#)) or a wheel. Selection of linear operation or wheel is set through an SPI command.

## 2.5 Proximity Effect

Any number of keys can be programmed to have hand or body proximity. By using a relatively large electrode inside the product enclosure and a larger value of CsB, the product can auto power up or activate its display with hand approach. This simple feature can add enormous sales appeal to almost any product. However, if using AKS see [Section 4.3.6 on page 15](#).

## 2.6 Moisture Tolerance

The presence of water (condensation, sweat, spilt water, and so on) on a sensor can alter the signal values measured and thereby affect the performance of any capacitive device. The moisture tolerance of QTouch devices can be improved by designing the hardware and fine-tuning the firmware following the recommendations in the application note Atmel AVR3002: *Moisture Tolerant QTouch Design* ([www.atmel.com/Images/doc42017.pdf](http://www.atmel.com/Images/doc42017.pdf)).

## 2.7 SPI Interface

The QT2100 is an SPI slave mode device, utilizing a four-wire full-duplex SPI interface.

In addition to the standard four SPI signals ( $\overline{SS}$ , SCK, MOSI and MISO), there is a DRDY (data ready) output which may optionally be used to time communications such that they do not occur during channel measurement bursts. During each burst DRDY is held low by the QT2100. After each group burst, DRDY is driven high for 500  $\mu$ s or until 3 bytes have been exchanged.

The QT2100 also provides a CHANGE signal to indicate when there has been a change in detection state. This removes the need for the host to poll the QT2100 continuously.

On each SPI transfer the host sends three bytes to the QT2100 and the QT2100 simultaneously sends three bytes to the host. The bytes sent from the host provide the QT2100 with all its configuration information; the bytes sent from the QT2100 convey the states of the touch keys and slider or wheel.

## 2.8 Operating Modes

The device features a number of operating modes to set the current drain and speed of response.

The available operating modes are:

- **Free Run Mode**

This mode uses a continuous stream of acquire bursts. Free Run mode has, in consequence, the highest power drain of all the QT2100 operating modes but the fastest response time.

- **LP Mode**

In LP (low power) modes, the QT2100 spends a portion of the time sleeping to conserve power; it wakes itself periodically to perform acquire bursts, then normally goes back to sleep again. The QT2100 provides a choice of intervals between acquire bursts to allow an appropriate trade-off between speed and power to be made for each product.

- **Sleep Mode**

In Sleep mode, the QT2100 shuts down to conserve power; it remains in this mode, carrying out no acquisition bursts until the host wakes it using the  $\overline{SS}$  pin.

- **Sync Mode**

In this mode the device synchronizes to the host in a way that allows for the suppression of heavy low frequency noise; for example, from mains frequencies and their harmonics.



## 3. Wiring and Parts

### 3.1 Cs Sample Capacitors

The Cs (CsA1 to CSA3 and CsB1 to CSB7) sample capacitors accumulate the charge from the key electrodes and determine sensitivity. Higher values of Cs make the corresponding sensing channel more sensitive. The values of Cs can differ for each channel, permitting differences in sensitivity from key to key or to balance unequal sensitivities.

Unequal sensitivities can occur due to key size and placement differences and stray wiring capacitances. More stray capacitance on a sense trace will desensitize the corresponding key; increasing the Cs for that key will compensate for the loss of sensitivity.

The Cs capacitors can be virtually any plastic film or low to medium-K ceramic capacitor. Acceptable capacitor types for most uses include PPS film, polypropylene film, and NP0 and X7R ceramics. Lower grade ceramics than X7R are not advised; the X5R grade should be avoided because it is less stable than X7R. Larger values of Cs require better quality to ensure reliable sensing

The normal Cs range is 1 nF to 100 nF for the keys and 4.7 nF to 220 nF for each channel of the slider or wheel for good performance and position detection. The actual value used depends on the sensitivity required. A 3 nF to 5 nF capacitor is typical for a touch key with an electrode diameter of 10 to 12 mm and a cover of 1 to 2 mm plastic, and approximately 10 nF to 15 nF for slider or wheel electrodes.

### 3.2 Rs Series Resistors

Series Rs resistors (RsA1 to RSA3 and RsB1 to RSB7) are in-line with the electrode connections and are used to limit electrostatic discharge (ESD) currents and to suppress radio frequency interference (RFI). For most applications the Rs resistors will be in the range 4.7 k $\Omega$  to 33 k $\Omega$  each. In a few applications with low loading on the sense keys the value may be up to 100 k $\Omega$ .

Although these resistors may be omitted, the device may become susceptible to external noise or RFI. For details of how to select these resistors refer to Application Note QTAN0079 *Buttons, Sliders and Wheels Sensor Design Guide*.

### 3.3 Power Supply

The power supply can range from 2.0 V to 5.5 V. If this fluctuates slowly with temperature, the device will track and compensate for these changes automatically with only minor changes in sensitivity. If the supply voltage drifts or shifts quickly, the drift compensation mechanism will not be able to keep up, causing sensitivity anomalies or false detections. In this situation a dedicated voltage regulator should be included in the circuit.

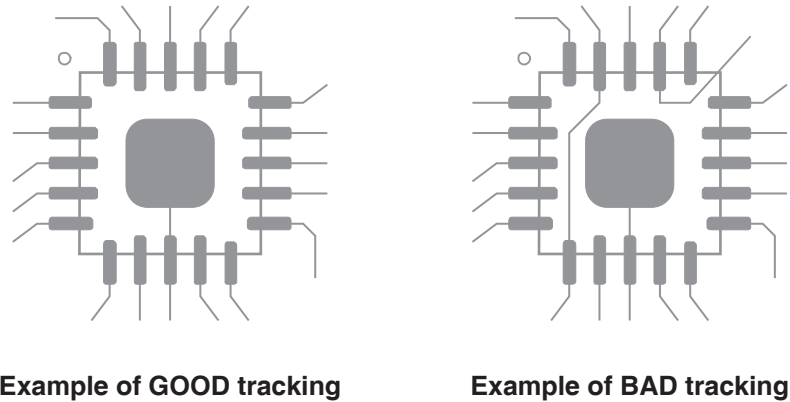
The QT2100 power supply should be locally regulated using a three-terminal device, to between 2.0 V and 5.5 V. If the supply is shared with another electronic system, care should be taken to ensure that the supply is free of digital spikes, sags, and surges, all of which can cause adverse effects.

For proper operation a 0.1  $\mu$ F, or greater, bypass capacitor must be used between Vdd and Vss; the bypass capacitor should be routed with very short tracks to the QT2100 VSS and VDD pins.

### 3.4 MLF Package Restrictions

The central pad on the underside of the MLF chip should be connected to ground. Do not run any tracks underneath the body of the chip, only ground. [Figure 3-1](#) shows an example of good and bad tracking.

**Figure 3-1. Examples of Good and Bad Tracking**

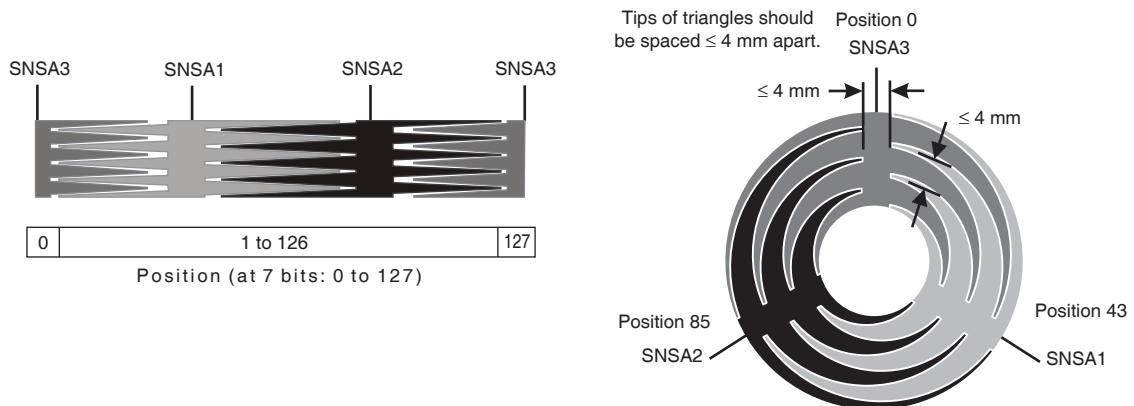


### 3.5 Slider and Wheel Construction

The QT2100 can be connected to a linear slider element or a wheel (see [Figure 3-2](#)). Selection of linear slider operation or a wheel is set through an SPI command.

As with touch button electrodes, sliders and wheels can be constructed as etched areas on a PCB or flex circuit, or from clear conductors such as Indium Tin Oxide (ITO) or screenprinted PEDOT to allow backlighting effects, or for use over an LCD display.

**Figure 3-2. All-Metal Slider and Wheel Construction**  
(Downloadable CAD files can be found on the Atmel website)



### 3.6 Oscillator

No external oscillator is needed.

### 3.7 PCB Layout and Construction

Refer to Application Note QTAN0079, *Buttons, Sliders and Wheels Sensor Design Guide* and the *Touch Sensors Design Guide* (both downloadable from the Atmel website), for more information on construction and design methods.

The sensing channels used for the individual keys can be implemented as per the *Touch Sensors Design Guide*.

### 3.8 PCB Cleanliness

Modern no-clean-flux is generally compatible with capacitive sensing circuits.



**CAUTION:** If a PCB is reworked to correct soldering faults relating to the QT2100, or to any associated traces or components, be sure that you fully understand the nature of the flux used during the rework process. Leakage currents from hygroscopic ionic residues can stop capacitive sensors from functioning. If you have any doubts, a thorough cleaning after rework may be the only safe option.

### 3.9 Spread-spectrum Circuit

The QT2100 offers the ability to spectrally spread its frequency of operation to heavily reduce susceptibility to external noise sources and to limit RF emissions.

With this option enabled, bursts operate over a spread of frequencies, so that external fields will have minimal effect on key operation and emissions are very weak. Spread-spectrum operation works together with the Detect Integrator (DI) mechanism to dramatically reduce the probability of false detection due to noise.

Spread spectrum may be enabled by connecting the SPREAD pin to Vdd via a pull-up resistor, or disabled by connecting to Vss via a pull-down resistor.

## 4. Detailed Operation

### 4.1 Reset

#### 4.1.1 Introduction

When starting from power-up or  $\overline{\text{RESET}}$  reset there are a few additional factors to be aware of. In most applications the host will not need to take special action.

During hardware reset all outputs are disabled. To define the levels of the CHANGE and DRDY during reset these signals should be pulled down by resistors to 0 V. Otherwise, they may drift high causing the host to detect a false logic 1.

When the initial reset phase ends, CHANGE and DRDY outputs are enabled. DRDY will drive low and CHANGE will drive high.

#### 4.1.2 Delay to SPI Functionality

The QT2100 SPI interface is not operational while the device is being reset. However, SPI is made operational early in the start-up procedure.

After any reset (either via the  $\overline{\text{RESET}}$  pin or via power-up), SPI typically becomes operational within 50 ms of  $\overline{\text{RESET}}$  going high or power-up. CHANGE is pulled high, and held high until the device status is read by the host microcontroller, to indicate completion of the initialization sequence after power-on or reset.

#### 4.1.3 Reset Delay to Touch Detection

After power-up or reset, the QT2100 calibrates all electrodes.

During this time, touch detection cannot be reported. Calibration completes after 15 burst cycles, which takes approximately 350 ms, depending on the electrode layout and Cs selection.

In total, 400 ms are required from reset or power-up for the device to be fully functional.

#### 4.1.4 Disabled Keys:

Keys with missing Cs capacitors, or that otherwise have an out-of-range signal during calibration, are considered to be unused or faulty and are disabled. Disabled keys are re-examined for operation after each reset or recalibration event.

#### 4.1.5 Mode Setting After Reset

After a reset the device will enter Free Run mode, with AKS disabled.

## 4.2 Communications

### 4.2.1 Introduction

The QT2100 communicates as a slave device over a full-duplex 4-wire (MISO, MOSI, SCK,  $\overline{\text{SS}}$ ) SPI interface. In addition there is a DRDY pin which indicates when the QT2100 is carrying out acquisition bursts and a CHANGE pin which is asserted when a change occurs in the status of the touch sensors (see [Table 4-1](#)).

**Table 4-1. Additional Pins**

Pin	High	Low
DRDY	Burst is complete	Burst is active
CHANGE	New touch data	Latest data has already been read by host

See [Section 6.5 on page 32](#) for details of the SPI Configuration and Timing Parameters.

The host must always transfer three bytes in succession within the allotted time (10 ms maximum). If all bytes are not received in this interval it is treated by the QT2100 as an error. In this case the exchange is reset and the next read will contain the first data byte of a new exchange.

Messages from the host to the QT2100 carry configuration information; return data from the QT2100 carries key state information. For details of the message contents see [Section 5. on page 19](#).

[Figure 6-1](#) and [Figure 6-2 on page 33](#) show the basic timing for SPI operation. The host does the clocking and controls the timing of the transfers from the QT2100. Transfers are always clocked as a set of three bytes, Byte 1, 2, and 3.

DRDY stays high for 500  $\mu$ s. It falls again after Byte 3 has shifted to indicate completion. DRDY goes high after each burst.

After the host asserts  $\overline{SS}$  low, it should wait >22  $\mu$ s in low power mode before starting SCK; in Free run mode, a delay of 2  $\mu$ s is sufficient. The QT2100 reads the MOSI pin with each rising edge of SCK, and shifts data out on the MISO pin on falling edges. The host should do the same to ensure proper operation.

Between the end of the Byte 1 shift and the start of the Byte 2 shift (and between Byte 2 and Byte 3), the host may raise  $\overline{SS}$  again, but this is not required.  $\overline{SS}$  should be held high when not communicating; if  $\overline{SS}$  is low this is taken as an indication of impending communications.

In this case, extra current is drawn, as the QT2100 does not enter its lowest power sleep mode.

All timings not mentioned above should be as in [Figure 6-2 on page 33](#).

#### 4.2.2 Change Pin

The QT2100 has a CHANGE output pin which allows for key state change notification. Use of the CHANGE signal relieves the host of the burden of regularly polling the QT2100 to get key states. CHANGE goes high when an event occurs that causes a change to the contents of the *Normal Data* bytes; that is, when a new key is pressed, or released, or a movement is detected on the slider/wheel.

Similarly, when a custom threshold or LPM is sent to the QT2100, the CHANGE line is asserted to indicate that the new setting has been applied and is shown in the *Normal Exchange* data.

CHANGE also goes high after a reset to indicate to the host that it should do an SPI transfer in order to provide initial configuration information to the QT2100 (as it does on every SPI transfer).

CHANGE is driven low only once the data has been read through an SPI transfer.

In the case of a transient touch on one of the sensors, in which the touch has been removed before the host has read the status of the sensors, the Change line remains asserted.

**Note:** In this case the data that will be read may be identical to the data that was previously read.

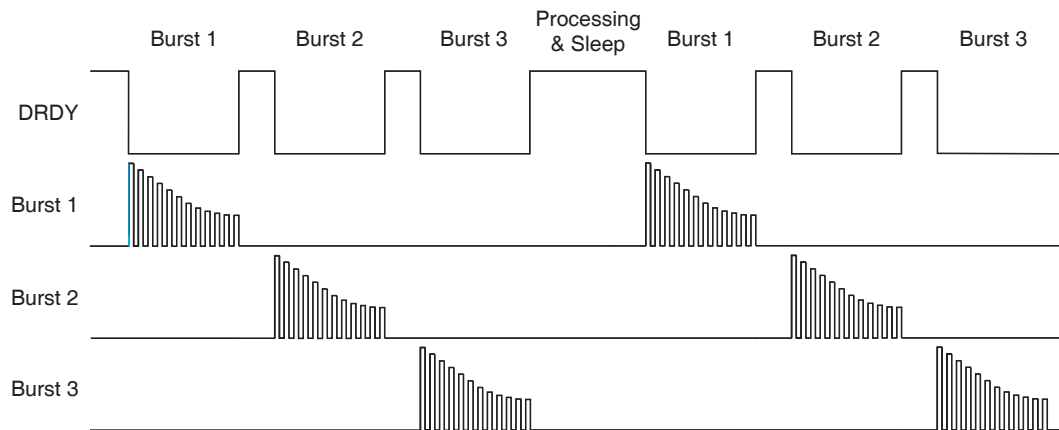
#### 4.2.3 DRDY Pin

The Data Ready (DRDY) pin is a quick indication of the QT2100 activity. During channel acquisition bursts the pin is held low by the device, and driven high for ~500  $\mu$ s in between bursts. During processing and sleep the pin is driven high continuously, unless a 3-byte communications exchange has taken place since the last acquisition burst.

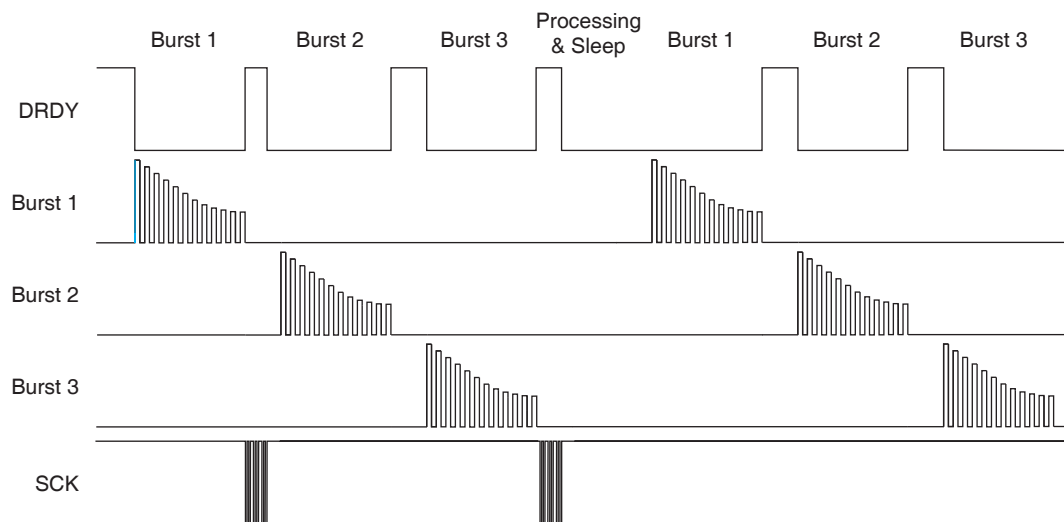
After a 3-byte exchange has completed the pin is pulled low and remains low until the next burst completion, after which the normal cycle resumes. This allows the host to detect if the 3-byte exchange packets have become de-synchronized.

The QT2100 has a DRDY grace period. If communications start during the 20  $\mu$ s after DRDY has been deasserted (pulled low) by the QT2100, then DRDY is reasserted and held high until the exchange is complete. Key measurement bursts do not take place during this time.

**Figure 4-1. DRDY Cycle without Communications**



**Figure 4-2. DRDY Cycle with Communications**



## 4.3 Signal Processing

### 4.3.1 Power-up Self-calibration

On power-up, or after reset, all 10 channels are typically calibrated and operational within 350 ms.

### 4.3.2 Drift Compensation

This operates to correct the reference level of each key automatically over time; it suppresses false detections caused by changes in temperature, humidity, dirt and other environmental effects.

The QT2100 drifts *towards touch* at a rate limited to 1 count every 3 seconds, and *away from touch* at a rate limited to 1 count every 0.5 s. Reference drift is paused during touch detection, and for 2 s after touch detection ends. These timings may be slower in *Sync* mode, or where asynchronous acquisition is triggered with LPB, as timing calculations are derived from the acquisition interval.

### 4.3.3 Detection Integrator Filter

Detect Integrator (DI) filter confirmation reduces the effects of noise on key states. The DI mechanism requires a specified number of measurements that qualify as detections (and these must occur in a row) or the detection will not be reported.

In a similar manner, the end of a touch (loss of signal) also has to be confirmed over several measurements.

The QT2100 provides a choice of either two or six DI measurements.

### 4.3.4 Adjacent Key Suppression (AKS)

This patented feature works to prevent multiple keys from incorrectly responding to a single touch. This can happen with closely spaced keys, or a scroll wheel that has buttons very near.

Adjacent Key Suppression (AKS) operates by comparing signal strengths from keys within a group of keys to suppress touch detections from those that have a weaker signal change than the dominant one.

When enabled globally on the QT2100, AKS allows only one key or the scroll section to indicate a touch at a time. The QT2100 has a range of preset AKS groupings, where only one key in an AKS group can indicate a touch at any time while keys in different groups can indicate touch in any combination.

AKS can also be disabled.

### 4.3.5 Autorecalibration (MOD)

The device can time out and recalibrate all sensors after a continuous touch detection that lasts for the chosen Maximum On Duration (MOD). This ensures that a key can never become *stuck on* due to foreign objects or other external influences. After recalibration the key will resume normal functionality.

The nominal delay is selectable to be 10 s, 20 s, 60 s, or infinite (disabled) though the actual delay is different in Sleep mode, as timing is entirely driven by host communications.

The device also automatically recalibrates a key when its associated signal reflects a sufficient decrease in capacitance from the reference level (signal error). In this case, unlike MOD recalibration, only the key that shows a signal error is recalibrated.

This recalibration is triggered when the decrease in capacitance is seen on the key signal for more than 1.5 s.

### 4.3.6 Proximity Sensor

Any key can be optimized for operation as a hand proximity sensor. The sensitivity can be increased by a higher value of Cs.

However, if using AKS only channel seven can be used as a proximity sensor and the AKS bits should be set to 101, to ensure that the proximity key does not lock out other keys or the slider/wheel (see [Table 5-2 on page 20](#)).

Design of proximity electrodes requires care, so as to ensure that the electrode area is maximized whilst ensuring adequate and easy coupling to a hand as it approaches the equipment.

### 4.3.7 Faulty and Unused Keys

Any sense channel that does not have its sense capacitor (Cs) fitted is assumed to be either faulty or unused. A sensor fault is detected by an out-of-range signal count during calibration, where the minimum allowed signal is 32 counts and the maximum is 8192. This channel takes no further part in operation unless a host-commanded recalibration operation shows it to have an in-range burst count again.

This is important for sense channels that have an open or short circuit fault across Cs. Such channels would otherwise cause very long acquire bursts, and in consequence would slow the operation of the device. Note that acquisition pulses will still be generated on these channels, but no measurements of their state will be carried out. The burst will finish when all the enabled channels on the burst group have completed acquisition.

## 4.4 Operating Modes

### 4.4.1 Introduction

Four basic operating modes are possible: **Free Run**, **Low Power (LP)**, **Sleep** and **Sync**. Sleep is a special case of LP mode, where the sleep time is infinite. Sync is a special case of LP mode where the timing of host communications is used as the timing basis for the QT2100 acquisition cycle. In the absence of host communications, the device operates in its most power-efficient low power mode, LP Mode 4. See below for further details.

### 4.4.2 Free Run Mode

In this mode the device operates continuously with short intervals between burst groups; there are three bursts, one burst for each electrode group. DRDY goes high for approximately 500  $\mu$ s between bursts and stays high during signal processing.

In this mode, the acquisition bursts are unsynchronized, making this mode unsuitable if synchronization to mains frequency is needed.

### 4.4.3 Low Power Mode

LP mode is designed to allow low power operation while still retaining full operation but at a slower speed. This mode is useful for devices that must use the touch keys to wake up a product, yet minimize power consumption.

Several LP timings allow the user to trade power versus response time: the slower the response time, the lower the power consumed.

In LP mode, the device spends a portion of the time sleeping between bursts; it wakes periodically to measure all channels with a set of three acquisition bursts, then goes back to sleep.

If a touch is detected, the device operates as in Free Run mode and attempts to perform the Detect Integrator (DI) noise filter function to completion; if the DI filter fails to confirm a detection the device goes back to sleep and resumes LP mode. During the DI function the LPS bit will be cleared.

If a key is found to be in detection the CHANGE pin will go high and the part will remain in Free Run mode. To go back into LP mode the host has to request LP mode again with an SPI communications exchange after the touch detection has been cleared by removal of touch or recalibration.

**CHANGE Pin in LP Mode:** During the sleep portion of LP mode, CHANGE is held low.

If however a change of key state is confirmed, CHANGE goes high and the part runs from then on in Free Run mode until the host reads the key state and puts the device back into LP mode or some other mode.

**MISO in LP Mode:** During the sleep portion of LP mode, MISO floats.

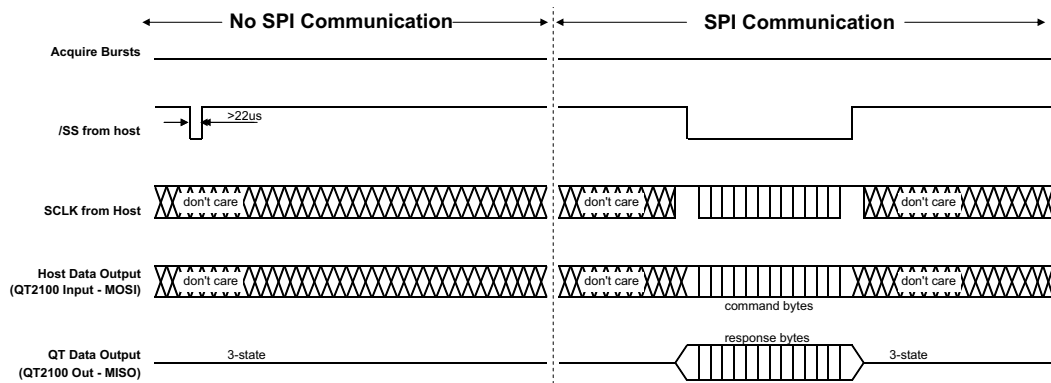
**DRDY during LP Mode:** DRDY remains high while the QT2100 is sleeping, to indicate to the host that SPI communications are possible. During an actual acquire burst, DRDY is held low.

**Command During LP Mode:** The device can be woken from sleep by the  $\overline{SS}$  pin being pulled low. Note that the  $\overline{SS}$  pin must be pulled high in order for the device to enter its lowest power sleep mode. If  $\overline{SS}$  is held low, the device enters a higher power sleep mode to enable SPI communications. The host may perform a normal SPI transfer as shown in [Figure 4-3 on page 17](#).

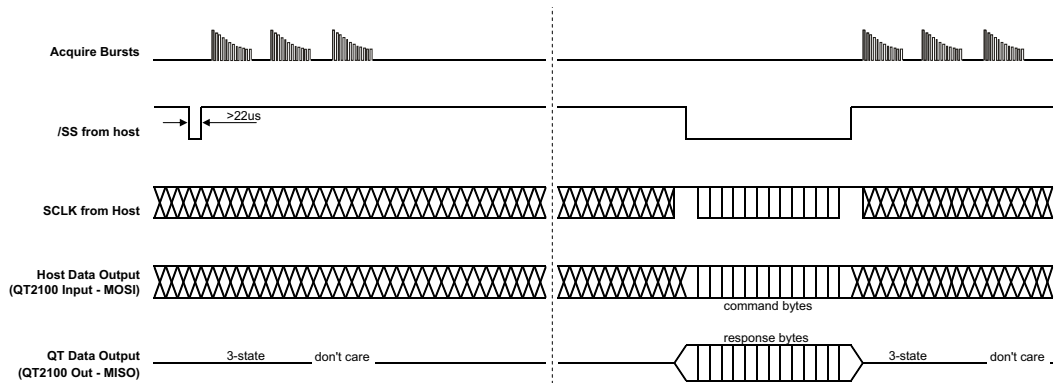


Figure 4-3. LP Mode SPI Operation

SPI Operation with LPB = 0



SPI Operation with LPB = 1



Note: With LPB = 1, a pulse on  $\overline{SS}$  with or without communications triggers an acquisition burst to follow communications. Pulse width > 22  $\mu$ s.

After the SPI transfer is completed, the QT2100 will generate a set of three acquire bursts if LPB = 1, during which DRDY will be low.

The mode and options settings sent from the host to the QT2100 during the SPI transfer take effect after the set of acquire bursts.

- If either LP mode or Sleep mode is selected, the QT2100 will go back to sleep with DRDY high provided no key is detected as possibly touched.
- If Sync mode is selected, the QT2100 will go back to sleep with DRDY high provided no key is detected as possibly touched.

The CHANGE pin will go high at this time if a key is confirmed as touched.

**SS Wake pulse:** In LP Mode, a wake pulse may be used on the  $\overline{SS}$  pin to either trigger an LPB acquire burst or to wake the device in advance of communications. The pulse should be at least 22  $\mu$ s in duration.

When used prior to communications, there should be a delay of 100  $\mu$ s to 1 ms between the end of the  $\overline{SS}$  Pulse and the following  $\overline{SS}$  assertion.

#### 4.4.4 Sleep Mode

Sleep mode offers the lowest possible current drain, in the low microamp region.

Sleep mode is a special case of LP mode, where the sleep duration between bursts is infinite. All comments concerning LP mode, including about SPI communications, apply equally to Sleep mode, except that the LPB bit is ignored and bursts are always generated after an SPI transfer or  $\overline{SS}$  wake pulse as if LPB = 1.

**Note:** In Sleep mode the QT2100 only performs acquisition bursts following being woken by  $\overline{SS}$ . This has two effects:

- Touch detection only occurs following  $\overline{SS}$ -wake pulses, and hence CHANGE can only go high at that time.
- The QT2100 cannot drift its internal references unless the host sends periodic  $\overline{SS}$ -wake pulses. If the host does not do this, then it should command the QT2100 to recalibrate when it sets the QT2100 into a different operating mode.

This mode can be used by the host to create its own LP Mode timings via the  $\overline{SS}$  wakeup pulse method.

#### 4.4.5 Sync Mode

This mode is useful for low frequency noise suppression, for example from mains frequencies in line-operated appliances. Acquisition bursts are synchronized to the  $\overline{SS}$ -wake pulses from the host.

Sync mode is very similar to LP Mode 4, with two differences:

- It does not operate as in Free Run mode when a touch is first detected
- The LPB bit is ignored and a burst is always generated after each  $\overline{SS}$  wakeup or SPI transfer as if LPB = 1

Not operating as in Free Run mode when a touch is first detected (before DI confirmation has taken place) means that acquisition bursts are restricted to the immediate time after a sync signal ( $\overline{SS}$ ), heightening the effect of low frequency noise suppression.

In many applications of Sync mode the DI filter will need to be set to two counts, to avoid the QT2100 response time being unacceptably lengthened as a consequence of this.

## 5. SPI Commands

### 5.1 Introduction

Each communication exchange between the QT2100 and the host device consists of 3 bytes transmitted each way. The host controls the clock signals and the timing of the exchange.

The data sent by the host indicates the command mode and the device settings where appropriate. There are four command modes, selectable through bits 5 – 7 of the first byte (byte 0, Req bits):

- *Normal Exchange* mode (Req = 000)
- *Custom Threshold* command mode (Req = 100)
- *Send Signal* command mode (Req = 001)
- *Device Version* command mode (Req = 010)

The device settings sent by the host in its three command bytes becomes effective immediately after all three bytes are received by the QT2100. The response to these three bytes is three data bytes containing key detection information.

### 5.2 Normal Exchange Mode

#### 5.2.1 Introduction

The **Normal Exchange** mode (Req = 000) is the normal mode for communication between the host and the device. Data is sent every time an SPI communication occurs in Normal Exchange mode. If one of the other commands is sent by the host, the corresponding response will be sent during the subsequent 3-byte exchange.

This Normal Exchange response forms the default (start-up) QT2100 data.

#### 5.2.2 Host Data

In Normal Exchange mode (Req = 000) the host sends the 3-byte data in [Table 5-1](#).

**Table 5-1. Normal Exchange Mode – Host Command Bytes**

Host Byte	Bit							
	7	6	5	4	3	2	1	0
0	Req = 000			PROX	SLD	AKS		
1	0	MOD		DI	LPB	LP Mode		
2	Resolution			CalW	CalK	Cal Key Num		
Note: Bits labelled 0 should not be altered								

## Byte 0

**AKS** – Three bits used to determine the AKS mode, as shown in [Table 5-2](#) (see [Section 4.3.4](#) on page 15 for further information).

**Table 5-2. AKS Mode**

AKS Bits	AKS Option
000	AKS disabled ( <b>default</b> )
001	AKS global: All 7 keys + slider/wheel are in the same group
010	AKS group 1: all keys AKS group 2: slider/wheel
011	AKS group 1: keys 1 – 4 AKS group 2: keys 5 – 7 AKS group 3: slider/wheel
100	AKS group 1: keys 1 – 4 AKS group 2: keys 5 – 7 + slider/wheel
101	AKS group 1: keys 1 – 6 + slider/wheel AKS group 2: key 7

**SLD** – Scrolling device type selection.

SLD = 0: Wheel mode (default)

SLD = 1: Linear slider mode

**PROX** – This setting is included to ensure compatibility with host drivers designed for the QT1106. Any key may be optimized as a proximity sensor but key 7 should be used in any application where AKS is required, as it can be excluded from AKS by selecting AKS mode 101.

**Req** – Set to 000 to indicate Normal Exchange mode.

## Byte 1

**LP Mode** – After each measurement and processing cycle the device goes to sleep for a period, the duration of which is set by the LP mode as per [Table 5-3](#).

**Table 5-3. Sleep/Low Power Modes**

LP Mode Bits	Operating Mode
000	<b>Free run – 0 ms sleep period in each cycle (default):</b> Acquisition and processing carried out continuously with no sleep. This mode has the highest power consumption, but the quickest response.
001	60 ms sleep period in each cycle
010	120 ms sleep period in each cycle
011	240 ms sleep period in each cycle
100	480 ms sleep period in each cycle

**Table 5-3. Sleep/Low Power Modes (Continued)**

LP Mode Bits	Operating Mode
101	<b>Sync mode:</b> The QT2100 performs an acquisition burst when triggered by a rising edge on $\overline{SS}$ and 'heartbeat' bursts at the same interval as LP Mode 4
110	<b>Sleep:</b> The QT2100 performs an acquisition and processing cycle only when triggered by a rising edge on $\overline{SS}$ , whether a low pulse or a communication exchange.
111	Reserved

**LPB** – Sets the LP mode *following burst* option. See [Figure 4-2 on page 14](#).

**LPB = 0:** If the host communicates with the device, or there is an  $\overline{SS}$  pulse during any LP mode (modes 001 to 100), there will be no following burst. The only bursts that will take place are those that occur as naturally defined by the LP mode noted above.

**LPB = 1:** If the host communicates with the device, or there is an  $\overline{SS}$  pulse during any LP mode (modes 001 to 100), there will be an additional burst following  $\overline{SS}$  raising high (**default**).

In modes 101 (Sync) and 110 (Sleep), there will always be a burst following  $\overline{SS}$  raising high, regardless of the LPB Setting. See [Table 5-3](#) for a description of the Mode settings.

**DI** - Set the Detect Integrator noise filter function.

**DI = 0:** Two detections required to confirm a touch (faster but less noise immune).

**DI = 1:** Six detections required to confirm a touch (slower but more noise immune; appropriate for most applications) (default).

**MOD (Recal Time)** – Sets the *Maximum On-duration* for all keys and slider/wheel. Controls the time from the start of a detection to automatic recalibration of all channels. See [Table 5-4](#) for allowed MOD times.

**Table 5-4. Maximum On-duration in Free Run Mode**

MOD Bits	Maximum On-duration
00	10 s ( <b>default</b> )
01	20 s
10	60 s
11	Infinite MOD – timeout disabled

**Note:** in Sleep mode, all device timing is dependent on the regularity of SPI communications. See [Section 4.4.4 on page 17](#) for more information.

## Byte 2

**Cal Key Num** – key to be recalibrated when **CalK = 1** (see [Table 5-5](#)).

**Table 5-5. Key Recalibration**

Cal Key Num Bits	Key
000	Recalibrate all keys (excluding slider/wheel)
001	Recalibrate Key 1
010	Recalibrate Key 2
011	Recalibrate Key 3
100	Recalibrate Key 4
101	Recalibrate Key 5
110	Recalibrate Key 6
111	Recalibrate Key 7

**CalK** – Recalibrates the key(s) specified by **Cal Key Num**.

**CalK = 0:** No recalibration (normal state of this bit).

**CalK = 1:** The device recalibrates key(s).

**CalW** – Recalibrates the slider/wheel.

**CalW = 0:** No recalibration (normal state of this bit).

**CalW = 1:** The device recalibrates the slider/wheel.

Set CalK/CalW only once when required, and set CalK/CalW = 0 thereafter. If the bit is constantly set to 1, the device will keep recalibrating and will never detect a touch.

Note that the device recalibrates automatically on power-up, so that the use of Recal should rarely be required. Any channel used as a proximity detector should be recalibrated soon after each proximity detection, to ensure stability.

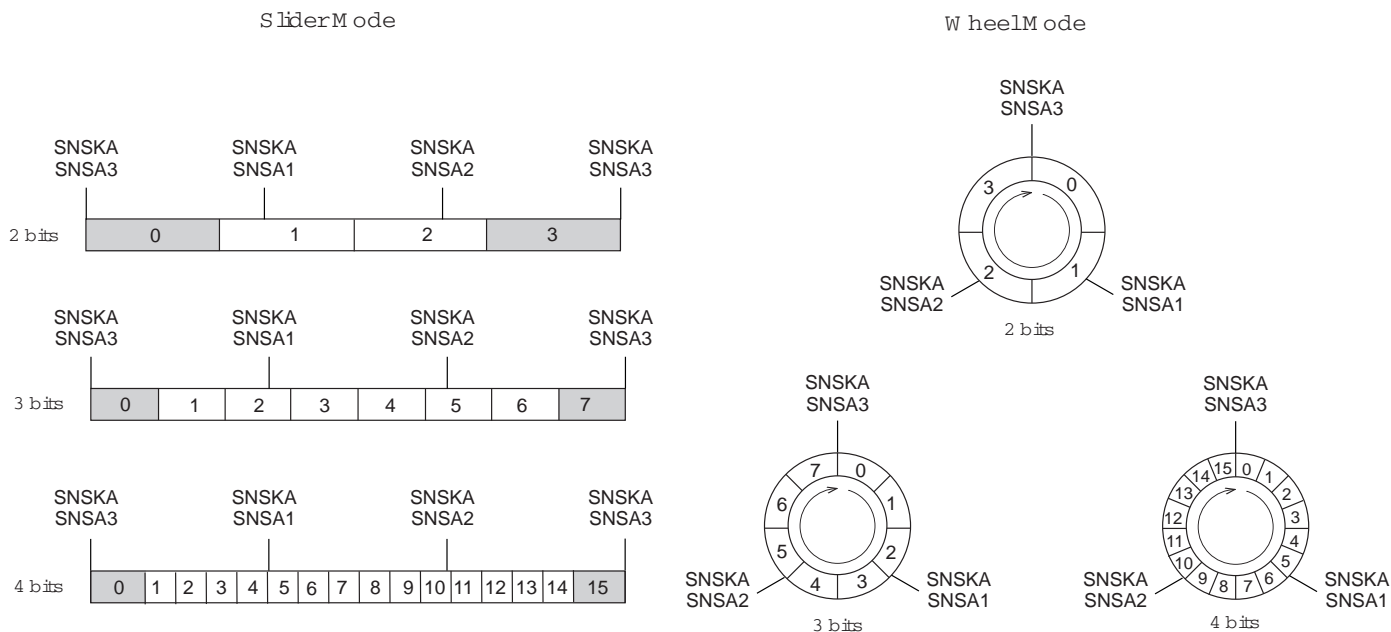
**Resolution** – the resolution of the slider/wheel reported position (see [Table 5-6](#) and [Figure 5-1](#)).

**Table 5-6. Resolution**

Resolution Bits	Resolution
000	Reserved
001	2 Bits: 4 positions (0 – 3)
010	3 Bits: 8 positions (0 – 7)
011	4 Bits: 16 positions (0 – 15)
100	5 Bits: 32 positions (0 – 31)
101	6 Bits: 64 positions (0 – 63)
110	7 Bits: 128 positions (0 – 127) ( <b>default</b> )
111	8 Bits: 256 positions (0 – 255)

**Note:** A resolution change will only become effective on the next touch.

**Figure 5-1. Slider and Wheel Resolution**



Note: the first and last slider positions (shaded) have larger touch areas.

### 5.2.3 QT2100 Data

The three return bytes contain the response to the previously sent command. Initially it is assumed that the previously sent command was a *Normal Exchange* command. The return bytes for the *Normal Exchange* command is shown in Table 5-7.

**Table 5-7. Normal Exchange Mode – Return Bytes**

QT2100 Byte	Bit							
	7	6	5	4	3	2	1	0
0	CW	CK	EW	EK	LPS	PM	0	CTL
1	W	K7	K6	K5	K4	K3	K2	K1
2	Position							

#### Byte 0

**CTL: Custom Threshold Loaded:** If CTL = 1, a custom slider/wheel threshold has been loaded from the host. This is set as a result of a Custom Threshold command. Once the QT2100 has received a custom threshold, this bit is set and stays set until reset.

**PM: Proximity Mode:** This setting is disabled as there is no proximity mode on the QT2100 because each key can be configured as a proximity sensor. This setting has been left to ensure compatibility with the QT1106.

**LPS: LP/Sleep State:** If LPS = 1, the device was in LP, Sync, or Sleep mode when the requesting command was received. If LPS = 0, the device was in Free Run mode.

**EK: Key(s) in Error:** If  $EK = 1$ , there is a sufficient decrease in capacitance of one or more normal key(s) from the reference level. The affected key will be recalibrated if this condition is seen for more than 1.5 seconds.

**EW: Slider/Wheel in Error:** If  $EW = 1$ , there is a sufficient decrease in capacitance of the slider/wheel from the reference level. The slider/wheel will be recalibrated if this condition is seen for six successive cycles.

**CK: Key(s) in Calibration:** If  $CK = 1$ , one or more key(s) are being calibrated.

**CW: Slider/Wheel in Calibration:** If  $CW = 1$ , the slider/wheel is being calibrated.

#### Byte 1

**K1 – K7:** Contains the key states of each key. A 1 in a bit position means the key is confirmed as being touched.

**W:** The state of the wheel/rotor. A 1 means the slider/wheel is confirmed as being touched.

#### Byte 2

**Position:** The position of touch on the slider/wheel. If the slider/wheel is not being touched, the position will be the position of the last touch.



## 5.3 Custom Threshold

### 5.3.1 Introduction

The **Custom Threshold** command mode (Req = 100) is used to modify the detection threshold of the slider/wheel. It only needs to be sent once, for the new value to take effect, and then the Normal Exchange mode resumes (see [Section 5.2 on page 19](#)). The new value will be in use until the chip is reset or a new custom threshold is sent.

### 5.3.2 Host Data

In Custom Threshold command mode the host sends the 3-byte data in [Table 5-8](#).

**Table 5-8. Custom Threshold Command Mode – Host Command Bytes**

Host Byte	Bit							
	7	6	5	4	3	2	1	0
0	Req = 100			0	0	0	0	0
1	T1 – Slider/Wheel Threshold							
2	0	0	0	0	0	0	0	0

Note: Bits labelled 0 should not be altered

#### Byte 0

**Req** – Set to 100 to indicate Custom Threshold command mode.

#### Byte 1

**T1**: Custom threshold value of the slider/wheel. Higher numbers are less sensitive. Touch detection uses this threshold combined with a hysteresis equal to 25% of the threshold (with a minimum hysteresis value of one).

**Power-up default setting:** 30

**Note:** Custom Threshold Command is only used if the detection threshold of the slider/wheel needs to be changed from the power-up default.

#### Byte 2

Always set to 0.

### 5.3.3 QT2100 Data

The QT2100 response to the Custom Threshold command is the Normal Exchange report.

Once the custom thresholds have been set, the CTL bit in the Normal Exchange report is set to 1 to indicate that the changed threshold has been applied (see [Table 5-7](#)).

## 5.4 Send Debug Data

### 5.4.1 Introduction

In a **Send Debug Data** exchange (Req = 001) the host requests the QT2100 to send 16-bit debug data on the next 3-byte exchange.

### 5.4.2 Host Data

In Send Debug Data command mode the host sends the 3-byte data in [Table 5-9](#).

**Table 5-9. Send Debug Data Command Mode – Host Command Bytes**

Host Byte	Bit							
	7	6	5	4	3	2	1	0
0	Req = 001			0	0	0	0	
1	0	0	0	0	Channel			
2	0	0	0	0	0	0	0	0

Note: Bits labelled 0 should not be altered

#### Byte 0

**Debug Data:** 1 bit, specifying the debug data that should be returned. Either of two 16-bit debug data states may be requested:

**Debug Data = 0:** Reference – the reference level used by the QT2100 for comparison with the current measurements to detect touch. The reference value is a 16-bit unsigned integer.

**Debug Data = 1:** Delta – the difference between the reference level and the current level, indicating how close the channel is to detecting touch. The delta value is a 16-bit signed integer.

**Req:** Set to 001 to indicate Send Debug Data command mode.

#### Byte 1

**Channel:** 4 bits indicating the measurement channel for which the Send Debug Data is requested. Channels are mapped to keys or slider/wheel electrodes, as in [Table 5-10](#).

**Table 5-10. Channel Mappings**

Channel	Sensing Object
0	Key B1
1	Key B2
2	Key B3
3	Key B4
4	Key B5
5	Key B6
6	Key B7

**Table 5-10. Channel Mappings (Continued)**

Channel	Sensing Object
7	Slider/Wheel A1
8	Slider/Wheel A2
9	Slider/Wheel A3

**Byte 2**

Always set to 0.

**5.4.3 QT2100 Data**

During this exchange, the QT2100 returns the data requested on the previous exchange (Normal Data by default), and at the next exchange the requested debug data is returned.

**Table 5-11. Send Debug Data Command Mode – Return Bytes**

QT2100 Byte	Bit							
	7	6	5	4	3	2	1	0
0	State of Channel							
1	LSB Delta/LSB Reference							
2	MSB Delta/MSB Reference							

**Byte 0**

**State of Channel:** Indicates the current state of the channel.

**Table 5-12. Sensor States**

State Code	Sensor State
0x01	Calibration
0x02	No Detect (no touch)
0x04	Filter In (to confirm touch)
0x08	Detect (touched)
0x10	Filter out (to confirm release)
0x20	Recal (positive error recalibration)
0x40	Fault Check

**Byte 1**

**LSB Delta/LSB Reference:** The least significant 8 bits (LSB) of the Reference/Delta signal.

**Byte 2**

**MSB Delta/MSB Reference:** The most significant 8 bits (MSB) of the Reference/Delta signal.

## 5.5 Device Version

### 5.5.1 Introduction

In a **Device Version** exchange (Req = 010) the host requests the QT2100 to send the device ID and Firmware version information.

### 5.5.2 Host Data

In Device Version command mode the host sends the 3-byte data in [Table 5-13](#).

**Table 5-13. Device Version Command Mode – Host Command Bytes**

Host Byte	Bit							
	7	6	5	4	3	2	1	0
0	Req = 010			0	0	0	0	0
1	0	0	0	0	0	0	0	0
2	0	0	0	0	0	0	0	0

Note: Bits labelled 0 should not be altered

#### Byte 0

**Req:** Set to 010 to indicate Device Version command mode.

#### Byte 1

Always set to 0.

#### Byte 2

Always set to 0.

### 5.5.3 QT2100 Data

During this exchange, the QT2100 returns the data requested on the previous exchange (Normal Data by default), and at the next exchange the requested data is returned.

**Table 5-14. Device Version Command Mode – Return Bytes**

QT2100 Byte	Bit							
	7	6	5	4	3	2	1	0
0	Device ID = 108 (0x6C)							
1	Version Major				Version Minor			
2	Build							

#### Byte 0

**Device ID:** the device ID; always 108 (0x6C)

#### Byte 1

**Version Major:** 4 bits, indicating the major version of the device.

**Version Minor:** 4 bits, indicating the minor version of the device.

For example, firmware version 1.0 would be indicated as 0x10.

## Byte 2

**Build:** The build of this firmware version.

## 6. Specifications

### 6.1 Absolute Maximum Specifications

V <sub>DD</sub>	−0.3 to +6.0 V
Max continuous pin current, any control or drive pin	±20 mA
Short circuit duration to ground or V <sub>DD</sub> , any pin	Infinite
Voltage forced onto any pin	−0.3 V to (V <sub>DD</sub> + 0.3) V



**CAUTION:** Stresses beyond those listed under *Absolute Maximum Specifications* may cause permanent damage to the device. This is a stress rating only and functional operation of the device at these or other conditions beyond those indicated in the operational sections of this specification is not implied. Exposure to absolute maximum specification conditions for extended periods may affect device reliability

### 6.2 Recommended Operating Conditions

Operating temperature	−40°C to +85°C
Storage temperature	−50°C to +125°C
V <sub>DD</sub>	+2.0 to 5.5 V
Short-term supply ripple + noise	±20 mV / s
Long-term supply stability	±100 mV
C <sub>s</sub> range, keys	1 to 100 nF
C <sub>s</sub> range, slider/wheel	4.7 to 220 nF
C <sub>x</sub> range	0 to 50 pF

## 6.3 AC Specifications

Vdd = 5.0V, Cs keys = 4.7 nF, Cs slider/wheel = 15 nF; circuit of [Figure 1-1](#)

Parameter	Description	Min	Typ	Max	Units	Notes
Tsu	Start-up to SPI time	–	50	60	ms	From cold start $\geq$
Trc	Recalibration time	–	300	–	ms	Depends on ground loading of electrodes and Cs selection
Fc	Burst center frequency	–	100 80	–	kHz	Spread spectrum disabled Spread spectrum enabled
Fm	Burst modulation, percent	–	15	–	%	Total deviation
Tpc	Sample pulse duration	–	2.66 5.85	–	$\mu$ s	Spread spectrum disabled Spread spectrum enabled
Tbd	Acquire burst duration	–	20 25	–	ms	Spread spectrum disabled Spread spectrum enabled (Total for all 3 acquire burst groups)
Tdf6	Response time – Free Run mode, DI 6 samples	–	120	–	ms	Spread spectrum disabled
Tdf2	Response time – Free Run mode, DI 2 samples	–	40	–	ms	Spread spectrum disabled
Tdl	Response time – LP mode	–	280	–	ms	LP Mode 2, DI = six counts
Tdr	Release time – all modes	–	40	–	ms	End of touch

## 6.4 DC Specifications

Vdd = 5.0V, Cs keys = 4.7 nF, Cs slider/wheel = 15 nF; circuit of [Figure 1-1](#)

Parameter	Description	Min	Typ	Max	Units	Notes
Vil	Low input logic level	0	–	$0.3 \times V_{dd}$	V	
Vhl	High input logic level	$0.7 \times V_{dd}$	–	Vdd	V	
Vol	Low output voltage	–	–	0.5	V	7 mA sink
Voh	High output voltage	$V_{dd} - 0.5$	–	–	bits	2.5 mA source
Iil	Input leakage current	–	–	$\pm 1$	$\mu$ A	
Ar	Acquisition resolution	–	14	–	bits	
Trst	External reset low pulse width	2	–	–	$\mu$ s	

## 6.5 SPI Bus Specifications

Parameter	Specification
Data bits	8 data bits
Data transmission	Shift out on falling edge Shift in on rising edge Three bytes per transmission, byte 1 most significant bit sent first
Clock idle	Clock idle high
Maximum clock rate	750 kHz
Minimum time between exchanges	500 $\mu$ s

Figure 6-1. Data Byte Exchange – Signals

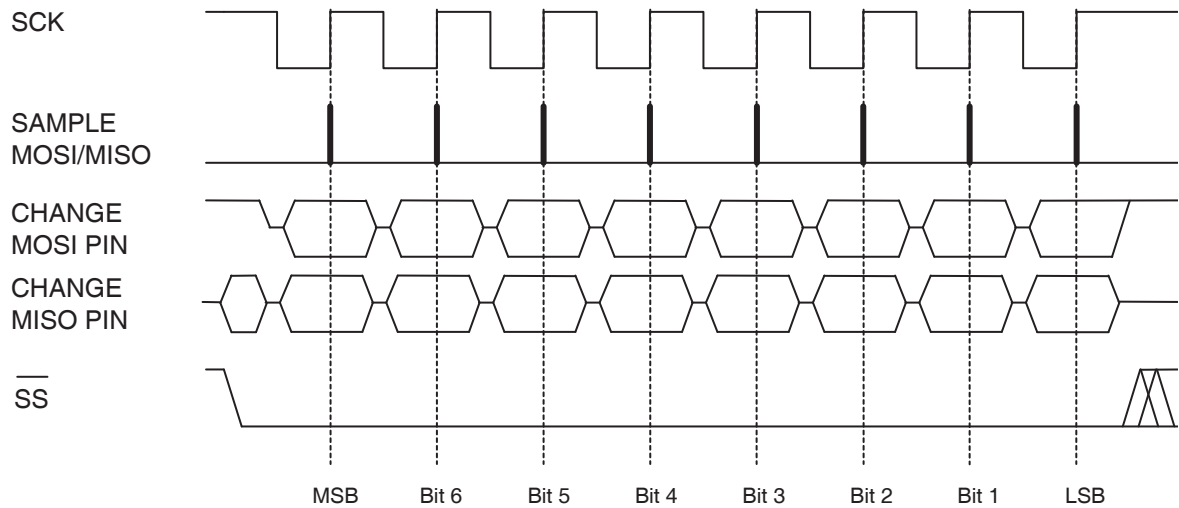
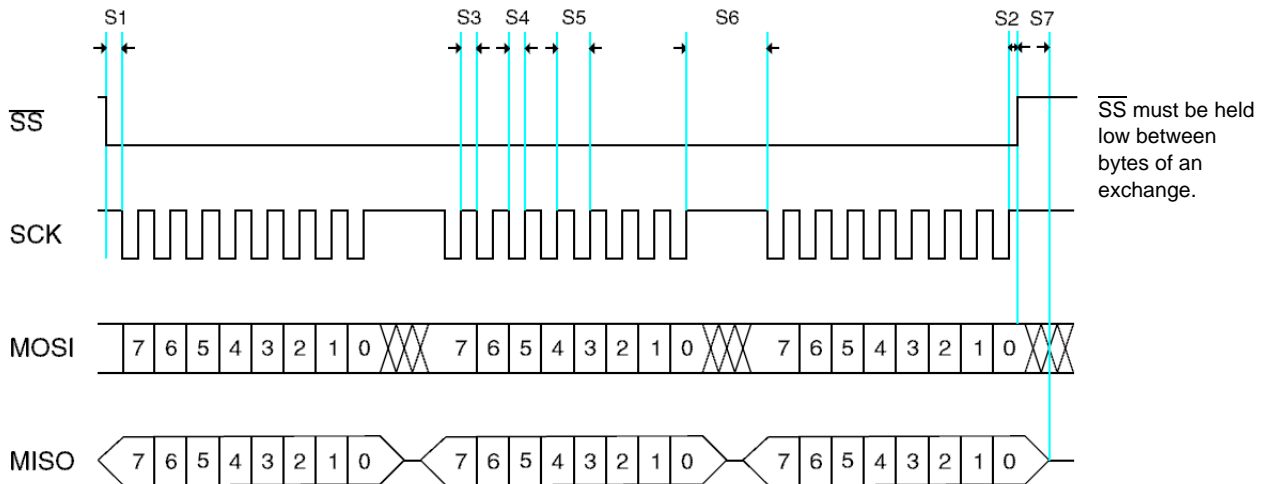




Figure 6-2. Data Byte Exchange – Timings



	Period	Min	Max	Unit
	$\overline{SS}$ Low to SCK – Free-run mode	2	–	$\mu\text{s}$
	$\overline{SS}$ Low to SCK – LP mode	22	–	$\mu\text{s}$
S2	SCK to $\overline{SS}$ High	20	–	$\mu\text{s}$
S3	SCK Low Pulse	666	–	ns
S4	SCK High Pulse	666	–	ns
S5	SCK Period	S1	–	ns
S6	Between Bytes		–	$\mu\text{s}$
S7	$\overline{SS}$ High to Tristate	–	20	ns

General	Min	Max	Unit
Rise/Fall Time	–	1600	ns
Setup	10	–	ns
Hold	333	–	ns

## 6.6 External Reset

Parameter	Description	Operation
$V_{RST}$	Threshold voltage low (Activate) Threshold voltage high (Release)	$0.2 \times V_{DD}$ $0.9 \times V_{DD}$

## 6.7 Internal Resonator

Parameter	Operation
Internal RC oscillator	8 MHz with spread-spectrum modifier during measurement bursts, if enabled

## 6.8 Signal Processing

Vdd = 5.0V, Cs keys = 4.7 nF, Cs slider/wheel = 15 nF; circuit of [Figure 1-1](#)

Description	Min	Units	Notes
Detection threshold (keys)	10	counts	Threshold for increase in Cx load
Detection threshold (slider/wheel)	30	counts	Changeable through SPI
Detection hysteresis (keys)	2	counts	
Detection hysteresis (slider/wheel)	5	counts	25 percent of slider/wheel detection threshold
DI filter, start of touch, normal mode	6	samples	Must be consecutive or detection fails
DI filter, start of touch, fast DI mode	2	samples	Must be consecutive or detection fails

## 6.9 Power Consumption

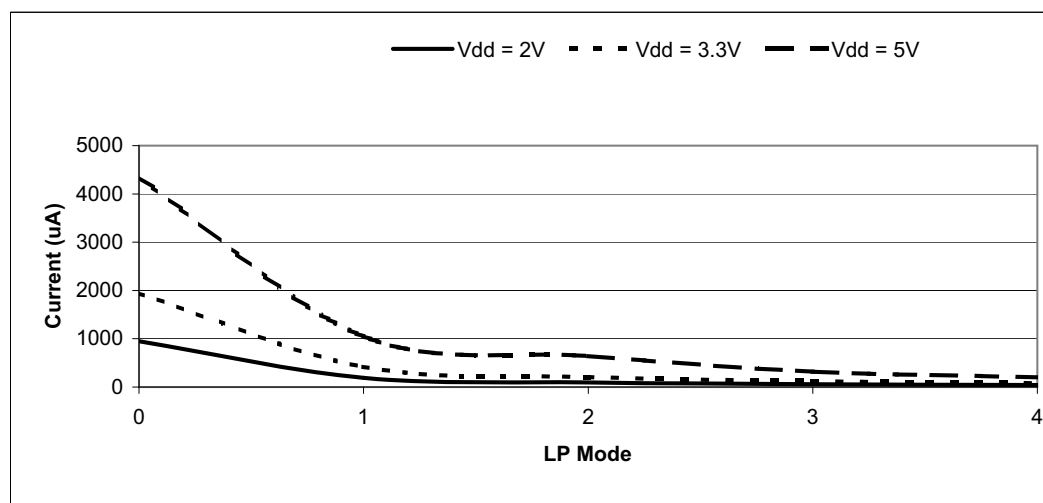
### 6.9.1 Spread Spectrum Disabled

Table 6-1. Power Consumption ( $\mu\text{A}$ )

LP Mode	Vdd		
	2 V	3.3 V	5 V
0	950	1940	4350
1	190	420	1050
2	95	205	640
3	60	120	320
4	40	80	200
Sleep	15	18	22

Note: Power measurements taken 4.7 nF capacitors on the keys and 15 nF capacitors on the slider electrodes.

Figure 6-3. Idd Curve



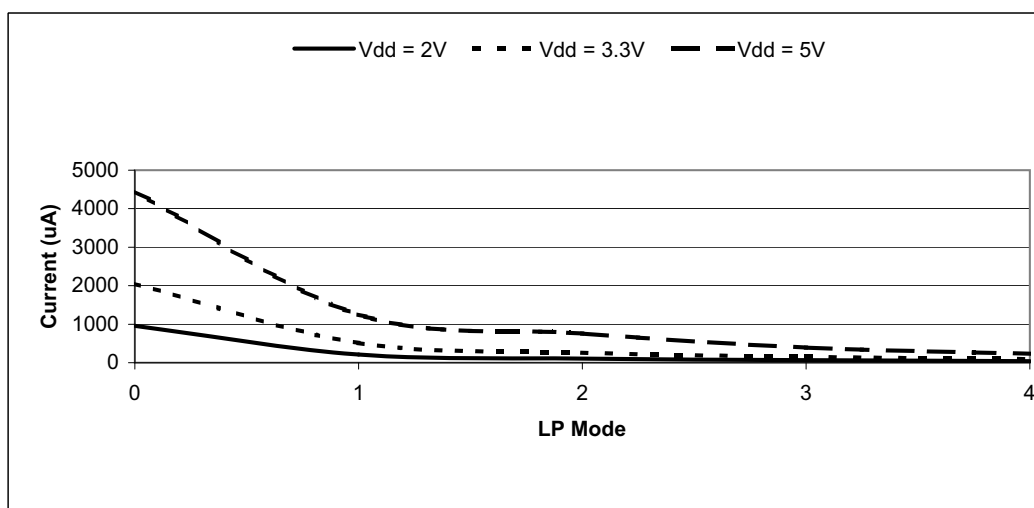
## 6.9.2 Spread Spectrum Enabled

Table 6-2. Power Consumption ( $\mu\text{A}$ )

LP Mode	Vdd		
	2 V	3.3 V	5 V
0	955	2050	4450
1	210	510	1250
2	105	260	760
3	65	150	390
4	40	95	235
Sleep	10	18	22

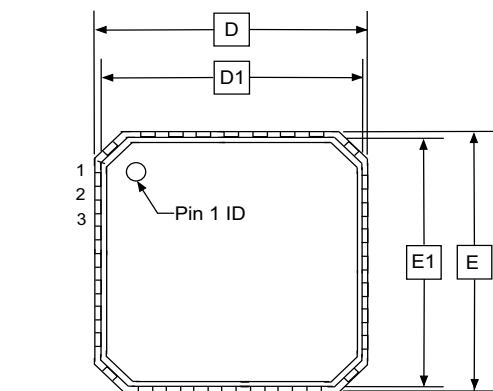
Note: Power measurements taken 4.7 nF capacitors on the keys and 15 nF capacitors on the slider electrodes.

Figure 6-4. I<sub>dd</sub> Curve

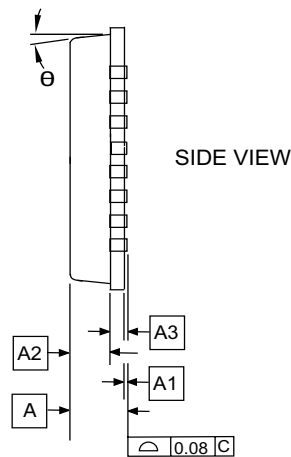


## 6.10 Mechanical Dimensions

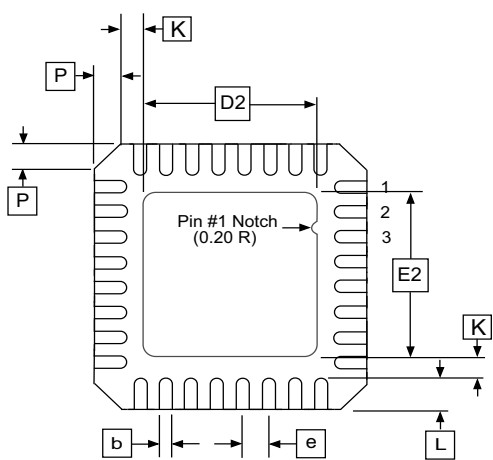
### 6.10.1 32-pin 5 x 5 mm MLF



TOP VIEW



SIDE VIEW



BOTTOM VIEW

COMMON DIMENSIONS  
(Unit of Measure = mm)

SYMBOL	MIN	NOM	MAX	NOTE
A	0.80	0.85	1.00	
A1	0.00	0.01	0.05	
A2	–	0.65	0.70	
A3	0.20 REF			
b	0.18	0.23	0.30	
D	4.90	5.00	5.10	
D1	4.70	4.75	4.80	
D2	2.95	3.10	3.25	
E	4.90	5.00	5.10	
E1	4.70	4.75	4.80	
E2	2.95	3.10	3.25	
e	0.50 BSC			
L	0.30	0.40	0.50	
P	–	–	0.60	
θ	–	–	12°	
K	0.20	–	–	

NOTES:

JEDEC Standard MO-220, Fig 2 (Anvil Singulation), VHHD-2.

1/10/13



Package Drawing Contact:  
packagedrawings@atmel.com

TITLE

**32M1-A**, 32-pad, 5x5x1.0 mm Body, Lead Pitch  
0.50mm, 3.10mm<sup>2</sup> Exposed Pad, Very-Thin,  
Fine Pitch Quad Flat No Lead Package (VQFN)

GPC

ZVY

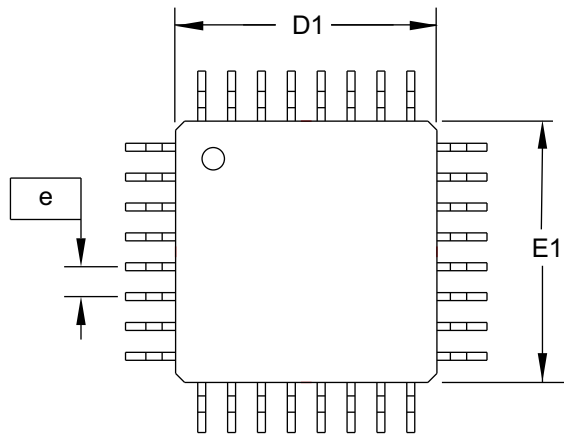
DRAWING NO.

32M1-A

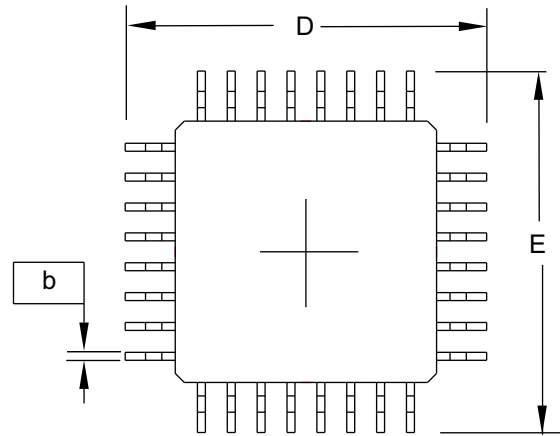
REV.

G

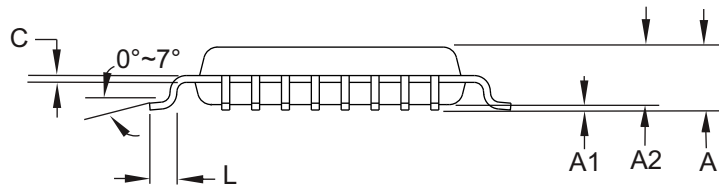
### 6.10.2 32-pin 7 x 7 mm TQFP



TOP VIEW



BOTTOM VIEW




SIDE VIEW

COMMON DIMENSIONS  
(Unit of Measure = mm)

SYMBOL	MIN	NOM	MAX	NOTE
A	–	–	1.20	
A1	0.05	–	0.15	
A2	0.95	1.00	1.05	
D	8.75	9.00	9.25	
D1	6.90	7.00	7.10	Note 2
E	8.75	9.00	9.25	
E1	6.90	7.00	7.10	Note 2
b	0.30	–	0.45	
C	0.09	–	0.20	
L	0.45	–	0.75	
e	0.80 TYP			

- Notes:
1. This package conforms to JEDEC reference MS-026, Variation ABA.
  2. Dimensions D1 and E1 do not include mold protrusion. Allowable protrusion is 0.25 mm per side. Dimensions D1 and E1 are maximum plastic body size dimensions including mold mismatch.
  3. Lead coplanarity is 0.10 mm maximum.

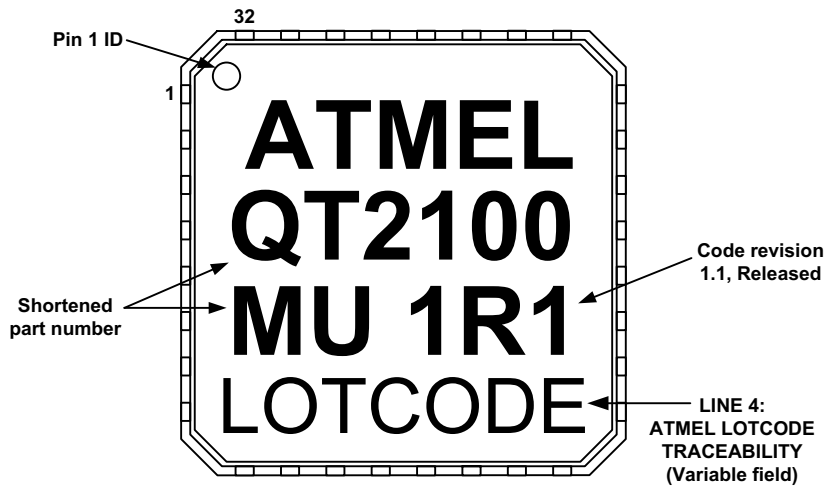
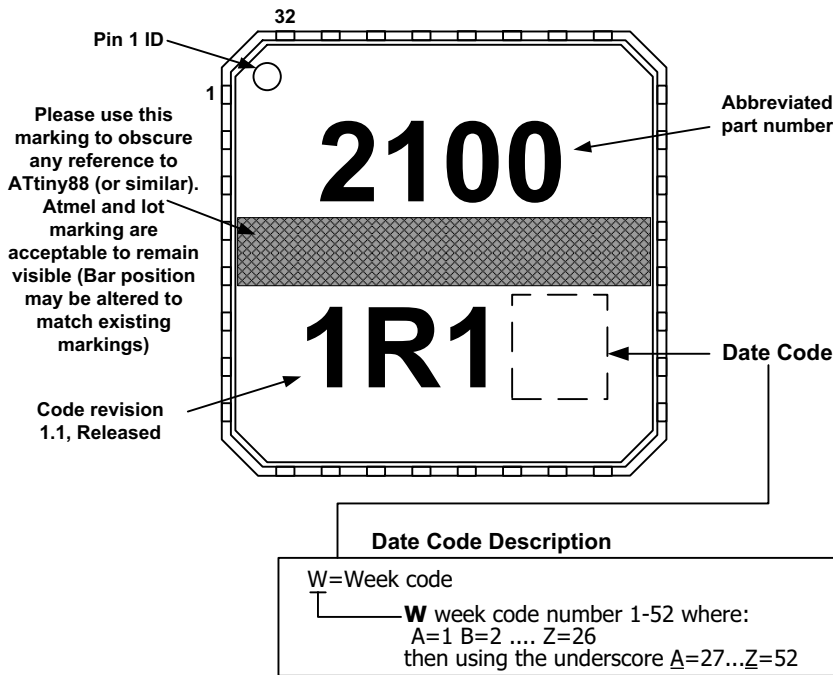
1/10/13

 Package Drawing Contact: packagedrawings@atmel.com	<b>TITLE</b> 32A, 32-lead 7.0 x 7.0x1.0 mm Body, 0.80 mm Lead Pitch, Thin Profile Plastic Quad Flat Package (TQFP)	<b>GPC</b> AUT	<b>DRAWING NO.</b> 32A	<b>REV.</b> D
--	---	-------------------	---------------------------	------------------

## 6.11 Part Marking

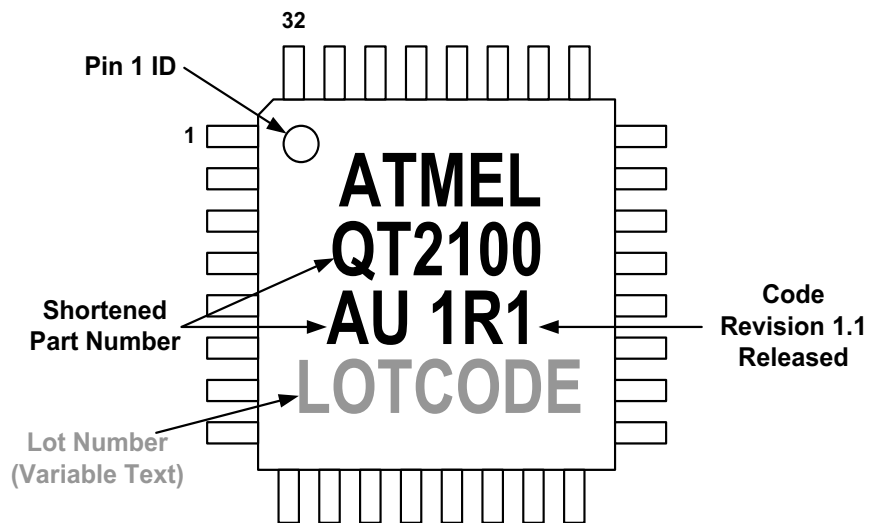
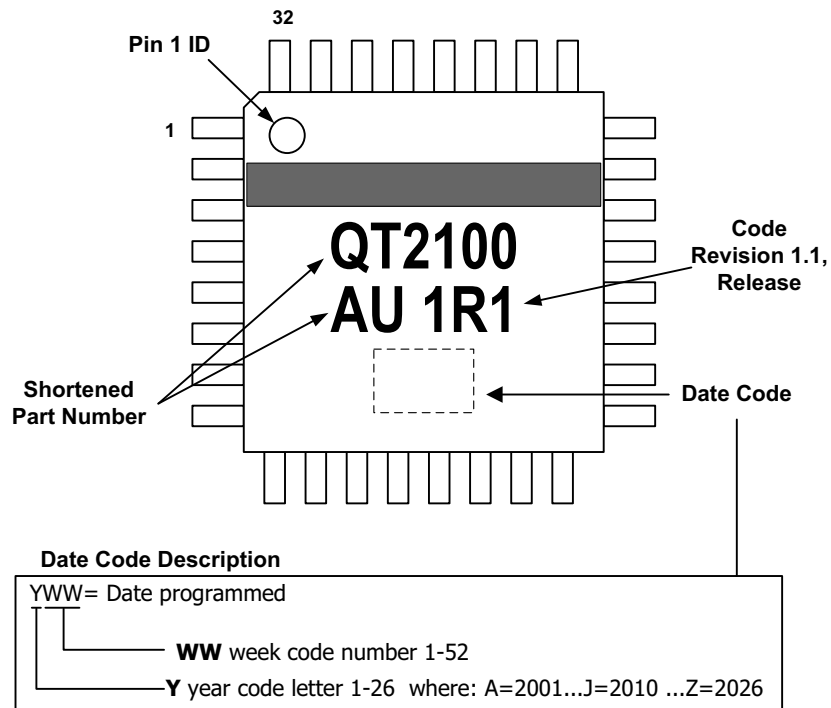
### 6.11.1 32-pin 5 x 5 mm MLF

Either part marking may be used. They are functionally identical.



### 6.11.2 32-pin 7 x 7 mm TQFP

Either part marking may be used. They are functionally identical



## 6.12 Part Numbers

Part Number	Description
AT42QT2100-MU	32-pin 5 × 5 mm MLF RoHS compliant IC
AT42QT2100-MUR	32-pin 5 × 5 mm MLF RoHS compliant IC
AT42QT2100-AU	32-pin 7 × 7 mm TQFP RoHS compliant IC
AT42QT2100-AUR	32-pin 7 × 7 mm TQFP RoHS compliant IC

The part number comprises:

AT = Atmel

42 = Touch Business Unit

QT = Charge-transfer technology

2100= (2) Slider/Wheel (10) number of channels (0) variant number

AU = TQFP chip

MU = MLF chip

R = Tape and reel

## 6.13 Moisture Sensitivity Level (MSL)

MSL Rating	Peak Body Temperature	Specifications
MSL3	260°C	IPC/JEDEC J-STD-020



## Appendix A. Migrating From QT1106 to QT2100

### A.1 Introduction

The QT2100 is a replacement for the QT1106. As such, it is host-compatible with the QT1106 allowing existing applications to be switched over without any changes to the host firmware.

Some changes to the application circuit will, however, be required and these are documented in this appendix.

### A.2 Pin Configuration

The QT2100 has a different pin-out to the QT1106 (see [Table A-1](#)).

**Table A-1.** Pin Compatibility

Pin	QT2100 Name	QT1106 Compatibility
1	SNSKB	SNSB
2	SNSB3	
3	SNSKB	SNSB
4	VDD	QT1106 range is +2.8 V to +5.0 V
5	VSS	
6	SNSKB	SNSB
7	SNSB4	
8	SNSB5	
9	SNSKB	SNSB
10	SNSKB	SNSB
11	SNSKB	SNSB
12	SNSB6	
13	SNSB7	
14	$\overline{SS}$	
15	MOSI	
16	MISO	
17	SCK	
18	VDD	QT1106 range is +2.8 V to +5.0 V
19	DRDY	Optional use on QT2100
20	CHANGE	
21	VSS	
22	SPREAD	External oscillator circuit not required for QT2100
23	SNSA1	
24	SNSKA	SNSA
25	SNSA2	

**Table A-1.** Pin Compatibility (Continued)

Pin	QT2100 Name	QT1106 Compatibility
26	SNSKA	SNSA
27	SNSA3	
28	SNSKA	SNSA
29	$\overline{\text{RESET}}$	
30	SNSB1	
31	SNSKB	SNSB
32	SNSB2	

### A.3 Spread Spectrum Implementation

A SPREAD pin is provided which may be tied to Vdd or Ground via a resistor to enable/disable spread-spectrum operation.

### A.4 Component Retuning

In general it is expected that unchanged sense components will show little difference with the QT2100 for the same sensor electrodes as the QT1106, but there may be cases where performance is improved by retuning component values of Cs and Rs to the application circuit.

### A.5 Components

An external oscillator is not required for QT2100.

### A.6 Proximity

On the QT2100 any of the keys can be configured as proximity sensors but see [Section 4.3.6 on page 15](#) for the exception to this.

## Associated Documents

---

For additional information, refer to the following document (downloadable from the Touch Technology area of the Atmel website, [www.atmel.com](http://www.atmel.com)):

- QTAN0079 Buttons, Sliders and Wheels Sensor Design Guide
- Atmel AVR3000: QTouch Conducted Immunity Application Note
- QTAN0087 Proximity Design Guide

## Revision History

---

Revision No.	History
Revision AX – March 2011	Initial release for chip revision 0.6 – Preliminary
Revision BX – March 2011	Updated for chip revision 1.0
Revision CX – November 2011	Updated for chip revision 1.1 – Released
Revision D – November 2012	General update
Revision E – January 2013	Applied new template



Enabling Unlimited Possibilities®

**Atmel Corporation**

1600 Technology Drive  
San Jose, CA 95110  
USA

**Tel:** (+1) (408) 441-0311

**Fax:** (+1) (408) 487-2600

[www.atmel.com](http://www.atmel.com)

**Atmel Asia Limited**

Unit 01-5 & 16, 19F  
BEA Tower, Millennium City 5

418 Kwun Tong Roa

Kwun Tong, Kowloon

HONG KONG

**Tel:** (+852) 2245-6100

**Fax:** (+852) 2722-1369

**Atmel München GmbH**

Business Campus

Parking 4

D-85748 Garching bei München

GERMANY

**Tel:** (+49) 89-31970-0

**Fax:** (+49) 89-3194621

**Atmel Japan G.K.**

16F Shin-Osaki Kangyo Bldg

1-6-4 Osaki, Shinagawa-ku

Tokyo 141-0032

JAPAN

**Tel:** (+81) (3) 6417-0300

**Fax:** (+81) (3) 6417-0370

© 2011 – 2013 Atmel Corporation. All rights reserved. / Rev.: 9554E--AT42--01/13

Atmel®, Atmel logo and combinations thereof, Adjacent Key Suppression®, AKS®, QTouch® and others are registered trademarks, QT™ and others are trademarks of Atmel Corporation or its subsidiaries. Other terms and product names may be registered trademarks or trademarks of others.

Disclaimer: The information in this document is provided in connection with Atmel products. No license, express or implied, by estoppel or otherwise, to any intellectual property right is granted by this document or in connection with the sale of Atmel products. EXCEPT AS SET FORTH IN THE ATMEL TERMS AND CONDITIONS OF SALES LOCATED ON THE ATMEL WEBSITE, ATMEL ASSUMES NO LIABILITY WHATSOEVER AND DISCLAIMS ANY EXPRESS, IMPLIED OR STATUTORY WARRANTY RELATING TO ITS PRODUCTS INCLUDING, BUT NOT LIMITED TO, THE IMPLIED WARRANTY OF MERCHANTABILITY, FITNESS FOR A PARTICULAR PURPOSE, OR NON-INFRINGEMENT. IN NO EVENT SHALL ATMEL BE LIABLE FOR ANY DIRECT, INDIRECT, CONSEQUENTIAL, PUNITIVE, SPECIAL OR INCIDENTAL DAMAGES (INCLUDING, WITHOUT LIMITATION, DAMAGES FOR LOSS AND PROFITS, BUSINESS INTERRUPTION, OR LOSS OF INFORMATION) ARISING OUT OF THE USE OR INABILITY TO USE THIS DOCUMENT, EVEN IF ATMEL HAS BEEN ADVISED OF THE POSSIBILITY OF SUCH DAMAGES. Atmel makes no representations or warranties with respect to the accuracy or completeness of the contents of this document and reserves the right to make changes to specifications and products descriptions at any time without notice. Atmel does not make any commitment to update the information contained herein. Unless specifically provided otherwise, Atmel products are not suitable for, and shall not be used in, automotive applications. Atmel products are not intended, authorized, or warranted for use as components in applications intended to support or sustain life.

# Mouser Electronics

Authorized Distributor

Click to View Pricing, Inventory, Delivery & Lifecycle Information:

[Microchip:](#)

[AT42QT2100-MUR](#)

Компания «Life Electronics» занимается поставками электронных компонентов импортного и отечественного производства от производителей и со складов крупных дистрибьюторов Европы, Америки и Азии.

С конца 2013 года компания активно расширяет линейку поставок компонентов по направлению коаксиальный кабель, кварцевые генераторы и конденсаторы (керамические, пленочные, электролитические), за счёт заключения дистрибьюторских договоров

Мы предлагаем:

- Конкурентоспособные цены и скидки постоянным клиентам.
- Специальные условия для постоянных клиентов.
- Подбор аналогов.
- Поставку компонентов в любых объемах, удовлетворяющих вашим потребностям.
- Приемлемые сроки поставки, возможна ускоренная поставка.
- Доставку товара в любую точку России и стран СНГ.
- Комплексную поставку.
- Работу по проектам и поставку образцов.
- Формирование склада под заказчика.
- Сертификаты соответствия на поставляемую продукцию (по желанию клиента).
- Тестирование поставляемой продукции.
- Поставку компонентов, требующих военную и космическую приемку.
- Входной контроль качества.
- Наличие сертификата ISO.

В составе нашей компании организован Конструкторский отдел, призванный помогать разработчикам, и инженерам.

Конструкторский отдел помогает осуществить:

- Регистрацию проекта у производителя компонентов.
- Техническую поддержку проекта.
- Защиту от снятия компонента с производства.
- Оценку стоимости проекта по компонентам.
- Изготовление тестовой платы монтаж и пусконаладочные работы.



Тел: +7 (812) 336 43 04 (многоканальный)

Email: [org@lifeelectronics.ru](mailto:org@lifeelectronics.ru)