

BF SERIES



Split Ferrite Suppressors for Round Cables



Electronic cables and wires, by virtue of their length-to-width ratios, are perfect natural antennas. In the presence of high speed microprocessor signals, cables will conduct, radiate and/or receive unwanted high frequency interfering signals. Radio interference sources usually radiate their RFI power at frequencies above 30 MHz by way of the main cabling, which acts as an antenna. Control of radio interference can be assured by proper placement of an insertion loss device, such as a ferrite suppressor. Any device used to block an RFI signal between its source and a receiver is an electromagnetic interference (EMI) shield. The measure of this ability to attenuate RFI is shielding effectiveness, "SE", which is expressed in decibels, "dB", the ratio of field strength on one side of the shield to the other side.

One of the most versatile and cost effective shielding methods that can be used today is the API Delevan bisected ferrite cable snap assembly. The bisected styling, or familiar clamshell enclosure design offers the ultimate in adaptability. The RF absorbing material interacts directly with unwanted high frequency energy and dissipates it effectively while allowing data signals to pass unimpeded.

Bisected ferrites have a concentrated, homogeneous magnetic structure with high permeability. These are consistently stable at +20°C to +60°C and provide RF suppression without eddy current losses.

AIR GAP EFFECT

The air gap in bisected ferrites actually extends current carrying capabilities with only an extremely small reduction in impedance versus solid ferrites of the same size. The gap is magnetically insignificant while it is electrically significant as a discontinuity, thereby accommodating more current.

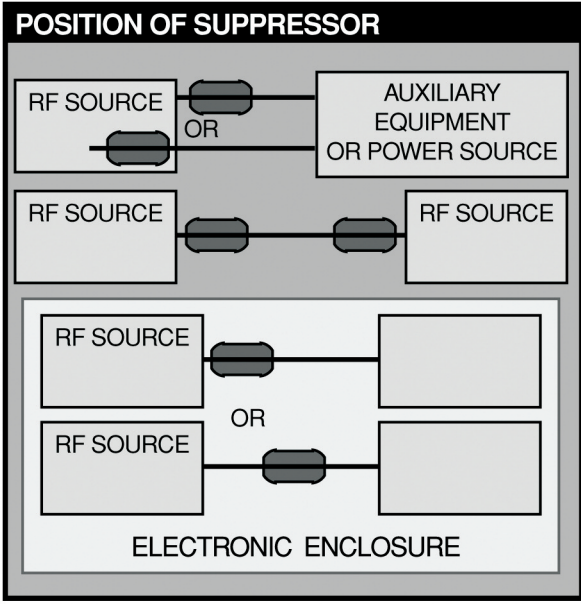

POSITION OF SUPPRESSOR The suppressor should normally be located close to the cable termination where it exits the enclosure. Where a cable connects two enclosures containing RF sources, a suppressor on each end may be required. For circuits within an enclosure, a position close to the RF is best. However, other locations along the circuit may work as well.

Material and U.L. Data API-1 Material, see characteristics and information in the Technical Notes Section of our website, www.delevan.com.

Continued on next page

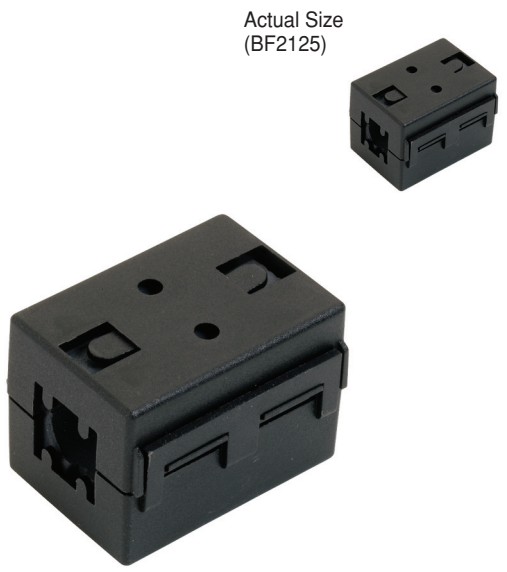

BF SERIES



Suppressors for Round Cables

DIMENSIONS
Inches ± 0.04; mm ± 1.0

IMPED-
ANCE
(OHMS)*

25 MHz

100 MHz

PART NUMBER

BODY TYPE
UNITS

A

B

C

D

L

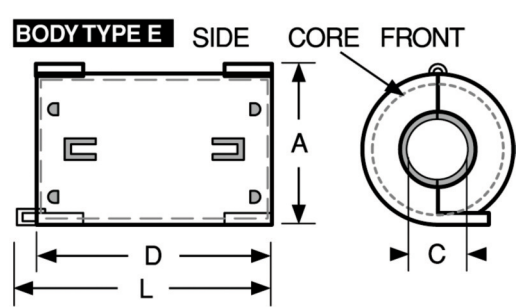
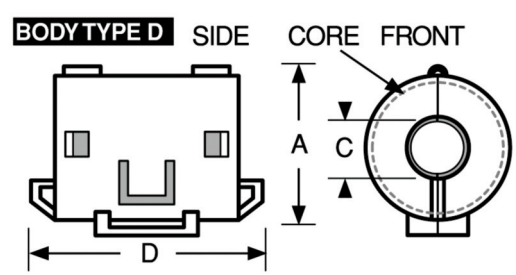
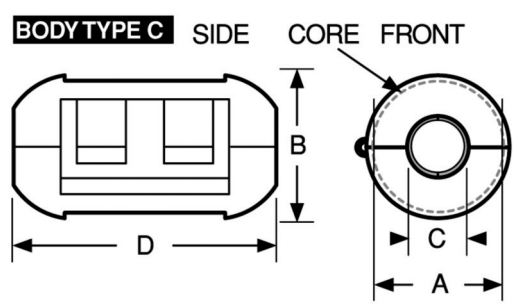
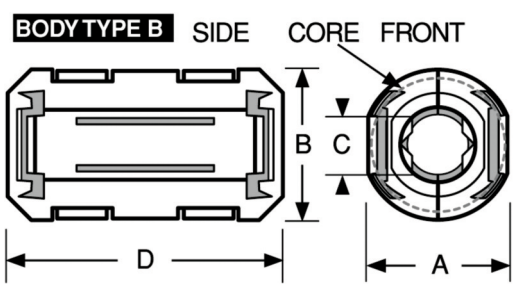
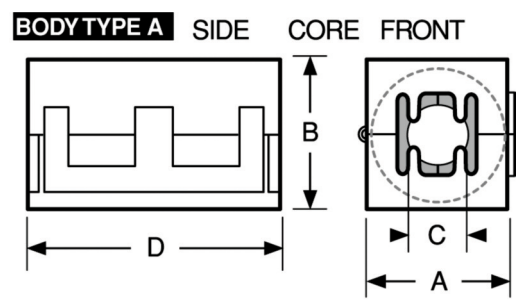

SERIES BF - FOR ROUND CABLES									
PART NUMBER	UNITS	BODY TYPE	A	B	C	D	L	25 MHz	100 MHz
BF2930	in. mm	A	1.16 29.6	1.20 30.5	0.51 13.0	1.30 33.0	—	155	257
BF2223	in. mm	A	0.87 22.3	0.91 23.3	0.39 10.0	1.28 32.6	—	136	250
BF1719	in. mm	A	0.70 17.8	0.76 19.5	0.25 6.5	1.28 32.5	—	171	325
BF1835	in. mm	B	0.70 18.0	0.77 19.7	0.35 9.0	1.37 35.0	—	112	172
BF1125-5	in. mm	B	0.46 11.7	0.51 13.0	0.19 5.0	0.98 25.0	—	96	154
BF1125-3	in. mm	B	0.46 11.7	0.51 13.0	0.13 3.5	0.98 25.0	—	139	191
BF1429	in. mm	C	0.57 14.5	0.61 15.7	0.22 5.6	1.14 29.0	—	85	157
BF1225	in. mm	C	0.50 12.8	0.57 14.7	0.15 4.0	0.98 25.0	—	82	146
BF3024	in. mm	D	1.20 30.5	—	0.45 11.4	0.69 17.7	0.94 24.0	51	103
BF2125	in. mm	D	0.84 21.5	—	0.32 8.15	0.77 19.7	1.01 25.8	50	107
BF2123	in. mm	D	0.84 21.5	—	0.32 8.15	0.66 16.8	0.90 23.0	42	94
BF1835-9	in. mm	E	0.73 18.6	—	0.35 9.0	1.22 31.0	1.38 35.2	126	174
BF3121	in. mm	D	1.24 31.5	—	0.59 15.0	0.60 15.2	0.84 21.5	41	95

Physical Parameters

Material and U.L. Data API-1 Material, see characteristics and information in the Technical Notes Section.

* **Note** Impedance is typical, based on 1/2 turn (4.0") 18 AWG wire. Impedance measurement using HP4191A.

Color Black; Special colors Available for bases on a non-cancellable, non returnable basis C = Cream; W = White; Gr = Grey

U.L. Recognized

All plastic and adhesive components use U.L. Recognized materials with Flammability Ratings of UL94V-0, UL-510 or UL-746C

SEE Z vs. f GRAPHS ON NEXT PAGE

BF SERIES



Split Ferrite Suppressors for Round Cables

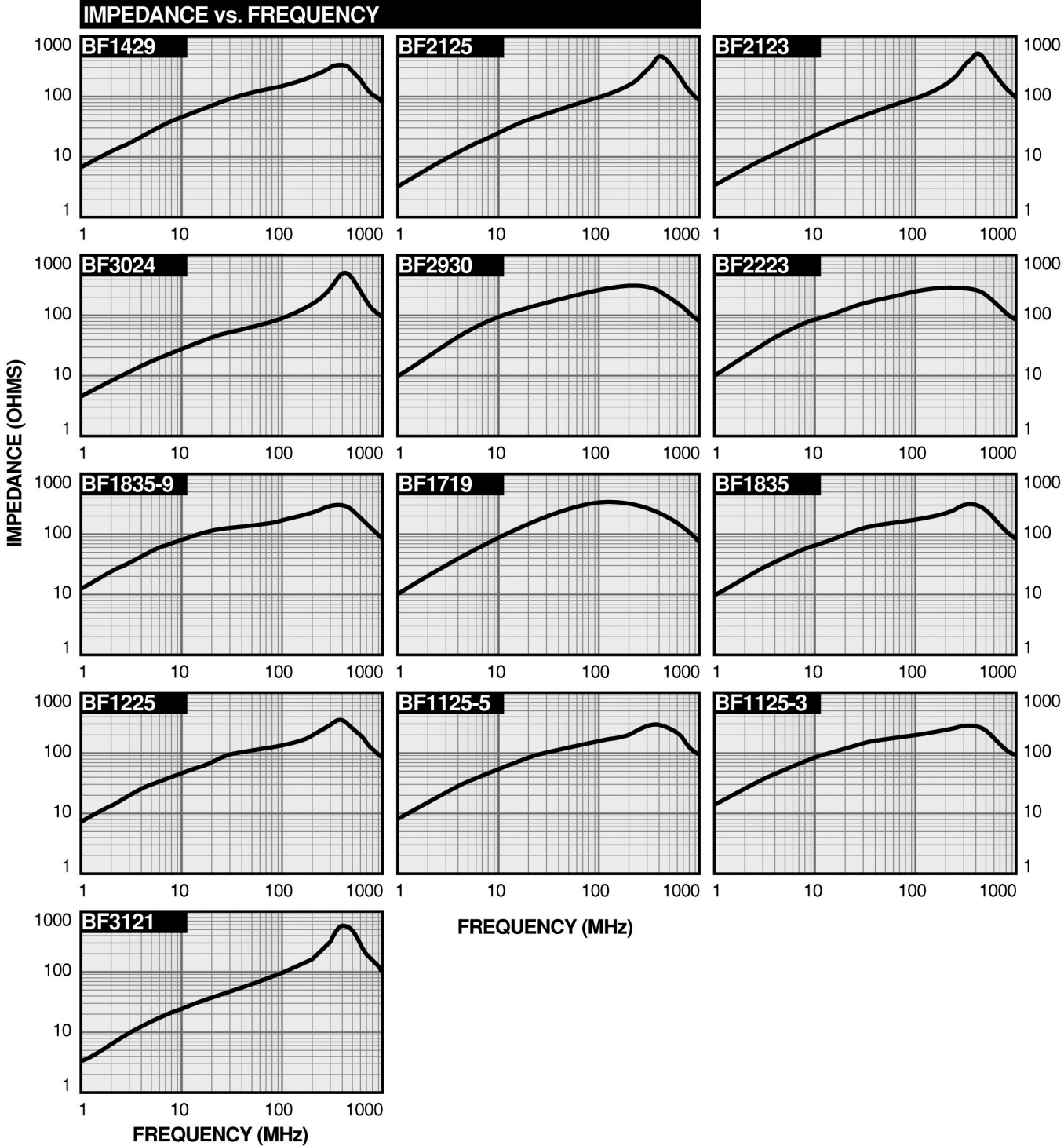

Additional Information on Preceding Pages

Note Impedance is typical, based on 1/2 turn (4.0") 18 AWG wire. Impedance measurement using HP4191A



Компания «Life Electronics» занимается поставками электронных компонентов импортного и отечественного производства от производителей и со складов крупных дистрибьюторов Европы, Америки и Азии.

С конца 2013 года компания активно расширяет линейку поставок компонентов по направлению коаксиальный кабель, кварцевые генераторы и конденсаторы (керамические, пленочные, электролитические), за счёт заключения дистрибьюторских договоров

Мы предлагаем:

- Конкурентоспособные цены и скидки постоянным клиентам.
- Специальные условия для постоянных клиентов.
- Подбор аналогов.
- Поставку компонентов в любых объемах, удовлетворяющих вашим потребностям.
- Приемлемые сроки поставки, возможна ускоренная поставка.
- Доставку товара в любую точку России и стран СНГ.
- Комплексную поставку.
- Работу по проектам и поставку образцов.
- Формирование склада под заказчика.
- Сертификаты соответствия на поставляемую продукцию (по желанию клиента).
- Тестирование поставляемой продукции.
- Поставку компонентов, требующих военную и космическую приемку.
- Входной контроль качества.
- Наличие сертификата ISO.

В составе нашей компании организован Конструкторский отдел, призванный помогать разработчикам, и инженерам.

Конструкторский отдел помогает осуществить:

- Регистрацию проекта у производителя компонентов.
- Техническую поддержку проекта.
- Защиту от снятия компонента с производства.
- Оценку стоимости проекта по компонентам.
- Изготовление тестовой платы монтаж и пусконаладочные работы.



Тел: +7 (812) 336 43 04 (многоканальный)
Email: org@lifeelectronics.ru