

NEW

Micro-USB connectors meeting requirements of USB 2.0 Standard

ZX Series

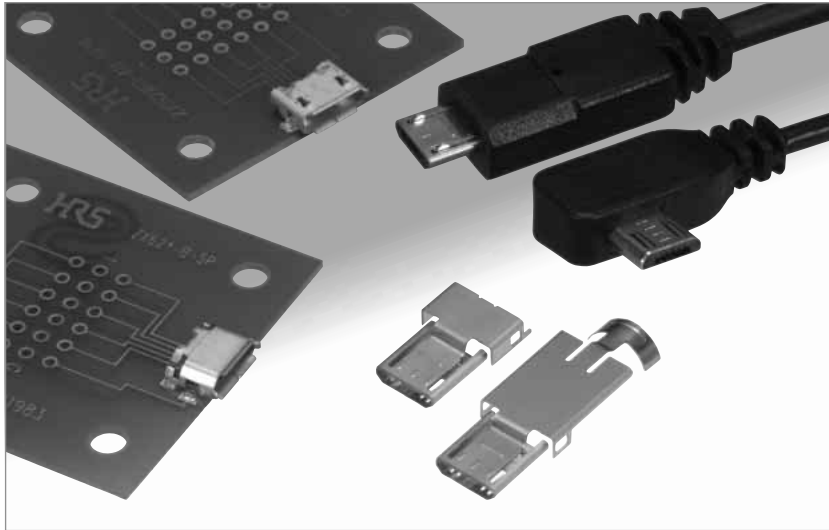

Note: Contact us to ascertain whether a TID number has been acquired for an individual product.

Overview

Extremely small high reliability connectors complying with physical, electrical and environmental requirements of Micro-USB standard (USB 2.0).

Receptacles and plugs are available in a wide variety of mounting and termination configurations, permitting their use in various applications.

Features

1. Size reduction

Compared with the standard Mini-B connectors, the size of ZX connectors is reduced by approximately 60% while still allowing a high-speed data transfer of 480 Mbps, specified in USB 2.0.

2. Receptacle styles

Two interface configurations: Micro-B and Micro-AB in standard, mid-mount and reverse mounting styles. SMT and through-hole (shell) PC board terminations

3. Plug styles

Corresponding to the receptacle styles, two interface configurations: Micro-B and Micro-A, with direct wire or PCB wire soldering. Several plug styles can be used for data transmission, earphone or charging applications.

4. High durability

Unique contact and lock configuration assures high durability while maintaining easy insertion / disconnection. Fully mated condition (when mated with corresponding HRS connector) is confirmed by a definite tactile sensation

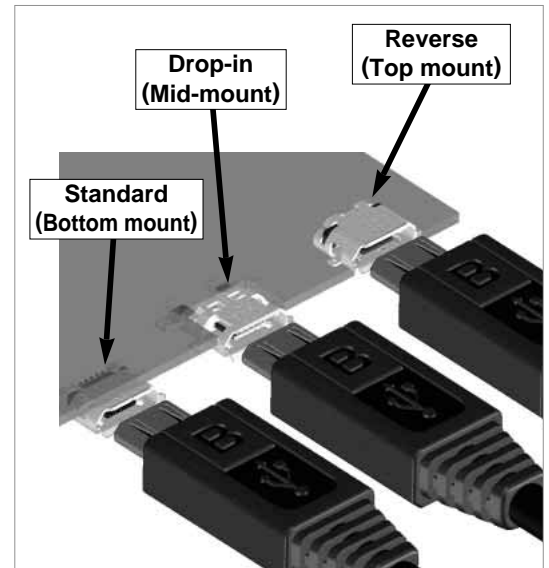

USB 2.0 Hi-Speed (480 Mbps)

Eye pattern measurement results:
Measured with USB 2.0 cable 2.4 m long

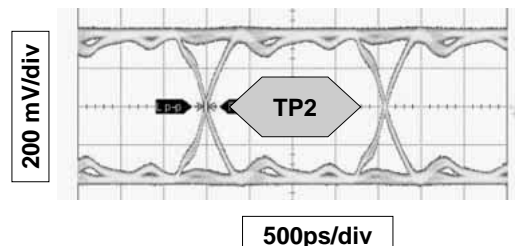

■ Specifications

| | | | | |
|---------|----------------|--|-----------------------------|-------------------------|
| Ratings | Current rating | 1 A (per contact) or 1.8 A (contacts No. 1 and 5) and 0.5 A (contacts No. 2, 3, and 4) | Voltage rating | 30 V AC |
| | | | Operating temperature range | -30°C to +85 °C (Note1) |
| | | | Storage temperature range | -30 °C to +85°C |

| Item | Specification | Conditions |
|----------------------------------|---|--|
| 1. Contact resistance | 30 mΩ max. | 100 mA |
| 2. Withstanding voltage | No flashover or insulation breakdown | 100 V AC / 1 minute |
| 3. Capacitance | 2 pF max. | Between adjacent contacts at 1,000 Hz (AC voltage) |
| 4. Durability | Contact resistance: Rise from initial value of 10 mΩ max. | 10,000 cycles |
| 5. Total insertion/removal force | Insertion force: 35 N max., Removal force: 8 N min. | Mated with corresponding connector |

Note1: Includes temperature rise caused by current flow.

Note2: Information contained in this catalog represents general requirements for this Series. Contact us for the drawings and specifications for a specific part number shown.

■ Materials

● Receptacles

| Part | Material | Finish | Remarks |
|-----------|-----------------|--------------------------------|---------|
| Insulator | LCP | Micro-B: Black, Micro-AB: Gray | UL94V-0 |
| Contacts | Copper alloy | Selective gold plated | _____ |
| Shell | Stainless steel | Tin alloy plating | _____ |

● Plugs

| Part | Material | Finish | Remarks |
|-------------|-----------------|--------------------------------|---------|
| Insulator | Synthetic resin | Micro-A: White, Micro-B: Black | UL94V-0 |
| Contacts | Copper alloy | Selective gold plated | _____ |
| Lock spring | Stainless steel | _____ | _____ |
| Shell | Stainless steel | Nickel plated or unfinished | _____ |

■ Ordering information

● Receptacles

ZX 62 RD - B - 5 P * 8
① ② ③ ④ ⑤ ⑥ ⑦ ⑧

● Plugs

ZX 40 - B - 5 S * - UNIT
① ② ④ ⑤ ⑥ ⑦ ⑨

ZX 40 - B - SLDA
① ② ④ ⑨

| | | |
|---|---|---|
| ① Series name | ZX | |
| ② Termination style | 10's: Right-angle PCB wire, SMT 20's: Straight, PCB wire 40's: Direct wire 60's: Right-angle, PCB wire 80's: Cradle SMT | |
| ③ Board mounting style (Receptacles) | Blank | Standard (Bottom mount) |
| | D | Standard (Bottom mount) through hole |
| | R | Reverse (Top mount) |
| | RD | Reverse (Top mount) through hole |
| | M | Drop-in (Mid-mount) |
| ④ Mating side configuration | A | Micro-A |
| | B | Micro-B |
| | AB | Micro-AB |
| ⑤ Number of contacts | 5 | |
| ⑥ Contact type | P | Receptacle- Male |
| | S | Plug - Female |
| ⑦ Serial No. | | |
| ⑧ Shell termination style - Receptacles | Blank | SMT |
| | 8 | Through hole (solder tab length: 0.8mm) |
| ⑨ Components-plugs | UNIT | Assembly (Insulator/contact/lock) |
| | SLD* | Cover (Note 1) |

Note 1: Classifiers such as A, B, and C are entered for *.

■ Product Styles Table

| Interface | Receptacle | Plug |
|-----------|------------|------|
| Micro-A | | |
| Micro-B | | |
| Micro-AB | | |

■ Configurations

| | Mating side configuration | Application | Mounting, termination styles/wire attachment | Part Number | 3D Image | Page | |
|---|---------------------------|-------------|--|---|--|-----------|-----------|
| R e c e p t a c l e s | Micro-B | Standard | SMT | ZX62-B-5PA(11) | | 4 | |
| | | | SMT + DIP | ZX62D-B-5PA8 | | 4 | |
| | | Reverse | SMT | ZX62R-B-5P | | 5 | |
| | | Drop-in | SMT | ZX62M-B-5P(02) | | 5 | |
| | Micro-AB | Standard | SMT | ZX62-AB-5PA(11) | | 6 | |
| | | | SMT + DIP | ZX62D-AB-5P8 | | 6 | |
| | | Reverse | SMT | ZX62R-AB-5P | | 7 | |
| | | | SMT + DIP | ZX62RD-AB-5P8 | | 7 | |
| | P l u g s | Micro-B | Data | Direct wire soldering | Assembly (insulator/contacts/lock) :ZX40-B-5S-UNIT(12) Cover-top :ZX40-B-SLDA Cover-bottom :ZX40-SLDB | | 9 and 10 |
| | | | | PCB wire soldering (right angle, through hole) | Assembly (insulator/contacts/lock) :ZX10-B-5S-UNIT(12) Cover-top :ZX10-B-SLDA Cover-bottom :ZX10-SLDB(3.3) | | 11 and 12 |
| Earphone | | | PCB wire soldering (straight, through hole) | Assembly (insulator/contacts/lock) :ZX20-B-5S-UNIT(12) Cover :ZX20-B-SLDC | | 13 | |
| Charging | | | PCB wire soldering (SMT) | Assembly (insulator/contacts/lock) :ZX64-B-5S-UNIT(14) Cover-top :ZX64-B-SLDA Cover-bottom :ZX64-SLDB | | 14 and 15 | |
| Charging Earphone | | | PCB wire soldering (SMT) | Assembly (insulator/contacts/lock) :ZX64-B-5S-UNIT(14) Cover :ZX64-B-SLDC | | 14 and 16 | |
| Micro-A | | Data | Direct wire soldering | Assembly (insulator/contacts/lock) :ZX40-A-5S-UNIT Cover-top :ZX40-A-SLDA Cover-bottom :ZX40-SLDB | | 17 and 18 | |
| C r a d l e s | Micro-B | Cradle | SMT + DIP | ZX80-B-5S | With lock | 19 | |
| | | | | ZX80-B-5SA | Without lock | 19 | |

Note: 1. Part numbers in the Plugs section of the above table list the Assembly (insulator/contacts/locks) and the corresponding Shields/Covers.
 Note: 2. Optional Printed Circuit boards for the Plugs are shown for reference only. Not supplied with applicable connectors.
 Note: 3. The color of the insulators body in the Assembly (insulator/contacts/lock) shown in the 3D Image column above is blue for clarity. Refer to the Materials (Page 2) for correct colors.

■ Receptacles

● Micro B - Standard (Bottom mount), Shell SMT

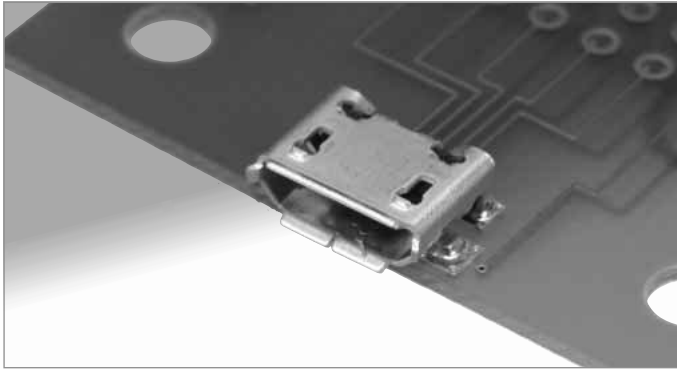

| Part Number | CL No. | Packaging |
|----------------|---------------|-----------------------|
| ZX62-B-5PA(11) | 242-0033-8-11 | 3,500 pieces per reel |

■ Recommended PCB mounting pattern

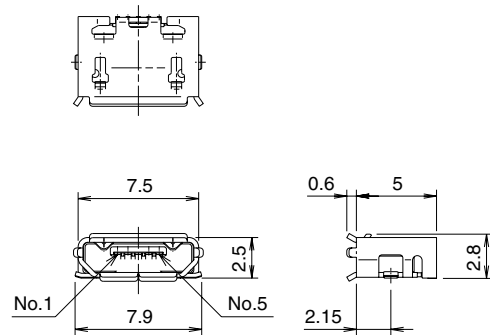
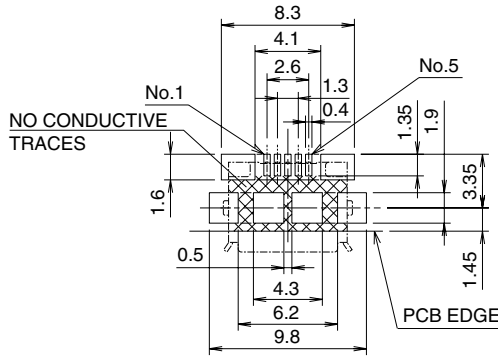

● Micro B - Standard (Bottom mount), Shell through hole

All dimensions: mm

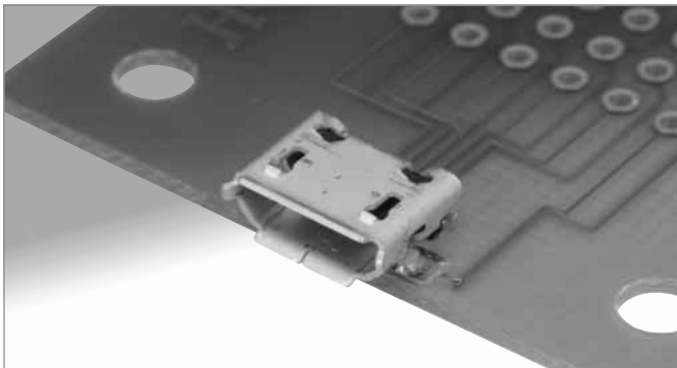

| Part Number | CL No. | Packaging |
|--------------|------------|-----------------------|
| ZX62D-B-5PA8 | 242-0056-3 | 2,000 pieces per reel |

■ Recommended PCB mounting pattern

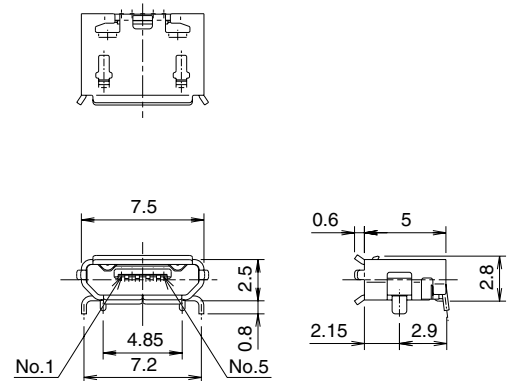
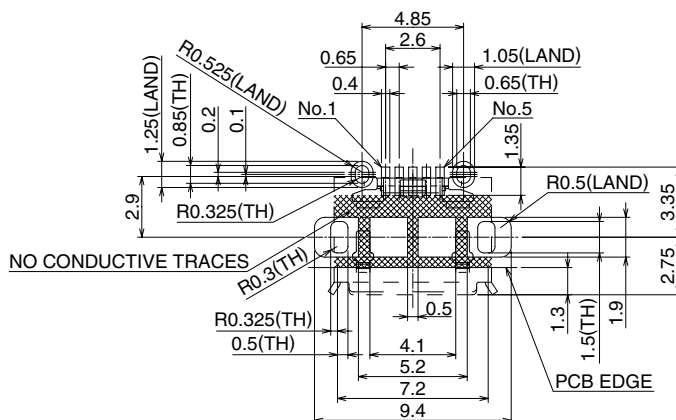

All dimensions: mm

■ Receptacles

● Micro B - Reverse (Top mount) Shell SMT

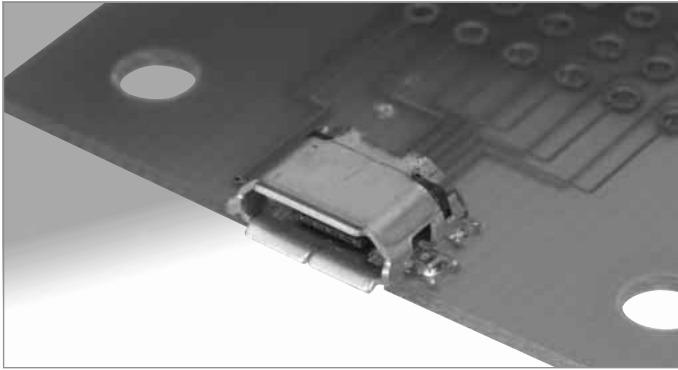

| Part Number | CL No. | Packaging |
|-------------|------------|-----------------------|
| ZX62R-B-5P | 242-0028-8 | 2,000 pieces per reel |

■ Recommended PCB mounting pattern

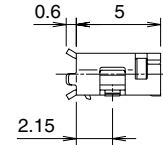
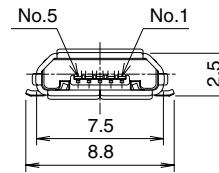
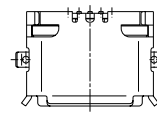
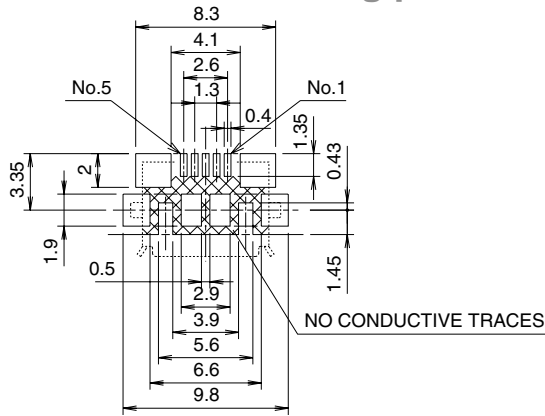

● Micro B - Drop-in (Mid-mount), Shell SMT

All dimensions: mm

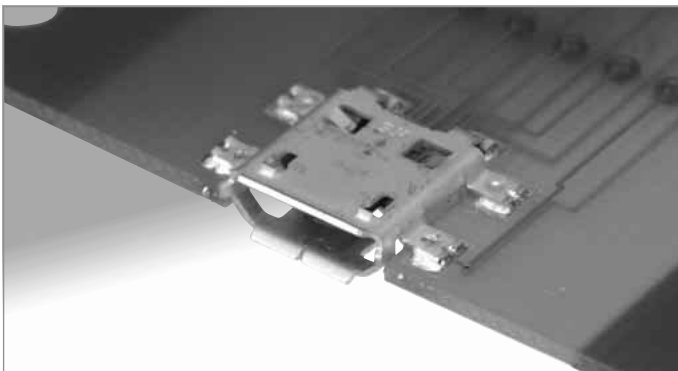

| Part Number | CL No. | Packaging |
|----------------|---------------|-----------------------|
| ZX62M-B-5P(02) | 242-0024-7-02 | 2,000 pieces per reel |

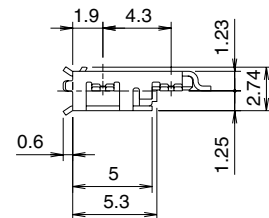
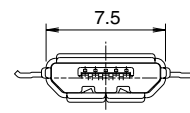
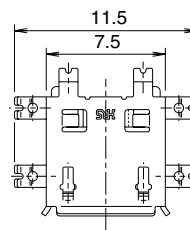

■ Recommended PCB mounting pattern

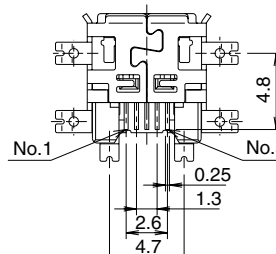
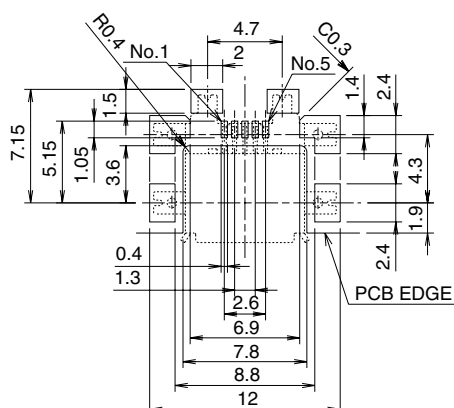

All dimensions: mm

Receptacles

Micro AB - Standard (Bottom mount), Shell SMT

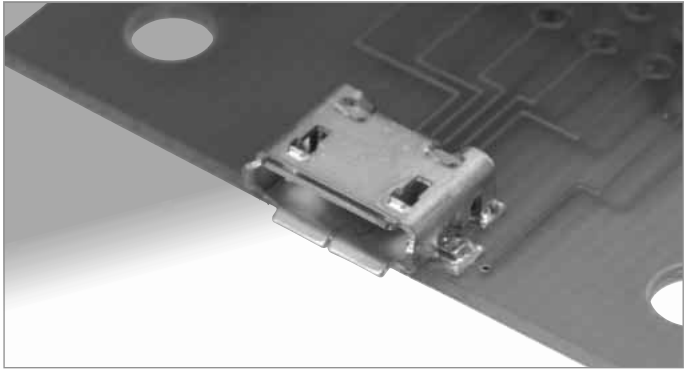

| Part Number | CL No. | Packaging |
|-----------------|---------------|-----------------------|
| ZX62-AB-5PA(11) | 242-0045-7-11 | 3,500 pieces per reel |

Recommended PCB mounting pattern

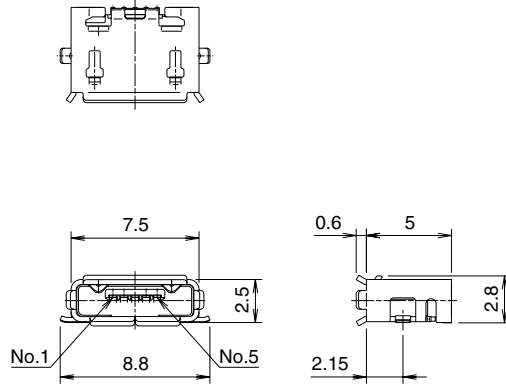
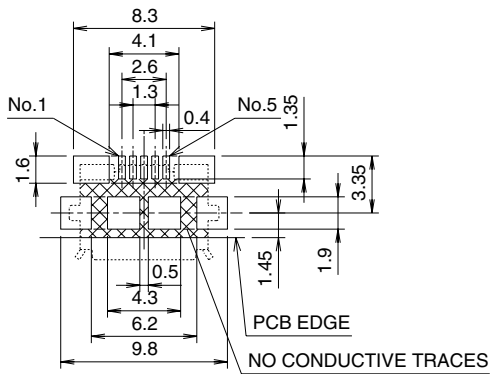

Micro AB - Standard (Bottom mount), Shell through hole

All dimensions: mm

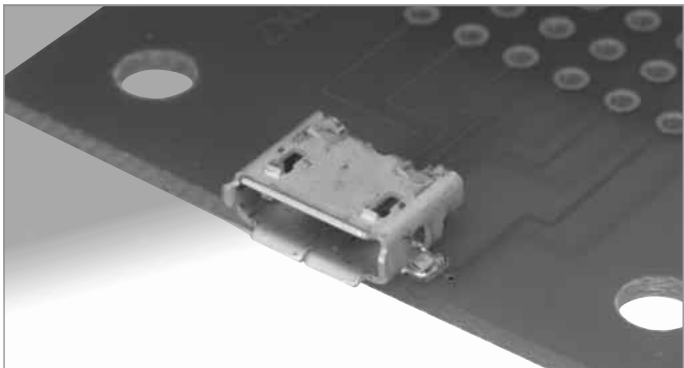

| Part Number | CL No. | Packaging |
|--------------|------------|-----------------------|
| ZX62D-AB-5P8 | 242-0027-5 | 2,000 pieces per reel |

Recommended PCB mounting pattern

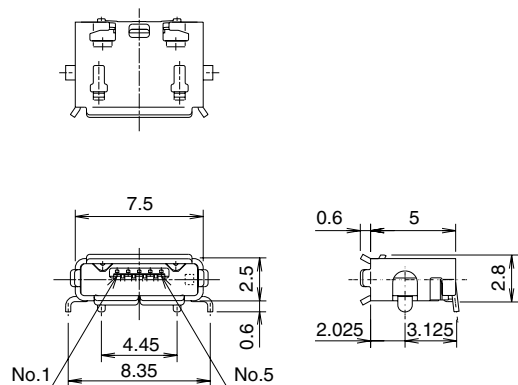
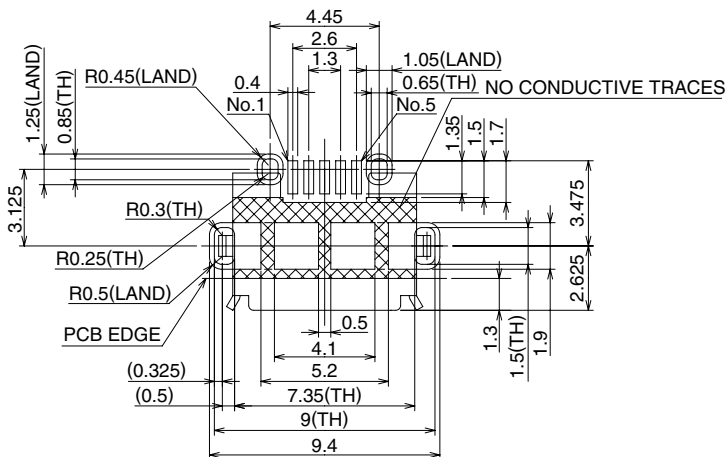

All dimensions: mm

■ Receptacles

● Micro AB - Reverse (Top mount), Shell SMT

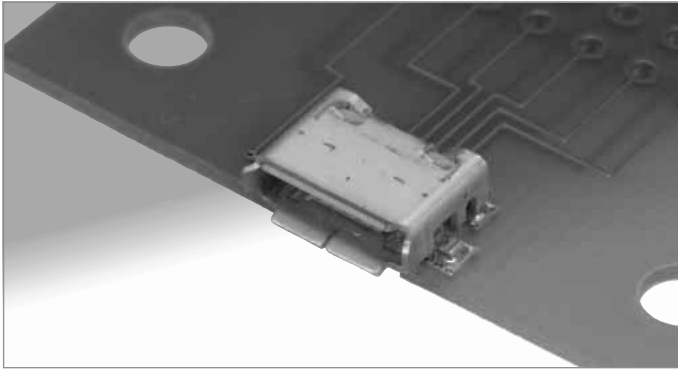

| Part Number | CL No. | Packaging |
|-------------|------------|-----------------------|
| ZX62R-AB-5P | 242-0035-3 | 2,000 pieces per reel |

■ Recommended PCB mounting pattern

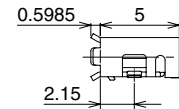
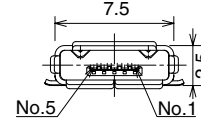
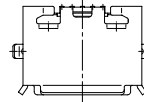
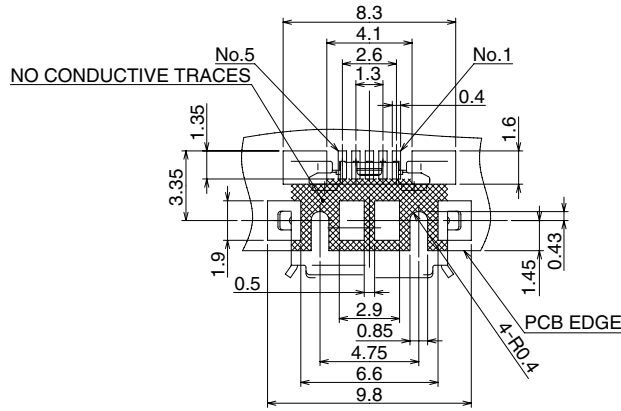

● Micro AB - Reverse (Top mount), Shell through hole

All dimensions: mm

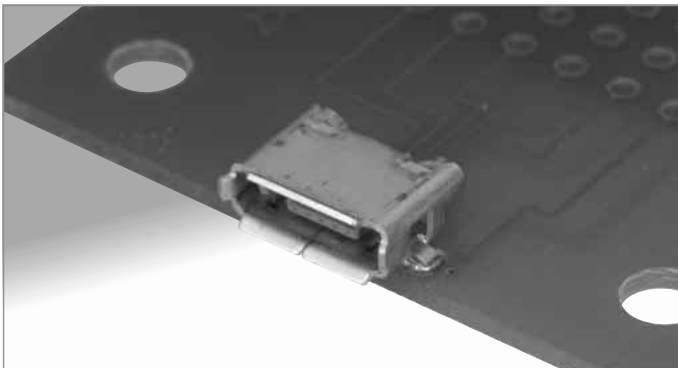





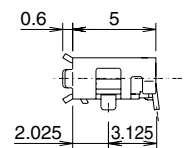
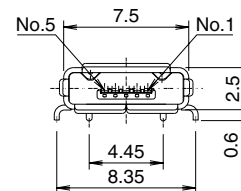
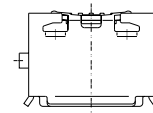
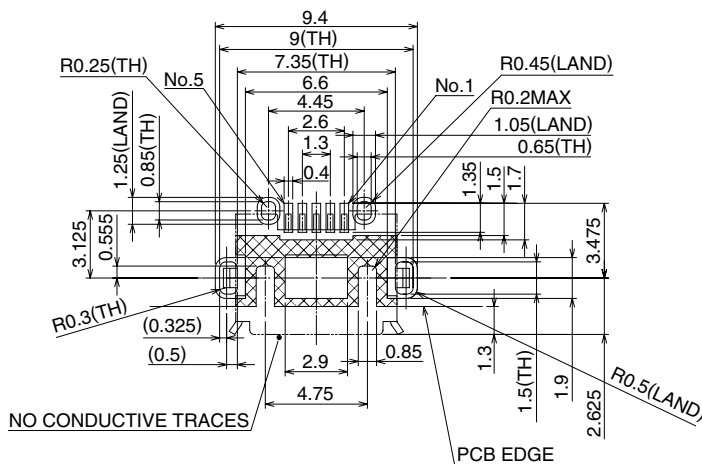



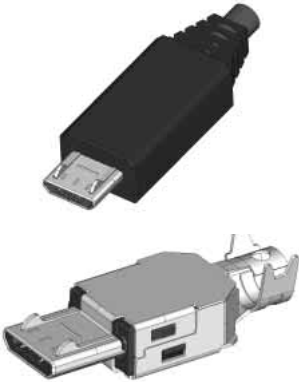
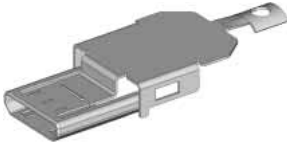

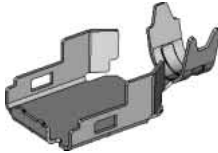

| Part Number | CL No. | Packaging |
|---------------|------------|-----------------------|
| ZX62RD-AB-5P8 | 242-0025-0 | 2,000 pieces per reel |

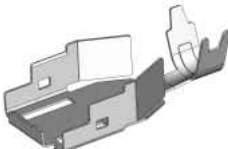
■ Recommended PCB mounting pattern

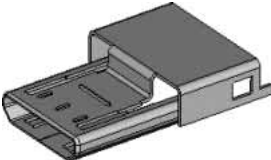

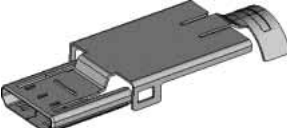
All dimensions: mm

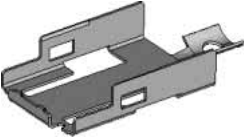
| Plugs – assembled (not-terminated, without overmold) | Components |
|---|---|
| <p data-bbox="236 165 692 204">ZX40 - Direct wire soldering</p>  |  <p data-bbox="1235 242 1469 306">ZX40-*-SLDA Cover-top</p>  <p data-bbox="1235 370 1469 476">ZX40-*-5S-UNIT Assembly (insulator/contacts/lock) *No PCB required</p>  <p data-bbox="1235 512 1469 576">ZX40-SLDB Cover-bottom</p> |
| <p data-bbox="236 638 692 676">ZX10 - PCB wire soldering</p>  |  <p data-bbox="1235 710 1469 774">ZX10-B-SLDA Cover-top</p>  <p data-bbox="1235 838 1469 944">ZX10-B-5S-UNIT Assembly (insulator/contacts/lock) *SMT PCB termination</p>  <p data-bbox="1235 981 1469 1044">ZX10-SLDB Cover-bottom</p> |
| <p data-bbox="236 1117 692 1155">ZX20 - PCB wire soldering</p>  |  <p data-bbox="1235 1204 1469 1268">ZX20-*-SLDC Cover</p>  <p data-bbox="1235 1364 1469 1481">ZX20-*-5S-UNIT Assembly (insulator/contacts/lock) *Straight through hole PCB termination</p> |
| <p data-bbox="236 1527 692 1566">ZX64 - PCB wire soldering</p>  |  <p data-bbox="1235 1598 1469 1661">ZX64-*-SLDA Cover-top</p>  <p data-bbox="1235 1732 1469 1859">ZX64-*-5S-UNIT Assembly (insulator/contacts/lock) *Right angle through hole PCB termination</p>  <p data-bbox="1235 1917 1469 1981">ZX64-SLDB Cover-bottom</p> |

■ Plugs

● Micro B - Assembly (insulator/contacts/lock) – Direct wire soldering



| Part Number | CL No. |
|--------------------|---------------|
| ZX40-B-5S-UNIT(12) | 242-0002-4-12 |

Contact HRS for Cable Termination Procedure Manual.

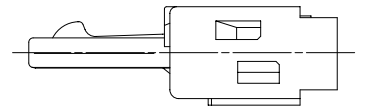
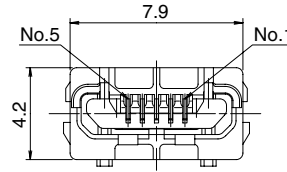
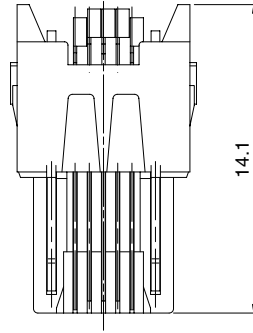

All dimensions: mm

● Micro B - Component, Cover-top - Direct wire soldering

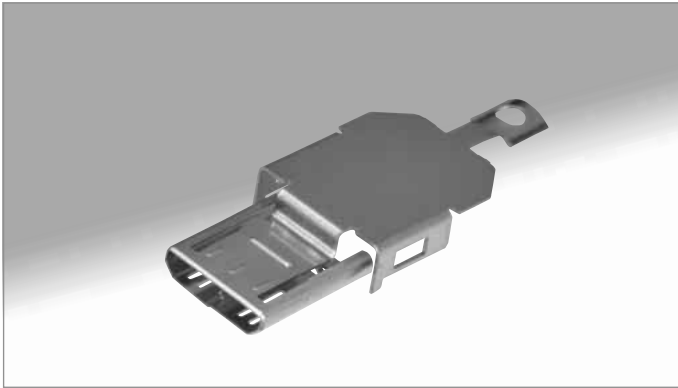

| Part Number | CL No. | Packaging |
|-------------|------------|-----------------------|
| ZX40-B-SLDA | 242-0003-7 | 4,000 pieces per reel |

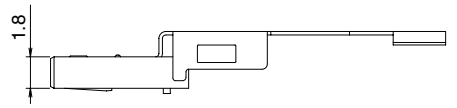
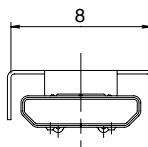
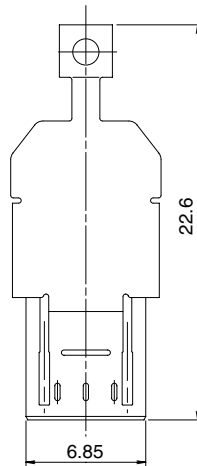

All dimensions: mm

■ Plugs

● Micro A, Micro B - Component, Cover-bottom - Direct wire soldering

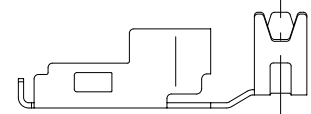
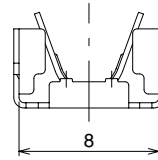
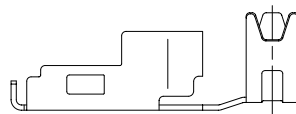
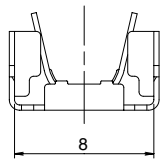
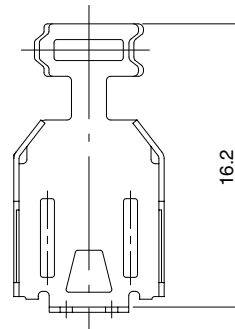
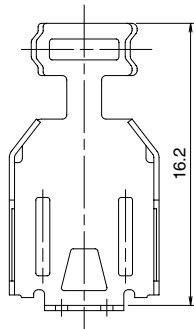
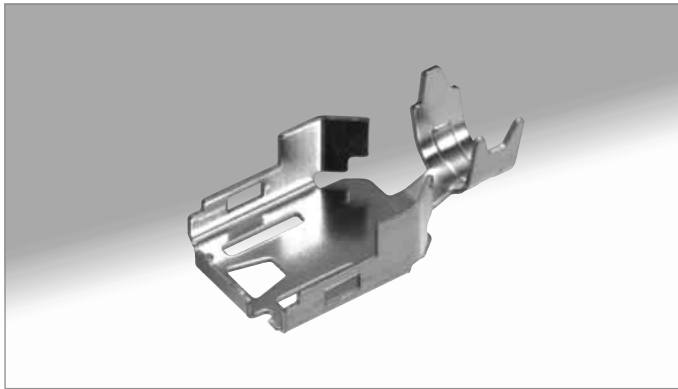

All dimensions: mm

ZX40-SLDB

ZX40-SLDB(3.3)

| Part Number | CL No. | Packaging | Cable dia. |
|----------------|------------|-----------------------|------------|
| ZX40-SLDB | 242-0004-0 | 4,000 pieces per reel | φ3.8 |
| ZX40-SLDB(3.3) | 242-0023-4 | | φ3.3 |

● Assembled

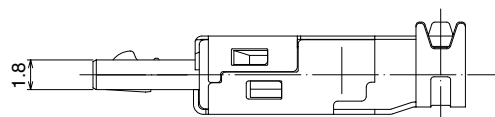
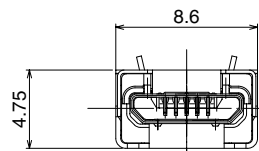
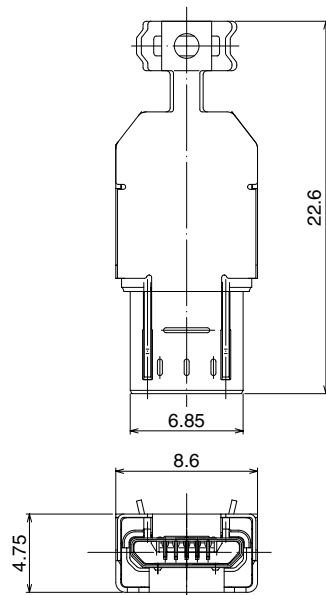

All dimensions: mm

Plugs

● Micro B - Assembly (insulator/contacts/lock) - Right angle through hole PCB wire soldering (non-direct)



| Part Number | CL No. | Packaging |
|--------------------|---------------|-----------------------|
| ZX10-B-5S-UNIT(12) | 242-0030-0-12 | 1,500 pieces per reel |

Contact HRS for Cable Termination Procedure Manual.

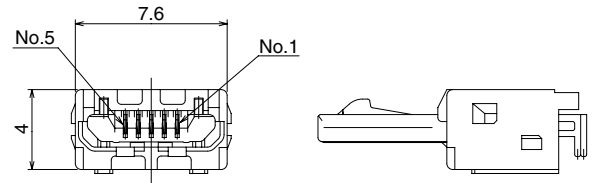
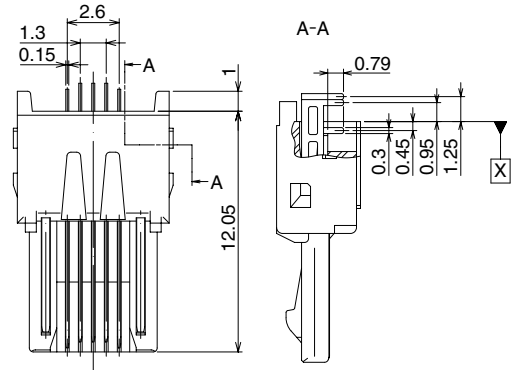
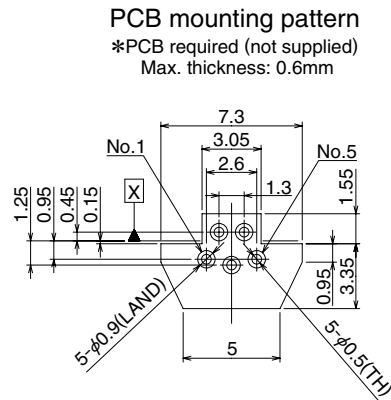

● Micro B - Component, Cover-top - Right angle through hole

All dimensions: mm

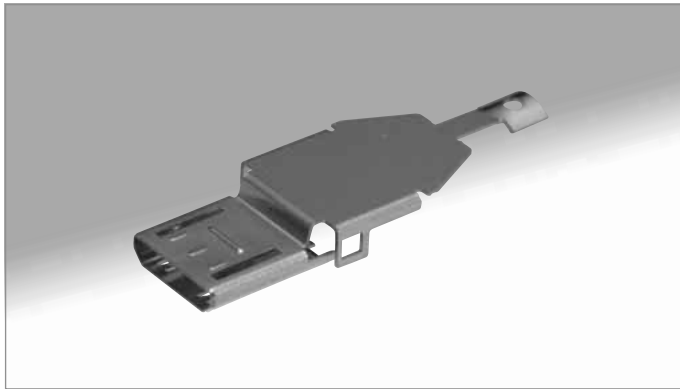

| Part Number | CL No. | Packaging |
|-------------|------------|-----------------------|
| ZX10-B-SLDA | 242-0031-2 | 4,500 pieces per reel |

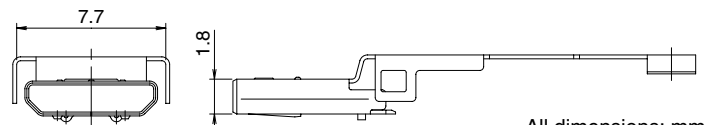
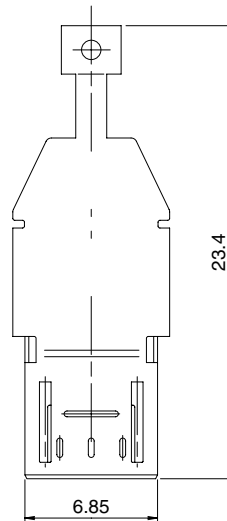

All dimensions: mm

■ Plugs

● Micro B - Component, Cover-bottom – Right angle through hole

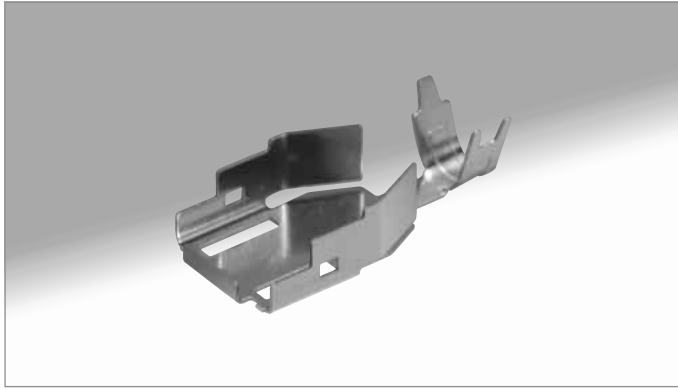

| Part Number | CL No. | Packaging |
|----------------|------------|-----------------------|
| ZX10-SLDB(3.3) | 242-0032-5 | 4,500 pieces per reel |

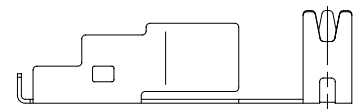
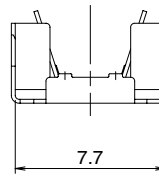
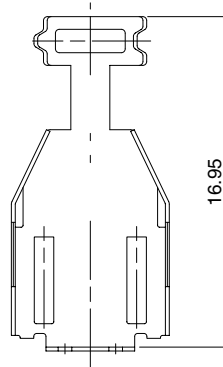

All dimensions: mm

● Assembled

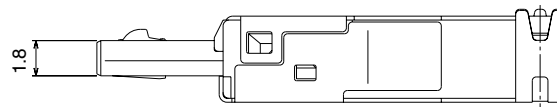
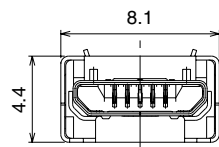
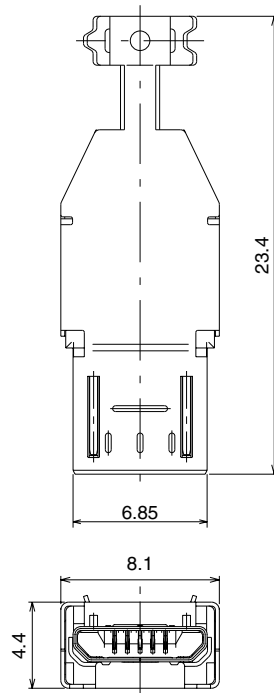

All dimensions: mm

Plugs

● Micro B - Assembly (insulator/contacts/lock) - Straight through hole PCB wire soldering (non-direct)

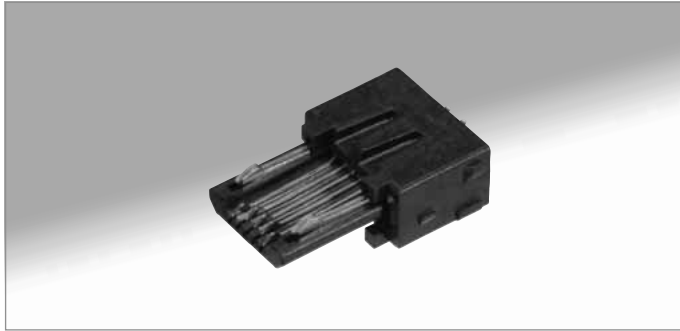

| Part Number | CL No. |
|--------------------|---------------|
| ZX20-B-5S-UNIT(12) | 242-0012-8-12 |

Contact HRS for Cable Termination Procedure Manual.

PCB mounting pattern

*PCB required (not supplied)
 Max. thickness: 0.6mm

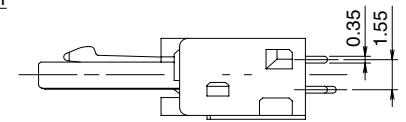
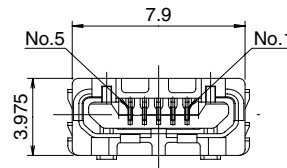
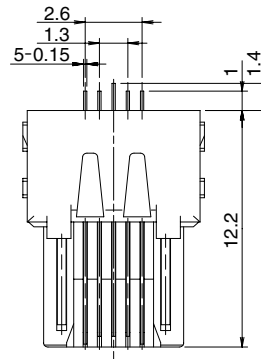
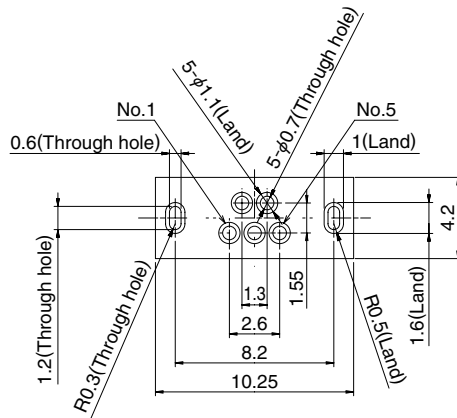

All dimensions: mm

● Micro B - Component, Cover - Straight, through hole

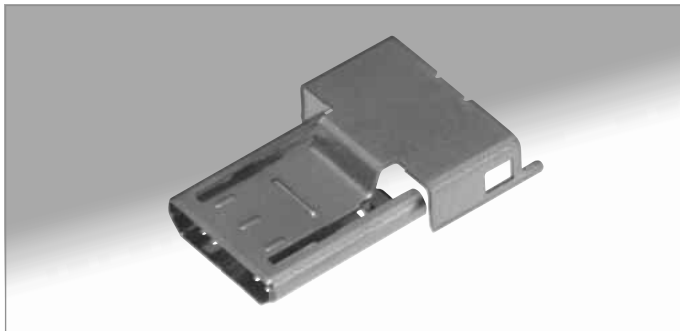

| Part Number | CL No. | Packaging |
|-------------|------------|-----------------------|
| ZX20-B-SLDC | 242-0022-1 | 4,000 pieces per reel |

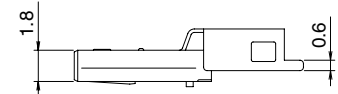
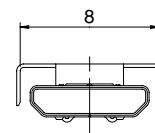
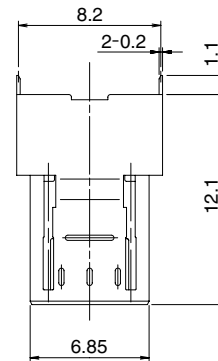

● Assembled

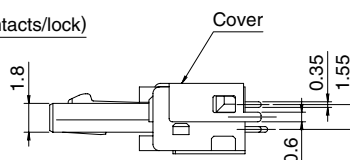
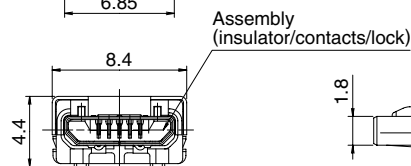
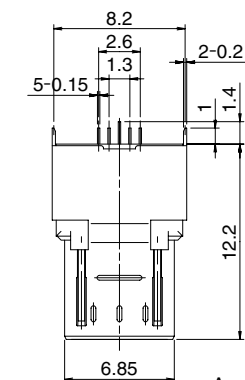

All dimensions: mm

Plugs

● Micro B - Assembly (insulator/contacts/lock) - Right angle SMT



| Part Number | CL No. |
|--------------------|---------------|
| ZX64-B-5S-UNIT(14) | 242-0009-0-14 |

Contact HRS for Cable Termination Procedure Manual.

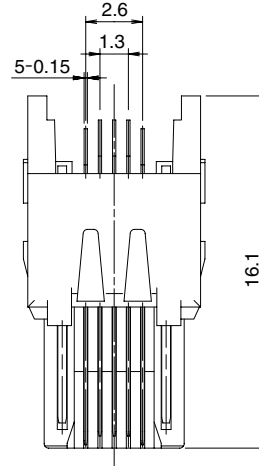

PCB mounting pattern
 *PCB required (not supplied)
 Max. thickness: 1.0mm

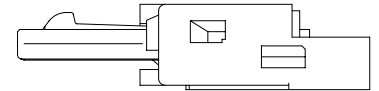
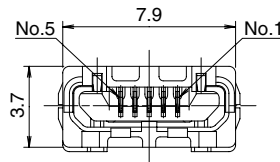
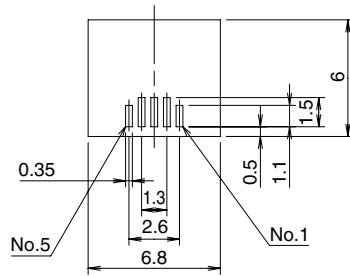

All dimensions: mm

● Micro B - Component, Cover-top – Right angle SMT



| Part Number | CL No. | Packaging |
|-------------|------------|-----------------------|
| ZX64-B-SLDA | 242-0013-0 | 4,000 pieces per reel |

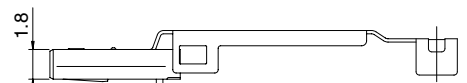
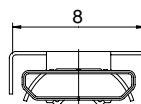
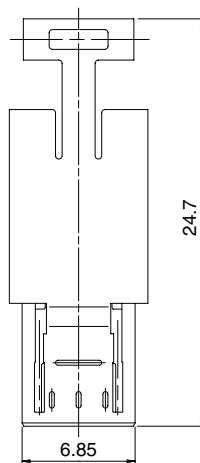

All dimensions: mm

Plugs

● Micro B - Component, Cover-bottom - Right angle SMT

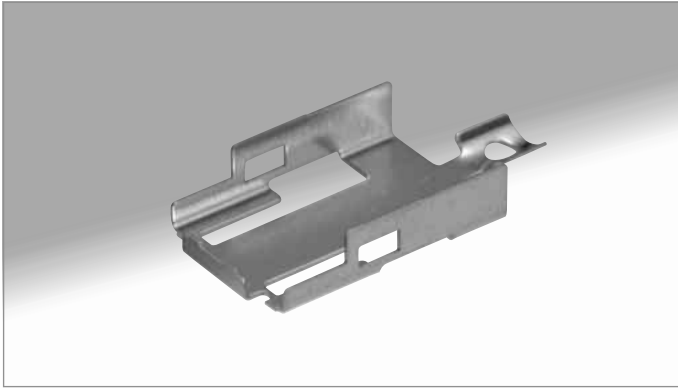

| Part Number | CL No. | Packaging |
|-------------|------------|-----------------------|
| ZX64-SLDB | 242-0049-8 | 4,000 pieces per reel |

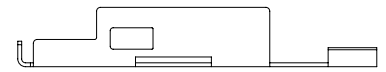
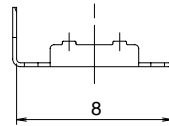
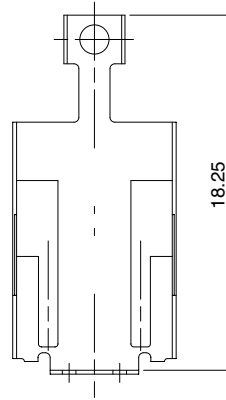

● Assembled

All dimensions: mm

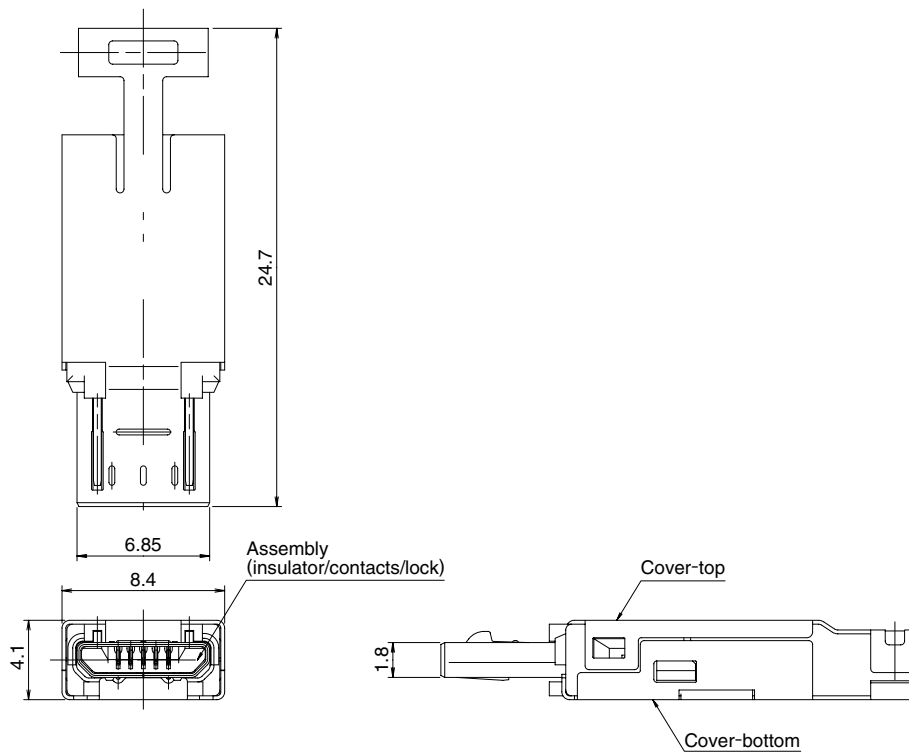

All dimensions: mm

Plugs

● Micro B - Component, Shell/cover – Right angle SMT

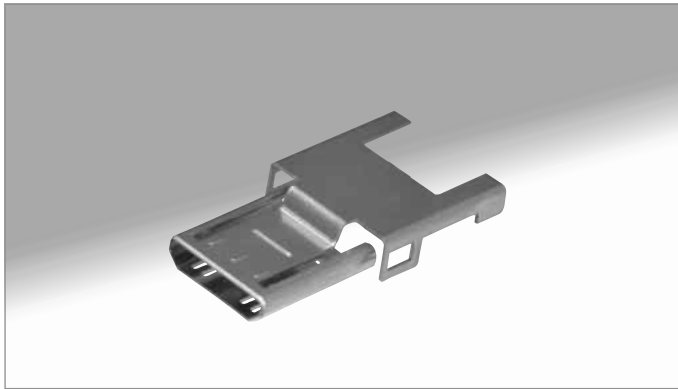

Shell/cover, without cable clamp
 This shell/cover does not require ZX64-SLDB.

| Part Number | CL No. | Packaging |
|-------------|------------|-----------------------|
| ZX64-B-SLDC | 242-0018-4 | 4,000 pieces per reel |

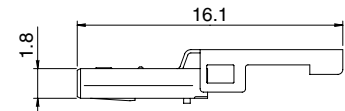
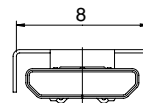
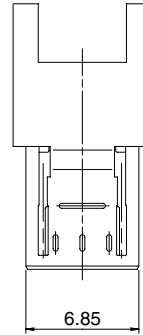

● Assembled

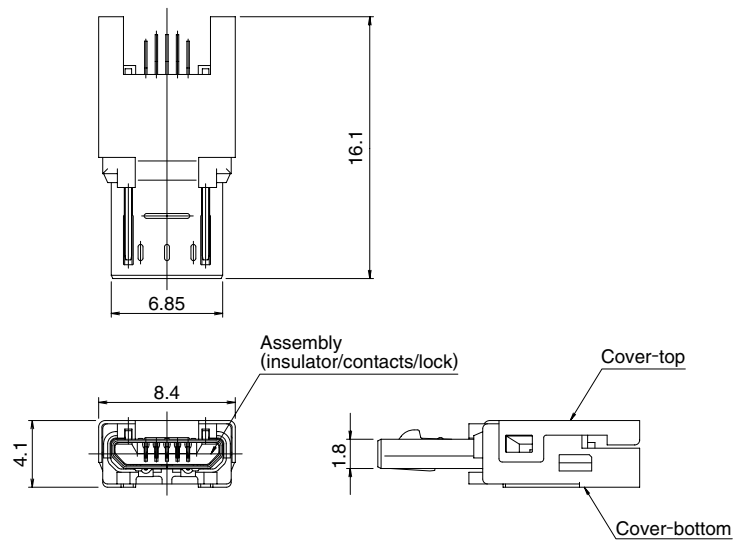

All dimensions: mm

■ Plugs

● Micro A - Assembly (insulator/contacts/lock) - Direct wire soldering

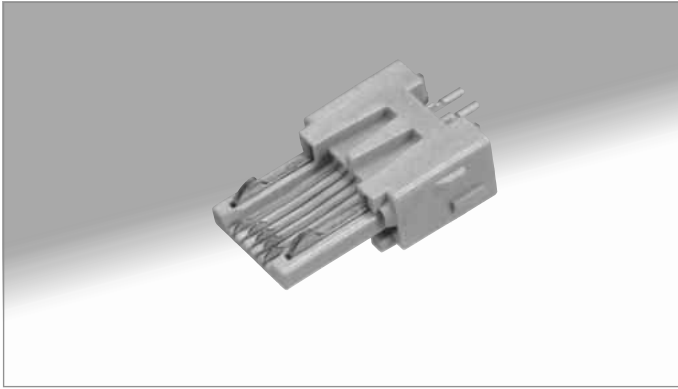

| Part Number | CL No. |
|----------------|------------|
| ZX40-A-5S-UNIT | 242-0010-2 |

Contact HRS for Cable Termination Procedure Manual.

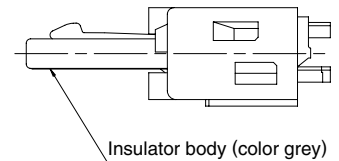
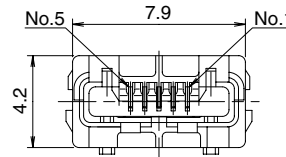
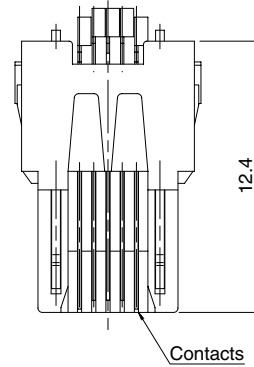
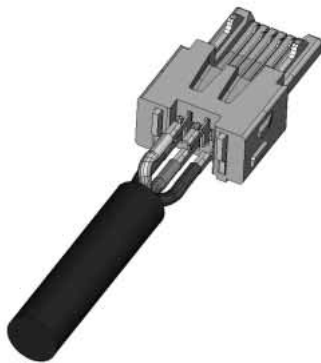

All dimensions: mm

● Micro A - Component, Cover-top - Direct wire soldering

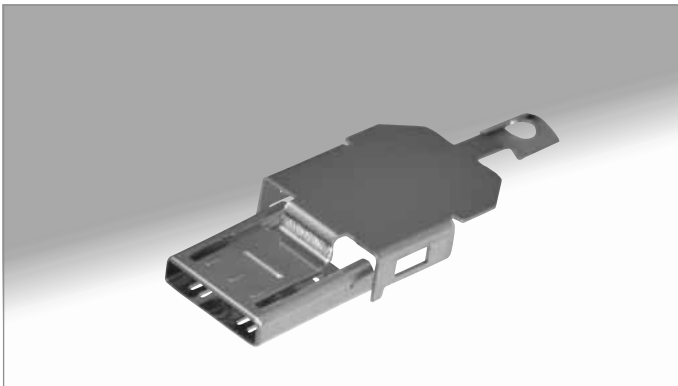

| Part Number | CL No. | Packaging |
|-------------|------------|-----------------------|
| ZX40-A-SLDA | 242-0011-5 | 4,000 pieces per reel |

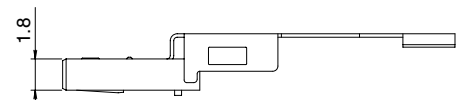
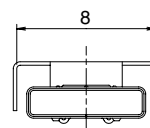
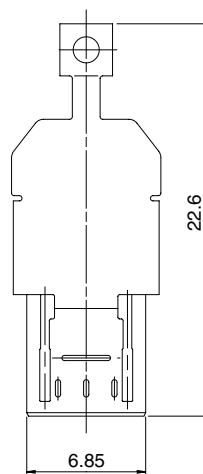

All dimensions: mm

■ Plugs

● Micro A, Micro B - Component, Cover-bottom - Direct wire soldering

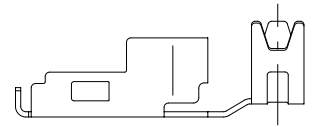
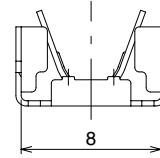
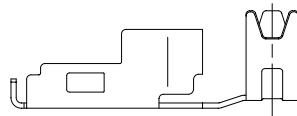
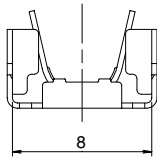
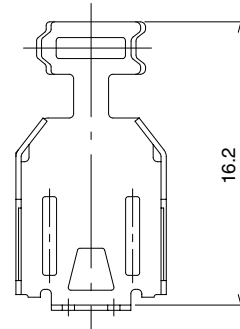
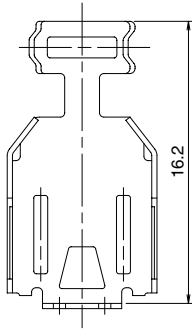
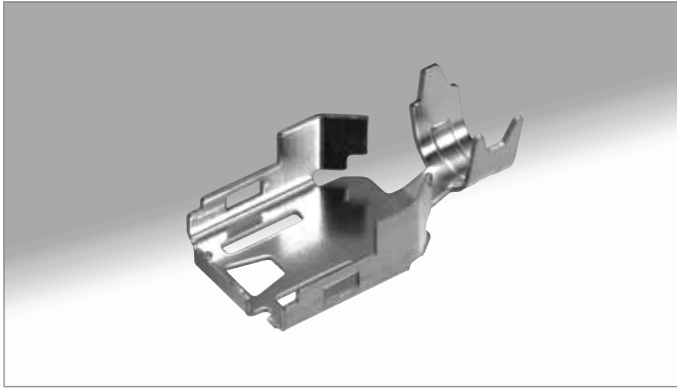

All dimensions: mm

ZX40-SLDB

ZX40-SLDB(3.3)

| Part Number | CL No. | Packaging | Cable dia. |
|----------------|------------|-----------------------|------------|
| ZX40-SLDB | 242-0004-0 | 4,000 pieces per reel | φ3.8 |
| ZX40-SLDB(3.3) | 242-0023-4 | | φ3.3 |

● Assembled

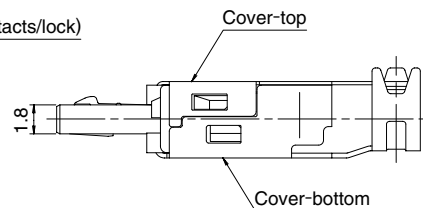
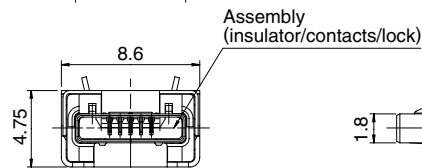
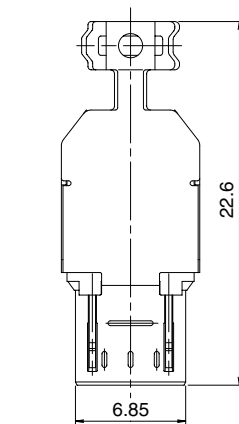

All dimensions: mm

■ Plug-Vertical, cradle mount, Shell through hole

● Micro B, with lock

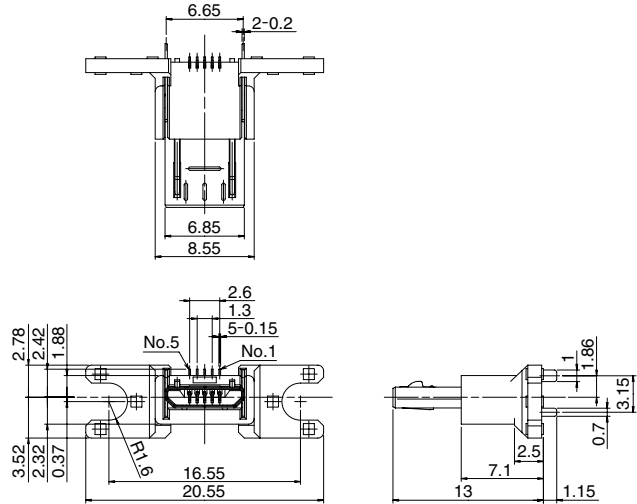
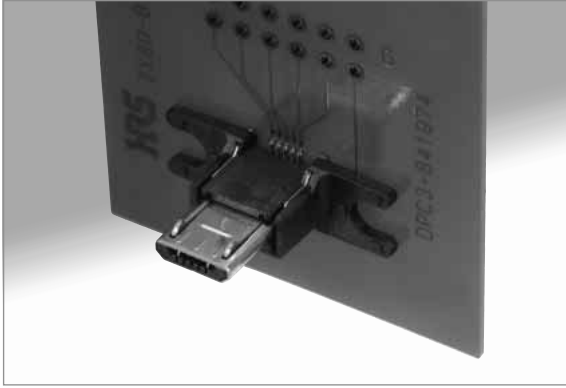

| Part Number | CL No. | Packaging |
|-------------|------------|------------|
| ZX80-B-5S | 242-0017-1 | 100 pieces |

All dimensions: mm

● Micro B, without lock

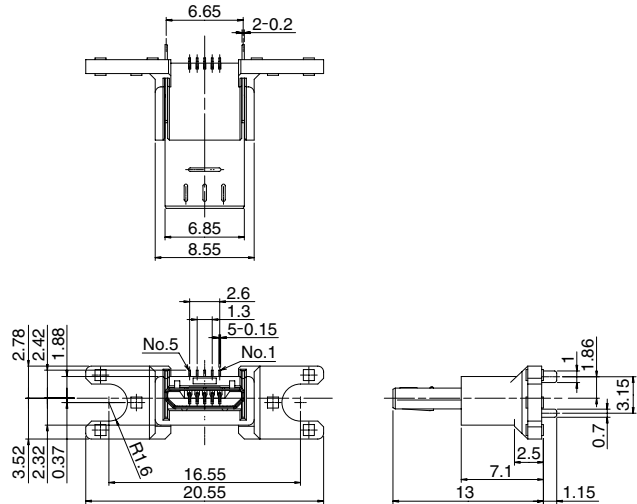
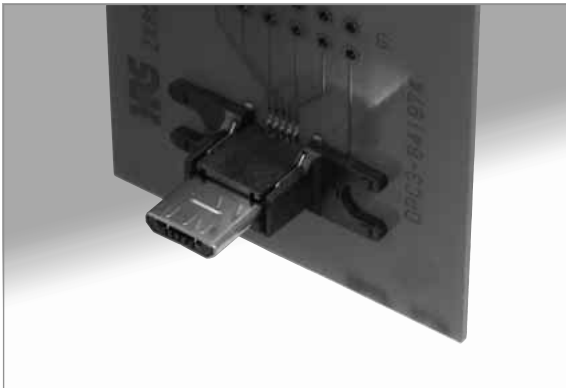

| Part Number | CL No. | Packaging |
|-------------|------------|------------|
| ZX80-B-5SA | 242-0019-7 | 100 pieces |

■ PCB mounting pattern

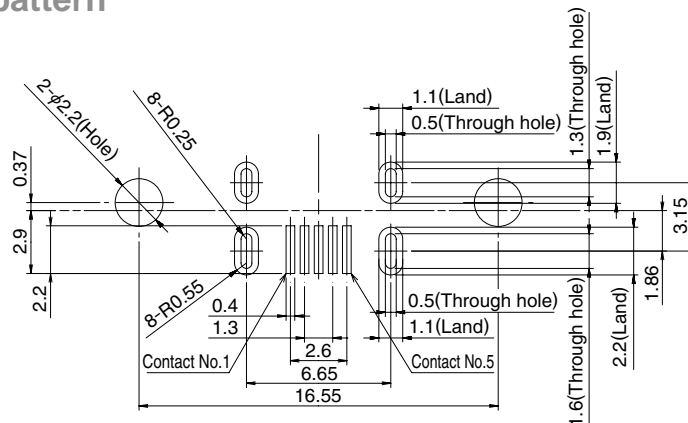

All dimensions: mm

■Packaging Specifications

●Embossed carrier tape dimensions

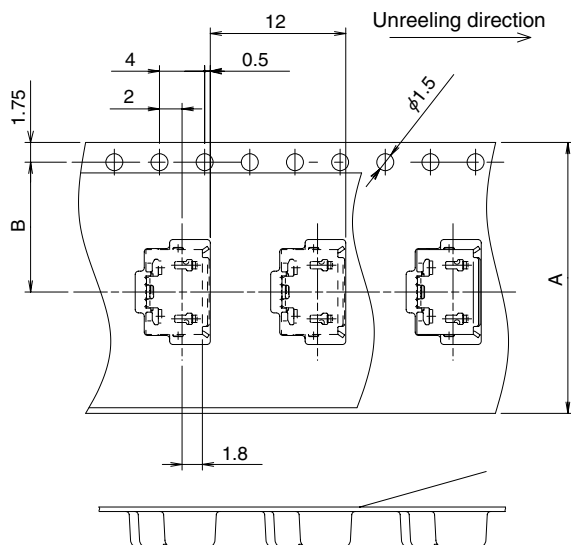

| Part Number | A dimension | B dimension |
|-------------|-------------|-------------|
| ZX62-B-5PA | 24 | 11.5 |
| ZX62-AB-5PA | 24 | 11.5 |
| ZX62M-B-5P | 24 | 11.5 |
| Other | 16 | 7.5 |

●Reel Dimensions

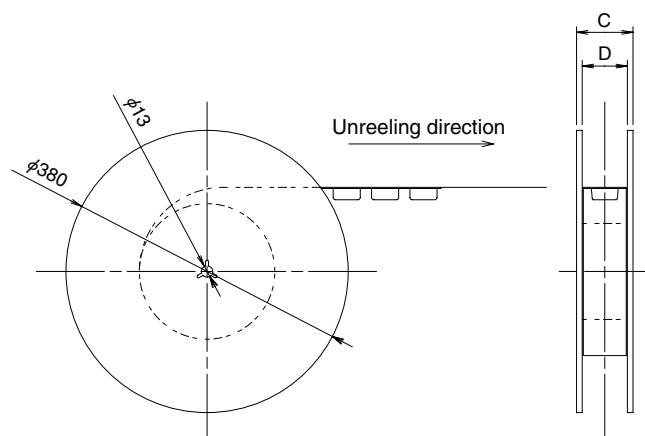

| Part Number | C dimension | D dimension |
|-------------|-------------|-------------|
| ZX62-B-5PA | 30.4 | 24.4 |
| ZX62-AB-5PA | 30.4 | 24.4 |
| ZX62M-B-5P | 30.4 | 24.4 |
| Other | 22.4 | 16.4 |

Note : Tape and reel packaging (2,000 pieces/reel).
 Order by number of reels.

■Recommended Temperature Profile - Receptacles

●Using lead-free solder paste

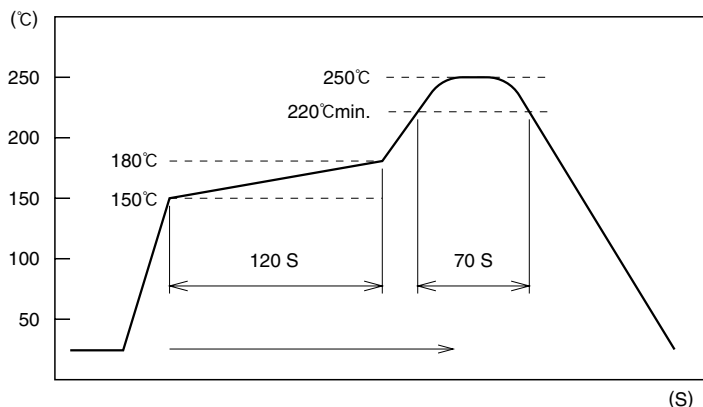

HRS test condition

Solder composition : Paste, 96.5%Sn/3.0%Ag/0.5%Cu

Test board : Glass epoxy 35mm×35mm×0.8mm thick

The temperature profile is based on the left conditions. In individual applications the actual temperature may vary, depending on solder paste type, volume/thickness and board size/thickness. Contact your solder paste and equipment manufacturer for specific recommendations.

Note 1: Up to 2 cycles of Reflow soldering are possible under the same conditions, provided that there is a return to normal temperature between the first and second cycle.

Note 2: The temperature profile indicates the board surface temperature at the point of contacts with the connector terminals.

■Precautions

1. Exercise care when handling the connectors. Do not subject them to excessive external forces when mating/un-mating.
2. Mate and un-mate as intended, holding by the overmolded body, in the correct direction. Do not un-mate by pulling on the cable.
3. Some tooling marks may be visible on the surfaces of receptacle (shell/cover). No form/fit or function is affected.
4. Appearance of the surface finishes on the receptacles may vary between production runs. No affect on form, fit or function.



HIROSE ELECTRIC CO.,LTD.

5-23,OSAKI 5-CHOME,SHINAGAWA-KU,TOKYO 141-8587,JAPAN

PHONE: 81-3-3491-9741, FAX: 81-3-3493-2933

<http://www.hirose.com>

<http://www.hirose-connectors.com>

Компания «Life Electronics» занимается поставками электронных компонентов импортного и отечественного производства от производителей и со складов крупных дистрибьюторов Европы, Америки и Азии.

С конца 2013 года компания активно расширяет линейку поставок компонентов по направлению коаксиальный кабель, кварцевые генераторы и конденсаторы (керамические, пленочные, электролитические), за счёт заключения дистрибьюторских договоров

Мы предлагаем:

- Конкуренспособные цены и скидки постоянным клиентам.
- Специальные условия для постоянных клиентов.
- Подбор аналогов.
- Поставку компонентов в любых объемах, удовлетворяющих вашим потребностям.
- Приемлемые сроки поставки, возможна ускоренная поставка.
- Доставку товара в любую точку России и стран СНГ.
- Комплексную поставку.
- Работу по проектам и поставку образцов.
- Формирование склада под заказчика.
- Сертификаты соответствия на поставляемую продукцию (по желанию клиента).
- Тестирование поставляемой продукции.
- Поставку компонентов, требующих военную и космическую приемку.
- Входной контроль качества.
- Наличие сертификата ISO.

В составе нашей компании организован Конструкторский отдел, призванный помогать разработчикам, и инженерам.

Конструкторский отдел помогает осуществить:

- Регистрацию проекта у производителя компонентов.
- Техническую поддержку проекта.
- Защиту от снятия компонента с производства.
- Оценку стоимости проекта по компонентам.
- Изготовление тестовой платы монтаж и пусконаладочные работы.



Тел: +7 (812) 336 43 04 (многоканальный)
Email: org@lifeelectronics.ru