

# ISDN S-INTERFACE LOW PROFILE DUAL SMT TRANSFORMERS



- RoHS peak reflow temperature rating 245°C
- Meets pulse waveform template of CCITT I.430 when recommended transformer and chip pair are used
- Excellent longitudinal balance
- 2 KVRms isolation voltage
- Available in Tape & Reel or tube packaging
- UL recognized

## Electrical Specifications @ 25°C — Operating Temperature 0°C to 70°C

RoHS Compliant Part Number	Ratio <sup>A</sup> (±2%)		OCL Pri (mH MIN)	L <sub>L</sub> Sec (μH MAX)		CW/W (pF MAX)	CD Pri <sup>B</sup> (pF MAX)		DCR Pri (Ω ±25%)		DCR Sec (W ±25%)		D <sub>Ibc</sub> <sup>C</sup> (mA MAX)
	A	B	A & B	A	B	A & B	A	B	A	B	A	B	
T5005NL	1:2.5	1:2.5	22	40	40	100	110	110	2.4	2.4	5.3	5.3	1
T5007NL	1:2	1:2	22	5	5	100	80	80	2.4	2.4	4.2	4.2	1
T5008NL	1:1	1:1	22	5	5	100	42	42	2.4	2.4	2.4	2.4	1
T5010NL	1:1.8	1:1.8	22	15	15	100	160	160	2.4	2.4	3.8	3.8	1

U.S. Patent No. 5,015,981Z

- A. A center-tapped winding can be created by connecting two ends of a split center winding together on the printed circuit board. In ISDN-S applications, the primary winding is the line side transformer winding.
- B. Minimum primary inductance and maximum distributed capacitance satisfy the transmitter output and receiver input impedance requirements of CCITT I.430 for both the TE and the NT. The maximum distributed capacitance allows sufficient margin for the capacitance of the IC and a protection diode network. It is consistent with the overall maximum value specified and the permitted length of the basic access TE cord.
- C. The maximum specified unbalanced DC current capability is based on 20 mH minimum primary OCL.

See next page for detailed packaging information.

## Mechanical

### TSJ

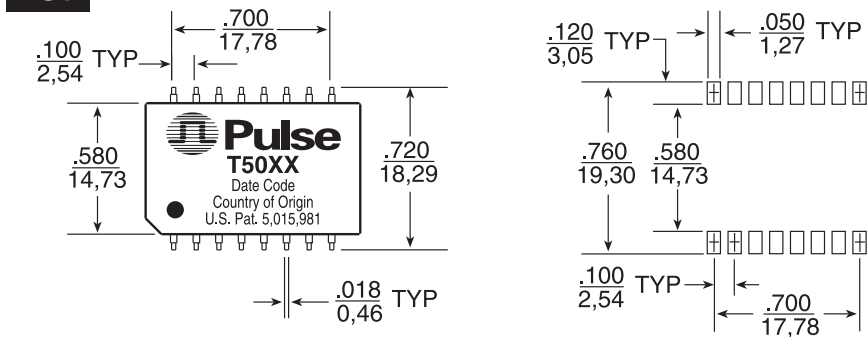

### SUGGESTED PAD LAYOUT

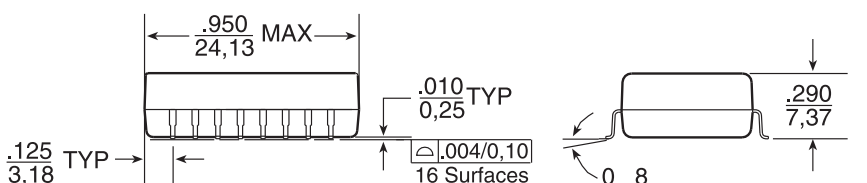

## Schematic

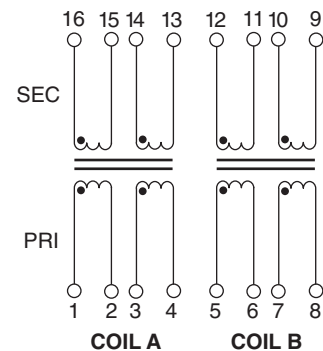

Dimensions:  $\frac{\text{Inches}}{\text{mm}}$   
Unless otherwise specified all tolerances are  $\pm .010$  /  $0,25$

# ISDN S-INTERFACE LOW PROFILE DUAL SMT TRANSFORMERS



IC Manufacturer	IC Part Number	Dual Surface Mount
<b>TX &amp; RX</b>		
<b>AT&amp;T/Lucent</b>	T7250/7256/7259	T5005NL
<b>Mietec</b>	T7903 MTC-2072	T5007NL T5007NL
<b>Mitel</b>	MT8930	T5007NL
<b>Motorola</b>	MC145474/145475 MC145574	T5008NL T5005NL
<b>National*</b>	TP3420/3421	T5007NL
<b>SGS Thomson</b>	ST5420, ST5421	T5007NL
<b>Siemens</b>	PEB 2080/2081/2085 PSB 2186 PEB 2084/2086	T5007NL
<b>Yamaha</b>	7405B, YTD421	T5007NL
<b>B</b>	29C53	T5010NL

\*NOTE: National recommends a 1:2 receive transformer, but used as a 1:1 ratio by connecting only half the secondary winding.

<b>Packaging Information</b>	
<b>Type</b>	SMT
<b>Part Weight</b>	7 grams
<b>Parts/Tube</b>	20
<b>Parts/Tray*</b>	50
<b>Parts/Reel*</b>	200
<b>Reel Diameter</b>	13 inches
<b>Tape Width</b>	44 mm
<b>Pitch</b>	24 mm

\*NOTE: Standard packaging for all transformers on this data sheet is anti-static tubes. Optional Tape & Reel packaging can be ordered by adding a "T" suffix to the end of the part number, (i.e: T5005NLT).

## Application Notes

**1. General Information** – The S-interface is the standardized four-wire digital telephone access point defined by the CCITT I-series recommendations for the Integrated Services Digital Network. This "basic rate access" accommodates two 64 Kbps "B-channels" for information, one 16Kbps "D-channel" intended for signaling and control, and 48Kbps for framing and other purposes, giving a total rate of 192Kbps. The CCITT physical layer recommends that the user network interface be transformer coupled.

The transformer provides isolation for the line card or the terminal from the line. It is also a way to provide phantom power feeding to the terminal over the S-loop. Each end requires a transmit and a receive transformer. Chokes are used in some applications to reduce common mode noise.

Transformers described in this data sheet are matched to the transceivers offered by the IC manufacturers listed.

The use of a transformer-chip pair assures that all requirements of CCITT I.430 are met with respect to pulse waveform templates, impedance and longitudinal balance. In addition, the transformers provide the isolation voltages required by the regulatory agencies and are capable of passing surge voltage tests.

- 2. Safety Standards Recognition** – All transformers listed in this data sheet are recognized to UL 1459 and UL 1950 as a basic insulation barrier.
- 3. Flammability** – Materials used in the products are recognized UL94-VO. Products meet the requirements of IEC 695-2-2 (needle flame test).
- 4. For more** application notes please refer to data sheet T604.

## Common Mode Chokes

Refer to data sheet G002 for selection of low and high frequency common mode chokes.

## For More Information:

### Pulse Worldwide Headquarters

12220 World Trade Dr.  
San Diego, CA 92128  
U.S.A.

[www.pulseeng.com](http://www.pulseeng.com)

Tel: 858 674 8100  
Fax: 858 674 8262

### Pulse Europe

Einsteinstrasse 1  
D-71083 Herrenberg  
Germany

Tel: 49 7032 7806 0  
Fax: 49 7032 7806 135

### Pulse China Headquarters

B402, Shenzhen Academy of  
Aerospace Technology Bldg.  
10th Kejinan Rd.  
High-Tech Zone  
Nanshan District  
Shenzhen, PR China 518057

Tel: 86 755 33966678  
Fax: 86 755 33966700

### Pulse North China

Room 2704/2705  
Super Ocean Finance Ctr.  
2067 Yan An Rd. West  
Shanghai 200336  
China

Tel: 86 21 62787060  
Fax: 86 2162786973

### Pulse South Asia

135 Joo Seng Rd.  
#03-02  
PM Industrial Bldg.  
Singapore 368363

Tel: 65 6287 8998  
Fax: 65 6287 8998

### Pulse North Asia

3F, No. 198  
Zhongyuan Rd.  
Zhongli City  
Taoyuan County 320  
Taiwan R. O. C.

Tel: 886 3 4356768  
Fax: FRE 886 3 4356820  
Pulse: 886 3 4356823

Performance warranty of products offered on this data sheet is limited to the parameters specified. Data is subject to change without notice. Other brand and product names mentioned herein may be trademarks or registered trademarks of their respective owners.

© Copyright, 2009. Pulse Engineering, Inc. All rights reserved.

[www.pulseeng.com](http://www.pulseeng.com)

Компания «Life Electronics» занимается поставками электронных компонентов импортного и отечественного производства от производителей и со складов крупных дистрибьюторов Европы, Америки и Азии.

С конца 2013 года компания активно расширяет линейку поставок компонентов по направлению коаксиальный кабель, кварцевые генераторы и конденсаторы (керамические, пленочные, электролитические), за счёт заключения дистрибьюторских договоров

Мы предлагаем:

- Конкурентоспособные цены и скидки постоянным клиентам.
- Специальные условия для постоянных клиентов.
- Подбор аналогов.
- Поставку компонентов в любых объемах, удовлетворяющих вашим потребностям.
- Приемлемые сроки поставки, возможна ускоренная поставка.
- Доставку товара в любую точку России и стран СНГ.
- Комплексную поставку.
- Работу по проектам и поставку образцов.
- Формирование склада под заказчика.
- Сертификаты соответствия на поставляемую продукцию (по желанию клиента).
- Тестирование поставляемой продукции.
- Поставку компонентов, требующих военную и космическую приемку.
- Входной контроль качества.
- Наличие сертификата ISO.

В составе нашей компании организован Конструкторский отдел, призванный помогать разработчикам, и инженерам.

Конструкторский отдел помогает осуществить:

- Регистрацию проекта у производителя компонентов.
- Техническую поддержку проекта.
- Защиту от снятия компонента с производства.
- Оценку стоимости проекта по компонентам.
- Изготовление тестовой платы монтаж и пусконаладочные работы.



Тел: +7 (812) 336 43 04 (многоканальный)  
Email: [org@lifeelectronics.ru](mailto:org@lifeelectronics.ru)