

Description

The 9ZXL1530D / 9ZXL1550D are second-generation enhanced-performance DB1900Z-derivative differential buffers. The parts are pin-compatible upgrades to the 9ZXL1530B and 9ZXL1550B, while offering a much improved phase jitter performance. A fixed external feedback maintains low drift for critical QPI/UPI applications. In fanout mode, the devices meet the DB2000Q additive phase jitter specification.

PCIe Clocking Architectures

- Common Clocked (CC)
- Independent Reference (IR) with and without spread spectrum

Typical Applications

- Servers
- Storage
- Networking
- SSDs

Output Features

- 15 Low-Power HCSL (LP-HCSL) output pairs (1530D)
- 15 Low-Power HCSL (LP-HCSL) output pairs with 85Ω Zout (1550D)

Block Diagram

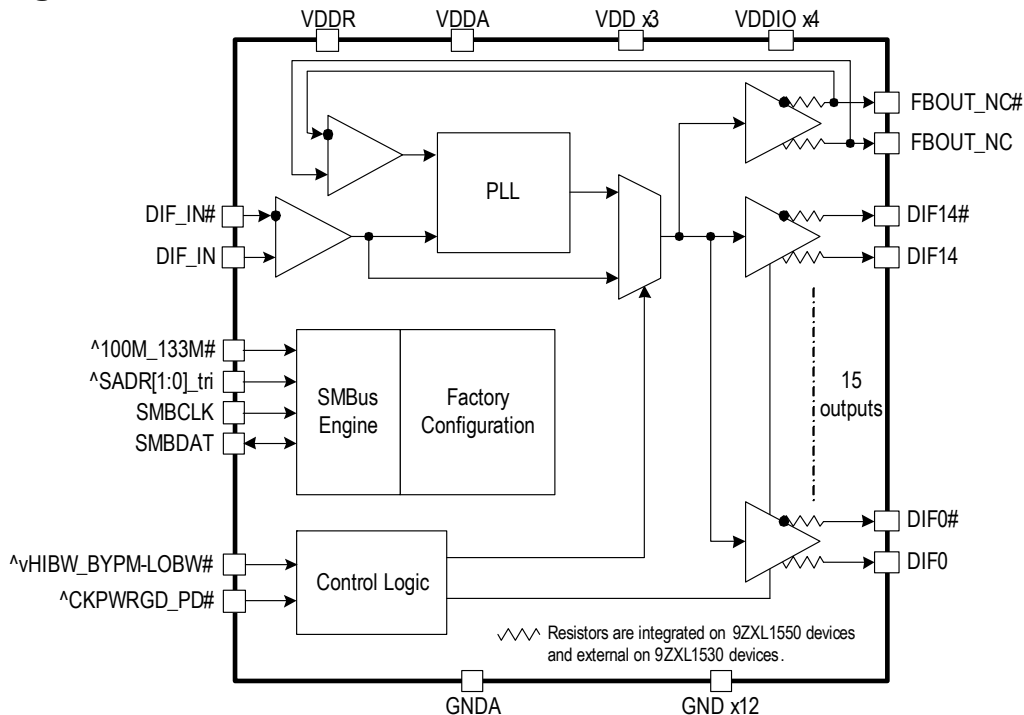

Features

- LP-HCSL outputs; eliminate 30 resistors, save 51mm² of area (1530D)
- LP-HCSL outputs with 85Ω Zout; eliminate 60 resistors, save 103mm² of area (1550D)
- SMBus OE bits; software control of each output
- 9 selectable SMBus addresses; multiple devices can share the same SMBus segment
- Selectable PLL BW; minimizes jitter peaking in cascaded PLL topologies
- Hardware/SMBus control of PLL bandwidth and bypass; change mode without power cycle
- Spread spectrum compatible; tracks spreading input clock for EMI reduction
- 9 × 9 mm 64-VFQFPN package; small board footprint

Key Specifications

- Cycle-to-cycle jitter: < 50ps
- Output-to-output skew: < 50ps
- Input-to-output delay: fixed at 0ps
- Input-to-output delay variation: < 50ps
- Additive phase jitter: PCIe Gen4 < 53fs rms
- Additive phase jitter: IF-UPI < 70fs rms
- Additive phase jitter: DB2000Q filter < 80fs rms

Contents

| | |
|--|----|
| Description | 1 |
| PCIe Clocking Architectures | 1 |
| Typical Applications | 1 |
| Output Features | 1 |
| Features | 1 |
| Key Specifications | 1 |
| Block Diagram | 1 |
| Pin Assignments | 3 |
| Pin Descriptions | 3 |
| Electrical Characteristics | 6 |
| Clock Periods | 14 |
| Functionality at Power-Up (PLL Mode) | 15 |
| Test Loads | 16 |
| Package Outline Drawings | 20 |
| Ordering Information | 20 |
| Revision History | 21 |

Pin Assignments

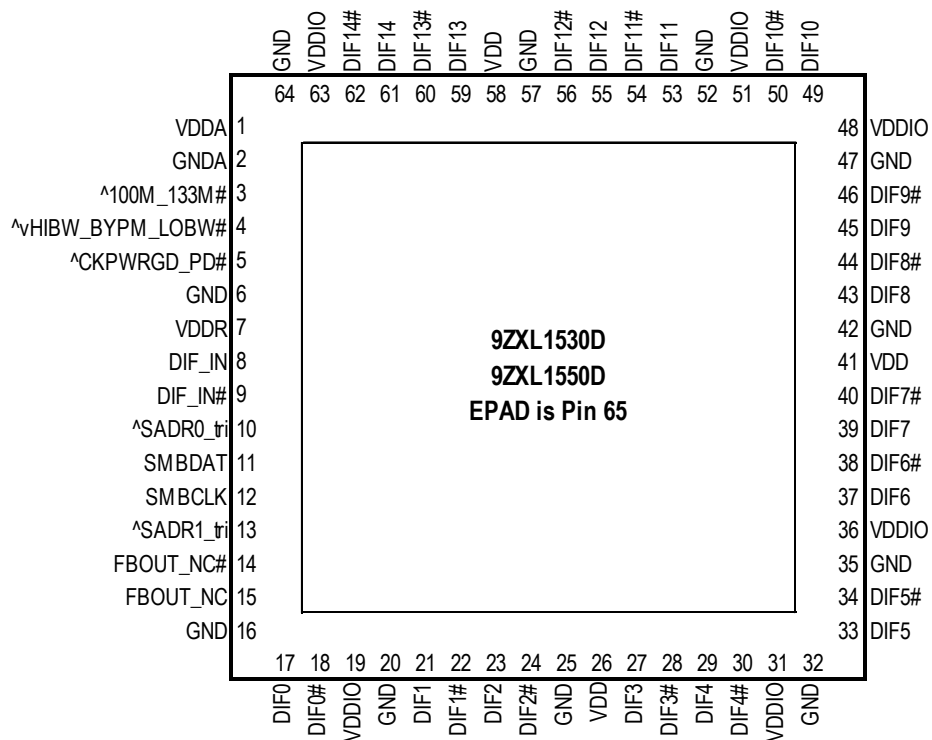

9 x 9 mm 64-VFQFPN

Notes: Pins with ^ prefix have internal 120kohm pull-up
 Pins with v prefix have internal 120kohm pull-down
 Pins with ^v prefix have internal 120kohm pull-up/pull-down (biased to VDD/2)

Pin Descriptions

Table 1. Pin Descriptions

| Number | Name | Type | Description |
|--------|-------------------|------------|---|
| 1 | VDDA | Power | Power supply for PLL core. |
| 2 | GNDA | GND | Ground pin for the PLL core. |
| 3 | ^100M_133M# | Latched In | 3.3V input to select operating frequency. This pin has an internal 120kΩ pull-up resistor. See <i>Functionality at Power-Up</i> table for definition. |
| 4 | ^vHIBW_BYPM_LOBW# | Latched In | Tri-level input to select High BW, Bypass or Low BW mode. This pin is biased to V _{DD} /2 (Bypass Mode) with internal pull-up/pull-down resistors. See <i>PLL Operating Mode</i> table for details. |
| 5 | ^CKPWRGD_PD# | Input | Input notifies device to sample latched inputs and start up on first high assertion. Low enters Power Down Mode, subsequent high assertions exit Power Down Mode. This pin has internal 120kΩ pull-up resistor. |
| 6 | GND | GND | Ground pin. |
| 7 | VDDR | Power | Power supply for differential input clock (receiver). This V _{DD} should be treated as an analog power rail and filtered appropriately. Nominally 3.3V. |
| 8 | DIF_IN | Input | HCSL true input. |
| 9 | DIF_IN# | Input | HCSL complementary input. |

Table 1. Pin Descriptions (Cont.)

| Number | Name | Type | Description |
|--------|------------|--------|---|
| 10 | ^SADR0_tri | Input | SMBus address bit. This is a tri-level input that works in conjunction with other SADR pins, if present, to decode SMBus Addresses. It has an internal 120kΩ pull-up resistor. See the <i>SMBus Addressing</i> table. |
| 11 | SMBDAT | I/O | Data pin of SMBUS circuitry. |
| 12 | SMBCLK | Input | Clock pin of SMBUS circuitry. |
| 13 | ^SADR1_tri | Input | SMBus address bit. This is a tri-level input that works in conjunction with other SADR pins, if present, to decode SMBus Addresses. It has an internal 120kΩ pull-up resistor. See the <i>SMBus Addressing</i> table. |
| 14 | FBOUT_NC# | Output | Complementary half of differential feedback output. This pin should NOT be connected to anything outside the chip. It exists to provide delay path matching to get 0 propagation delay. |
| 15 | FBOUT_NC | Output | True half of differential feedback output. This pin should NOT be connected to anything outside the chip. It exists to provide delay path matching to get 0 propagation delay. |
| 16 | GND | GND | Ground pin. |
| 17 | DIF0 | Output | Differential true clock output. |
| 18 | DIF0# | Output | Differential complementary clock output. |
| 19 | VDDIO | Power | Power supply for differential outputs. |
| 20 | GND | GND | Ground pin. |
| 21 | DIF1 | Output | Differential true clock output. |
| 22 | DIF1# | Output | Differential complementary clock output. |
| 23 | DIF2 | Output | Differential true clock output. |
| 24 | DIF2# | Output | Differential complementary clock output. |
| 25 | GND | GND | Ground pin. |
| 26 | VDD | Power | Power supply, nominally 3.3V. |
| 27 | DIF3 | Output | Differential true clock output. |
| 28 | DIF3# | Output | Differential complementary clock output. |
| 29 | DIF4 | Output | Differential true clock output. |
| 30 | DIF4# | Output | Differential complementary clock output. |
| 31 | VDDIO | Power | Power supply for differential outputs. |
| 32 | GND | GND | Ground pin. |
| 33 | DIF5 | Output | Differential true clock output. |
| 34 | DIF5# | Output | Differential complementary clock output. |
| 35 | GND | GND | Ground pin. |
| 36 | VDDIO | Power | Power supply for differential outputs. |
| 37 | DIF6 | Output | Differential true clock output. |
| 38 | DIF6# | Output | Differential complementary clock output. |
| 39 | DIF7 | Output | Differential true clock output. |

Table 1. Pin Descriptions (Cont.)

| Number | Name | Type | Description |
|--------|--------|--------|--|
| 40 | DIF7# | Output | Differential complementary clock output. |
| 41 | VDD | Power | Power supply, nominally 3.3V. |
| 42 | GND | GND | Ground pin. |
| 43 | DIF8 | Output | Differential true clock output. |
| 44 | DIF8# | Output | Differential complementary clock output. |
| 45 | DIF9 | Output | Differential true clock output. |
| 46 | DIF9# | Output | Differential complementary clock output. |
| 47 | GND | GND | Ground pin. |
| 48 | VDDIO | Power | Power supply for differential outputs. |
| 49 | DIF10 | Output | Differential true clock output. |
| 50 | DIF10# | Output | Differential complementary clock output. |
| 51 | VDDIO | Power | Power supply for differential outputs. |
| 52 | GND | GND | Ground pin. |
| 53 | DIF11 | Output | Differential true clock output. |
| 54 | DIF11# | Output | Differential complementary clock output. |
| 55 | DIF12 | Output | Differential true clock output. |
| 56 | DIF12# | Output | Differential complementary clock output. |
| 57 | GND | GND | Ground pin. |
| 58 | VDD | PWR | Power supply, nominally 3.3V. |
| 59 | DIF13 | Output | Differential true clock output. |
| 60 | DIF13# | Output | Differential complementary clock output. |
| 61 | DIF14 | Output | Differential true clock output. |
| 62 | DIF14# | Output | Differential complementary clock output. |
| 63 | VDDIO | Power | Power supply for differential outputs. |
| 64 | GND | GND | Ground pin. |
| 65 | EPAD | GND | EPAD should be connected to GND. |

Absolute Maximum Ratings

Stresses above the ratings listed below can cause permanent damage to the 9ZXL1530D / 9ZXL1550D. These ratings, which are standard values for IDT commercially rated parts, are stress ratings only. Functional operation of the device at these or any other conditions above those indicated in the operational sections of the specifications is not implied. Exposure to absolute maximum rating conditions for extended periods can affect product reliability. Electrical parameters are guaranteed only over the recommended operating temperature range.

Table 2. Absolute Maximum Ratings

| Parameter | Symbol | Conditions | Minimum | Typical | Maximum | Units | Notes |
|---------------------------|-------------|-----------------------------|-----------|---------|----------------|-------|-------|
| Supply Voltage | V_{DDx} | | | | 3.9 | V | 1,2 |
| Input Low Voltage | V_{IL} | | GND - 0.5 | | | V | 1 |
| Input Low Voltage | V_{IH} | Except for SMBus interface. | | | $V_{DD} + 0.5$ | V | 1,3 |
| Input High Voltage, SMBus | V_{IHSMB} | SMBus clock and data pins. | | | 3.9 | V | 1 |
| Storage Temperature | T_s | | -65 | | 150 | °C | 1 |
| Junction Temperature | T_j | | | | 125 | °C | 1 |
| Input ESD Protection | ESD prot | Human Body Model. | 2000 | | | V | 1 |

¹ Guaranteed by design and characterization, not 100% tested in production.

² Operation under these conditions is neither implied nor guaranteed.

³ Not to exceed 3.9V.

Electrical Characteristics

T_{AMB} = over the specified operating range. Supply voltages per normal operation conditions; see Test Loads for loading conditions.

Table 3. SMBus Parameters

| Parameter | Symbol | Conditions | Minimum | Typical | Maximum | Units | Notes |
|---------------------------|--------------|---|---------|---------|-------------|-------|-------|
| SMBus Input Low Voltage | V_{ILSMB} | | | | 0.8 | V | |
| SMBus Input High Voltage | V_{IHSMB} | | 2.1 | | V_{DDSMB} | V | |
| SMBus Output Low Voltage | V_{OLSMB} | At I_{PULLUP} . | | | 0.4 | V | |
| SMBus Sink Current | I_{PULLUP} | At V_{OL} . | 4 | | | mA | |
| Nominal Bus Voltage | V_{DDSMB} | | 2.7 | | 3.6 | V | 1 |
| SCLK/SDATA Rise Time | t_{RSMB} | (Max $V_{IL} - 0.15V$) to (Min $V_{IH} + 0.15V$). | | | 1000 | ns | 1 |
| SCLK/SDATA Fall Time | t_{FSMB} | (Min $V_{IH} + 0.15V$) to (Max $V_{IL} - 0.15V$). | | | 300 | ns | 1 |
| SMBus Operating Frequency | f_{SMBMAX} | Maximum SMBus operating frequency. | | | 400 | kHz | 5 |

¹ Guaranteed by design and characterization, not 100% tested in production.

² Control input must be monotonic from 20% to 80% of input swing.

³ Time from deassertion until outputs are > 200mV.

⁴ DIF_IN input.

⁵ The differential input clock must be running for the SMBus to be active.

Table 4. DIF_IN Clock Input Parameters

| Parameter | Symbol | Conditions | Minimum | Typical | Maximum | Units | Notes |
|----------------------------------|-------------|---|---------|---------|---------|---------|-------|
| Input Crossover Voltage – DIF_IN | V_{CROSS} | Cross over voltage. | 150 | | 900 | mV | 1 |
| Input Swing – DIF_IN | V_{SWING} | Differential value. | 300 | | | mV | 1 |
| Input Slew Rate – DIF_IN | dv/dt | Measured differentially. | 0.4 | | 8 | V/ns | 1,2 |
| Input Leakage Current | I_{IN} | $V_{IN} = V_{DD}$, $V_{IN} = GND$. | -5 | | 5 | μA | |
| Input Duty Cycle | d_{tin} | Measurement from differential waveform. | 45 | | 55 | % | 1 |
| Input Jitter – Cycle to Cycle | J_{DIFin} | Differential measurement. | 0 | | 125 | ps | 1 |

¹ Guaranteed by design and characterization, not 100% tested in production.

² Slew rate measured through $\pm 75mV$ window centered around differential zero.

Table 5. Input/Supply/Common Parameters

T_{AMB} = over the specified operating range. Supply voltages per normal operation conditions; see Test Loads for loading conditions.

| Parameter | Symbol | Conditions | Minimum | Typical | Maximum | Units | Notes |
|-------------------------------|------------|--|-----------|-------------|----------------|-------------|-------|
| Supply Voltage | V_{DDx} | Supply voltage for core and analog. | 3.135 | 3.3 | 3.465 | V | |
| Output Supply Voltage | V_{DDIO} | Supply voltage for DIF outputs, if present. | 0.95 | 1.05 | 3.465 | V | |
| Ambient Operating Temperature | T_{AMB} | Industrial range (T_{IND}). | -40 | | 85 | $^{\circ}C$ | |
| Input High Voltage | V_{IH} | Single-ended inputs, except SMBus, tri-level inputs. | 2 | | $V_{DD} + 0.3$ | V | |
| Input Low Voltage | V_{IL} | Single-ended inputs, except SMBus, tri-level inputs. | GND - 0.3 | | 0.8 | V | |
| Input High Voltage | V_{IH} | Tri-level inputs (pins with 'tri' suffix). | 2.2 | | $V_{DD} + 0.3$ | V | |
| Input Mid Voltage | V_{IL} | Tri-level inputs (pins with 'tri' suffix). | 1.2 | $V_{DDx}/2$ | 1.8 | V | |
| Input Low Voltage | V_{IL} | Tri-level inputs (pins with 'tri' suffix). | GND - 0.3 | | 0.8 | V | |
| Input Current | I_{IN} | Single-ended inputs, $V_{IN} = GND$, $V_{IN} = V_{DD}$. | -5 | | 5 | μA | |
| | I_{INP} | Single-ended inputs. $V_{IN} = 0V$; inputs with internal pull-up resistors. $V_{IN} = V_{DD}$; inputs with internal pull-down resistors. | -50 | | 50 | μA | |
| Input Frequency | F_{ibyp} | Bypass Mode. | 1 | | 400 | MHz | |
| | F_{ipll} | 100MHz PLL Mode. | 98 | 100.00 | 102 | MHz | |
| | F_{ipll} | 133.33MHz PLL Mode. | 130 | 133.33 | 136 | MHz | |
| Pin Inductance | L_{pin} | | | | 7 | nH | 1 |

Table 5. Input/Supply/Common Parameters (Cont.)

 T_{AMB} = over the specified operating range. Supply voltages per normal operation conditions; see Test Loads for loading conditions.

| Parameter | Symbol | Conditions | Minimum | Typical | Maximum | Units | Notes |
|------------------------------------|-----------------|--|---------|---------|---------|---------|-------|
| Capacitance | C_{IN} | Logic inputs, except DIF_IN. | 1.5 | | 5 | pF | 1 |
| | C_{INDIF_IN} | DIF_IN differential clock inputs. | 1.5 | | 2.7 | pF | 1,4 |
| | C_{OUT} | Output pin capacitance. | | | 6 | pF | 1 |
| Clk Stabilization | T_{STAB} | From V_{DD} power-up and after input clock stabilization or deassertion of PD# to 1st clock. | | | 1.8 | ms | 1,2 |
| Input SS Modulation Frequency PCIe | $f_{MODINPCIe}$ | Allowable frequency for PCIe applications (Triangular modulation). | 30 | | 33 | kHz | |
| Tdrive_PD# | t_{DRVPD} | DIF output enable after PD# deassertion. | | | 300 | μ s | 1,3 |
| Tfall | t_F | Fall time of control inputs. | | | 5 | ns | 2 |
| Trise | t_R | Rise time of control inputs. | | | 5 | ns | 2 |

¹ Guaranteed by design and characterization, not 100% tested in production.

² Control input must be monotonic from 20% to 80% of input swing.

³ Time from deassertion until outputs are > 200mV.

⁴ DIF_IN input.

Table 6. Current Consumption

| Parameter | Symbol | Conditions | Minimum | Typical | Maximum | Units | Notes |
|--------------------------|-------------|---|---------|---------|---------|-------|-------|
| Operating Supply Current | I_{DDA+R} | $V_{DDA} + V_{DDR}$ pins, all outputs at 100MHz, $C_L = 2pF$; $Z_o = 85\Omega$. | | 54 | 65 | mA | |
| | I_{DDO} | V_{DDIO} pins, all outputs at 100MHz, $C_L = 2pF$; $Z_o = 85\Omega$. | | 77 | 92 | mA | |
| | I_{DDx} | All other V_{DD} pins, all outputs at 100MHz, $C_L = 2pF$; $Z_o = 85\Omega$. | | 27 | 34 | mA | |
| Power Down Current | I_{DDA+R} | $V_{DDA} + V_{DDR}$ pins, all outputs Low/Low. | | 4 | 5 | mA | |
| | I_{DDO} | V_{DDIO} pins, all outputs Low/Low. | | 0.04 | 0.1 | mA | |
| | I_{DDx} | All other V_{DD} pins, all outputs Low/Low. | | 0.46 | 0.6 | mA | |

Table 7. Skew and Differential Jitter Parameters

 T_{AMB} = over the specified operating range. Supply voltages per normal operation conditions; see Test Loads for loading conditions.

| Parameter | Symbol | Conditions | Minimum | Typical | Maximum | Units | Notes |
|------------------------|-----------------|--|---------|---------|---------|----------|-----------|
| CLK_IN, DIF[x:0] | t_{SPO_PLL} | Input-to-output skew in PLL Mode at 100MHz, nominal temperature and voltage. | -100 | 22 | 100 | ps | 1,2,4,5,8 |
| CLK_IN, DIF[x:0] | t_{PD_BYP} | Input-to-output skew in Bypass Mode at 100MHz, nominal temperature and voltage. | 2.2 | 2.9 | 3.5 | ns | 1,2,3,5,8 |
| CLK_IN, DIF[x:0] | t_{DSPO_PLL} | Input-to-output skew variation in PLL Mode at 100MHz, across voltage and temperature. | -50 | 0 | 50 | ps | 1,2,3,5,8 |
| CLK_IN, DIF[x:0] | t_{DSPO_BYP} | Input-to-output skew variation in Bypass Mode at 100MHz, across voltage and temperature. | -250 | | 250 | ps | 1,2,3,5,8 |
| | | Input-to-output skew variation in Bypass Mode at 100MHz, across voltage and temperature, $T_{AMB} = T_{IND}$. | -350 | | 350 | ps | 1,2,3,5,8 |
| CLK_IN, DIF[x:0] | t_{DTE} | Random differential tracking error between two 9ZX devices in High BW Mode. | | | 5 | ps (rms) | 1,2,3,5,8 |
| CLK_IN, DIF[x:0] | t_{DSSTE} | Random differential spread spectrum tracking error between two 9ZX devices in High BW Mode. | | | 40 | ps | 1,2,3,5,8 |
| DIF[x:0] | t_{SKEW_ALL} | Output-to-output skew across all outputs, common to PLL and Bypass Mode, at 100MHz. | | 36 | 50 | ps | 1,2,3,8 |
| PLL Jitter Peaking | $j_{peak-hibw}$ | LOBW#_BYPASS_HIBW = 1. | 0 | 1 | 2.5 | dB | 7,8 |
| PLL Jitter Peaking | $j_{peak-lobw}$ | LOBW#_BYPASS_HIBW = 0. | 0 | 1 | 2 | dB | 7,8 |
| PLL Bandwidth | p_{llHIBW} | LOBW#_BYPASS_HIBW = 1. | 2 | 3 | 4 | MHz | 8,9 |
| PLL Bandwidth | p_{llLOBW} | LOBW#_BYPASS_HIBW = 0. | 0.7 | 1 | 1.4 | MHz | 8,9 |
| Duty Cycle | t_{DC} | Measured differentially, PLL Mode. | 45 | 50 | 55 | % | 1 |
| Duty Cycle Distortion | t_{DCD} | Measured differentially, Bypass Mode at 100MHz. | -1 | 0 | 1 | % | 1,10 |
| Jitter, Cycle to Cycle | $t_{jyc-cyc}$ | PLL Mode. | | 20 | 50 | ps | 1,11 |
| | | Additive jitter in Bypass Mode. | | 3 | 10 | ps | 1,11 |

¹ Measured into fixed 2pF load cap. Input to output skew is measured at the first output edge following the corresponding input.

² Measured from differential cross-point to differential cross-point. This parameter can be tuned with external feedback path, if present.

³ All Bypass Mode input-to-output specs refer to the timing between an input edge and the specific output edge created by it.

⁴ This parameter is deterministic for a given device.

⁵ Measured with scope averaging on to find mean value.

⁶ "t" is the period of the input clock.

⁷ Measured as maximum pass band gain. At frequencies within the loop BW, highest point of magnification is called PLL jitter peaking.

⁸ Guaranteed by design and characterization, not 100% tested in production.

⁹ Measured at 3db down or half power point.

¹⁰ Duty cycle distortion is the difference in duty cycle between the output and the input clock when the device is operated in Bypass Mode.

¹¹ Measured from differential waveform.

Table 8. HCSSLP-HCSSL Outputs

T_{AMB} = over the specified operating range. Supply voltages per normal operation conditions; see Test Loads for loading conditions.

| Parameter | Symbol | Conditions | Minimum | Typical | Maximum | Specification Limits | Units | Notes |
|------------------------|------------------|--|---------|---------|---------|----------------------|-------|-------|
| Slew Rate | dV/dt | Scope averaging on. | 2 | 2.6 | 4 | 1–4 | V/ns | 1,2,3 |
| Slew Rate Matching | Δ dV/dt | Single-ended measurement. | | 7 | 19.7 | 20 | % | 1,4,7 |
| Maximum Voltage | Vmax | Measurement on single-ended signal using absolute value (scope averaging off). | 660 | 815 | 888 | 1150 | mV | 7 |
| Minimum Voltage | Vmin | | -117 | -50 | | -300 | | 7 |
| Crossing Voltage (abs) | Vcross_abs | Scope averaging off. | 250 | 399 | 550 | 250–550 | mV | 1,5,7 |
| Crossing Voltage (var) | Δ -Vcross | Scope averaging off. | | 24 | 63 | 140 | mV | 1,6,7 |

¹ Guaranteed by design and characterization, not 100% tested in production.

² Measured from differential waveform.

³ Slew rate is measured through the Vswing voltage range centered around differential 0V. This results in a \pm 150mV window around differential 0V.

⁴ Matching applies to rising edge rate for Clock and falling edge rate for Clock#. It is measured using a \pm 75mV window centered on the average cross point where Clock rising meets Clock# falling. The median cross point is used to calculate the voltage thresholds the oscilloscope is to use for the edge rate calculations.

⁵ Vcross is defined as voltage where Clock = Clock# measured on a component test board and only applies to the differential rising edge (i.e. Clock rising and Clock# falling).

⁶ The total variation of all Vcross measurements in any particular system. Note that this is a subset of Vcross_min/max (Vcross absolute) allowed. The intent is to limit Vcross induced modulation by setting Δ -Vcross to be smaller than Vcross absolute.

⁷ At default SMBus settings.

Table 9. Filtered Phase Jitter Parameters - PCIe Common Clocked (CC) Architectures

| Parameter | Symbol | Conditions | Minimum | Typical | Maximum | Specification Limits | Units | Notes |
|------------------------------------|--------------------|--|---------|---------|---------|----------------------|----------|---------|
| Phase Jitter, PLL Mode | $t_{jphPCIeG1-CC}$ | PCIe Gen1. | | 13 | 34 | 86 | ps (p-p) | 1,2,3 |
| | $t_{jphPCIeG2-CC}$ | PCIe Gen2 Low Band 10kHz < f < 1.5MHz (PLL BW of 5–16MHz or 8–16MHz, CDR = 5MHz). | | 0.2 | 0.63 | 3 | ps (rms) | 1,2 |
| | | PCIe Gen2 High Band 1.5MHz < f < Nyquist (50MHz) (PLL BW of 5–16MHz or 8–16MHz, CDR = 5MHz). | | 1.0 | 1.47 | 3.1 | ps (rms) | 1,2 |
| | $t_{jphPCIeG3-CC}$ | PCIe Gen3 (PLL BW of 2–4MHz or 2–5MHz, CDR = 10MHz). | | 0.2 | 0.34 | 1 | ps (rms) | 1,2 |
| | $t_{jphPCIeG4-CC}$ | PCIe Gen4 (PLL BW of 2–4MHz or 2–5MHz, CDR = 10MHz). | | 0.2 | 0.34 | 0.5 | ps (rms) | 1,2 |
| Additive Phase Jitter, Bypass Mode | $t_{jphPCIeG1-CC}$ | PCIe Gen1. | | 0.01 | 0.052 | Not Applicable | ps (p-p) | 1,2,3,4 |
| | $t_{jphPCIeG2-CC}$ | PCIe Gen2 Low Band 10kHz < f < 1.5MHz (PLL BW of 5–16MHz or 8–16MHz, CDR = 5MHz). | | 0.01 | 0.052 | | ps (rms) | 1,2,3,4 |
| | | PCIe Gen2 High Band 1.5MHz < f < Nyquist (50MHz) (PLL BW of 5–16MHz or 8–16MHz, CDR = 5MHz). | | 0.0 | 0.052 | | ps (rms) | 1,2,3,4 |
| | $t_{jphPCIeG3-CC}$ | PCIe Gen3 (PLL BW of 2–4MHz or 2–5MHz, CDR = 10MHz). | | 0.01 | 0.052 | | ps (rms) | 1,2,3,4 |
| | $t_{jphPCIeG4-CC}$ | PCIe Gen4 (PLL BW of 2–4MHz or 2–5MHz, CDR = 10MHz). | | 0.01 | 0.052 | | ps (rms) | 1,2,3,4 |

Table 10. Filtered Phase Jitter Parameters – PCIe Independent Reference (IR) Architectures

| Parameter | Symbol | Conditions | Minimum | Typical | Maximum | Specification Limit | Units | Notes |
|------------------------------------|----------------------|---|---------|---------|---------|---------------------|----------|---------|
| Phase Jitter, PLL Mode | $t_{jphPCIeG2-SRIS}$ | PCIe Gen2 (PLL BW of 16MHz, CDR = 5MHz). | | 0.9 | 1.05 | 2 | ps (rms) | 1,2,5 |
| | $t_{jphPCIeG3-SRIS}$ | PCIe Gen3 (PLL BW of 2–4MHz, CDR = 10MHz). | | 0.6 | 0.68 | 0.7 | ps (rms) | 1,2,5 |
| Additive Phase Jitter, Bypass Mode | $t_{jphPCIeG2-SRIS}$ | PCIe Gen2 (PLL BW of 16MHz, CDR = 5MHz). | | 0.01 | 0.042 | Not applicable | ps (rms) | 1,2,4,5 |
| | $t_{jphPCIeG3-SRIS}$ | PCIe Gen3 (PLL BW of 2–4MHz, CDR = 10MHz). | | 0.01 | 0.042 | | ps (rms) | 1,2,4,5 |

Notes for PCIe Filtered Phase Jitter tables (CC) and (IR).

- ¹ Applies to all differential outputs, guaranteed by design and characterization.
- ² Calculated from Intel™-supplied clock jitter tool when driven by 9SQL495x or equivalent with spread on and off.
- ³ Sample size of at least 100K cycles. This figure extrapolates to 108ps pk-pk at 1M cycles for a BER of 1^{-12} .
- ⁴ For RMS values, additive jitter is calculated by solving for b [$b = \sqrt{c^2 - a^2}$] where “a” is rms input jitter and “c” is rms total jitter.
- ⁵ IR is the new name for Separate Reference Independent Spread (SRIS) and Separate Reference no Spread (SRNS) PCIe clock architectures. According to the PCIe Base Specification Rev4.0 version 0.7 draft, the jitter transfer functions and corresponding jitter limits are not defined for the IR clock architecture. Widely accepted industry limits using widely accepted industry filters are used to populate this table. There are no accepted filters or limits for IR clock architectures at PCIe Gen1 or Gen4 data rates.

Table 11. Filtered Phase Jitter Parameters – QPI/UPI

| Parameter | Symbol | Conditions | Minimum | Typical | Maximum | Specification Limit | Units | Notes |
|------------------------------------|-------------------|---|---------|-------------|-------------|---------------------|----------|-------|
| Phase Jitter, PLL Mode | t_{jphQPI_UPI} | QPI & UPI (100MHz or 133MHz, 4.8Gb/s, 6.4Gb/s 12UI). | | 0.14 | 0.25 | 0.5 | ps (rms) | 1,2 |
| | | QPI & UPI (100MHz, 8.0Gb/s, 12UI). | | 0.07 | 0.09 | 0.3 | | 1,2 |
| | | QPI & UPI (100MHz, ≥ 9.6 Gb/s, 12UI). | | 0.06 | 0.074 | 0.2 | | 1,2 |
| | t_{jphIF_UPI} | IF-UPI. | | 0.1 0.17 | 0.14 0.2 | 1 | | 1,4,5 |
| Additive Phase Jitter, Bypass Mode | t_{jphQPI_UPI} | QPI & UPI (100MHz or 133MHz, 4.8Gb/s, 6.4Gb/s 12UI). | | 0.00 | 0.01 | Not applicable | ps (rms) | 1,2,3 |
| | | QPI & UPI (100MHz, 8.0Gb/s, 12UI). | | 0.00 | 0.01 | | | 1,2,3 |
| | | QPI & UPI (100MHz, ≥ 9.6 Gb/s, 12UI). | | 0.00 | 0.01 | | | 1,2,3 |
| | t_{jphIF_UPI} | IF-UPI. | | 0.06 | 0.07 | | | 1,4 |

- ¹ Applies to all differential outputs, guaranteed by design and characterization.
- ² Calculated from Intel-supplied clock jitter tool, when driven by 9SQL495x or equivalent with spread on and off.
- ³ For RMS values, additive jitter is calculated by solving for b [$b = \sqrt{c^2 - a^2}$] where “a” is rms input jitter and “c” is rms total jitter.
- ⁴ Calculated from phase noise analyzer when driven by Wenzel Associates source with Intel-specified brick-wall filter applied.
- ⁵ Top number is when the buffer is in Low BW mode; bottom number is when the buffer is in High BW mode.

Table 12. Filtered Phase Jitter Parameters - DB2000Q Filter

| Parameter | Symbol | Conditions | Minimum | Typical | Maximum | Specification Limit | Units | Notes |
|-----------------------|---------------------|------------|---------|---------|---------|---------------------|----------|-------|
| Additive Phase Jitter | $t_{jph12k-20Madd}$ | 100MHz | | 50 | | 80 | fs (rms) | 1,2 |

¹ Applies to all outputs when driven by Wenzel Associates source.

² For RMS values, additive jitter is calculated by solving for b [$b = \sqrt{c^2 - a^2}$] where "a" is rms input jitter and "c" is rms total jitter.

Table 13. Unfiltered Phase Jitter Parameters – 12kHz to 20MHz

| Parameter | Symbol | Conditions | Minimum | Typical | Maximum | Specification Limit | Units | Notes |
|------------------------------------|---------------------|------------------------------|---------|---------|---------|---------------------|----------|-------|
| Phase Jitter, PLL Mode | $t_{jph12k-20MHi}$ | PLL High BW, SSC Off, 100MHz | | 194 | 233 | Not applicable | fs (rms) | 1,2 |
| Phase Jitter, PLL Mode | $t_{jph12k-20MLo}$ | PLL Low BW, SSC Off, 100MHz | | 212 | 248 | | fs (rms) | 1,2 |
| Additive Phase Jitter, Bypass Mode | $t_{jph12k-20MByp}$ | Bypass Mode, SSC Off, 100MHz | | 105 | 124 | | fs (rms) | 1,2,3 |

¹ Applies to all outputs when driven by Wenzel Associates source.

² 12kHz to 20MHz brick wall filter.

³ For RMS values, additive jitter is calculated by solving for b [$b = \sqrt{c^2 - a^2}$] where "a" is rms input jitter and "c" is rms total jitter.

Clock Periods

Table 14. Clock Periods – Differential Outputs with Spread Spectrum Disabled

| SSC On | Center Frequency MHz | Measurement Window | | | | | | | Units | Notes |
|--------|----------------------|---------------------------|---------------------------------|--------------------------------|----------------------|--------------------------------|---------------------------------|---------------------------|-------|-------|
| | | 1 Clock | 1 μ s | 0.1s | 0.1s | 0.1s | 1 μ s | 1 Clock | | |
| | | -c2cjitter AbsPer Minimum | -SSC Short-Term Average Minimum | -ppm Long-Term Average Minimum | 0 ppm Period Nominal | +ppm Long-Term Average Maximum | +SSC Short-Term Average Maximum | +c2cjitter AbsPer Maximum | | |
| DIF | 100.00 | 9.94900 | — | 9.99900 | 10.00000 | 10.00100 | — | 10.05100 | ns | 1,2,3 |
| | 133.33 | 7.44925 | — | 7.49925 | 7.50000 | 7.50075 | — | 7.55075 | ns | 1,2,4 |

Table 15. Clock Periods – Differential Outputs with Spread Spectrum Enabled

| SSC On | Center Frequency MHz | Measurement Window | | | | | | | Units | Notes |
|--------|----------------------|---------------------------|---------------------------------|--------------------------------|----------------------|--------------------------------|---------------------------------|---------------------------|-------|-------|
| | | 1 Clock | 1 μ s | 0.1s | 0.1s | 0.1s | 1 μ s | 1 Clock | | |
| | | -c2cjitter AbsPer Minimum | -SSC Short-Term Average Minimum | -ppm Long-Term Average Minimum | 0 ppm Period Nominal | +ppm Long-Term Average Maximum | +SSC Short-Term Average Maximum | +c2cjitter AbsPer Maximum | | |
| DIF | 99.75 | 9.94906 | 9.99906 | 10.02406 | 10.02506 | 10.02607 | 10.05107 | 10.10107 | ns | 1,2,3 |
| | 133.00 | 7.44930 | 7.49930 | 7.51805 | 7.51880 | 7.51955 | 7.53830 | 7.58830 | ns | 1,2,4 |

¹ Guaranteed by design and characterization, not 100% tested in production.

² All Long Term Accuracy specifications are guaranteed with the assumption that the input clock complies with CK420BQ accuracy requirements (± 100 ppm). The buffer itself does not contribute to ppm error.

³ Driven by SRC output of main clock, 100MHz PLL Mode or Bypass Mode.

⁴ Driven by CPU output of main clock, 133MHz PLL Mode or Bypass Mode.

Power Management

| Inputs | | Control Bits | Outputs | | PLL State |
|-------------|----------------|--------------|------------|--------------------|-----------|
| CKPWRGD_PD# | DIF_IN/DIF_IN# | SMBus EN bit | DIFx/DIFx# | FBOUT_NC/FBOUT_NC# | |
| 0 | X | X | Low/Low | Low/Low | Off |
| 1 | Running | 0 | Low/Low | Running | On |
| | | 1 | Running | Running | On |

Power Connections

| Pin Number | | | Description |
|-----------------|------------------------|--|--------------|
| V _{DD} | V _{DDIO} | GND | |
| 1 | | 2 | Analog PLL |
| 7 | | 6 | Analog input |
| 26, 41, 58 | 19, 31, 36, 48, 51, 63 | 16, 20, 25, 32, 35, 42, 47, 52, 57, 64 | DIF clocks |

Functionality at Power-Up (PLL Mode)

| 100M_133M# | Input (MHz) | Output (MHz) |
|------------|-------------|--------------|
| 1 | 100.00 | 100.00 |
| 0 | 133.33 | 133.33 |

PLL Operating Mode

| HIBW_BYPM_LOBW# | Byte 0, bit [7:6] |
|--------------------|-------------------|
| Low (PLL Low BW) | 00 |
| Mid (Bypass) | 01 |
| High (PLL High BW) | 11 |

SMBus Addressing

| SADR[1:0]_tri | SMBus Address (Read/Write bit = 0) |
|---------------|------------------------------------|
| 00 | D8 |
| 0M | DA |
| 01 | DE |
| M0 | C2 |
| MM | C4 |
| M1 | C6 |
| 10 | CA |
| 1M | CC |
| 11 | CE |

Test Loads

Low-Power HCSL Output Test Load
(standard PCIe source-terminated test load)

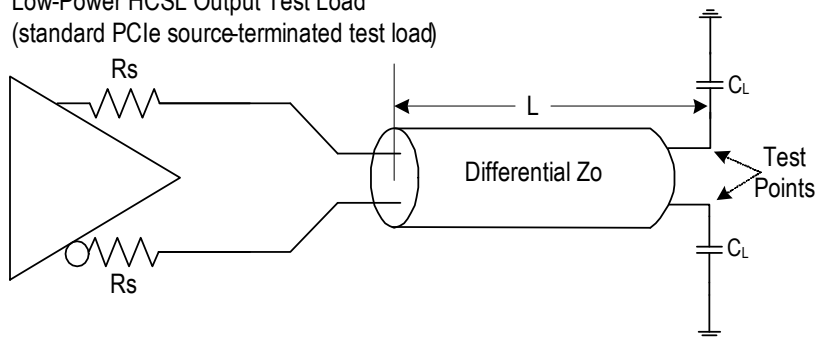

Table 16. Parameters for Low-Power HCSL Output Test Load

| Device | Rs (Ω) | Zo (Ω) | L (inches) | CL (pF) |
|-----------|-----------------|-----------------|------------|---------|
| 9ZXL1530 | 27 | 85 | 10 | 2 |
| | 33 | 100 | 10 | 2 |
| 9ZXL1550* | Internal | 85 | 10 | 2 |
| | 7.5 | 100 | 10 | 2 |

* Contact factory for versions of this device with Zo = 100 Ω .

Alternate Terminations

The LP-HCSL output can easily drive other logic families. See [“AN-891 Driving LVPECL, LVDS, and CML Logic with IDT’s “Universal” Low-Power HCSL Outputs”](#) for termination schemes for LVPECL, LVDS, CML and SSTL.

General SMBus Serial Interface Information

How to Write

- Controller (host) sends a start bit
- Controller (host) sends the write address
- IDT clock will **acknowledge**
- Controller (host) sends the beginning byte location = N
- IDT clock will **acknowledge**
- Controller (host) sends the byte count = X
- IDT clock will **acknowledge**
- Controller (host) starts sending **Byte N–Byte N+X-1**
- IDT clock will **acknowledge** each byte **one at a time**
- Controller (host) sends a stop bit

| Index Block Write Operation | | | | |
|-----------------------------|-----------|--------|----------------------|-----|
| Controller (Host) | | X Byte | IDT (Slave/Receiver) | |
| T | starT bit | | | |
| Slave Address | | | | |
| WR | WRite | | | |
| | | | | ACK |
| Beginning Byte = N | | | | |
| | | | | ACK |
| Data Byte Count = X | | | | |
| | | | | ACK |
| Beginning Byte N | | | | |
| | | | | ACK |
| O | | | | O |
| O | | | | O |
| O | | | O | |
| Byte N + X - 1 | | | | |
| | | | ACK | |
| P | stoP bit | | | |

How to Read

- Controller (host) will send a start bit
- Controller (host) sends the write address
- IDT clock will **acknowledge**
- Controller (host) sends the beginning byte location = N
- IDT clock will **acknowledge**
- Controller (host) will send a separate start bit
- Controller (host) sends the read address
- IDT clock will **acknowledge**
- IDT clock will send the data byte count = X
- IDT clock sends **Byte N+X-1**
- IDT clock sends **Byte 0–Byte X (if X_(H) was written to Byte 8)**
- Controller (host) will need to acknowledge each byte
- Controller (host) will send a not acknowledge bit
- Controller (host) will send a stop bit

| Index Block Read Operation | | | | |
|----------------------------|--------------|--------|----------------------|---------------------|
| Controller (Host) | | X Byte | IDT (Slave/Receiver) | |
| T | starT bit | | | |
| Slave Address | | | | |
| WR | WRite | | | |
| | | | | ACK |
| Beginning Byte = N | | | | |
| | | | | ACK |
| RT | Repeat starT | | | |
| Slave Address | | | | |
| RD | ReaD | | | |
| | | | | ACK |
| | | | | Data Byte Count = X |
| ACK | | | | |
| ACK | | | Beginning Byte N | |
| | | | O | |
| O | | | O | |
| O | | | O | |
| O | | | | |
| | | | Byte N + X - 1 | |
| N | Not | | | |
| P | stoP bit | | | |

SMBus Table: PLL Mode and Frequency Select Register

| Byte 0 | Pin # | Name | Control Function | Type | 0 | 1 | Default |
|--------|----------|------------|-------------------------------|------|-------------------------------------|--------|---------|
| Bit 7 | — | PLL Mode 1 | PLL Operating Mode Readback 1 | R | See <i>PLL Operating Mode</i> table | | Latch |
| Bit 6 | — | PLL Mode 0 | PLL Operating Mode Readback 0 | R | | | Latch |
| Bit 5 | Reserved | | | | | | 0 |
| Bit 4 | — | DIF_14_En | Output Control | RW | Disable (Low/Low) | Enable | 1 |
| Bit 3 | — | DIF_13_En | Output Control | RW | | | 1 |
| Bit 2 | Reserved | | | | | | 0 |
| Bit 1 | Reserved | | | | | | 0 |
| Bit 0 | — | 100M_133M# | Frequency Select Readback | R | 133MHz | 100MHz | Latch |

SMBus Table: Output Control Register

| Byte 1 | Pin # | Name | Control Function | Type | 0 | 1 | Default |
|--------|----------|----------|------------------|------|----------------------|--------|---------|
| Bit 7 | — | DIF_5_En | Output Enable | RW | Disable (Low/Low) | Enable | 1 |
| Bit 6 | Reserved | | | | | | 0 |
| Bit 5 | — | DIF_4_En | Output Enable | RW | Disable (Low/Low) | Enable | 1 |
| Bit 4 | — | DIF_3_En | Output Enable | RW | | | 1 |
| Bit 3 | — | DIF_2_En | Output Enable | RW | | | 1 |
| Bit 2 | — | DIF_1_En | Output Enable | RW | | | 1 |
| Bit 1 | — | DIF_0_En | Output Enable | RW | | | 1 |
| Bit 0 | Reserved | | | | | | 0 |

SMBus Table: Output Control Register

| Byte 2 | Pin # | Name | Control Function | Type | 0 | 1 | Default |
|--------|----------|-----------|------------------|------|----------------------|--------|---------|
| Bit 7 | — | DIF_12_En | Output Control | RW | Disable (Low/Low) | Enable | 1 |
| Bit 6 | — | DIF_11_En | Output Control | RW | | | 1 |
| Bit 5 | — | DIF_10_En | Output Control | RW | | | 1 |
| Bit 4 | Reserved | | | | | | 0 |
| Bit 3 | — | DIF_9_En | Output Enable | RW | Disable (Low/Low) | Enable | 1 |
| Bit 2 | — | DIF_8_En | Output Enable | RW | | | 1 |
| Bit 1 | — | DIF_7_En | Output Enable | RW | | | 1 |
| Bit 0 | — | DIF_6_En | Output Enable | RW | | | 1 |

SMBus Table: Reserved Register

| Byte 3 | Pin # | Name | Control Function | Type | 0 | 1 | Default |
|--------|----------|------------|--|------|-------------------------------------|---------------|---------|
| Bit 7 | — | amp[2] | Global Differential Output Control (LP-HCSL Outputs Only) | RW | 0.3V–1V 100mV/step Default = 0.8V | | 1 |
| Bit 6 | — | amp[1] | | RW | | | 0 |
| Bit 5 | — | amp[0] | | RW | | | 1 |
| Bit 4 | Reserved | | | | | | 0 |
| Bit 3 | — | PLL_SW_EN | Enable S/W Control of PLL BW | RW | Hardware Latch | SMBus Control | 0 |
| Bit 2 | — | PLL Mode 1 | PLL Operating Mode 1 | RW | See <i>PLL Operating Mode</i> table | | Latch |
| Bit 1 | — | PLL Mode 0 | PLL Operating Mode 1 | RW | | | Latch |
| Bit 0 | Reserved | | | | | | 0 |

Note: Setting bit 3 to '1' allows the user to override the latch value from pin 4 via use of bits 2 and 1. Use the values from the *PLL Operating Mode* table. Note that Byte 0, bits 7 and 6 will keep the value originally latched on pin 4. If the user changes these bits, a warm reset of the system will have to be accomplished.

SMBus Table: Reserved Register

| Byte 4 | Pin # | Name | Control Function | Type | 0 | 1 | Default |
|--------|----------|------|------------------|------|---|---|---------|
| Bit 7 | Reserved | | | | | | 0 |
| Bit 6 | Reserved | | | | | | 0 |
| Bit 5 | Reserved | | | | | | 0 |
| Bit 4 | Reserved | | | | | | 0 |
| Bit 3 | Reserved | | | | | | 0 |
| Bit 2 | Reserved | | | | | | 0 |
| Bit 1 | Reserved | | | | | | 0 |
| Bit 0 | Reserved | | | | | | 0 |

SMBus Table: Vendor & Revision ID Register

| Byte 5 | Pin # | Name | Control Function | Type | 0 | 1 | Default |
|--------|-------|------|------------------|------|----------------|---|---------|
| Bit 7 | — | RID3 | REVISION ID | R | D = 0011 | | 0 |
| Bit 6 | — | RID2 | | R | | | 0 |
| Bit 5 | — | RID1 | | R | | | 1 |
| Bit 4 | — | RID0 | | R | | | 1 |
| Bit 3 | — | VID3 | VENDOR ID | R | ICS/IDT = 0001 | | 0 |
| Bit 2 | — | VID2 | | R | | | 0 |
| Bit 1 | — | VID1 | | R | | | 0 |
| Bit 0 | — | VID0 | | R | | | 1 |

SMBus Table: Device ID

| Byte 6 | Pin # | Name | Control Function | Type | 0 | 1 | Default |
|--------|-------|-------------------|------------------|------|------------------------------------|---|---------|
| Bit 7 | — | Device ID 7 (MSB) | | R | 1530/1550 is 155 Decimal or 9B Hex | | 1 |
| Bit 6 | — | Device ID 6 | | R | | x | |
| Bit 5 | — | Device ID 5 | | R | | 0 | |
| Bit 4 | — | Device ID 4 | | R | | x | |
| Bit 3 | — | Device ID 3 | | R | | x | |
| Bit 2 | — | Device ID 2 | | R | | 0 | |
| Bit 1 | — | Device ID 1 | | R | | 1 | |
| Bit 0 | — | Device ID 0 | | R | | 1 | |

SMBus Table: Byte Count Register

| Byte 7 | Pin # | Name | Control Function | Type | 0 | 1 | Default |
|--------|----------|------|---|------|---|---|---------|
| Bit 7 | Reserved | | | | | | 0 |
| Bit 6 | Reserved | | | | | | 0 |
| Bit 5 | Reserved | | | | | | 0 |
| Bit 4 | — | BC4 | Writing to this register configures how many bytes will be read back. | RW | Default value is 8 hex, so 9 bytes (0 to 8) will be read back by default. | | 0 |
| Bit 3 | — | BC3 | | RW | | 1 | |
| Bit 2 | — | BC2 | | RW | | 0 | |
| Bit 1 | — | BC1 | | RW | | 0 | |
| Bit 0 | — | BC0 | | RW | | 0 | |

Package Outline Drawings

The package outline drawings are appended at the end of this document and are also accessible from the link below. The package information is the most current data available and is subject to change without notice or revision of this document.

www.idt.com/document/psc/nlg64-package-outline-90-x-90-mm-body-050-mm-pitch-qfn-epad-size-615-x-615-mm

Ordering Information

| Orderable Part Number | Differential Output Impedance (Ω) | Package | Carrier Type | Temperature |
|-----------------------|--|----------------------------------|--------------|----------------|
| 9ZXL1530DKILF | 33 | 9 x 9 mm, 0.50mm pitch 64-VFQFPN | Trays | -40°C to +85°C |
| 9ZXL1530DKILFT | 33 | 9 x 9 mm, 0.50mm pitch 64-VFQFPN | Reel | -40°C to +85°C |
| 9ZXL1550DKILF | 85 | 9 x 9 mm, 0.50mm pitch 64-VFQFPN | Trays | -40°C to +85°C |
| 9ZXL1550DKILFT | 85 | 9 x 9 mm, 0.50mm pitch 64-VFQFPN | Reel | -40°C to +85°C |

“LF” designates PB-free configuration, RoHS compliant.

“D” is the device revision designator (will not correlate with the datasheet revision).

Marking Diagrams



1. "I" denotes industrial temperature range
2. "L" denotes RoHS compliant package.
3. "YYWW" denotes the last two digits of the year and week the part was assembled.
4. "COO" denotes country of origin.
5. "LOT" denotes the lot number.

Revision History

| Revision Date | Description of Change |
|--------------------|---|
| April 12, 2018 | Updated absolute maximum supply voltage rating and VIHSMB to 3.9V. |
| February 13, 2018 | <ul style="list-style-type: none"> ▪ Updated front page text to indicate DB2000Q compatibility. ▪ Removed reference to 5V tolerance in description of SMBDAT and SMBCLK pins. ▪ Added DB2000Q additive phase jitter table. |
| December 1, 2017 | Removed "5V tolerant" reference in pins 11 and 12 descriptions. |
| November 2, 2017 | <ul style="list-style-type: none"> ▪ Corrected PCIe, UPI phase jitter tables per characterization data. ▪ Corrected transposed values for HiBW and Bypass Mode unfiltered phase jitter. |
| September 29, 2017 | Initial release. |



Corporate Headquarters
 6024 Silver Creek Valley Road
 San Jose, CA 95138 USA
www.IDT.com

Sales
 1-800-345-7015 or 408-284-8200
 Fax: 408-284-2775
www.IDT.com/go/sales

Tech Support
www.IDT.com/go/support

DISCLAIMER Integrated Device Technology, Inc. (IDT) and its affiliated companies (herein referred to as "IDT") reserve the right to modify the products and/or specifications described herein at any time, without notice, at IDT's sole discretion. Performance specifications and operating parameters of the described products are determined in an independent state and are not guaranteed to perform the same way when installed in customer products. The information contained herein is provided without representation or warranty of any kind, whether express or implied, including, but not limited to, the suitability of IDT's products for any particular purpose, an implied warranty of merchantability, or non-infringement of the intellectual property rights of others. This document is presented only as a guide and does not convey any license under intellectual property rights of IDT or any third parties.

IDT's products are not intended for use in applications involving extreme environmental conditions or in life support systems or similar devices where the failure or malfunction of an IDT product can be reasonably expected to significantly affect the health or safety of users. Anyone using an IDT product in such a manner does so at their own risk, absent an express, written agreement by IDT.

Integrated Device Technology, IDT and the IDT logo are trademarks or registered trademarks of IDT and its subsidiaries in the United States and other countries. Other trademarks used herein are the property of IDT or their respective third party owners. For datasheet type definitions and a glossary of common terms, visit www.idt.com/go/glossary. Integrated Device Technology, Inc All rights reserved.

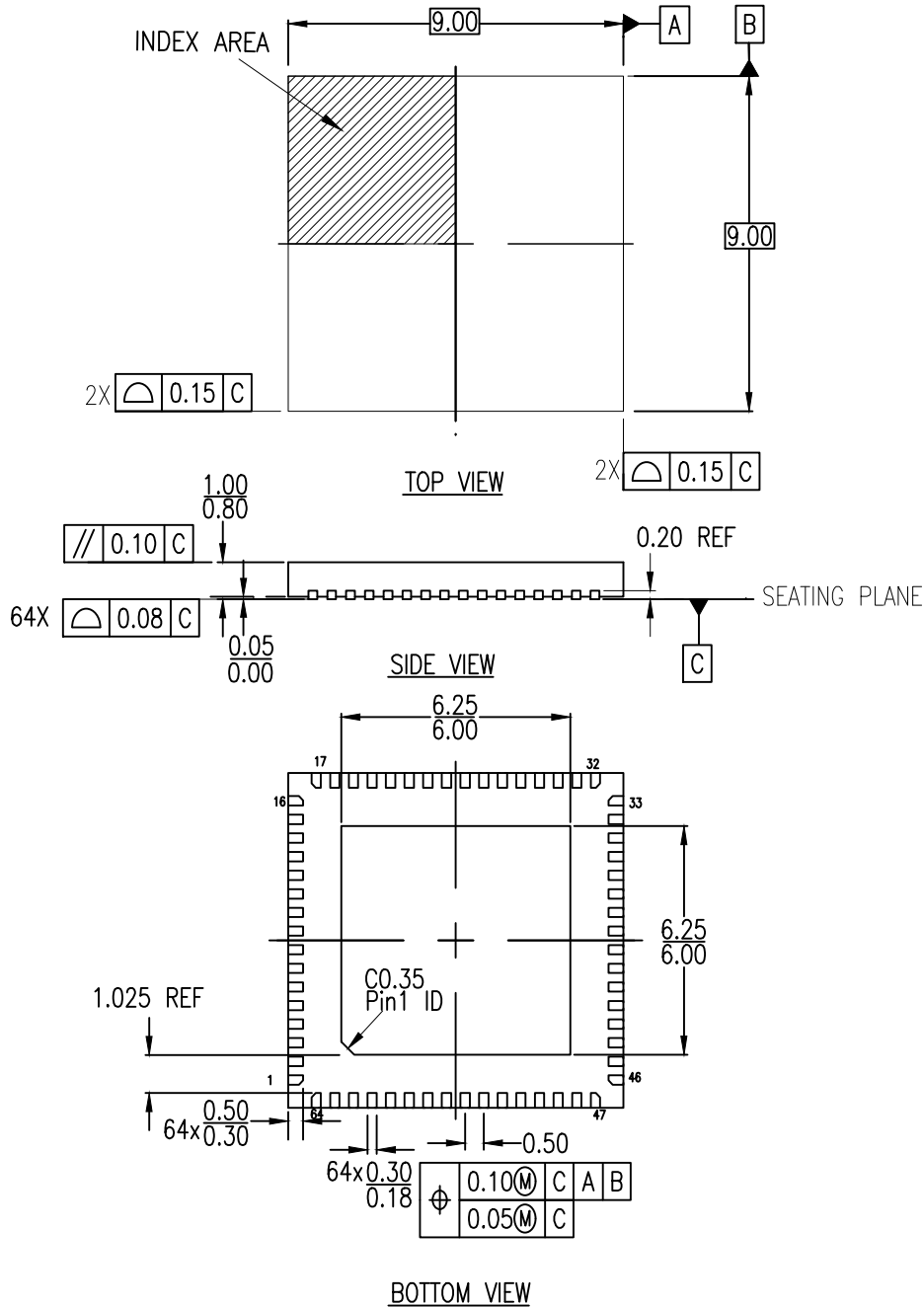

NOTES:

1. ALL DIMENSIONING AND TOLERANCEING CONFORM TO ANSI Y14.5M-1982
2. ALL DIMENSIONS ARE IN MILLIMETERS

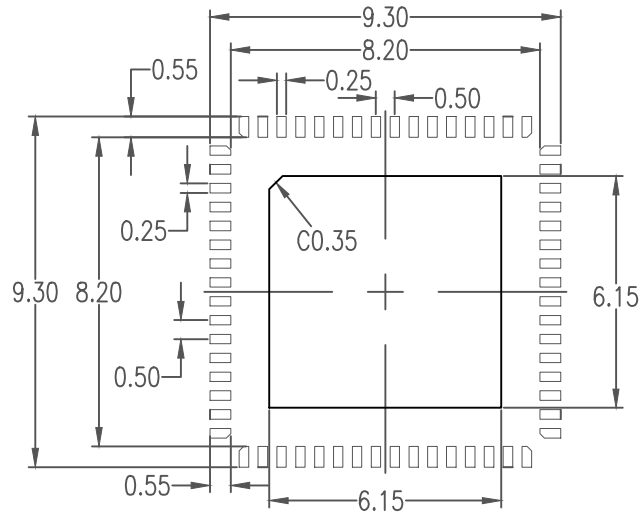

RECOMMENDED LAND PATTERN DIMENSION

NOTES:

1. ALL DIMENSIONING AND TOLERANCING CONFORM TO ANSI Y14.5M-1982
2. ALL DIMENSIONS ARE IN MILLIMETERS
3. LAND PATTERN RECOMMENDATION PER IPC-7351B GENERIC REQUIREMENT FOR SURFACE MOUNT DESIGN AND LAND PATTERN

| Package Revision History | | |
|--------------------------|---------|--|
| Date Created | Rev No. | Description |
| Feb 21, 2018 | Rev 01 | New Format, Change QFN to VFQFPN, Added P2 |
| Nov 3, 2015 | Rev 00 | Initial Release |

Компания «Life Electronics» занимается поставками электронных компонентов импортного и отечественного производства от производителей и со складов крупных дистрибьюторов Европы, Америки и Азии.

С конца 2013 года компания активно расширяет линейку поставок компонентов по направлению коаксиальный кабель, кварцевые генераторы и конденсаторы (керамические, пленочные, электролитические), за счёт заключения дистрибьюторских договоров

Мы предлагаем:

- Конкурентоспособные цены и скидки постоянным клиентам.
- Специальные условия для постоянных клиентов.
- Подбор аналогов.
- Поставку компонентов в любых объемах, удовлетворяющих вашим потребностям.
- Приемлемые сроки поставки, возможна ускоренная поставка.
- Доставку товара в любую точку России и стран СНГ.
- Комплексную поставку.
- Работу по проектам и поставку образцов.
- Формирование склада под заказчика.
- Сертификаты соответствия на поставляемую продукцию (по желанию клиента).
- Тестирование поставляемой продукции.
- Поставку компонентов, требующих военную и космическую приемку.
- Входной контроль качества.
- Наличие сертификата ISO.

В составе нашей компании организован Конструкторский отдел, призванный помогать разработчикам, и инженерам.

Конструкторский отдел помогает осуществить:

- Регистрацию проекта у производителя компонентов.
- Техническую поддержку проекта.
- Защиту от снятия компонента с производства.
- Оценку стоимости проекта по компонентам.
- Изготовление тестовой платы монтаж и пусконаладочные работы.



Тел: +7 (812) 336 43 04 (многоканальный)
Email: org@lifeelectronics.ru