

## 150 W – 50 V moisture resistant HF/VHF DMOS transistor

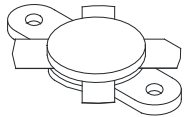

M174MR epoxy sealed

1. Drain
2. Source
3. Gate
4. Source

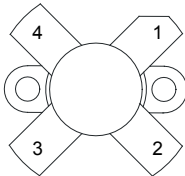

### Features

- Gold metallization
- Excellent thermal stability
- Common source push-pull configuration
- $P_{OUT} = 150\text{ W}$  min. with 14 dB gain @ 175 MHz
- Thermally enhanced packing for lower junction temperatures
- $G_{FS}$  and  $V_{GS}$  sort marked on unit
- Moisture resistant package specifically designed to operate in extreme environments

### Description

The [SD2931-12MR](#) is a gold metallized N-channel MOS field-effect RF power transistor. Electrically identical to the standard SD2931 MOSFET, it is used for 50 V DC large signal applications up to 230 MHz.

The device is mechanically compatible with the SD2931 but offers better thermal capability (25% lower thermal resistance), representing the best-in-class in transistors for ISM applications, where reliability and ruggedness are critical factors.

The [SD2931-12MR](#) benefits from the latest generation of environmentally designed packing, ruggedized against cyclic high moisture operation and severe storage conditions.

Product status	
SD2931-12MR	
Product summary	
Order code	SD2931-12MR
Marking	SD2931-11MR
Package	M174
Packing	Plastic tray

## 1 Electrical data

### 1.1 Maximum ratings

 $T_{CASE} = 25\text{ °C}$ 
**Table 1. Absolute maximum ratings**

Symbol	Parameter	Value	Unit
$V_{(BR)DSS}$	Drain source voltage	125	V
$V_{DGR}$	Drain-gate voltage ( $R_{GS} = 1\text{ M}\Omega$ )	125	V
$V_{GS}$	Gate-source voltage	$\pm 40$	V
$I_D$	Drain current	20	A
$P_{DISS}$	Power dissipation	389	W
$T_J$	Max. operating junction temperature	200	°C
$T_{STG}$	Storage temperature	-65 to +150	°C

### 1.2 Thermal data

**Table 2. Thermal data**

Symbol	Parameter	Value	Unit
$R_{thJC}$	Junction-to-case thermal resistance	0.45	°C/W

## 2 Electrical characteristics

 $T_{CASE} = 25\text{ }^{\circ}\text{C}$ 
**Table 3. Static**

Symbol	Test conditions	Min.	Typ.	Max.	Unit
$V_{(BR)DSS}$	$V_{GS} = 0\text{ V}$ $I_{DS} = 100\text{ mA}$	125			V
$I_{DSS}$	$V_{GS} = 0\text{ V}$ $V_{DS} = 5\text{ V}$			20	
	$V_{GS} = 0\text{ V}$ $V_{DS} = 50\text{ V}$			50	$\mu\text{A}$
$I_{GSS}$	$V_{GS} = 20\text{ V}$ $V_{DS} = 0\text{ V}$			250	nA
$V_{GS(Q)}^{(1)}$	$V_{DS} = 10\text{ V}$ $I_D = 250\text{ mA}$	See table below			V
$V_{DS(ON)}$	$V_{GS} = 10\text{ V}$ $I_D = 10\text{ A}$			3.0	V
$G_{FS}^{(1)}$	$V_{DS} = 10\text{ V}$ $I_D = 5\text{ A}$	See table below			mho
$C_{ISS}$	$V_{GS} = 0\text{ V}$ $V_{DS} = 50\text{ V}$ $f = 1\text{ MHz}$		480		pF
$C_{OSS}$	$V_{GS} = 0\text{ V}$ $V_{DS} = 50\text{ V}$ $f = 1\text{ MHz}$		190		pF
$C_{RSS}$	$V_{GS} = 0\text{ V}$ $V_{DS} = 50\text{ V}$ $f = 1\text{ MHz}$		18		pF

1.  $V_{GS(Q)}$  and  $G_{FS}$  sorted with alpha/numeric code marked on unit.

**Table 4.  $V_{GS}$  and  $G_{FS}$  sorts**

Code	$V_{GS}$	$G_{FS}$
I	2.65 - 3.15	6.0 - 6.5
J	2.65 - 3.15	6.5 - 7.0
K	2.65 - 3.15	7.0 - 7.5

**Table 5. Dynamic**

Symbol	Test conditions	Min.	Typ.	Max.	Unit
$P_{OUT}$	$V_{DD} = 50\text{ V}$ $I_{DQ} = 250\text{ mA}$ $f = 175\text{ MHz}$	150			W
$G_{PS}$	$V_{DD} = 50\text{ V}$ $I_{DQ} = 250\text{ mA}$ $P_{OUT} = 150\text{ W}$ $f = 175\text{ MHz}$	14	15		dB
$\eta_D$	$V_{DD} = 50\text{ V}$ $I_{DQ} = 250\text{ mA}$ $P_{OUT} = 150\text{ W}$ $f = 175\text{ MHz}$	55	65		%
Load mismatch	$V_{DD} = 50\text{ V}$ $I_{DQ} = 250\text{ mA}$ $P_{OUT} = 150\text{ W}$ $f = 175\text{ MHz}$ all phase angles	10:1			VSWR

### 3 Transient thermal impedance

Figure 3. Transient thermal impedance

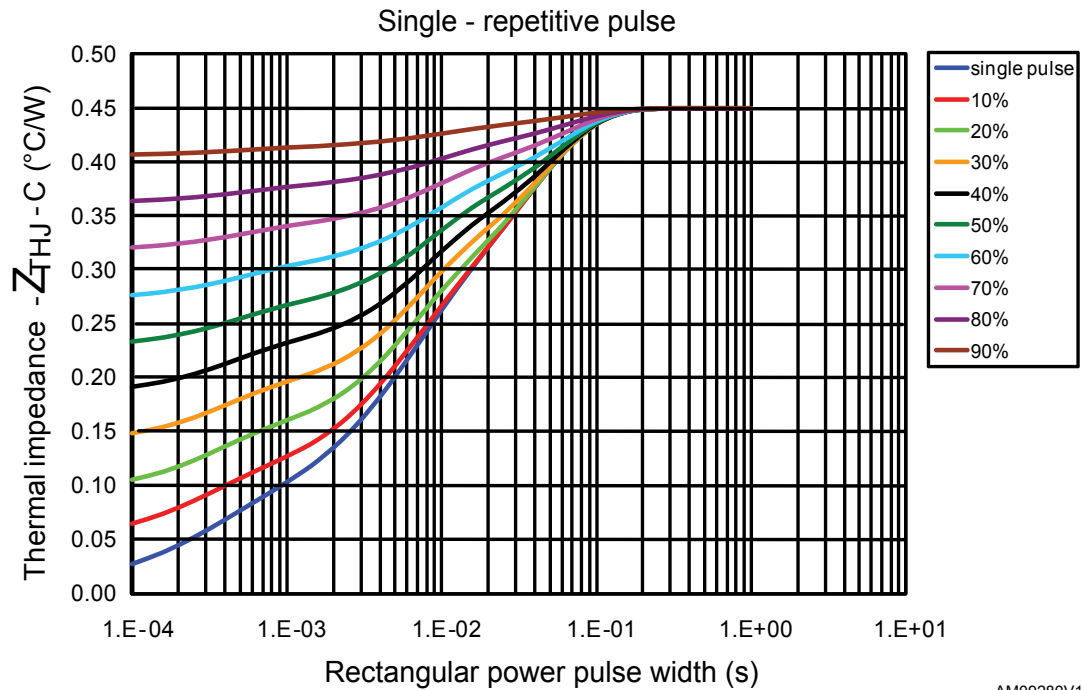
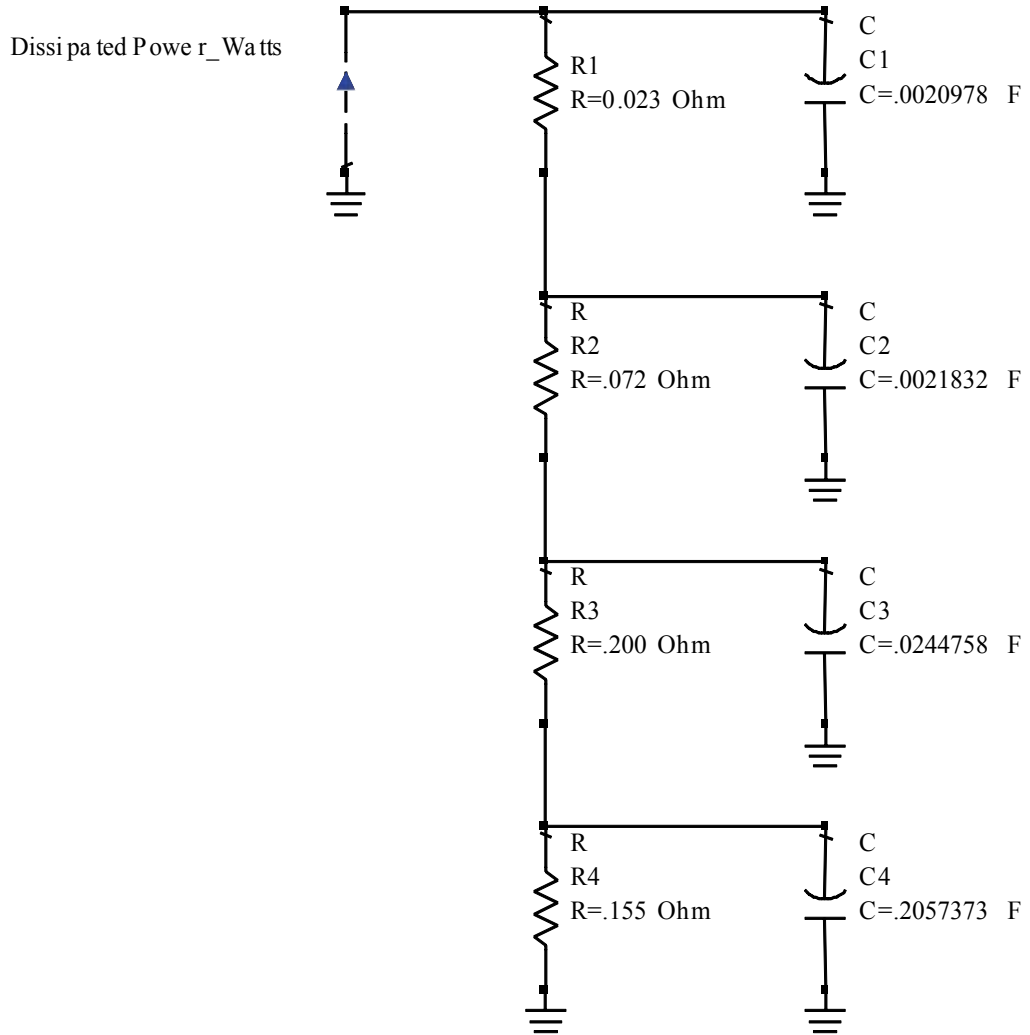
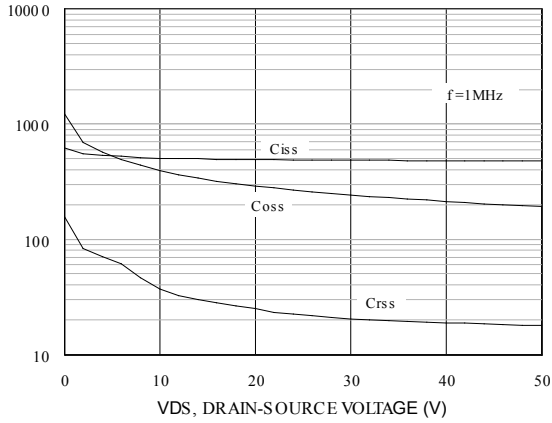
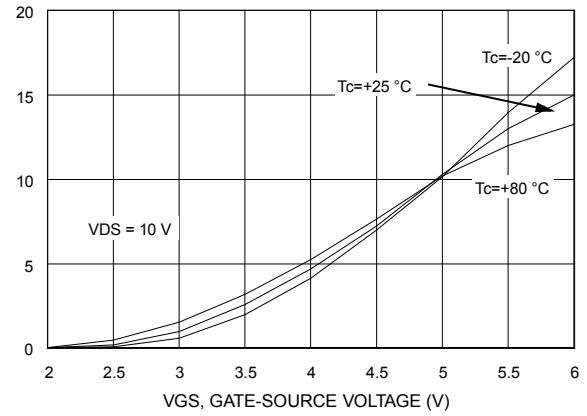
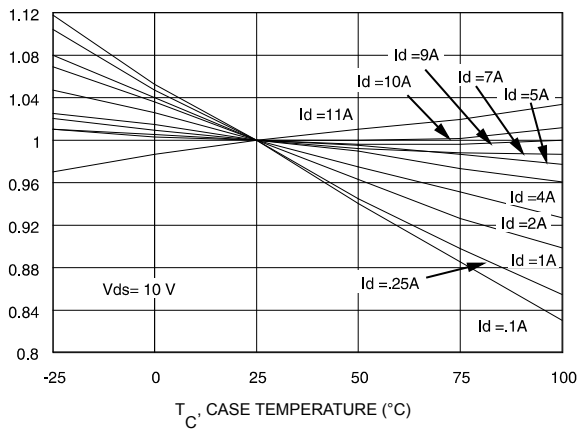
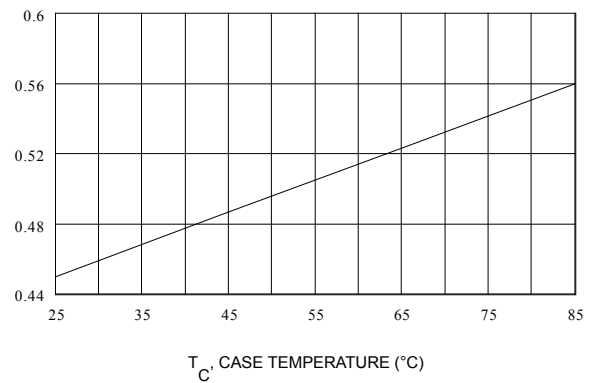
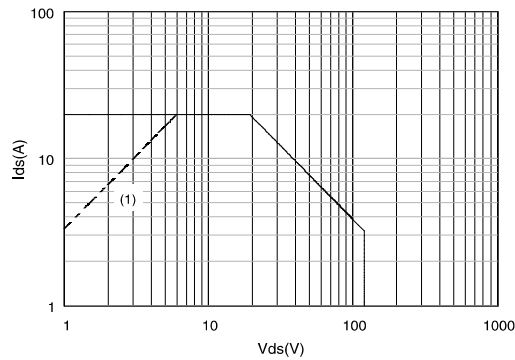

Figure 4. Transient thermal impedance model



AM09281V1

## 4 Typical performance

**Figure 5. Capacitance vs. drain voltage**

**Figure 6. Drain current vs. gate voltage**

**Figure 7. Gate-source voltage vs. case temperature**

**Figure 8. Maximum thermal resistance vs. case temperature**

**Figure 9. Safe operating area**

### 4.1 Typical performance (175 MHz)

Figure 10. Output power vs. input power

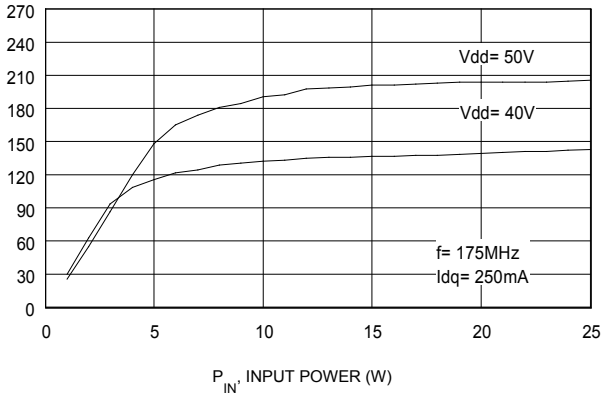

Figure 11. Output power vs. input power at different  $T_c$

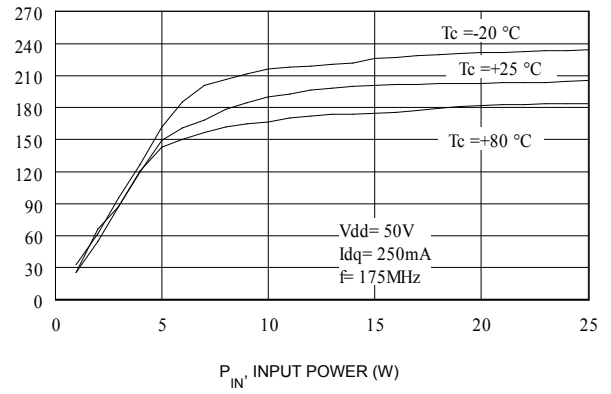

Figure 12. Power gain vs. output power

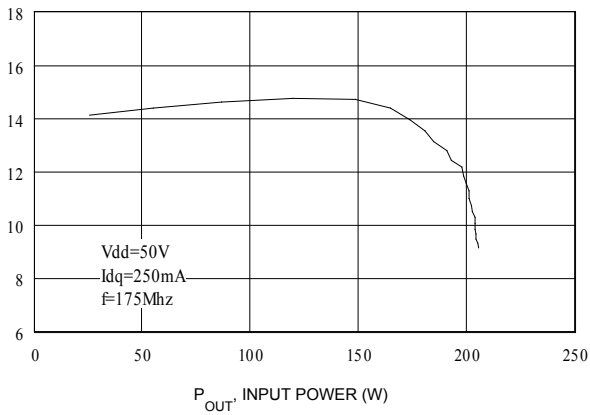

Figure 13. Efficiency vs. output power

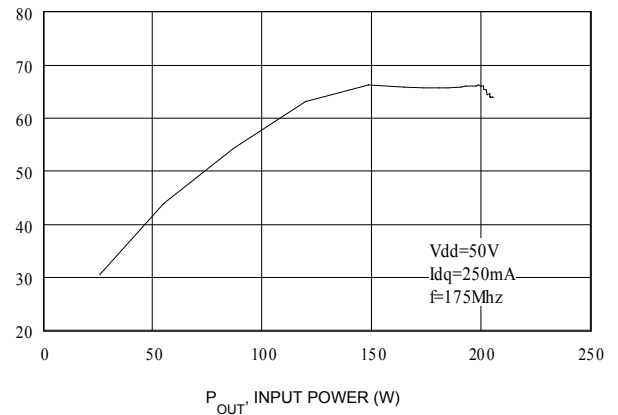

Figure 14. Output power vs. supply voltage

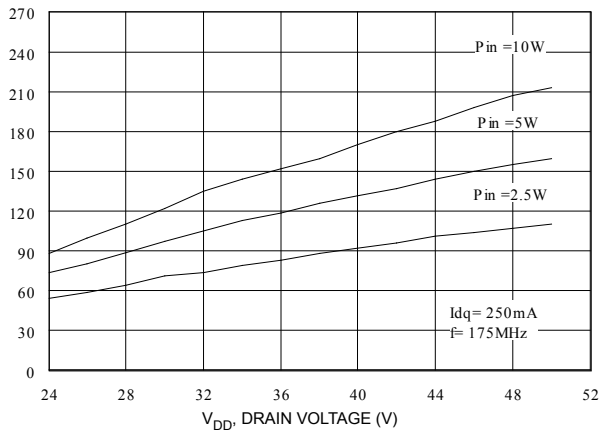
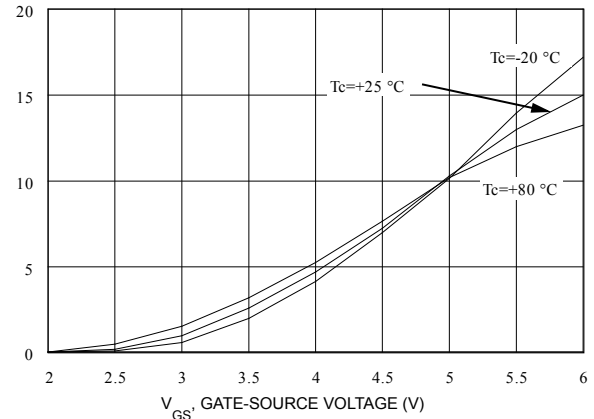

Figure 15. Drain current vs. gate-source voltage



### 4.1.1 Test circuit (175 MHz)

Figure 16. 175 MHz test circuit schematic (production test circuit)

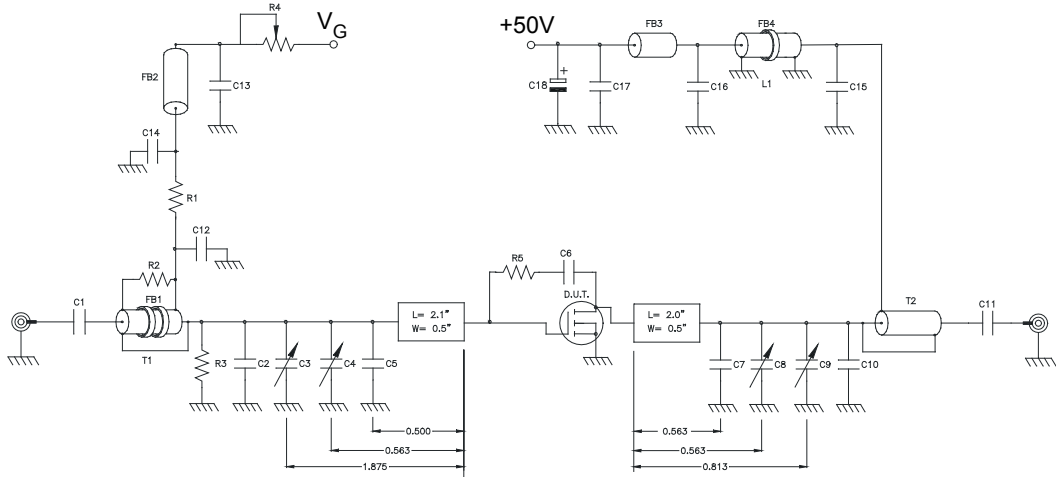
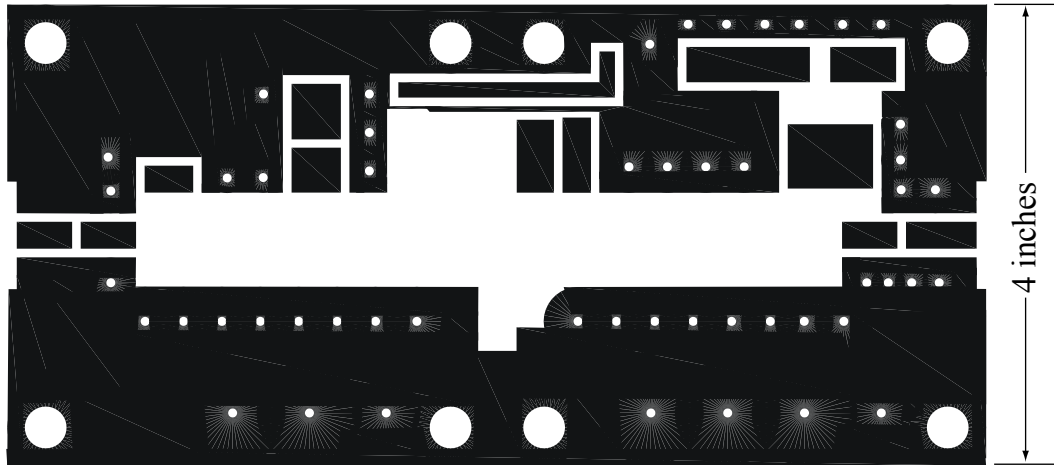

Table 6. 175 MHz test circuit part list

Component	Description
T1	4:1 transformer, 25 Ω flexible coax .090 OD 6" long
T2	1:4 transformer, 25 Ω semi-rigid coax .141 OD 6" long
FB1	Toroid X 2, 0.5" OD .312" ID 850 μ 2 turns
FB2, FB3	VK200
FB4	Shield bead, 1" OD 0.5" ID 850 μ 3 turns
L1	1/4 wave choke, 50 Ω semi-rigid coax .141 OD 12" long
PCB	0.62" woven fiberglass, 1 oz. copper, 2 sides, ε <sub>r</sub> = 2.55
R1, R3	470 Ω 1 W chip resistor
R2	360 Ω 1/2 W resistor
R4	20 kΩ 10 turn potentiometer
R5	560 Ω 1 W resistor
C1, C11	470 pF ATC chip cap
C2	43 pF ATC chip cap
C3, C8, C9	Arco 404, 12-65 pF
C4	Arco 423, 16-100 pF
C5	120 pF ATC chip cap
C6	0.01 μF ATC chip cap
C7	30 pF ATC chip cap
C10	91 pF ATC chip cap
C12, C15	1200 pF ATC chip cap
C13, C14, C16, C17	0.01 μF / 500 V chip cap
C18	10 μF 63 V electrolytic capacitor



**Figure 17. 175 MHz test circuit photomaster**



**Figure 18. 175 MHz test circuit**

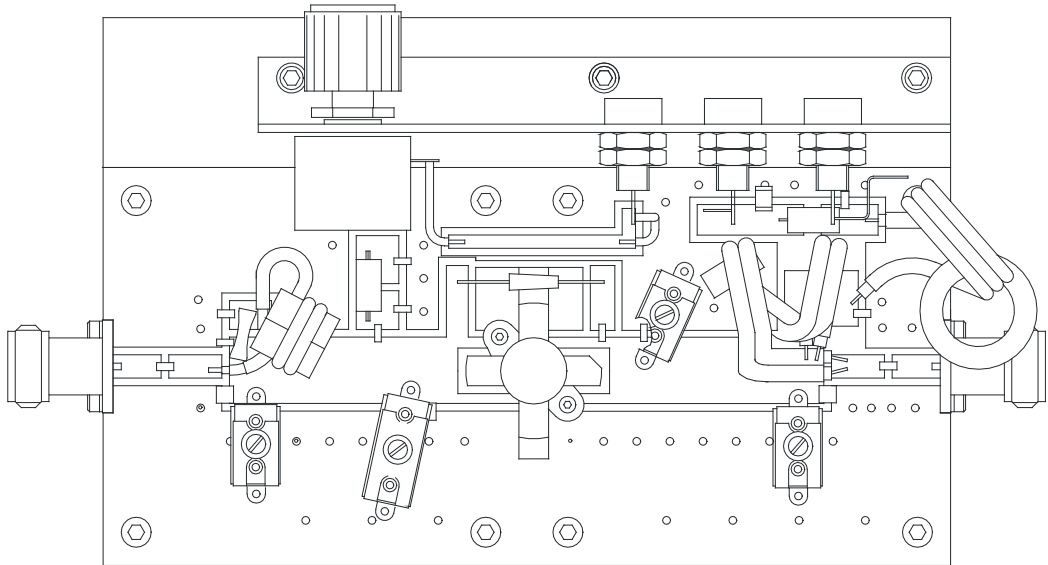

## 4.2 Typical performance (30 MHz)

Figure 19. Output power vs. input power

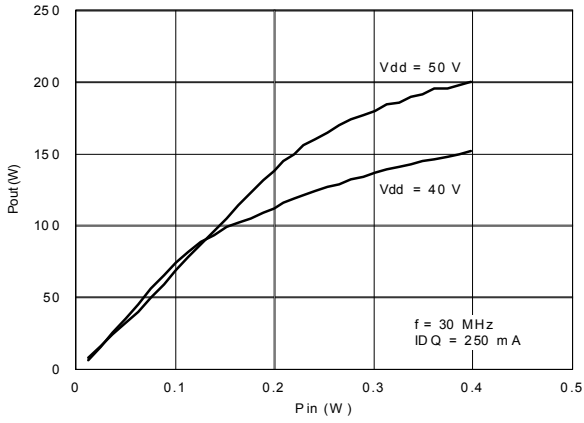

Figure 20. Power gain vs. output power

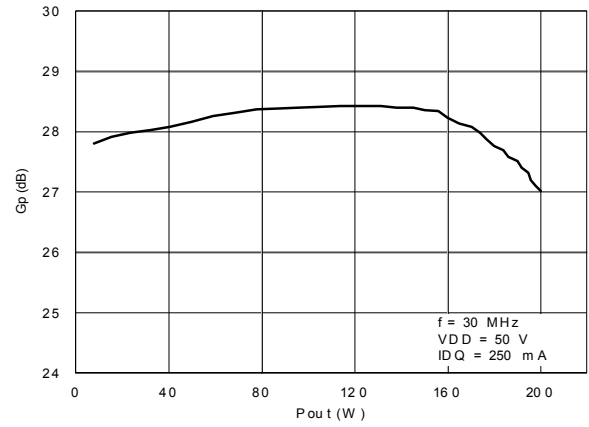

Figure 21. Efficiency vs. output power

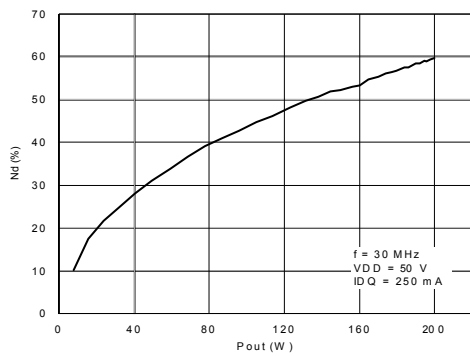

Figure 22. Output power vs. supply voltage

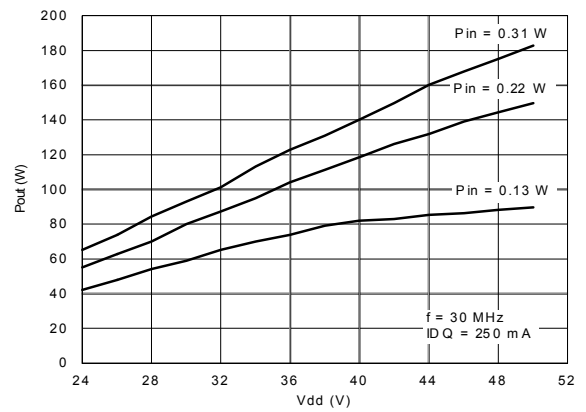
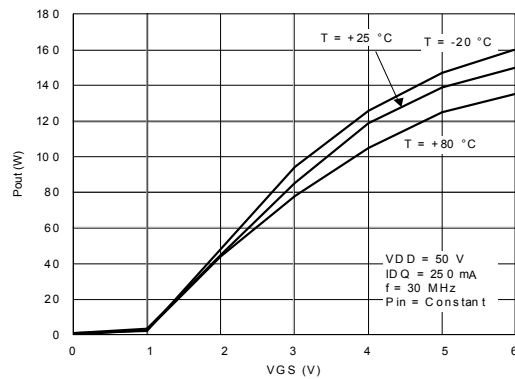
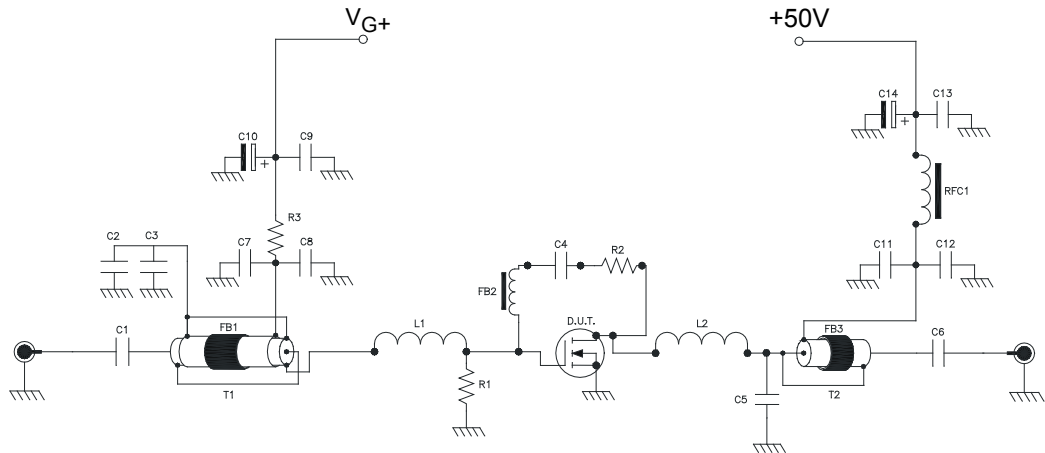

Figure 23. Output power vs. gate-source voltage



**4.2.1 Test circuit (30 MHz)**

**Figure 24. 30 MHz test circuit schematic (production test circuit)**



**Table 7. 30 MHz test circuit part list**

Component	Description
T1	9:1 transformer, 25 $\Omega$ flexible coax with extra shield .090 OD 15" long
T2	1:4 transformer, 50 $\Omega$ flexible coax .225 OD 15" long
FB1	Toroid 1.7" OD .30" ID 220 $\mu$ 4 turns
FB2	Surface mount EMI shield bead
FB3	Toroid 1.7" OD .300" ID 220 $\mu$ 3 turns
RFC1	Toroid 0.5" OD 0.30" ID 125 $\mu$ 4 turns 12 awg wire
PCB	0.62" woven fiberglass, 1 oz. copper, 2 sides, $\epsilon_r = 2.55$
R1, R3	1 kohm 1 W chip resistor
R2	680 ohm 3 W wirewound resistor
C1, C4, C6, C7, C8, C9, C11, C12, C13	0.1 $\mu$ F ATC chip cap
C2, C3	750 pF ATC chip cap
C5	470 pF ATC chip cap
C10	10 $\mu$ F 63 V electrolytic capacitor
C14	100 $\mu$ F 63 V electrolytic capacitor

## 5 Marking, packing and shipping specifications

**Table 8. Packing and shipping specifications**

Order code	Packing	Pieces per tray	Dry pack humidity	V <sub>GS</sub> and G <sub>FS</sub> code	Lot code
SD2931-12MR	Plastic tray	25	< 10%	Not mixed	Not mixed

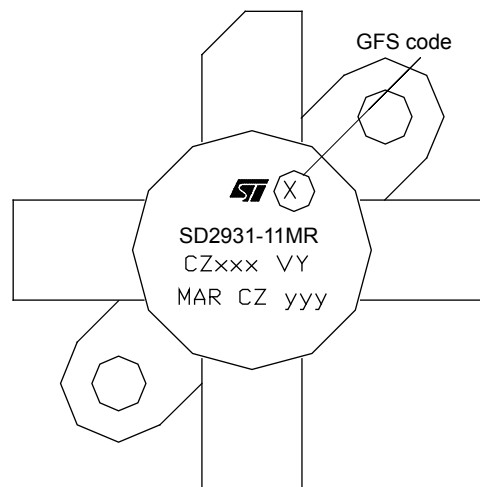
**Figure 25. SD2931-12MR marking layout**

**Table 9. Marking specifications**

Symbol	Description
X	V <sub>GS</sub> and G <sub>FS</sub> sort
CZ	Assembly plant
xxx	Last 3 digits of diffusion lot
VY	Diffusion plant
MAR	Country of origin
CZ	Test and finishing plant
y	Assembly year
yy	Assembly week

## 6 Package information

In order to meet environmental requirements, ST offers these devices in different grades of ECOPACK® packages, depending on their level of environmental compliance. ECOPACK® specifications, grade definitions and product status are available at: [www.st.com](http://www.st.com). ECOPACK® is an ST trademark.

### 6.1 M174MR package information

Figure 26. M174MR package outline

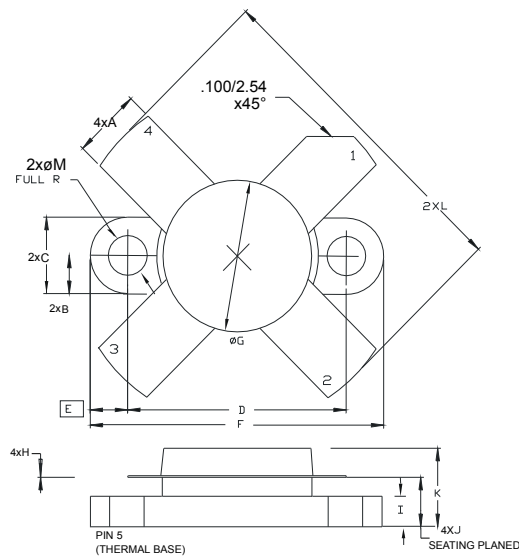

8410504 rev. A

Table 10. M174 package mechanical data

Dim.	mm		
	Min.	Typ.	Max.
A	5.56		5.584
B		3.18	
C	6.22		6.48
D	18.28		18.54
E		3.18	
F	24.64		24.89
G	12.07		12.83
H	0.08		0.18
I	2.11		3.00
J	3.81		4.45
K			8.00
L	25.53		26.67
M	3.05		3.30

## Revision history

**Table 11. Document revision history**

Date	Revision	Changes
20-Feb-2013	1	Initial release
10-Sep-2013	2	Document promoted from preliminary data to full datasheet. Formatting and minor text changes.
11-Nov-2016	3	Updated <i>Table 2: "Absolute maximum ratings"</i> .
07-Feb-2018	4	Updated marking in cover page and <a href="#">Figure 25. SD2931-12MR marking layout</a> . Minor text changes.

## Contents

<b>1</b>	<b>Electrical data</b> .....	<b>2</b>
1.1	Maximum ratings .....	2
1.2	Thermal data .....	2
<b>2</b>	<b>Electrical characteristics</b> .....	<b>3</b>
<b>3</b>	<b>Transient thermal impedance</b> .....	<b>4</b>
<b>4</b>	<b>Typical performance</b> .....	<b>6</b>
4.1	Typical performance (175 MHz) .....	6
4.1.1	Test circuit (175 MHz) .....	7
4.2	Typical performance (30 MHz) .....	9
4.2.1	Test circuit (30 MHz) .....	10
<b>5</b>	<b>Marking, packing and shipping specifications</b> .....	<b>12</b>
<b>6</b>	<b>Package information</b> .....	<b>13</b>
6.1	M174MR package information .....	13
	<b>Revision history</b> .....	<b>14</b>
	<b>Contents</b> .....	<b>15</b>
	<b>Disclaimer</b> .....	<b>16</b>

**IMPORTANT NOTICE – PLEASE READ CAREFULLY**

STMicroelectronics NV and its subsidiaries (“ST”) reserve the right to make changes, corrections, enhancements, modifications, and improvements to ST products and/or to this document at any time without notice. Purchasers should obtain the latest relevant information on ST products before placing orders. ST products are sold pursuant to ST’s terms and conditions of sale in place at the time of order acknowledgement.

Purchasers are solely responsible for the choice, selection, and use of ST products and ST assumes no liability for application assistance or the design of Purchasers’ products.

No license, express or implied, to any intellectual property right is granted by ST herein.

Resale of ST products with provisions different from the information set forth herein shall void any warranty granted by ST for such product.

ST and the ST logo are trademarks of ST. All other product or service names are the property of their respective owners.

Information in this document supersedes and replaces information previously supplied in any prior versions of this document.

© 2018 STMicroelectronics – All rights reserved



Компания «Life Electronics» занимается поставками электронных компонентов импортного и отечественного производства от производителей и со складов крупных дистрибьюторов Европы, Америки и Азии.

С конца 2013 года компания активно расширяет линейку поставок компонентов по направлению коаксиальный кабель, кварцевые генераторы и конденсаторы (керамические, пленочные, электролитические), за счёт заключения дистрибьюторских договоров

Мы предлагаем:

- Конкурентоспособные цены и скидки постоянным клиентам.
- Специальные условия для постоянных клиентов.
- Подбор аналогов.
- Поставку компонентов в любых объемах, удовлетворяющих вашим потребностям.
- Приемлемые сроки поставки, возможна ускоренная поставка.
- Доставку товара в любую точку России и стран СНГ.
- Комплексную поставку.
- Работу по проектам и поставку образцов.
- Формирование склада под заказчика.
- Сертификаты соответствия на поставляемую продукцию (по желанию клиента).
- Тестирование поставляемой продукции.
- Поставку компонентов, требующих военную и космическую приемку.
- Входной контроль качества.
- Наличие сертификата ISO.

В составе нашей компании организован Конструкторский отдел, призванный помогать разработчикам, и инженерам.

Конструкторский отдел помогает осуществить:

- Регистрацию проекта у производителя компонентов.
- Техническую поддержку проекта.
- Защиту от снятия компонента с производства.
- Оценку стоимости проекта по компонентам.
- Изготовление тестовой платы монтаж и пусконаладочные работы.



Тел: +7 (812) 336 43 04 (многоканальный)  
Email: [org@lifeelectronics.ru](mailto:org@lifeelectronics.ru)