

Ordering a market-ready enclosure® is made fast and affordable with our complete in-house capabilities. New Age provides machined openings to fit your PCB, pad printing for your graphics, custom enclosures, custom colors, final assembly, testing and fulfillment services to save you additional time and money. Ask your representative for a free quote today 805-595-1310.

Fast and Affordable Customization

**CNC Modifications
Pad Printing
Colored Resins
EMI/RF Shielding
Custom Enclosure
Assembly & Testing**

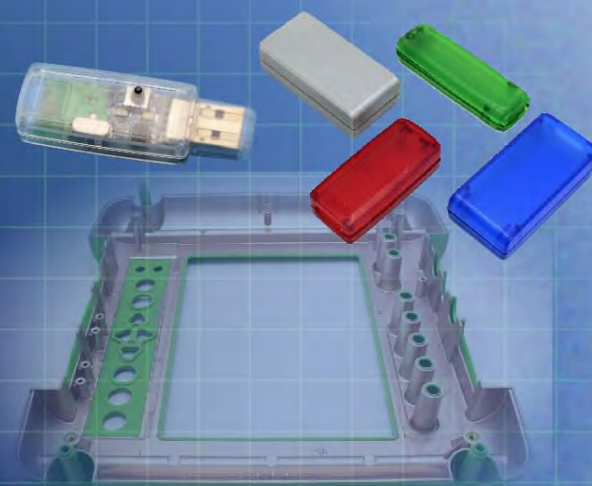

ISO quality
off-the-shelf
to market-ready®

NEW AGE ENCLOSURES

www.NewAgeEnclosures.com

4330 Santa Fe Road • San Luis Obispo, CA 93401 • T 805.595.1310 • F 805.595.1024

NOTES: UNLESS OTHERWISE SPECIFIED

1. CORNERS DRAWN SHARP TO BE R.005 MAXIMUM.
2. EXTERIOR SURFACE TEXTURE TO BE LIGHT EDM FINISH. EQUIVELANT TO MT-11010.
3. INTERIOR SURFACE TEXTURE TO BE: NONE
4. ALL INSIDE RADII .010R. ALL OUTSIDE RADII .020R MAX, UNLESS OTHERWISE SPECIFIED.
5. ALL EXTERNAL DIMENSIONS AFFECTED BY THE DRAFT APPLY AT THE LARGE END OF THE FEATURE, AND ALL INTERNAL FEATURES AFFECTED BY THE DRAFT APPLY AT THE SMALL END OF THE FEATURE UNLESS OTHERWISE SPECIFIED.
6. 1 DEGREE DRAFT IN THE DIRECTION OF PULL IS PERMISSIBLE UNLESS OTHERWISE SPECIFIED.
7. MATERIAL / COLOR: ABS PLASTIC IS STANDARD IN BLACK OR WHITE. CUSTOM MATERIALS AND COLORS ARE AVAILABLE UPON REQUEST FOR QUOTE.
8. PCB SIZES ARE RECOMMENDATIONS ONLY. FINAL SIZES AND VERIFICATION OF IT'S FIT ARE THE SOLE RESPONSIBILITY OF EACH OWNER.
9. ASSEMBLY SCREWS FOR THE ENCLOSURE ARE PROVIDED. MOUNTING SCREWS FOR PCB AND BATTERY CONTACTS SOLD SEPERATELY.
10. THIS DRAWING IS BASED ON A SOLID MODEL, AND IS FURTHER DEFINED BY THE SOLID MODEL FILE.
11. ALLOWABLE FLASH: 0.010 MAX.
12. ALL EJECTOR PIN MARKS TO BE WITHIN 0.010" OF FLUSH, PROTRUDING OR BELOW FLUSH.

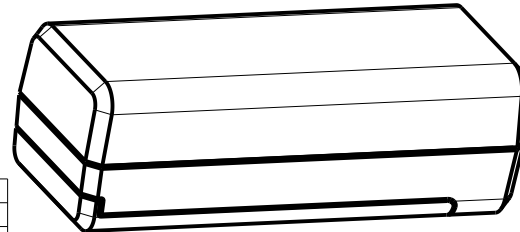

SCALE 0.900

281109(x) CONFIGURATIONS			
	-Blank	-K	-W
281109 COVER	1	1	
281109 BASE	1		
281109 BASE MODIFIED (2nd OP)		1	
281109 WALL CRADLE		1	1
281109 HATCH	1	1	
#2 HiLo SCREW .312"	4	4	

11	AAA-SINGL-CONTACT-POS	ACC-AAAPOS-5226	SPRING STEEL	SOLD SEPERATELY	1
10	AAA-SINGL-CONTACT-NEG	ACC-AAANEG-5204	SPRING STEEL	SOLD SEPERATELY	1
9	AAA-DBL-CONTACT	ACC-AAADBL-5214L	SPRING STEEL	SOLD SEPERATELY	1
8	SCREW-DRYWALLX750	DRYWALL SCREW - REFERENCE	CUSTOMER SUPPLIED	DRYWALL SCREW	2
7	281109_WALL-CRADLE	281109 WALL CRADLE - STANDARD	ABS	BLACK or WHITE	1
6	281109_HATCH	281109 HATCH - STANDARD	ABS	BLACK or WHITE	1
5	281109_COVER	281109 COVER - STANDARD	ABS	BLACK or WHITE	1
4	281109_BASE-MODIFIED	281109 BASE - MODIFIED	ABS	BLACK or WHITE	1
3	SCREW_HILO-N02X312	#2 HiLo x .312" SCREW	ZINK PLATED	5/16" LONG	4
2	281109_PCB	REFERENCE ONLY	CUSTOMER SUPPLIED	.062" THICK	1
1	AAA-BATTERY	REFERENCE ONLY	CUSTOMER SUPPLIED	"AAA" SIZE	2
ITEM	FILE NAME	DESCRIPTION	MATERIAL	COLOR	QTY.

BILL OF MATERIALS

R E V I S I O N

REV.	DRAWN BY	ECO No	DESCRIPTION	DATE	APPROVED
A-G	M BOYER		PRELIMINARY THROUGH CONCEPT - SEE REV G	14-Jun-2012	D.C.
1.0	M BOYER		RELEASED TO MFG PER CUSTOMER	27-Nov-2012	D.C.
1.1	R CRUZ	4614	UPDATE TEXTURE CALLOUT	21-Oct-2014	D.C.
2.0	M BOYER	4914	INCLUDE WALL CRADLE	01-Dec-2014	D.C.
2.1	M BOYER		INCLUDE CRADLE TEXTURE CALLOUT	03-Apr-2015	D.C.
2.2	R CRUZ	02615	UPDATE WALL CRADLE NOTCH TOLERANCE ON BASE	22-May-2015	D.C.
2.3	M BOYER	04815	REVISE ASSY SCREW LENGTH	2015-Nov-05	

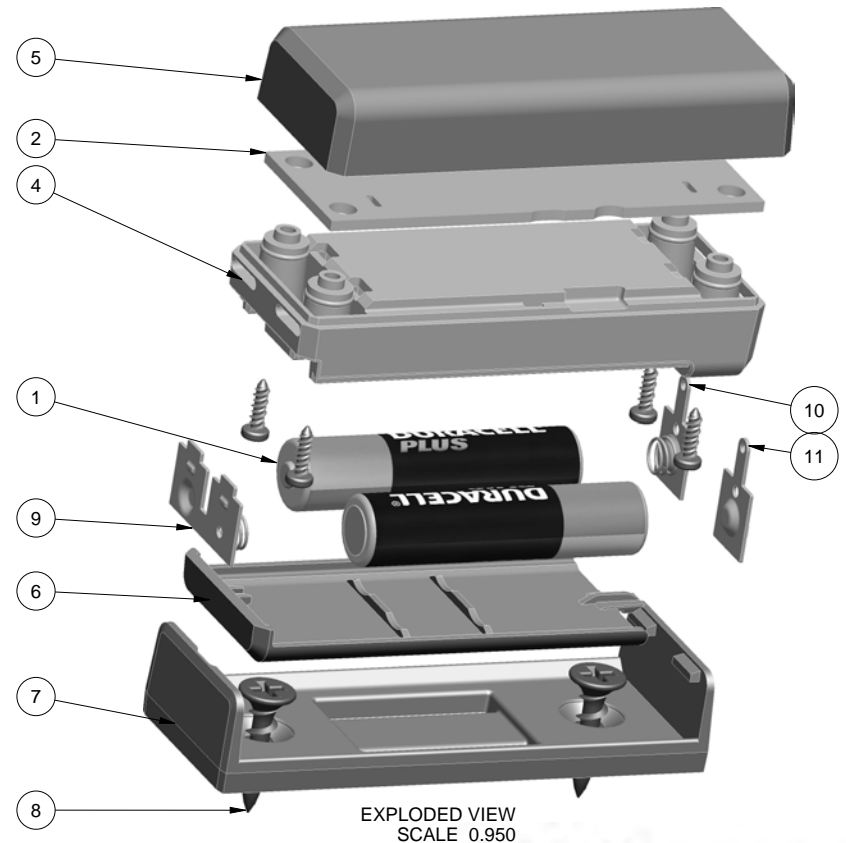

THIRD ANGLE PROJECTION
DO NOT SCALE DRAWING

TOLERANCES: UNLESS OTHERWISE SPECIFIED DIMENSIONS ARE IN U.S. INCHES.
X.XX = .015 X.XXXX = .001
X.XXX = .010 X.X" = 1°

NEW AGE ENCLOSURES
4330 Santa Fe Road San Luis Obispo, CA. 93401
ph. (805) 595-1310 fax (805) 595-1024

Customer's Part No: 281109

APPROVAL	BY	DATE
ENG.		
QUALITY		
SCALE	AS NOTED	

DRAWN BY
M BOYER 2012-Jun-15

www.newageenclosures.com

**STANDARD - COMPACT AAA
SXX-281109X-XXX**

SIZE A DRAWING NAME 281109_R2_3 SHEET 1 OF 8 REV.DOC 2.3

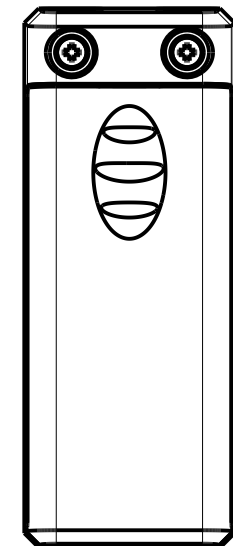
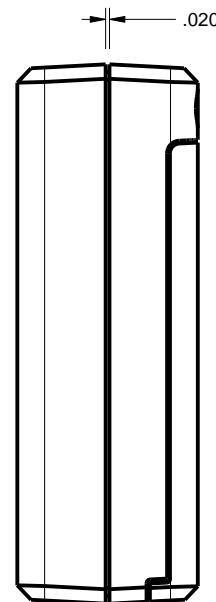
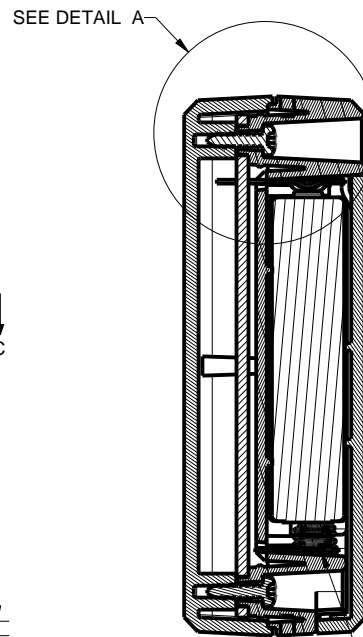
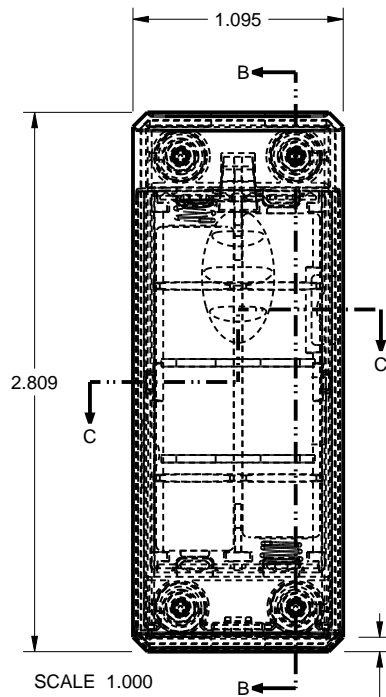
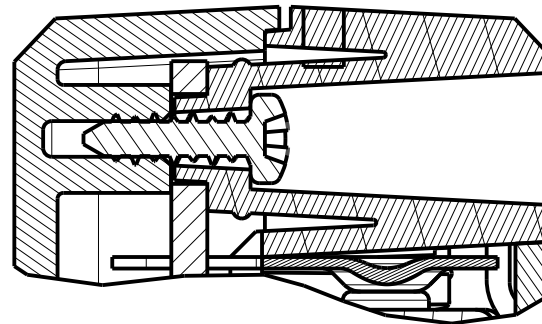
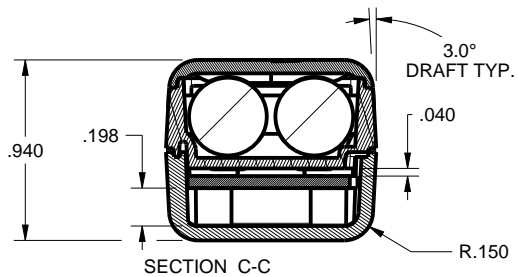

.075 x 45° CHAMFER

DOUBLE BATTERY CONTACT (BRIDGE)
SHOULD BE INSTALLED ON THIS END
OF THE ENCLOSURE.

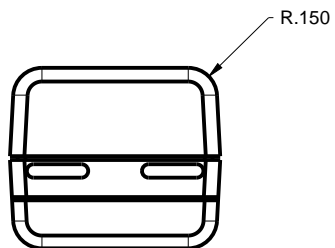

TOLERANCES: UNLESS OTHERWISE SPECIFIED
DIMENSIONS ARE IN U.S. INCHES.
X.XX = .015 X.XXXX = .001
X.XXX = .010 X.X° = 1°

Customer's Part No: 281109

APPROVAL	BY	DATE
CHECK		
ENG.		
SCALE	AS NOTED	

DRAWN BY	2012-Jun-15
M BOYER	

NEW AGE ENCLOSURES
4330 Santa Fe Road San Luis Obispo, CA. 93401
ph. (805) 595-1310 fax (805) 595-1024
www.newageenclosures.com

STANDARD - COMPACT AAA
SXX-281109X-XXX

SIZE	DRAWING NAME
A	281109_R2_3

SHEET	REV.DOC
2 OF 8	2.3

281109 COVER

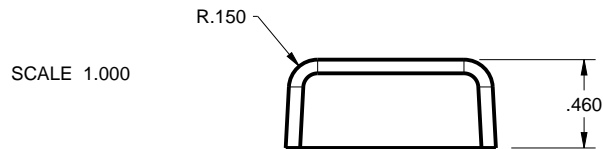
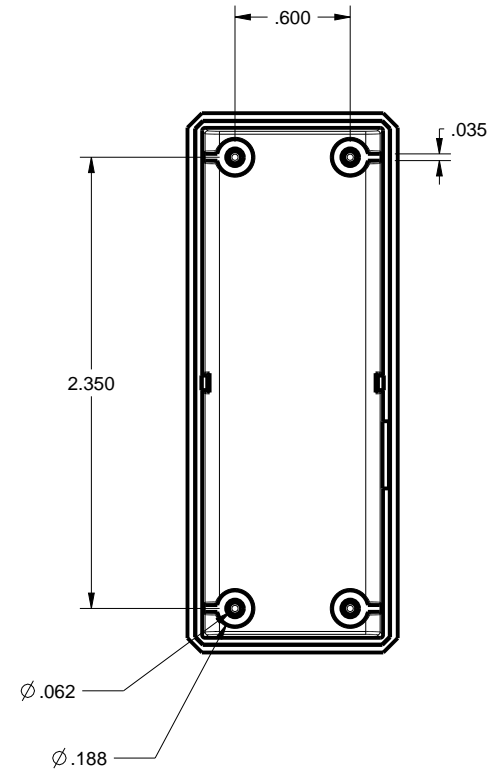
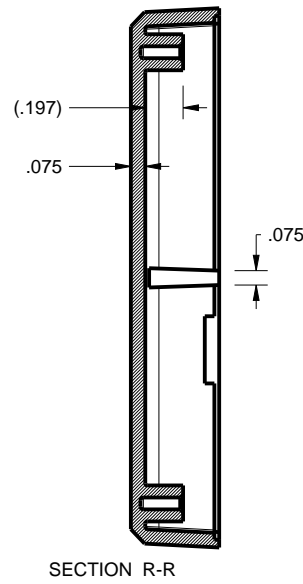
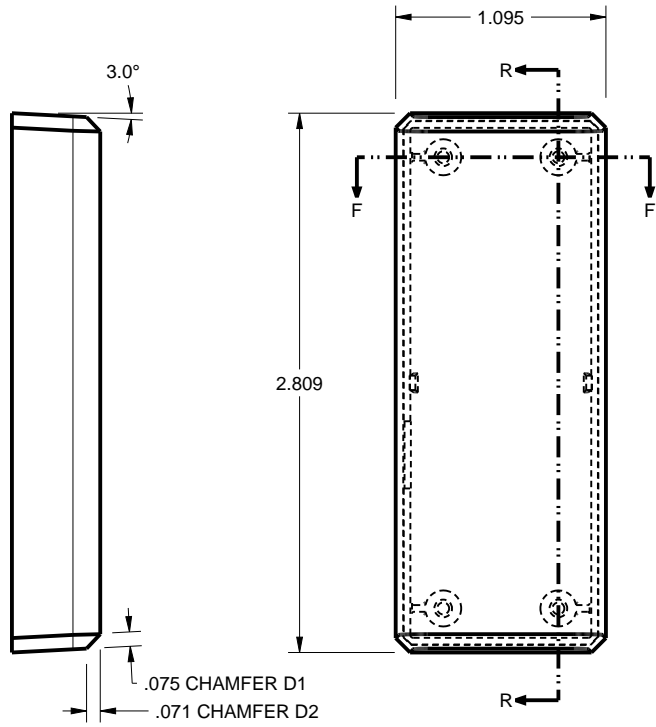
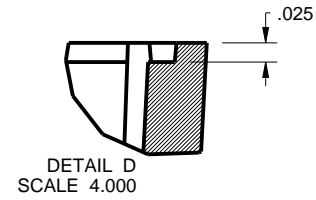
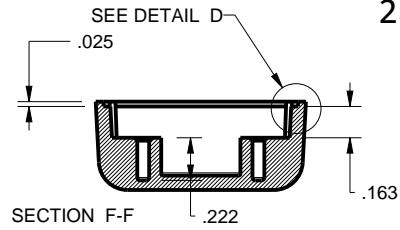

TOLERANCES: UNLESS OTHERWISE SPECIFIED DIMENSIONS ARE IN U.S. INCHES.	
X.XX = .015 X.XXXX = .001	
X.XXX = .010 X.X° = 1°	
NEW AGE ENCLOSURES	
Customer's Part No: 281109	
APPROVAL	BY DATE
CHECK	
ENG.	
SCALE	AS NOTED
DRAWN BY	2012-Jun-15
M BOYER	

NEW AGE ENCLOSURES
 4330 Santa Fe Road San Luis Obispo, CA. 93401
 ph. (805) 595-1310 fax (805) 595-1024
www.newageenclosures.com

**STANDARD - COMPACT AAA
 SXX-281109X-XXX**

SIZE	DRAWING NAME	SHEET	REV.DOC
A	281109_R2_3	3 OF 8	2.3

281109 BASE

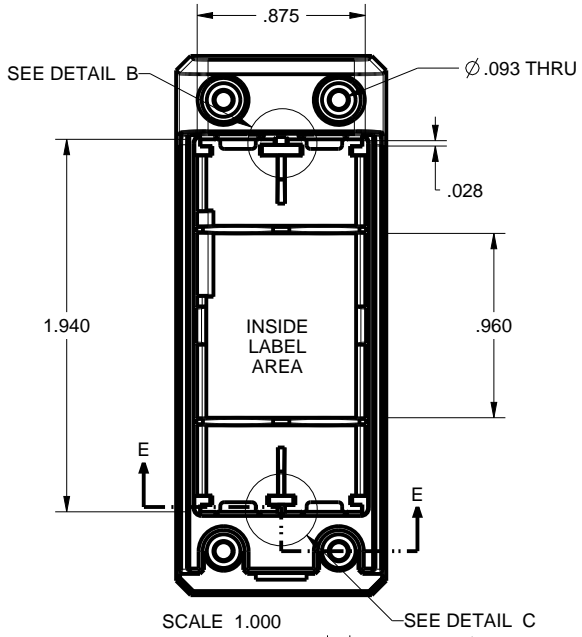
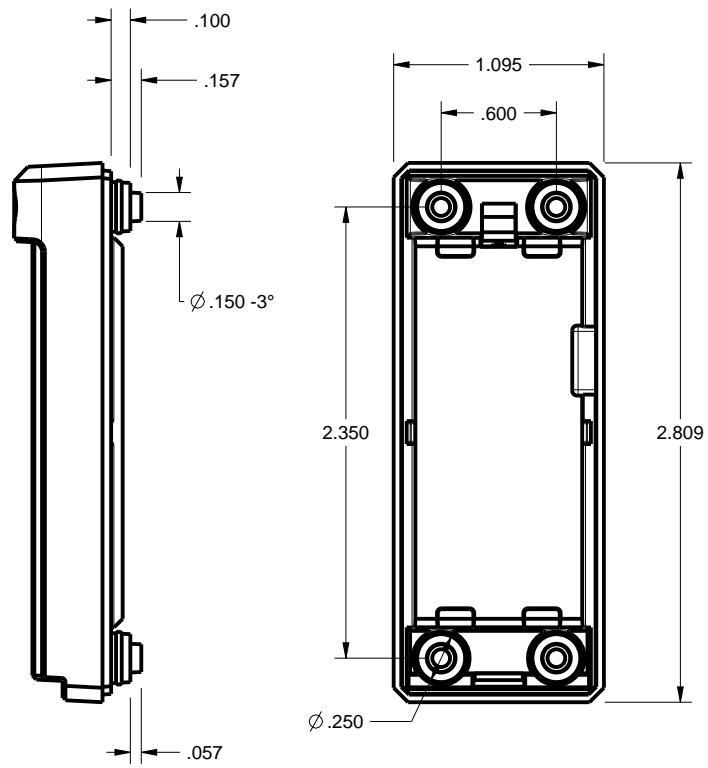
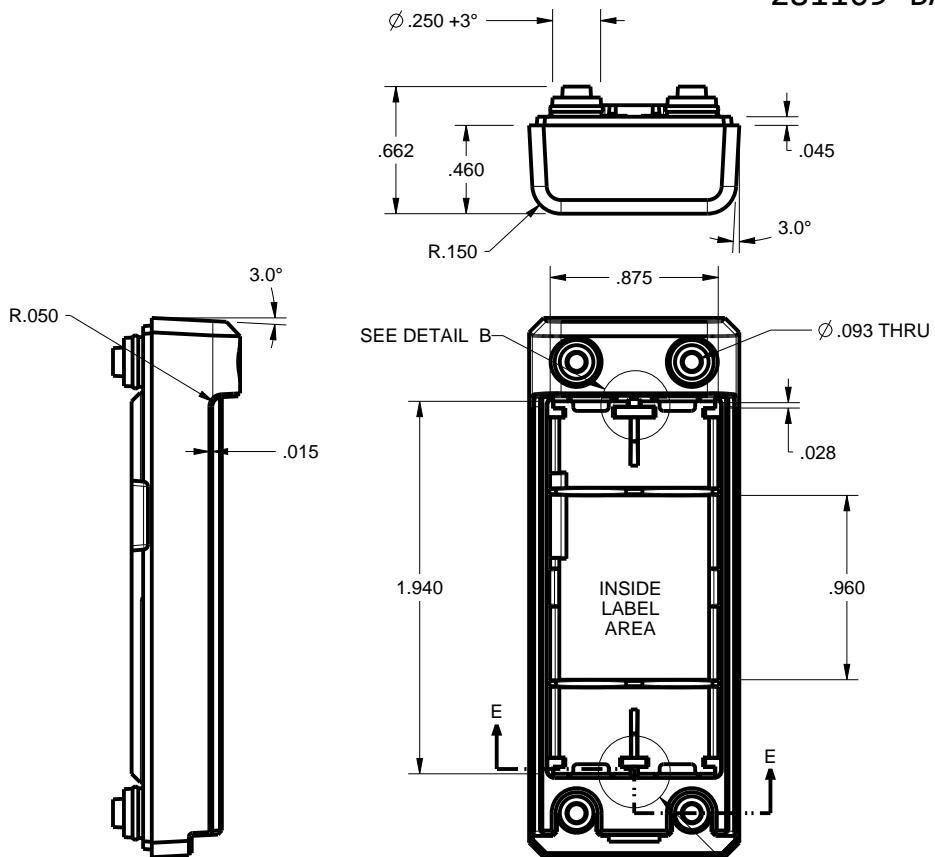

SCALE 1.000 SEE DETAIL C

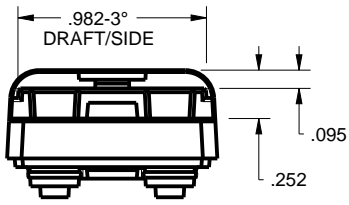
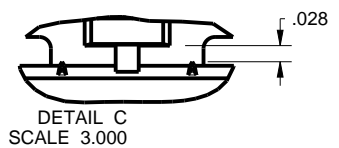
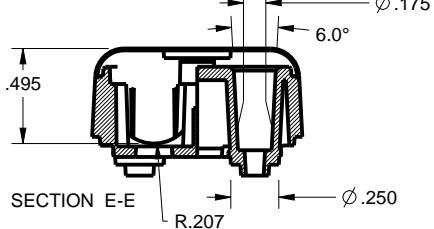
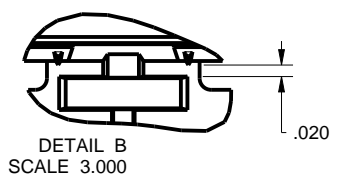

TOLERANCES: UNLESS OTHERWISE SPECIFIED DIMENSIONS ARE IN U.S. INCHES.	
X.XX = .015 X.XXXX = .001	
X.XXX = .010 X.X° = 1°	
NEW AGE ENCLOSURES	
Customer's Part No: 281109	
APPROVAL	BY DATE
CHECK	
ENG.	
SCALE	AS NOTED
DRAWN BY	SIZE
M BOYER	A
2012-Jun-15	DRAWING NAME
	281109_R2_3
SHEET	REV.DOC
4 OF 8	2.3

NEW AGE ENCLOSURES
 4330 Santa Fe Road San Luis Obispo, CA. 93401
 ph. (805) 595-1310 fax (805) 595-1024
www.newageenclosures.com

**STANDARD - COMPACT AAA
 SXX-281109X-XXX**

281109 HATCH

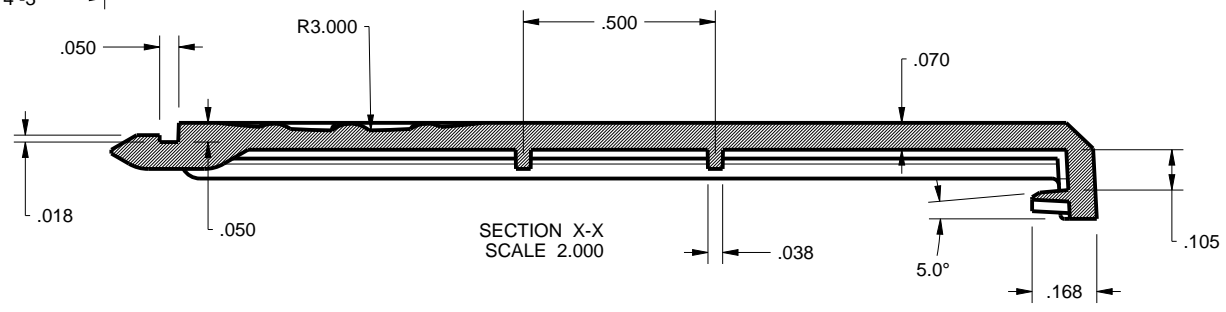
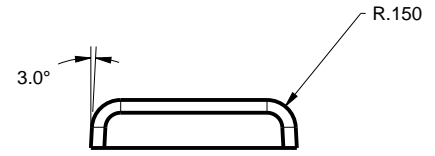
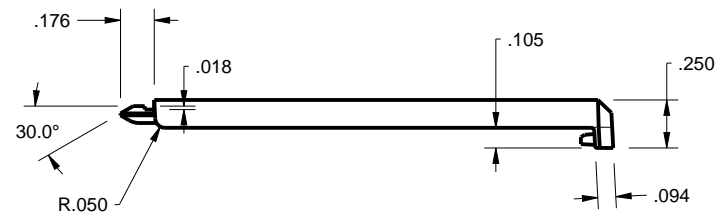
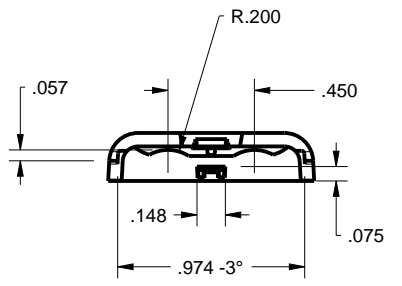
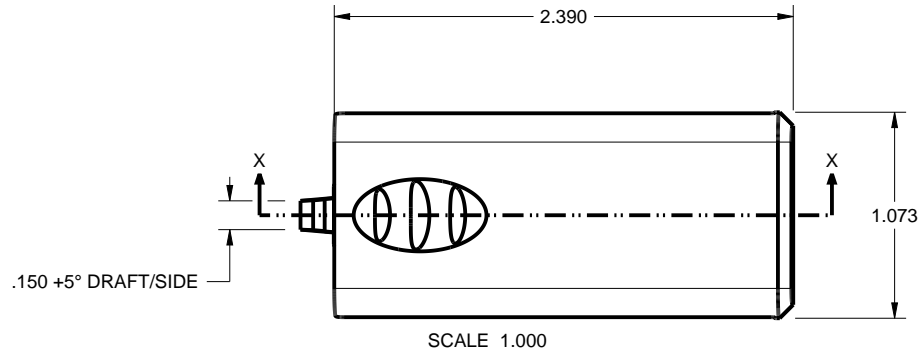

TOLERANCES: UNLESS OTHERWISE SPECIFIED
DIMENSIONS ARE IN U.S. INCHES.
X.XX = .015 X.XXXX = .001
X.XXX = .010 X.X° = 1°

NEW AGE ENCLOSURES
Customer's Part No: 281109

APPROVAL	BY	DATE
CHECK		
ENG.		
SCALE	AS NOTED	
DRAWN BY	2012-Jun-15	
M BOYER		

NEW AGE ENCLOSURES
4330 Santa Fe Road San Luis Obispo, CA. 93401
ph. (805) 595-1310 fax (805) 595-1024
www.newageenclosures.com

**STANDARD - COMPACT AAA
SXX-281109X-XXX**

SIZE	DRAWING NAME	SHEET	REV.DOC
A	281109_R2_3	5 OF 8	2.3

281109 PCB - CUSTOMER SUPPLIED

PCB SIZES ARE RECOMMENDATIONS ONLY. FINAL SIZES AND VERIFICATION OF IT'S FIT ARE THE SOLE RESPONSIBILITY OF THE OEM.

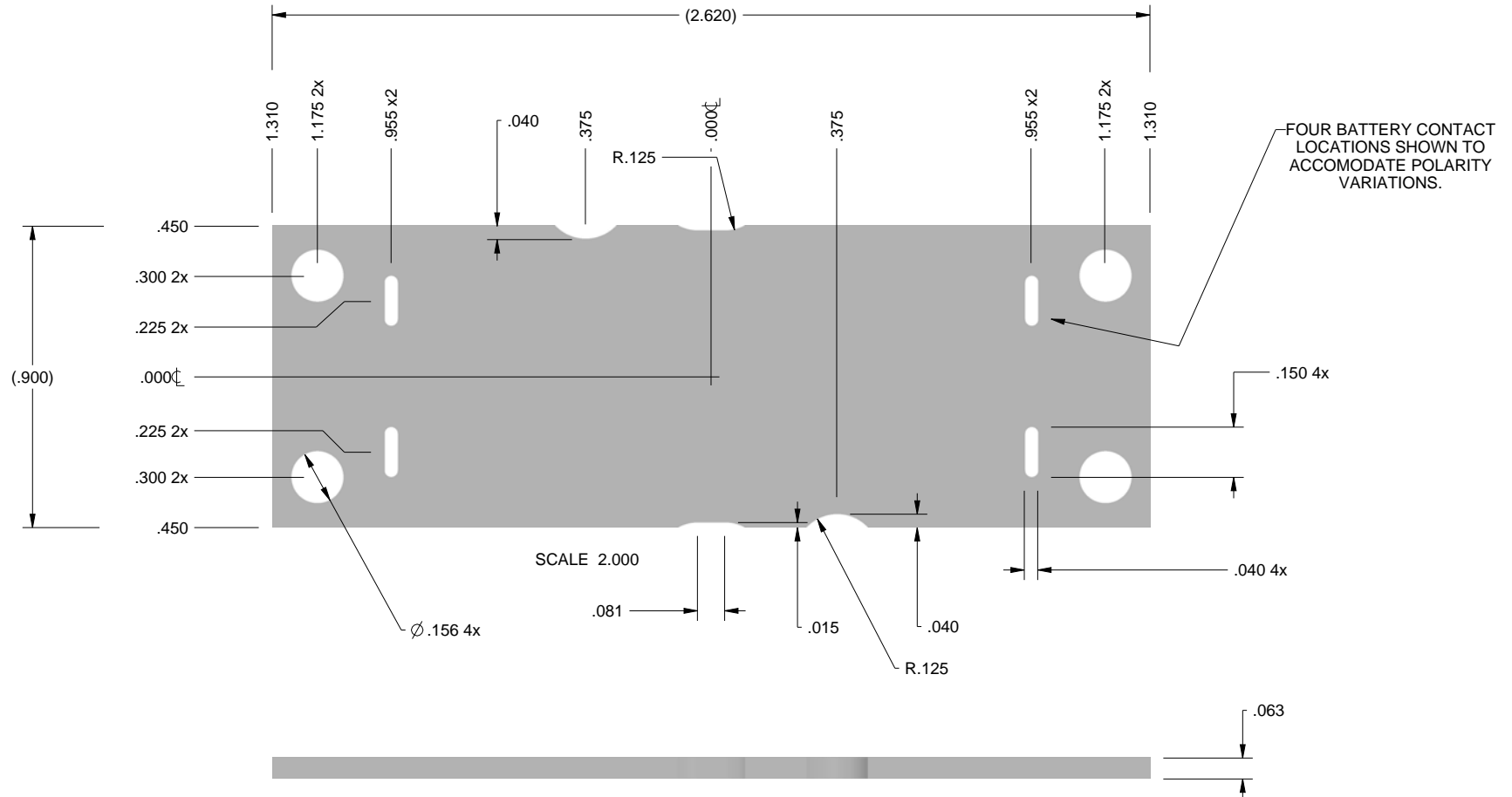

NOTE
1. BATTERY CONNECTION POINTS SHOWN AT BOTH ENDS TO ALLOW ALTERNATE ASSEMBLY OPTION.

TOLERANCES: UNLESS OTHERWISE SPECIFIED DIMENSIONS ARE IN U.S. INCHES. X.XX = .015 X.XXXX = .001 X.XXX = .010 X.X° = 1°		NEW AGE ENCLOSURES	
Customer's Part No: 281109		4330 Santa Fe Road San Luis Obispo, CA. 93401 ph. (805) 595-1310 fax (805) 595-1024 www.newageenclosures.com	
APPROVAL	BY	DATE	STANDARD - COMPACT AAA SXX-281109X-XXX
CHECK			
ENG.			
SCALE	AS NOTED		
DRAWN BY	2012-Jun-15	SIZE	DRAWING NAME
M BOYER		A	281109_R2_3
		SHEET	REV.DOC
		6 OF 8	2.3

281109 WALL CRADLE & 281109 BATTERY BASE

2nd OPERATION DETAILS - PAGE 1 of 2

NEW AGE ENCLOSURES DELIVERS YOUR ENCLOSURE MARKET-READY WITH IN-HOUSE CNC MACHINING, PAD PRINTING, ASSEMBLY, AND FULFILLMENT.
 ALL SURFACES AND AREAS ARE AVAILABLE FOR CNC ALTERATION BY NEW AGE ENCLOSURES
 CALL (805) 595-1310 FOR PRICING AND SCHEDULE.
 THE INSIDE RADIUS OF ANY MACHINED FEATURES SHOULD BE NO SMALLER THAN .031"

281109(x) CONFIGURATIONS

	-Blank	-K	-W
281109 COVER	1	1	
281109 BASE	1		
281109 BASE MODIFIED (2nd OP)		1	
281109 WALL CRADLE			1
281109 HATCH	1	1	
#2 HiLo SCREW .312"	4	4	

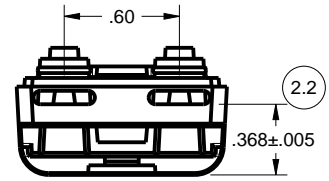
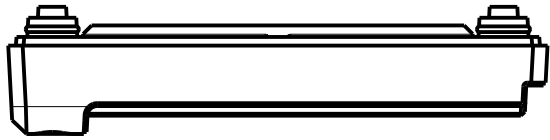
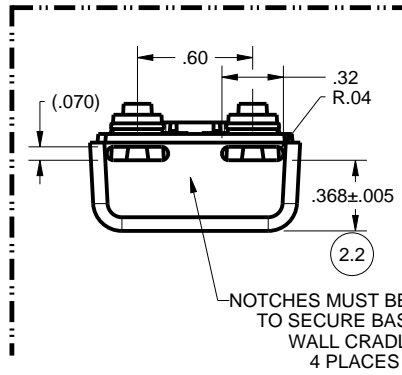
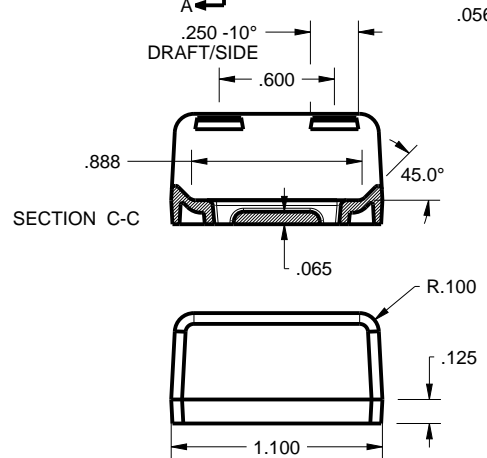
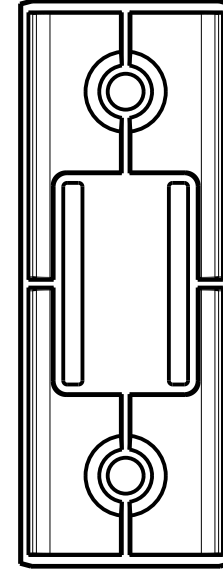
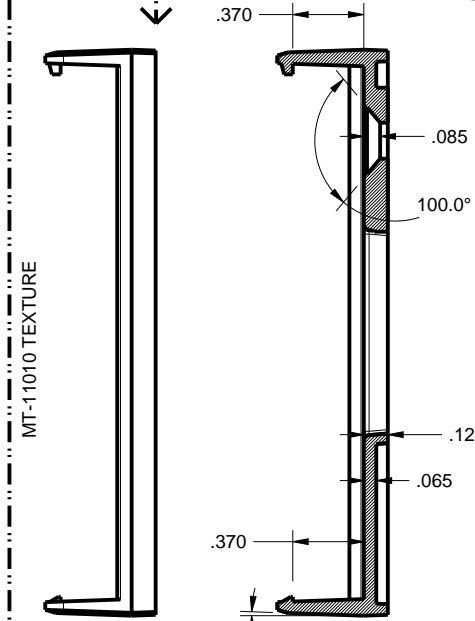
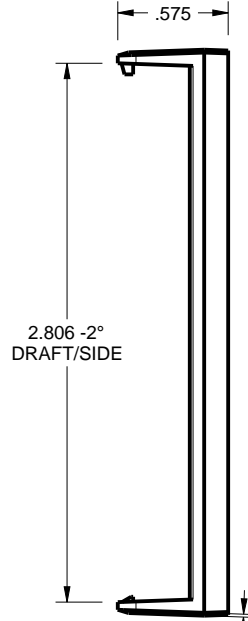
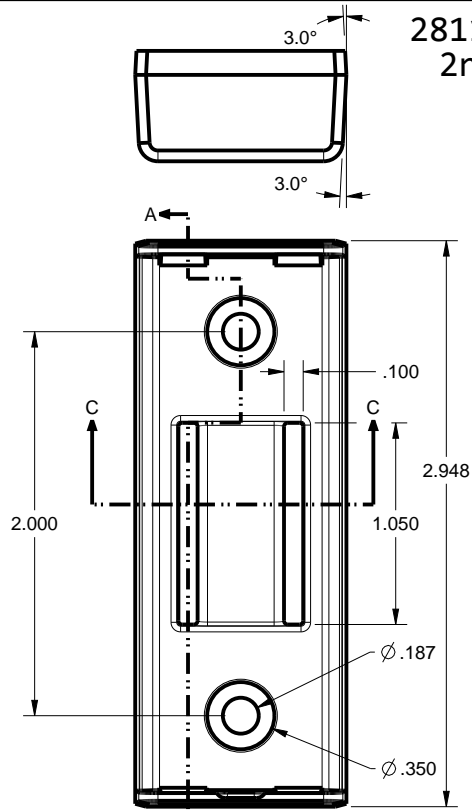

NOTCHES MUST BE ADDED TO SECURE BASE TO WALL CRADLE 4 PLACES

TOLERANCES: UNLESS OTHERWISE SPECIFIED DIMENSIONS ARE IN U.S. INCHES.
 X.XX = .015 X.XXXX = .001
 X.XXX = .010 X.X° = 1°

NEW AGE ENCLOSURES
 Customer's Part No: 281109

NEW AGE ENCLOSURES
 4330 Santa Fe Road San Luis Obispo, CA. 93401
 ph. (805) 595-1310 fax (805) 595-1024
www.newageenclosures.com

SXX-281109-XXX BASE - ABS, BLACK					
STEP NO	DESCRIPTION	CUTTER	FIXTURE	ORIENTATION	PROGRAM
1-B-C1	2 WALL SLOTS ON END	T2 = .062" EM	297	DUAL	o4901
2-B-C2	2 WALL SLOTS ON END	T2 = .062" EM	297	DUAL	o4901

APPROVAL	BY	DATE
CHECK		
ENG.		
SCALE	AS NOTED	
DRAWN BY	M BOYER	
	2012-Jun-15	

STANDARD - COMPACT AAA			
SXX-281109X-XXX			
SIZE	DRAWING NAME	SHEET	REV.DOC
A	281109_R2_3	7 OF 8	2.3

2nd OPERATION DETAILS - PAGE 2 of 2

NEW AGE ENCLOSURES DELIVERS YOUR ENCLOSURE MARKET-READY WITH IN-HOUSE
CNC MACHINING, PAD PRINTING, ASSEMBLY, AND FULFILLMENT.
ALL SURFACES AND AREAS ARE AVAILABLE FOR CNC ALTERATION BY NEW AGE ENCLOSURES
CALL (805) 595-1310 FOR PRICING AND SCHEDULE.
THE INSIDE RADIUS OF ANY MACHINED FEATURES SHOULD BE NO SMALLER THAN .031"

281109(x) CONFIGURATIONS

	-Blank	-K	-W
281109 COVER	1	1	
281109 BASE	1		
281109 BASE MODIFIED (2nd OP)		1	
281109 WALL CRADLE		1	1
281109 HATCH	1	1	
#2 HiLo SCREW .312"	4	4	

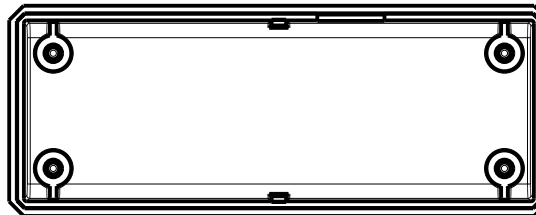
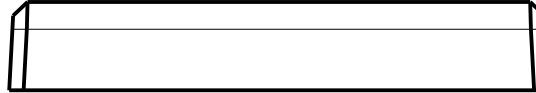
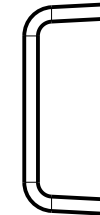
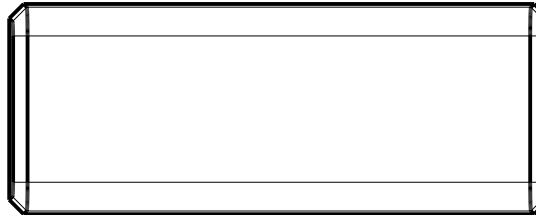
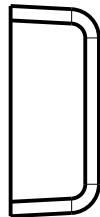

281109 COVER
SCALE 1.000

SXX-281109-XXX COVER - ABS, BLACK

STEP NO	DESCRIPTION	CUTTER	FIXTURE	ORIENTATION	PROGRAM
1-C-C1	-	T2 = .062" EM	290	-	-
2-C-C2	-	T2 = .062" EM	290	-	-

SXX-281109-XXX COVER - ABS, BLACK

STEP NO	DESCRIPTION	INK COLOR	FIXTURE	CLICHE DESCRIPTION	CLICHE No.
3-C-P1	PAD PRINT		291		--

TOLERANCES: UNLESS OTHERWISE SPECIFIED
DIMENSIONS ARE IN U.S. INCHES.
X.XX = .015 X.XXXX = .001
X.XXX = .010 X.X" = 1°

NEW AGE ENCLOSURES

Customer's Part No: 281109

APPROVAL BY DATE

CHECK ENG. SCALE AS NOTED

DRAWN BY M BOYER 2012-Jun-15

NEW AGE ENCLOSURES

4330 Santa Fe Road San Luis Obispo, CA. 93401
ph. (805) 595-1310 fax (805) 595-1024
www.newageenclosures.com

STANDARD - COMPACT AAA SXX-281109X-XXX

SIZE A	DRAWING NAME 281109_R2_3	SHEET 8 OF 8	REV.DOC 2.3
--------	--------------------------	--------------	-------------

Mouser Electronics

Authorized Distributor

Click to View Pricing, Inventory, Delivery & Lifecycle Information:

[New Age Enclosures:](#)

[S3A-281109-K](#) [S1A-281109-K](#)

Компания «Life Electronics» занимается поставками электронных компонентов импортного и отечественного производства от производителей и со складов крупных дистрибьюторов Европы, Америки и Азии.

С конца 2013 года компания активно расширяет линейку поставок компонентов по направлению коаксиальный кабель, кварцевые генераторы и конденсаторы (керамические, пленочные, электролитические), за счёт заключения дистрибьюторских договоров

Мы предлагаем:

- Конкурентоспособные цены и скидки постоянным клиентам.
- Специальные условия для постоянных клиентов.
- Подбор аналогов.
- Поставку компонентов в любых объемах, удовлетворяющих вашим потребностям.
- Приемлемые сроки поставки, возможна ускоренная поставка.
- Доставку товара в любую точку России и стран СНГ.
- Комплексную поставку.
- Работу по проектам и поставку образцов.
- Формирование склада под заказчика.
- Сертификаты соответствия на поставляемую продукцию (по желанию клиента).
- Тестирование поставляемой продукции.
- Поставку компонентов, требующих военную и космическую приемку.
- Входной контроль качества.
- Наличие сертификата ISO.

В составе нашей компании организован Конструкторский отдел, призванный помогать разработчикам, и инженерам.

Конструкторский отдел помогает осуществить:

- Регистрацию проекта у производителя компонентов.
- Техническую поддержку проекта.
- Защиту от снятия компонента с производства.
- Оценку стоимости проекта по компонентам.
- Изготовление тестовой платы монтаж и пусконаладочные работы.



Тел: +7 (812) 336 43 04 (многоканальный)

Email: org@lifeelectronics.ru