

# 4-Channel Charge Pump White LED Driver with 64 Dimming Steps and 1-wire Serial Interface

## BD1601MUV

### ●General Description

The multi-level brightness control white LED driver not only ensures efficient boost by automatically changing the boost rate but also works as a constant current driver in 64 steps, so that the driving current can be adjusted finely. This IC is best suited to turn on white LEDs that require high-accuracy LED brightness control.

### ●Features

- Built-in parallel LED driver for 4 lamps.
- 64-step LED current adjusts function.
- Inter-LED relative current accuracy: 3% or less
- Lighting/dimming control via a single-line digital control interface.
- Automatic transition charge pump type DC/DC converter (×1,×1.5 and ×2).
- High efficiency achieved (90% or more at maximum).
- Various protection functions such as output voltage protection, over current limiter and thermal shutdown circuit are mounted.

### ●Key Specifications

- Operating power supply voltage range: 2.7V to 5.5V
- LED maximum current: 30mA (Typ.)
- Oscillator frequency: 1.0MHz(Typ.)
- Quiescent Current: 0.1μA (Typ.)
- Operating temperature range: -30°C to +85°C

### ●Package W(Typ.) x D(Typ.) x H(Max.)



**VQFN016V3030**  
3.00mm x 3.00mm x 1.00mm

### ●Applications

This driver is applicable for various fields such as mobile phones, portable game machines and white goods.

### ●Typical Application Circuit

White LED Application (Recommended)

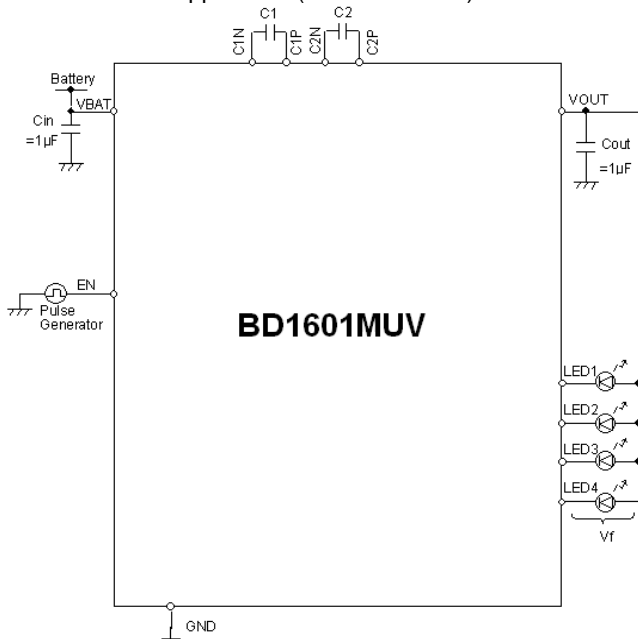

### ●Pin Configuration [Top View]

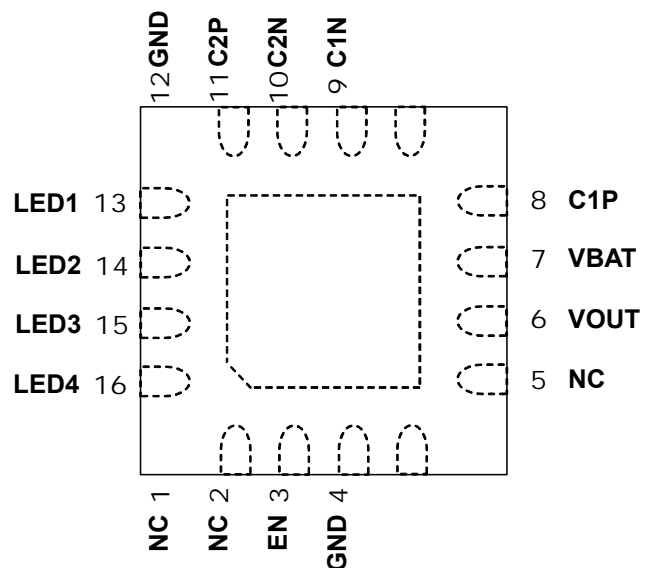

**● Absolute Maximum Ratings (Ta=25°C)**

Parameter	Symbol	Ratings	Unit
Power supply voltage	VMAX	7	V
Operating temperature range	Topr	-30 to +85	°C
Storage temperature range	Tstg	-55 to +150	°C
Power dissipation	Pd	700 <sup>(*)</sup>	mW

(\*) When a glass epoxy substrate (70mm x 70mm x 1.6mm) has been mounted, this loss will decrease 5.6mW/°C if Ta is higher than or equal to 25°C.

**● Recommended Operating Ratings (Ta = -30 to 85°C)**

Parameter	Symbol	Ratings	Unit
Operating power supply voltage	Vin	2.7 to 5.5	V

**● Electrical Characteristics** Unless otherwise noted, Ta = +25°C, VBAT=3.6V

Parameter	Symbol	Limits			Units	Condition
		Min.	Typ.	Max.		
Overall						
Quiescent Current	Iq	-	0.1	1	µA	EN=0V
Current Consumption1	Idd1	-	1.0	2.4	mA	x1.0 Mode, Except LED current
Current Consumption2	Idd2	-	2.5	3.5	mA	x2.0 Mode, Except LED current
Charge Pump						
Oscillator frequency	fOSC	0.8	1.0	1.2	MHz	
Current Source						
LED maximum current	ILED-max	28.5	30	31.5	mA	
LED current accuracy	ILED-diff	-	-	5.0	%	When LED current 15.5mA setting and LED terminal voltage 1.0V
LED current matching <sup>(*)</sup>	ILED-match	-	0.5	3.0	%	When LED current 15.5mA setting and LED terminal voltage 1.0V
LED control voltage	VLED	-	0.2	0.25	V	minimum voltage at LED1 to LED4 pins
Logic control terminal						
Low threshold voltage	VIL	-	-	0.4	V	
High threshold voltage	VIH	1.4	-	-	V	
High level Input current	IiH	-	0.1	2	µA	EN=VBAT
Low level Input current	IiL	-2	-0.1	-	µA	EN=0V
Minimum EN High time	THI	50	-	-	ns	
Minimum EN Low time	TLO	0.05	-	100	µs	
EN Off Timeout	TOFF	-	512	640	µs	

(\*) The following expression is used for calculation:

$$I_{LED-match} = \frac{(I_{max} - I_{min})}{(I_{max} + I_{min})} \times 100$$

I<sub>max</sub>= Current value in a channel with the maximum current value among all channels

I<sub>min</sub>=Current value in a channel with the minimum current value among all channels

●Pin Descriptions

Pin No.	Pin name	In/Out	Type	Function
1	NC	-	-	No connect
2	NC	-	-	No connect
3	EN	In	C	ON/OFF and dimming control
4	GND	-	D	GND
5	NC	-	-	No connect
6	VOUT	Out	A	Charge pump output
7	VBAT	-	A	Power supply
8	C1P	In/Out	A	Flying capacitor pin positive (+) side
9	C1N	In/Out	B	Flying capacitor pin negative (-) side
10	C2N	In/Out	B	Flying capacitor pin negative (-) side
11	C2P	In/Out	A	Flying capacitor pin positive (+) side
12	GND	-	D	GND
13	LED1	Out	B	LED current driver output 1
14	LED2	Out	B	LED current driver output 2
15	LED3	Out	B	LED current driver output 3
16	LED4	Out	B	LED current driver output 4
-	Thermal PAD	-	D	Heat radiation PAD of back side Connect to GND

●Pin ESD Type

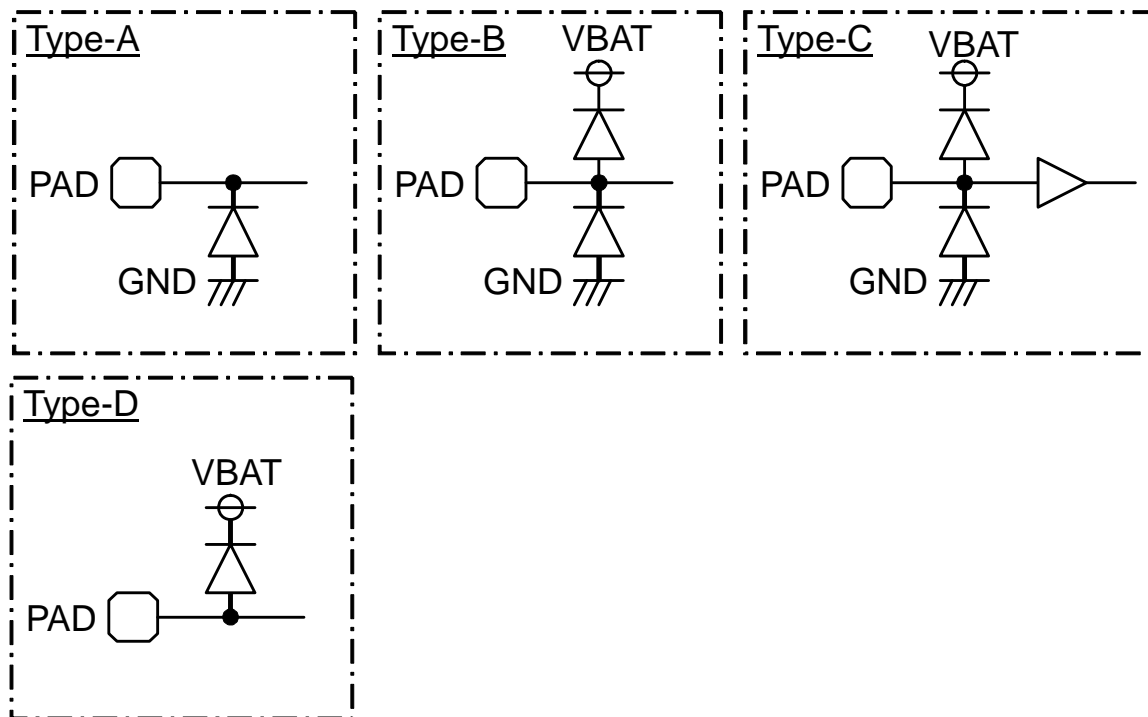
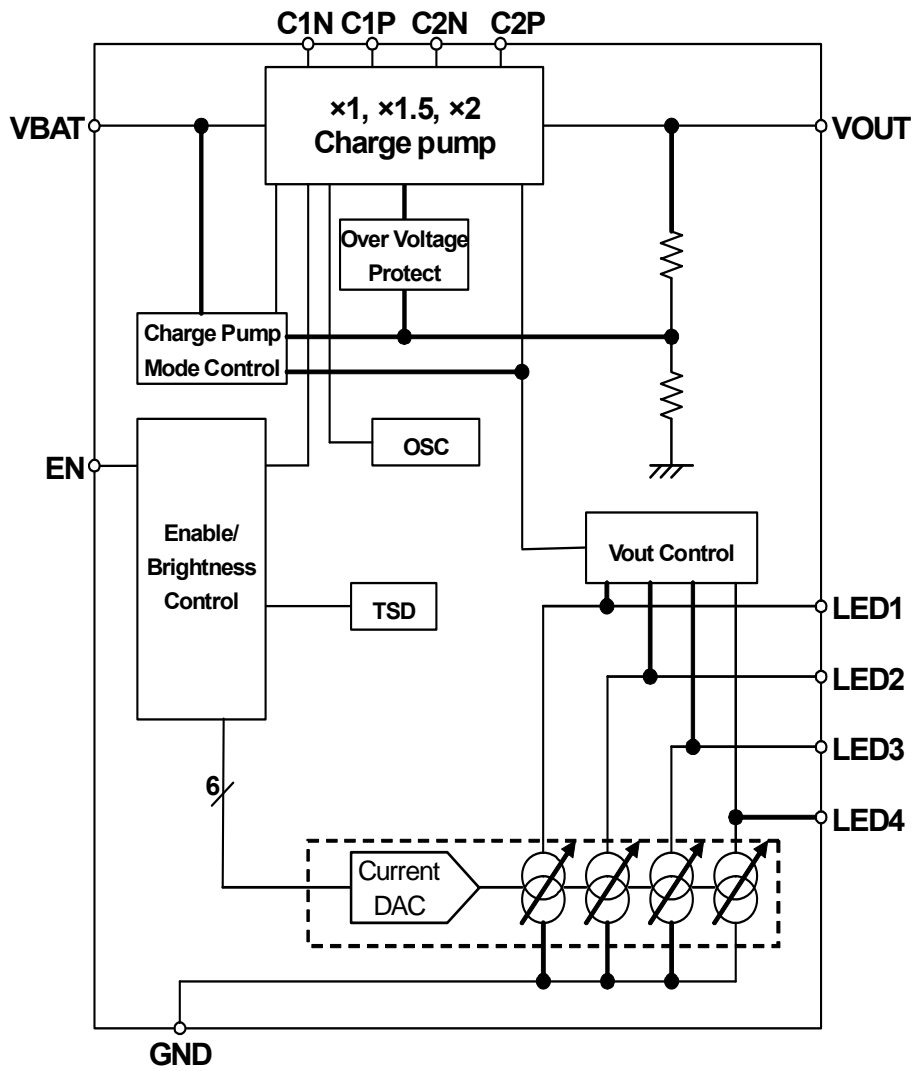

Figure 1. Pin ESD Type

●Block Diagram



● Typical Performance Curves

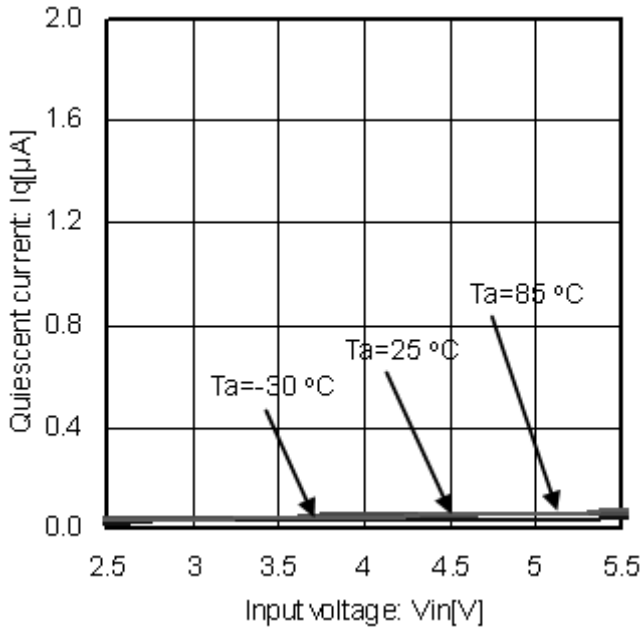

Figure 2. Circuit Current (Standby)

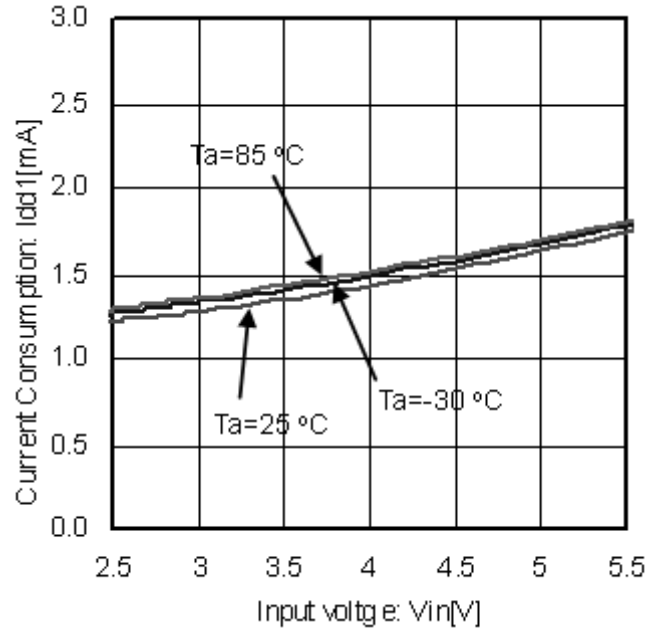

Figure 3. Circuit Current (Operation in x 1.0 Mode)

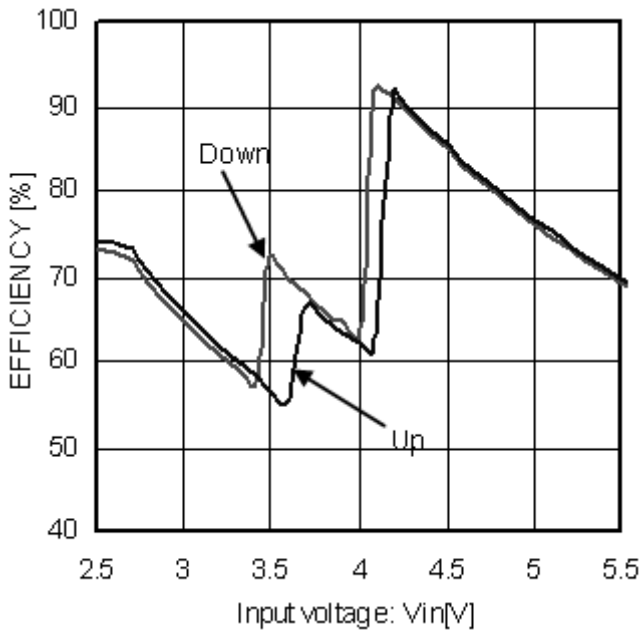

Figure 4. Efficiency (20mA x 4Lights)

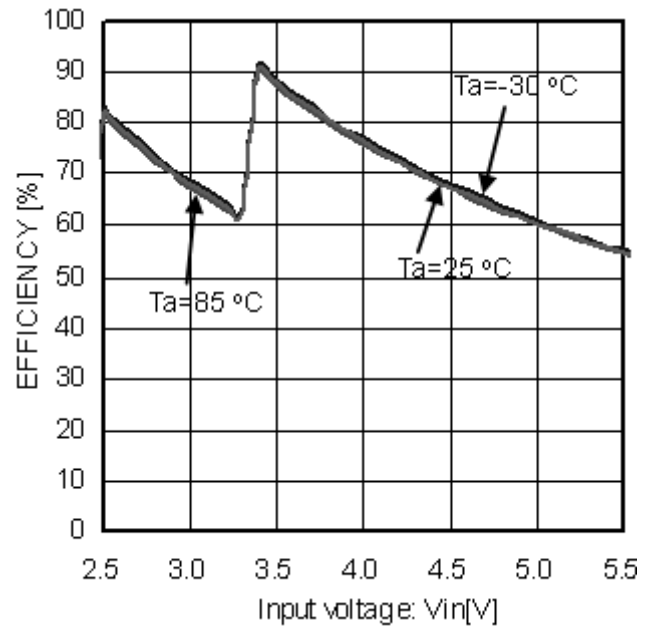

Figure 5. Efficiency (5mA x 4Lights)

● Typical Performance Curves - continued

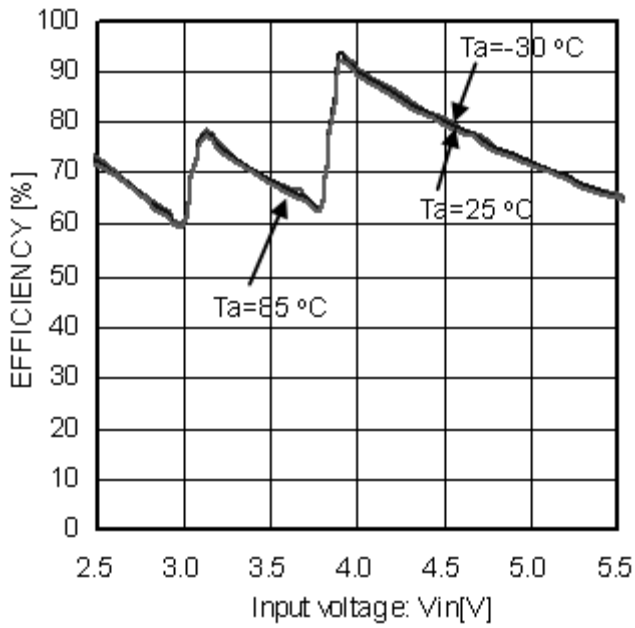

Figure 6. Efficiency (15mA x 4 Lights)

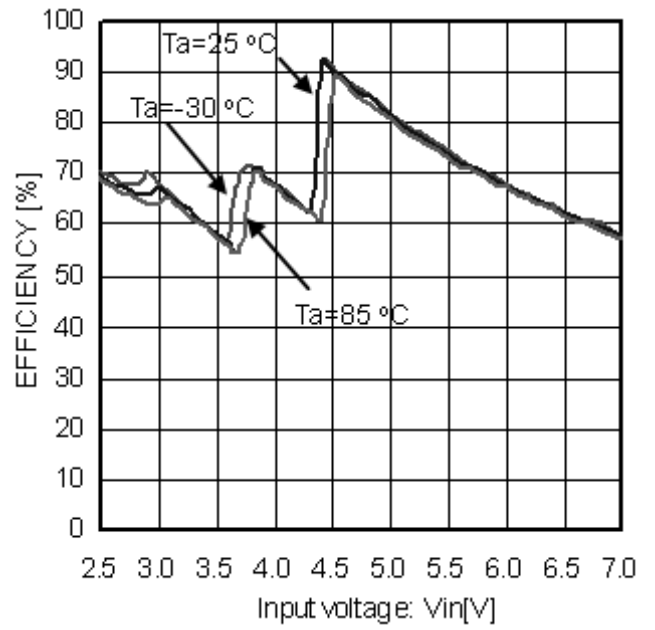

Figure 7. Efficiency (30mA x 4 Lights)

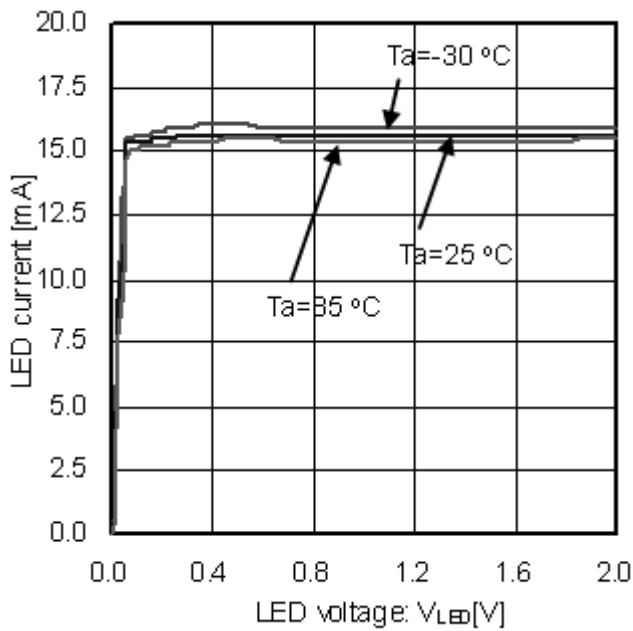

Figure 8. LED Current Characteristics (LED current 15.5mA)

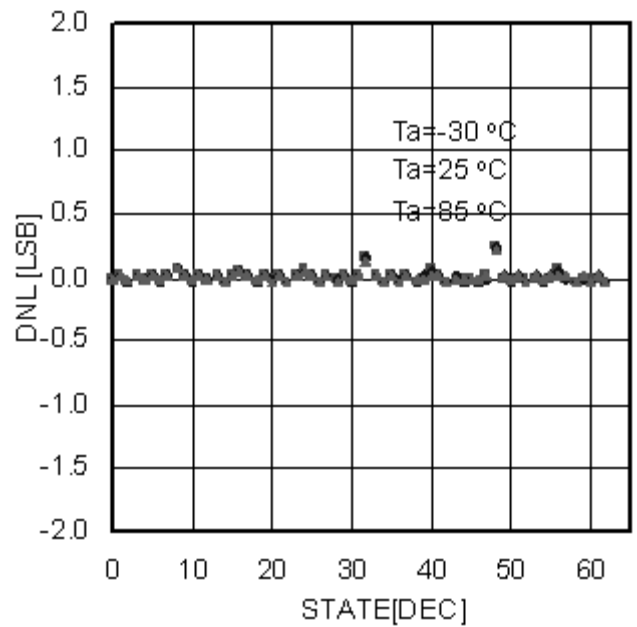

Figure 9. LED Current Characteristics (Differential Linearity error)

● Typical Performance Curves - continued

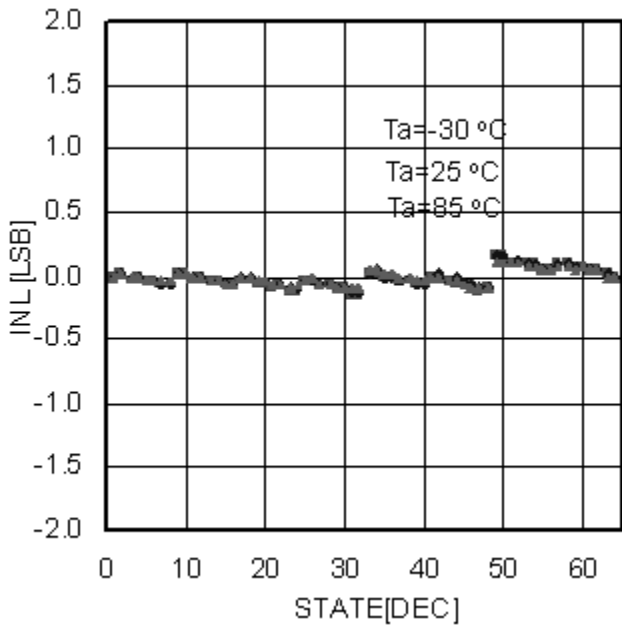

Figure 10. LED Current Characteristics (Integral Linearity Error)

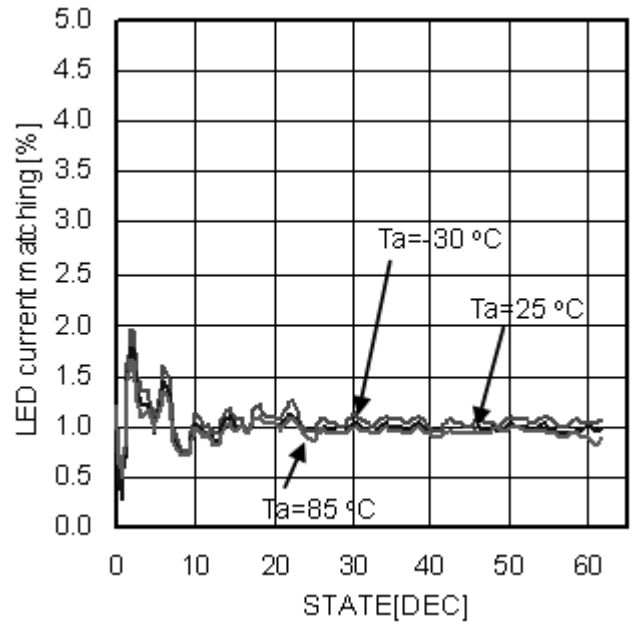

Figure 11. LED current matching

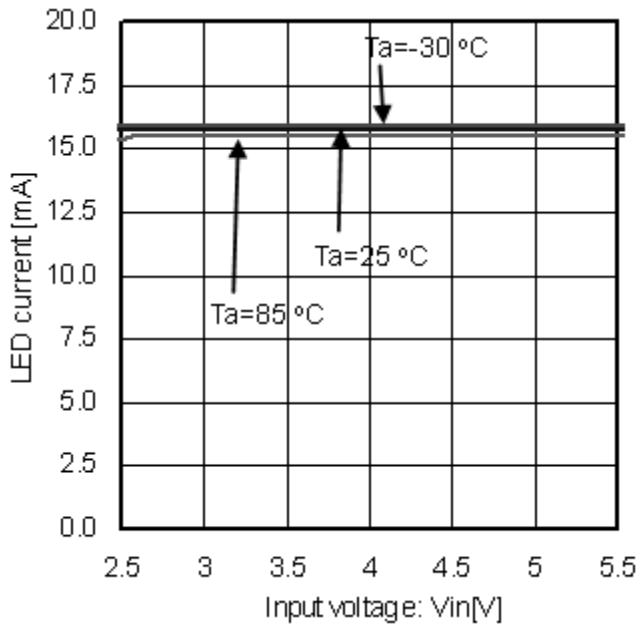

Figure 12. LED Current – Input voltage (LED current 15.5mA)

●Function Description

- (1) LED driver
  - UPIC interface

BD1601MUV is a single line digital interface control (Uni-port Interface Control=UPIC) that can control the power ON/OFF and LED current value through the EN pin only. The LED current increments by about 0.5mA depending on the number of leading edges. When the number of leading edge is added at the maximum output current of 30mA (64 leading edges), the current is almost equal to 0.5mA at startup time. To maintain any output current, the EN pin must be kept at "H" level. To power off, the EN pin must be kept at "L" level for more than 640µsec.

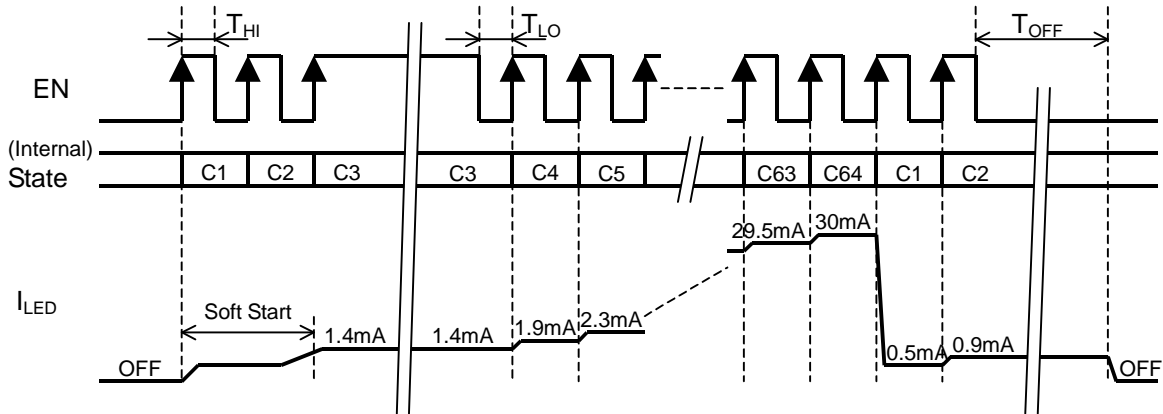

Figure 13. Brightness Control Method

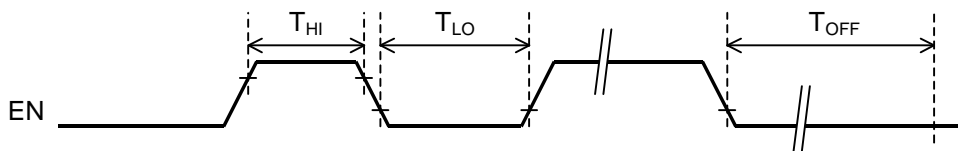

Figure 14. UPIC Interface

- LED current level

The LED current state can be changed by the EN control signal. When the current level is Cn, the basic LED current (ILED) can be obtained from the following expression (where, n indicates a state number).

$$I_{LED} = 30 / 64 \times n \text{ [mA]}$$

State	Output current [mA]	State	Output current [mA]	State	Output current [mA]	State	Output current [mA]
C1	0.5	C14	8.0	C33	15.5	C49	23.0
C2	0.9	C18	8.4	C34	15.9	C50	23.4
C3	1.4	C19	8.9	C35	16.4	C51	23.9
C4	1.9	C20	9.4	C36	16.9	C52	24.4
C5	2.3	C21	9.8	C37	17.3	C53	24.8
C6	2.8	C22	10.3	C38	17.8	C54	25.3
C7	3.3	C23	10.8	C39	18.3	C55	25.8
C8	3.8	C24	11.3	C40	18.8	C56	26.3
C9	4.2	C25	11.7	C41	19.2	C57	26.7
C10	4.7	C26	12.2	C42	19.7	C58	27.2
C11	5.2	C27	12.7	C43	20.2	C59	27.7
C12	5.6	C28	13.1	C44	20.6	C60	28.1
C13	6.1	C29	13.6	C45	21.1	C61	28.6
C14	6.6	C30	14.1	C46	21.6	C62	29.1
C15	7.0	C31	14.5	C47	22.0	C63	29.5
C16	7.5	C32	15.0	C48	22.5	C64	30.0



(2) Charge pump

a) Description of operations

Pin voltage comparison takes place at VOUT control section, and then VOUT generation takes place so that the LED cathode voltage with the highest Vf is set to 0.2V. A boost rate is changed automatically to a proper one at the Charge Pump Mode Control section so that operation can take place at possible low boost rate. When the current taken from VBAT exceeds 600mA, the overcurrent limiter is activated and this IC is reset. In addition, if the output voltage falls below 1.5V, this IC is reset for short-circuit at output.

b) Soft start function

BD1601MUV have a soft start function that prevents the rush current.

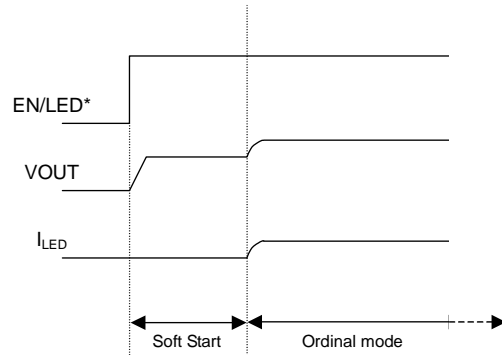

Figure 15. Soft Start

c) Automatic boost rate change

The boost rate automatically switches to the best mode.

**\* (×1 mode -> ×1.5 mode) or (×1.5 mode -> ×2 mode)**

If a battery voltage drop occurs BD1601MUV cannot maintain the LED constant current, and then mode transition begins.

**\* (×1.5 mode -> ×1 mode) or (×2 mode -> ×1.5 mode)**

If a battery voltage rise occurs, VOUT and VBAT detection are activated, and then mode transition begins.

(3) UVLO (Ultra low Voltage Lock Out)

If the input voltage falls below 2.2V, BD1601MUV is shut down to prevent malfunction due to ultra-low voltage.

(4) OVP (Over Voltage Protection)

This circuit protects this IC against damage when the C/P output voltage (VOUT) rises extremely for some external factors.

(5) Thermal shutdown (TSD)

To protect this IC against thermal damage or heat-driven uncontrolled operations, this circuit turns off the output if the chip temperature rises over 175°C. In addition, it turns on the output if the temperature returns to the normal temperature.

(6) Power sequence

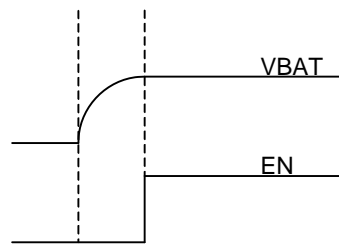

\*VBAT voltage  $\geq$  EN voltage

Figure 16. Power sequence

●Application Circuit Example

White LED Application(VOUT not used)

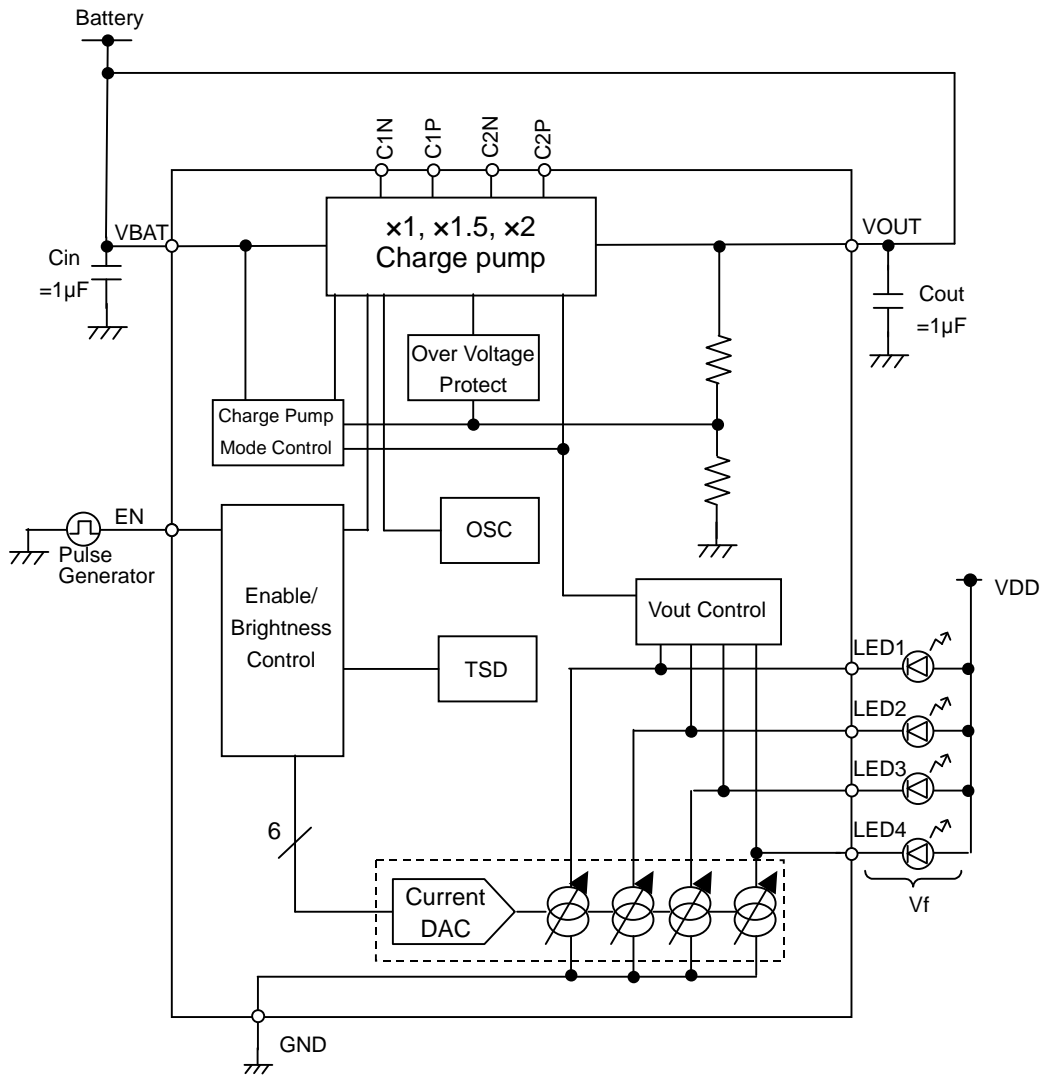

Figure 17. Block Diagram and Circuit Example

●Selection of Components Externally Connected

Capacitor (Use a ceramics capacitor with good frequency and temperature characteristics.)

Symbol	Recommended value	Recommended parts	Type
Cout,Cin,C1,C2	1µF	GRM188B11A105KA61B(MURATA)	Ceramics capacitor

Connect an input bypass capacitor  $C_{in}$  between VBAT and GND pin and an output capacitor  $C_{out}$  between VOUT and GND pin in proximity. Place both C1P-C1N and C2P-C2N capacitors in proximity to the chip. Furthermore, select a ceramics capacitor with a sufficient rating for voltage to be applied.

When the parts not listed above are used, the equivalent parts must be used.

●Recommended PCB Layout

In PCB design, wire the power supply line in a way that the PCB impedance goes low and provide a bypass capacitor if needed. Heat radiation of back side PAD is used for improving the efficiency of IC heat radiation. Solder PAD to GND pin. Moreover, connect ground plane of board using via as shown in the patterns of below page. The efficiency of heat radiation improves according to the area of ground plane.

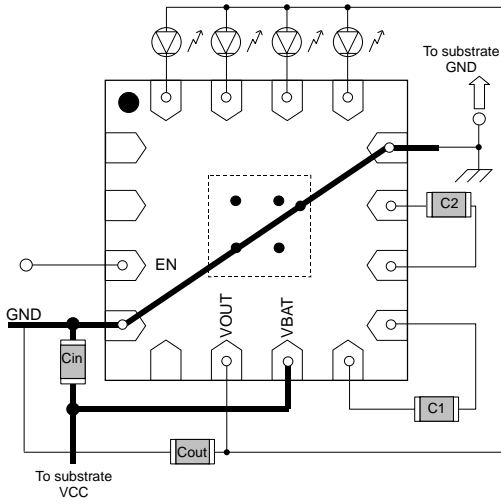

Figure 18. Application Layout Image (Top View)

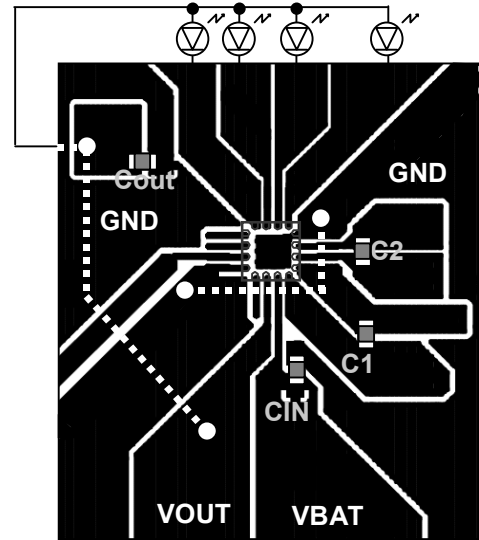

Figure 19. BD1601MUV Front (Top View)

**●Operational Notes**

- (1) Absolute Maximum Ratings  
An excess in the absolute maximum ratings, such as supply voltage, temperature range of operating conditions, etc., can break down devices, thus making impossible to identify breaking mode such as a short circuit or an open circuit. If any special mode exceeding the absolute maximum ratings is assumed, consideration should be given to take physical safety measures including the use of fuses, etc.
- (2) Operating conditions  
These conditions represent a range within which characteristics can be provided approximately as expected. The electrical characteristics are guaranteed under the conditions of each parameter.
- (3) Reverse connection of power supply connector  
The reverse connection of power supply connector can break down ICs. Take protective measures against the breakdown due to the reverse connection, such as mounting an external diode between the power supply and the IC's power supply terminal.
- (4) Power supply line  
Design PCB pattern to provide low impedance for the wiring between the power supply and the GND lines. Furthermore, for all power supply terminals to ICs, mount a capacitor between the power supply and the GND terminal. At the same time, in order to use an electrolytic capacitor, thoroughly check to be sure the characteristics of the capacitor to be used present no problem including the occurrence of capacity dropout at a low temperature, thus determining the constant.
- (5) GND voltage  
Make setting of the potential of the GND terminal so that it will be maintained at the minimum in any operating state. Furthermore, check to be sure no terminals are at a potential lower than the GND voltage including an actual electric transient.
- (6) Short circuit between terminals and erroneous mounting  
In order to mount ICs on a set PCB, pay thorough attention to the direction and offset of the ICs. Erroneous mounting can break down the ICs. Furthermore, if a short circuit occurs due to foreign matters entering between terminals or between the terminal and the power supply or the GND terminal, the ICs can break down.
- (7) Operation in strong electromagnetic field  
Be noted that using ICs in the strong electromagnetic field can malfunction them.
- (8) Inspection with set PCB  
On the inspection with the set PCB, if a capacitor is connected to a low-impedance IC terminal, the IC can suffer stress. Therefore, be sure to discharge from the set PCB by each process. Furthermore, in order to mount or dismount the set PCB to/from the jig for the inspection process, be sure to turn OFF the power supply and then mount the set PCB to the jig. After the completion of the inspection, be sure to turn OFF the power supply and then dismount it from the jig. In addition, for protection against static electricity, establish a ground for the assembly process and pay thorough attention to the transportation and the storage of the set PCB.
- (9) Input terminals  
In terms of the construction of IC, parasitic elements are inevitably formed in relation to potential. The operation of the parasitic element can cause interference with circuit operation, thus resulting in a malfunction and then breakdown of the input terminal. Therefore, pay thorough attention not to handle the input terminals, such as to apply to the input terminals a voltage lower than the GND respectively, so that any parasitic element will operate. Furthermore, do not apply a voltage to the input terminals when no power supply voltage is applied to the IC. In addition, even if the power supply voltage is applied, apply to the input terminals a voltage lower than the power supply voltage or within the guaranteed value of electrical characteristics.
- (10) Ground wiring pattern  
If small-signal GND and large-current GND are provided, It will be recommended to separate the large-current GND pattern from the small-signal GND pattern and establish a single ground at the reference point of the set PCB so that resistance to the wiring pattern and voltage fluctuations due to a large current will cause no fluctuations in voltages of the small-signal GND. Pay attention not to cause fluctuations in the GND wiring pattern of external parts as well.
- (11) External capacitor  
In order to use a ceramic capacitor as the external capacitor, determine the constant with consideration given to a degradation in the nominal capacitance due to DC bias and changes in the capacitance due to temperature, etc.
- (12) Thermal shutdown circuit (TSD)  
When junction temperatures become 175°C (typ) or higher, the thermal shutdown circuit operates and turns a switch OFF. The thermal shutdown circuit, which is aimed at isolating the LSI from thermal runaway as much as possible, is not aimed at the protection or guarantee of the LSI. Therefore, do not continuously use the LSI with this circuit operating or use the LSI assuming its operation.
- (13) Thermal design  
Perform thermal design in which there are adequate margins by taking into account the permissible dissipation (Pd) in actual states of use.

**Status of this document**

The Japanese version of this document is formal specification. A customer may use this translation version only for a reference to help reading the formal version.

If there are any differences in translation version of this document formal version takes priority.

● Ordering Information

B D 1 6 0 1 M U V

 - E 2

Part Number	Package MUV: VQFN016V3030	Packaging and forming specification E2: Embossed tape and reel
-------------	------------------------------	---

● Marking Diagram

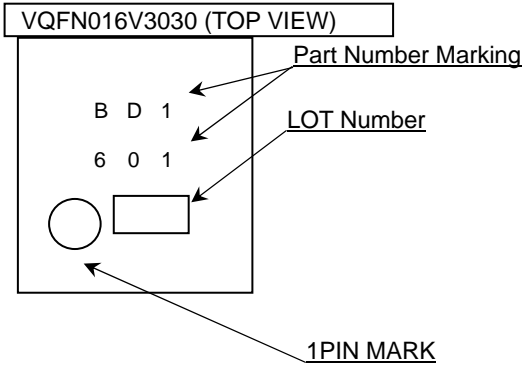

● Physical Dimension Tape and Reel Information

VQFN016V3030

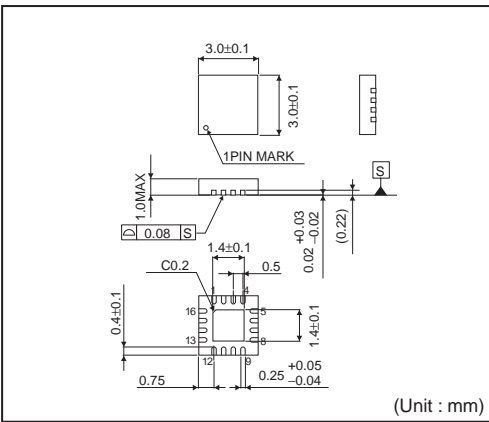

<Tape and Reel information>

Tape	Embossed carrier tape
Quantity	3000pcs
Direction of feed	E2 ( The direction is the 1pin of product is at the upper left when you hold reel on the left hand and you pull out the tape on the right hand )

\* Order quantity needs to be multiple of the minimum quantity.

●Revision History

Date	Revision	Changes
05.Nov.2012	001	New Release

# Notice

## ●General Precaution

- 1) Before you use our Products, you are requested to carefully read this document and fully understand its contents. ROHM shall not be in any way responsible or liable for failure, malfunction or accident arising from the use of any ROHM's Products against warning, caution or note contained in this document.
- 2) All information contained in this document is current as of the issuing date and subject to change without any prior notice. Before purchasing or using ROHM's Products, please confirm the latest information with a ROHM sales representative.

## ●Precaution on using ROHM Products

- 1) Our Products are designed and manufactured for application in ordinary electronic equipments (such as AV equipment, OA equipment, telecommunication equipment, home electronic appliances, amusement equipment, etc.). If you intend to use our Products in devices requiring extremely high reliability (such as medical equipment, transport equipment, traffic equipment, aircraft/spacecraft, nuclear power controllers, fuel controllers, car equipment including car accessories, safety devices, etc.) and whose malfunction or failure may cause loss of human life, bodily injury or serious damage to property ("Specific Applications"), please consult with the ROHM sales representative in advance. Unless otherwise agreed in writing by ROHM in advance, ROHM shall not be in any way responsible or liable for any damages, expenses or losses incurred by you or third parties arising from the use of any ROHM's Products for Specific Applications.
- 2) ROHM designs and manufactures its Products subject to strict quality control system. However, semiconductor products can fail or malfunction at a certain rate. Please be sure to implement, at your own responsibilities, adequate safety measures including but not limited to fail-safe design against the physical injury, damage to any property, which a failure or malfunction of our Products may cause. The following are examples of safety measures:
  - [a] Installation of protection circuits or other protective devices to improve system safety
  - [b] Installation of redundant circuits to reduce the impact of single or multiple circuit failure
- 3) Our Products are designed and manufactured for use under standard conditions and not under any special or extraordinary environments or conditions, as exemplified below. Accordingly, ROHM shall not be in any way responsible or liable for any damages, expenses or losses arising from the use of any ROHM's Products under any special or extraordinary environments or conditions. If you intend to use our Products under any special or extraordinary environments or conditions (as exemplified below), your independent verification and confirmation of product performance, reliability, etc. prior to use, must be necessary:
  - [a] Use of our Products in any types of liquid, including water, oils, chemicals, and organic solvents
  - [b] Use of our Products outdoors or in places where the Products are exposed to direct sunlight or dust
  - [c] Use of our Products in places where the Products are exposed to sea wind or corrosive gases, including Cl<sub>2</sub>, H<sub>2</sub>S, NH<sub>3</sub>, SO<sub>2</sub>, and NO<sub>2</sub>
  - [d] Use of our Products in places where the Products are exposed to static electricity or electromagnetic waves
  - [e] Use of our Products in proximity to heat-producing components, plastic cords, or other flammable items
  - [f] Sealing or coating our Products with resin or other coating materials
  - [g] Use of our Products without cleaning residue of flux (even if you use no-clean type fluxes, cleaning residue of flux is recommended); or Washing our Products by using water or water-soluble cleaning agents for cleaning residue after soldering
  - [h] Use of the Products in places subject to dew condensation
- 4) The Products are not subject to radiation-proof design.
- 5) Please verify and confirm characteristics of the final or mounted products in using the Products.
- 6) In particular, if a transient load (a large amount of load applied in a short period of time, such as pulse) is applied, confirmation of performance characteristics after on-board mounting is strongly recommended. Avoid applying power exceeding normal rated power; exceeding the power rating under steady-state loading condition may negatively affect product performance and reliability.
- 7) De-rate Power Dissipation (Pd) depending on Ambient temperature (Ta). When used in sealed area, confirm the actual ambient temperature.
- 8) Confirm that operation temperature is within the specified range described in the product specification.
- 9) ROHM shall not be in any way responsible or liable for failure induced under deviant condition from what is defined in this document.

**●Precaution for Mounting / Circuit board design**

- 1) When a highly active halogenous (chlorine, bromine, etc.) flux is used, the residue of flux may negatively affect product performance and reliability.
- 2) In principle, the reflow soldering method must be used; if flow soldering method is preferred, please consult with the ROHM representative in advance.

For details, please refer to ROHM Mounting specification

**●Precautions Regarding Application Examples and External Circuits**

- 1) If change is made to the constant of an external circuit, please allow a sufficient margin considering variations of the characteristics of the Products and external components, including transient characteristics, as well as static characteristics.
- 2) You agree that application notes, reference designs, and associated data and information contained in this document are presented only as guidance for Products use. Therefore, in case you use such information, you are solely responsible for it and you must exercise your own independent verification and judgment in the use of such information contained in this document. ROHM shall not be in any way responsible or liable for any damages, expenses or losses incurred by you or third parties arising from the use of such information.

**●Precaution for Electrostatic**

This Product is electrostatic sensitive product, which may be damaged due to electrostatic discharge. Please take proper caution in your manufacturing process and storage so that voltage exceeding the Products maximum rating will not be applied to Products. Please take special care under dry condition (e.g. Grounding of human body / equipment / solder iron, isolation from charged objects, setting of Ionizer, friction prevention and temperature / humidity control).

**●Precaution for Storage / Transportation**

- 1) Product performance and soldered connections may deteriorate if the Products are stored in the places where:
  - [a] the Products are exposed to sea winds or corrosive gases, including Cl<sub>2</sub>, H<sub>2</sub>S, NH<sub>3</sub>, SO<sub>2</sub>, and NO<sub>2</sub>
  - [b] the temperature or humidity exceeds those recommended by ROHM
  - [c] the Products are exposed to direct sunshine or condensation
  - [d] the Products are exposed to high Electrostatic
- 2) Even under ROHM recommended storage condition, solderability of products out of recommended storage time period may be degraded. It is strongly recommended to confirm solderability before using Products of which storage time is exceeding the recommended storage time period.
- 3) Store / transport cartons in the correct direction, which is indicated on a carton with a symbol. Otherwise bent leads may occur due to excessive stress applied when dropping of a carton.
- 4) Use Products within the specified time after opening a humidity barrier bag. Baking is required before using Products of which storage time is exceeding the recommended storage time period.

**●Precaution for Product Label**

QR code printed on ROHM Products label is for ROHM's internal use only.

**●Precaution for Disposition**

When disposing Products please dispose them properly using an authorized industry waste company.

**●Precaution for Foreign Exchange and Foreign Trade act**

Since our Products might fall under controlled goods prescribed by the applicable foreign exchange and foreign trade act, please consult with ROHM representative in case of export.

**●Precaution Regarding Intellectual Property Rights**

- 1) All information and data including but not limited to application example contained in this document is for reference only. ROHM does not warrant that foregoing information or data will not infringe any intellectual property rights or any other rights of any third party regarding such information or data. ROHM shall not be in any way responsible or liable for infringement of any intellectual property rights or other damages arising from use of such information or data.:
- 2) No license, expressly or implied, is granted hereby under any intellectual property rights or other rights of ROHM or any third parties with respect to the information contained in this document.



●Other Precaution

- 1) The information contained in this document is provided on an "as is" basis and ROHM does not warrant that all information contained in this document is accurate and/or error-free. ROHM shall not be in any way responsible or liable for any damages, expenses or losses incurred by you or third parties resulting from inaccuracy or errors of or concerning such information.
- 2) This document may not be reprinted or reproduced, in whole or in part, without prior written consent of ROHM.
- 3) The Products may not be disassembled, converted, modified, reproduced or otherwise changed without prior written consent of ROHM.
- 4) In no event shall you use in any way whatsoever the Products and the related technical information contained in the Products or this document for any military purposes, including but not limited to, the development of mass-destruction weapons.
- 5) The proper names of companies or products described in this document are trademarks or registered trademarks of ROHM, its affiliated companies or third parties.

Компания «Life Electronics» занимается поставками электронных компонентов импортного и отечественного производства от производителей и со складов крупных дистрибьюторов Европы, Америки и Азии.

С конца 2013 года компания активно расширяет линейку поставок компонентов по направлению коаксиальный кабель, кварцевые генераторы и конденсаторы (керамические, пленочные, электролитические), за счёт заключения дистрибьюторских договоров

Мы предлагаем:

- Конкурентоспособные цены и скидки постоянным клиентам.
- Специальные условия для постоянных клиентов.
- Подбор аналогов.
- Поставку компонентов в любых объемах, удовлетворяющих вашим потребностям.
- Приемлемые сроки поставки, возможна ускоренная поставка.
- Доставку товара в любую точку России и стран СНГ.
- Комплексную поставку.
- Работу по проектам и поставку образцов.
- Формирование склада под заказчика.
- Сертификаты соответствия на поставляемую продукцию (по желанию клиента).
- Тестирование поставляемой продукции.
- Поставку компонентов, требующих военную и космическую приемку.
- Входной контроль качества.
- Наличие сертификата ISO.

В составе нашей компании организован Конструкторский отдел, призванный помогать разработчикам, и инженерам.

Конструкторский отдел помогает осуществить:

- Регистрацию проекта у производителя компонентов.
- Техническую поддержку проекта.
- Защиту от снятия компонента с производства.
- Оценку стоимости проекта по компонентам.
- Изготовление тестовой платы монтаж и пусконаладочные работы.



Тел: +7 (812) 336 43 04 (многоканальный)

Email: [org@lifeelectronics.ru](mailto:org@lifeelectronics.ru)