

NPH Series

Solid State Low Pressure Sensors



Applications

- Process control, P-to-I converters
- Pneumatic control systems
- HVAC controls
- Biomedical: Infusion pumps, sphygmomanometers, respirators
- Aerospace: Altimeters, barometers, cabin pressure sensors
- Computer peripherals

Features

- Solid state, high reliability
- Standard TO-8 package suitable for PC board mount
- Low cost , small size
- Available in gauge, absolute, and differential pressure versions
- Media compatible with non-corrosive gases and dry air
- Thermal accuracy FSO 0.5% typical
- Overpressure capability to five times maximum rated pressure
- Three standard ranges: 0 to 10 inH₂O (0 to 25 mbar), 0 to 1 psi (0 to 0.06 bar), and 0 to 5 psi (0 to 0.34 bar)
- Nonlinearity 0.05% FSO typical
- Standard 3/16 in OD pressure port
- Ceramic substrate with temperature compensation resistors

NPH Series Specifications

Description

An integrated circuit silicon sensor chip is housed in a standard TO-8 electrical package that is printed circuit board mountable.

The latest techniques in micromachining have been used to ion-implant piezoresistive strain gauges into a wheatstone bridge configuration that is integrally formed on a micromachined silicon diaphragm. As with all NovaSensor silicon sensors, the NPH Series employs SenStable® processing technology, providing excellent output stability. Constant current excitation to the sensor produces a voltage output that is linearly proportional to the input pressure.

The user can provide standard signal conditioning circuitry to amplify the 100 mV output signal. The sensor is compatible with most non-corrosive gases and dry air.

A laser-trimmed, thick-film resistor network on a hybrid ceramic substrate provides temperature compensation.

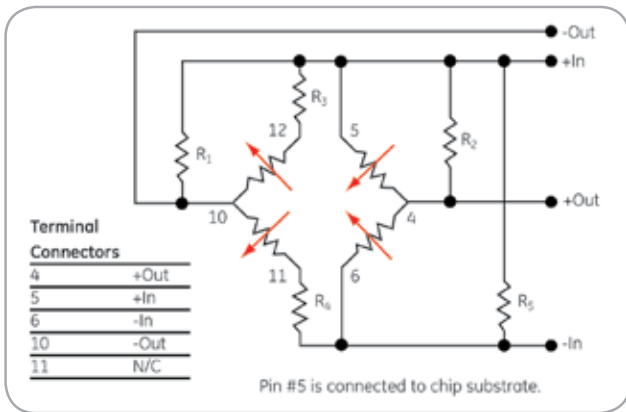

NPH Series schematic diagram

Parameter	Value	Units	Notes
General			
Pressure Range	0 to 10	inH ₂ O	(0 to 25 mbar) 0 to 2.5 kPa
	0 to 1	psi	(0 to 7 bar) 0 to 7 kPa
	0 to 5	psi	(0 to 0.34 bar) 0 to 30 kPa
Maximum Pressure	5x		rated pressure ⁽¹⁰⁾
Electrical @ 77°F (25°C) Unless Otherwise Stated			
Input Excitation	1.5	mA	2 mA maximum
Insulation Resistance	100	MΩ	@ 50 VDC
Input Impedance	3200	Ω	±25%
Output Impedance	5000	Ω	±20%
Bridge Impedance	5000	Ω	±20%
Environmental			
Temperature Range			
Operating ⁽⁹⁾	-40 to 257	°F	(-40°C to 125°C)
Compensated	32 to 158	°F	(0°C to 70°C)
Vibration	10	gRMS	20 to 2000Hz
Shock	100	g	11 milliseconds
Life (Dynamic Pressure Cycle)	1 x 10 ⁶	cycles	
Mechanical⁽¹¹⁾			
Weight	<0.2	oz	(<5 g)
Media Compatibility	Non-corrosive gases and clean, dry air		
Wetted Materials			
Top Port	Nickel, gold plated Kovar, silicone gel, gold wire, RTV, silicon and glass.		
Bottom Port	Gold plated Kovar, silicon, glass and RTV ⁽⁹⁾		

Parameter	Min.	Typical 2.5 kPa	Max.	Min.	Typical 7 & 30 kPa	Max.	Units	Notes
Performance Parameters(7), Compensated(1)								
Offset	-8	2	8	-4	2	4	mV	
Full Scale (FS) Output								
2.5 kPa	25	50	90				mV	2
7 kPa				50	75	150	mV	2
30 kPa				75	100	125	mV	2
Linearity	-1.0	0.1	1.0	-0.25	0.05	0.25	%FSO	3
Hysteresis & Repeatability	-0.2	0.05	0.2	-0.2	0.05	0.2	%FSO	
Thermal								
Accuracy of Offset	-3	0.5	3	-2	0.5	2	%FSO	4
Accuracy of FSO	-3	-1	3	-1.5	-0.5	1.5	%FSO	4
Thermal Hysteresis	-0.75	0.5	0.75	-0.5	0.2	0.5	%FSO	5
Short-Term Stability of Offset		5			5		μV/V	6, 11
Short-Term Stability of FSO		5			5		μV/V	6, 11

1. Performance with offset, thermal accuracy of offset, and thermal accuracy of FSO compensation resistors.
2. FSO with 1.5mA input excitation.
3. Best fit straight line.
4. 32°F to 158°F (0°C to 70°C) with reference to 77°F (25°C)
5. 32°F to 158°F (0°C to 70°C), by design
6. Normalized offset/bridge voltage -100 hrs, typical value, not tested in production.
7. All values measured at 77°F (25°C) and at 1.5 mA, unless otherwise noted.
8. Reduced performance outside compensation range.
9. Backside differential tube is nickel or Kovar.
10. Top side pressure.
11. Typical specifications are for reference only; absolute values may vary.

NPH Series Specifications

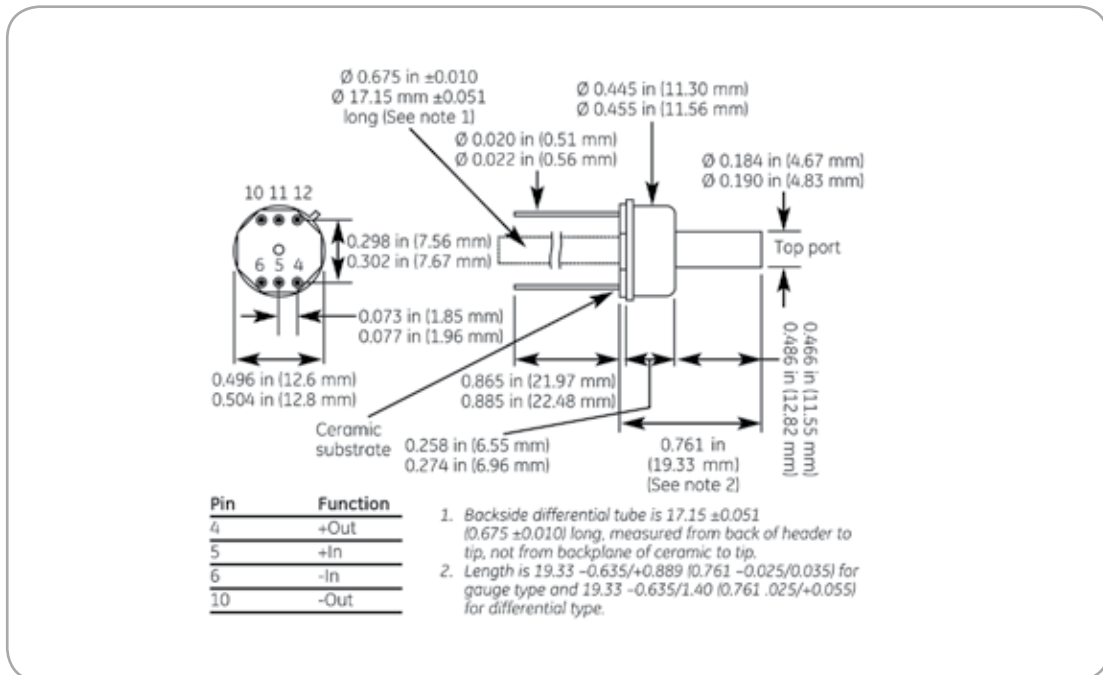

NPH Series package diagram

Ordering Information

The code number to be ordered may be specified as follows:

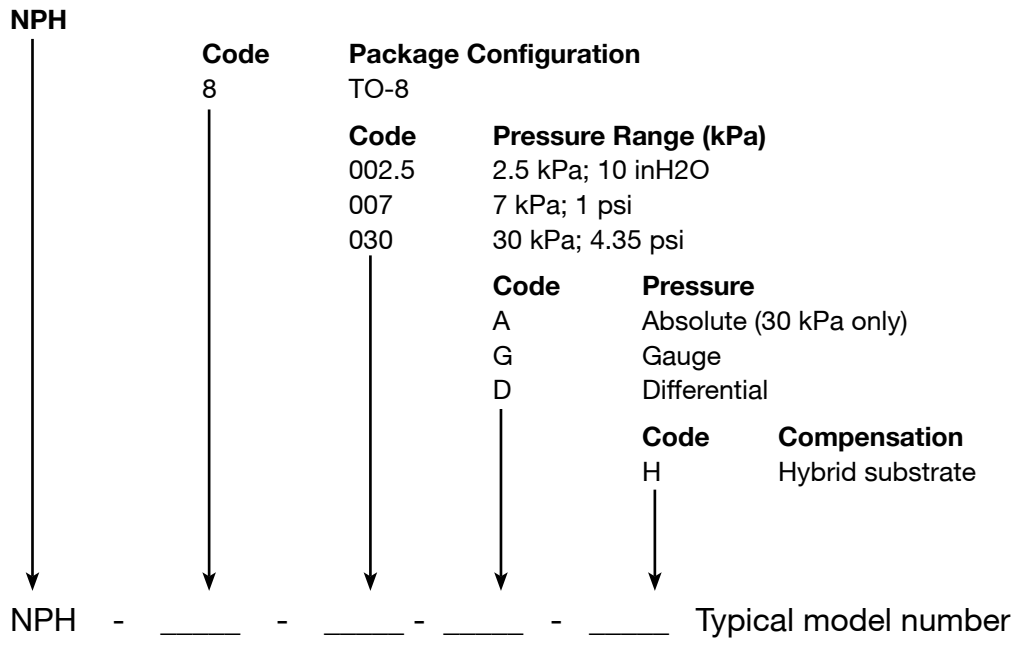

Amphenol

Advanced Sensors

www.amphenol-sensors.com

© 2014 Amphenol Corporation. All Rights Reserved. Specifications are subject to change without notice.
Other company names and product names used in this document are the registered trademarks or
trademarks of their respective owners.

AAS-920-275B-08/2014

Mouser Electronics

Authorized Distributor

Click to View Pricing, Inventory, Delivery & Lifecycle Information:

Amphenol:

[NPH-8-002.5DH](#) [NPH-8-002.5GH](#) [NPH-8-007GH](#) [NPH-8-007DH](#) [NPH-8-030AH](#) [NPH-8-030GH](#) [NPH-8-030DH](#)
[NPH-8-172DH](#)

Компания «Life Electronics» занимается поставками электронных компонентов импортного и отечественного производства от производителей и со складов крупных дистрибьюторов Европы, Америки и Азии.

С конца 2013 года компания активно расширяет линейку поставок компонентов по направлению коаксиальный кабель, кварцевые генераторы и конденсаторы (керамические, пленочные, электролитические), за счёт заключения дистрибьюторских договоров

Мы предлагаем:

- Конкурентоспособные цены и скидки постоянным клиентам.
- Специальные условия для постоянных клиентов.
- Подбор аналогов.
- Поставку компонентов в любых объемах, удовлетворяющих вашим потребностям.
- Приемлемые сроки поставки, возможна ускоренная поставка.
- Доставку товара в любую точку России и стран СНГ.
- Комплексную поставку.
- Работу по проектам и поставку образцов.
- Формирование склада под заказчика.
- Сертификаты соответствия на поставляемую продукцию (по желанию клиента).
- Тестирование поставляемой продукции.
- Поставку компонентов, требующих военную и космическую приемку.
- Входной контроль качества.
- Наличие сертификата ISO.

В составе нашей компании организован Конструкторский отдел, призванный помогать разработчикам, и инженерам.

Конструкторский отдел помогает осуществить:

- Регистрацию проекта у производителя компонентов.
- Техническую поддержку проекта.
- Защиту от снятия компонента с производства.
- Оценку стоимости проекта по компонентам.
- Изготовление тестовой платы монтаж и пусконаладочные работы.



Тел: +7 (812) 336 43 04 (многоканальный)
Email: org@lifeelectronics.ru