

REVISONS		DATE	DMN	APVD
C	RELEASE PER ECR-10-024107	8/31/2010	FL	SY
C1	RELEASE PER ECR-11-016951	7/20/2011	JJ	SY
D2	RELEASED PER ECR-16-011711	4/10/2017	A.X	H.W

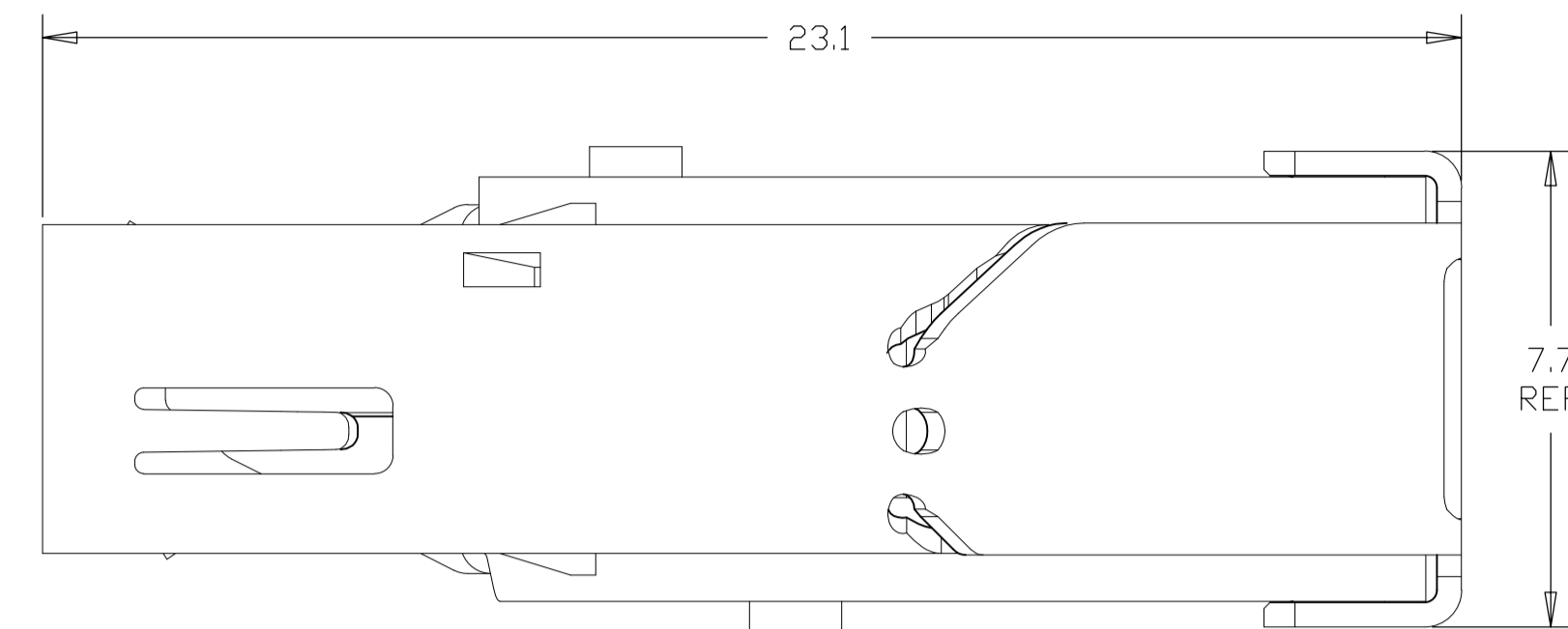

- 1 MATERIALS:
 HOUSING: HIGH TEMP THERMOPLASTIC, UL94V-0, BLACK, PBT.
 CONTACTS: COPPER ALLOY.
 SHIELD: STAINLESS STEEL.
- 2 FINISH:
 CONTACTS:
 MATING AREA: CONFORMS TO HDMI SPECIFICATION VERSION 1.3a TABLE 4-6 AND 4-7 (ELECTRICAL AND ENVIRONMENTAL PERFORMANCE), BASED ON EIA/ECA - 364-1000.01A (CONTROLLED ENVIRONMENT APPLICATIONS).
 SOLDER TAILS: TIN OVER NICKEL.
- 3 INTERFACE DIMENSIONS PER HDMI SPECIFICATION VERSION 1.3a.
- 4 WAVE SOLDER COMPATIBLE PER 109-202. CONDITION B. NO CLEAN FLUX IS RECOMMENDED.
- 5 THIS DIMENSION HAS AN ADDITIONAL 1.0 CLEARANCE OVER HDMI V1.3a SPECIFICATION MAXIMUM CABLE TYPE A PLUG HEIGHT.
- 6 REMOVE CAP IS RECOMMENDED AFTER WAVE SOLDER.
- 7 MATERIALS:
 HOUSING: HIGH TEMP THERMOPLASTIC, UL94V-0, BLACK, LCP.
 CONTACTS: COPPER ALLOY.
 SHIELD: STAINLESS STEEL.
- 8 STAND-OFF AREA.

2007435-1(-4)
 SCALE 6:1

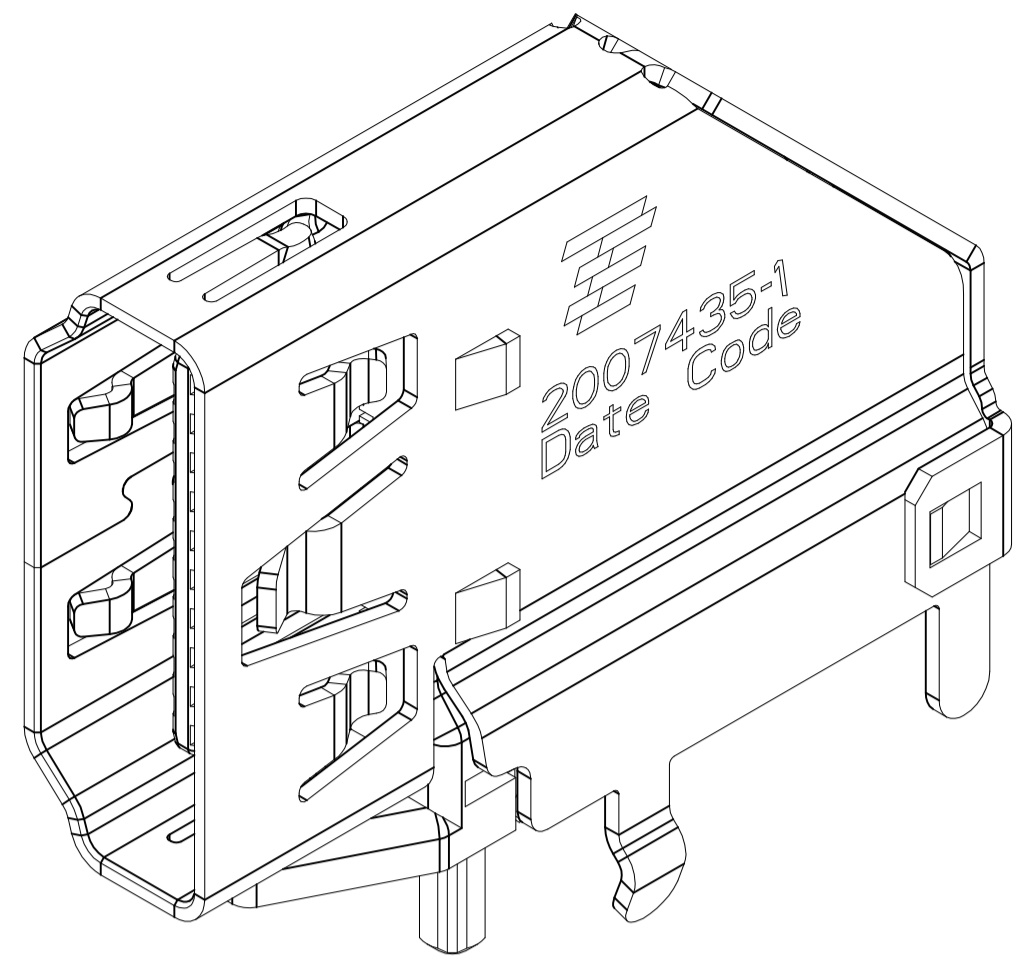
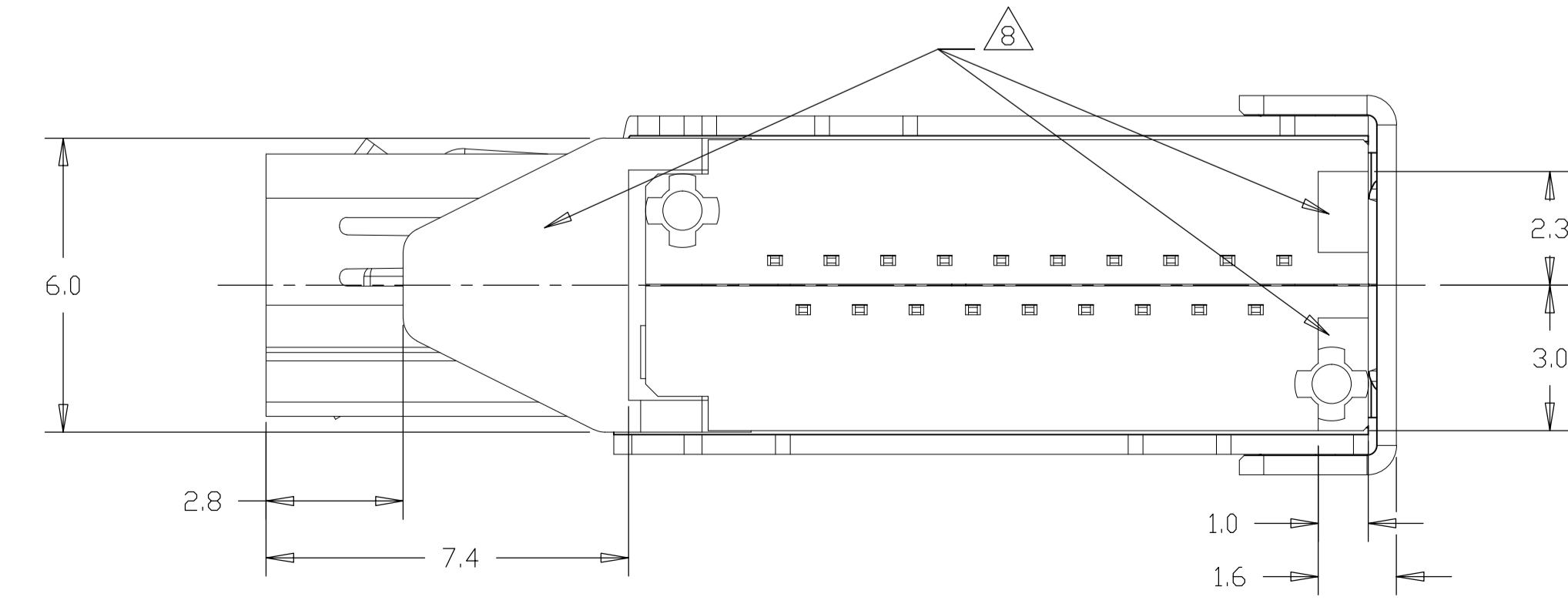
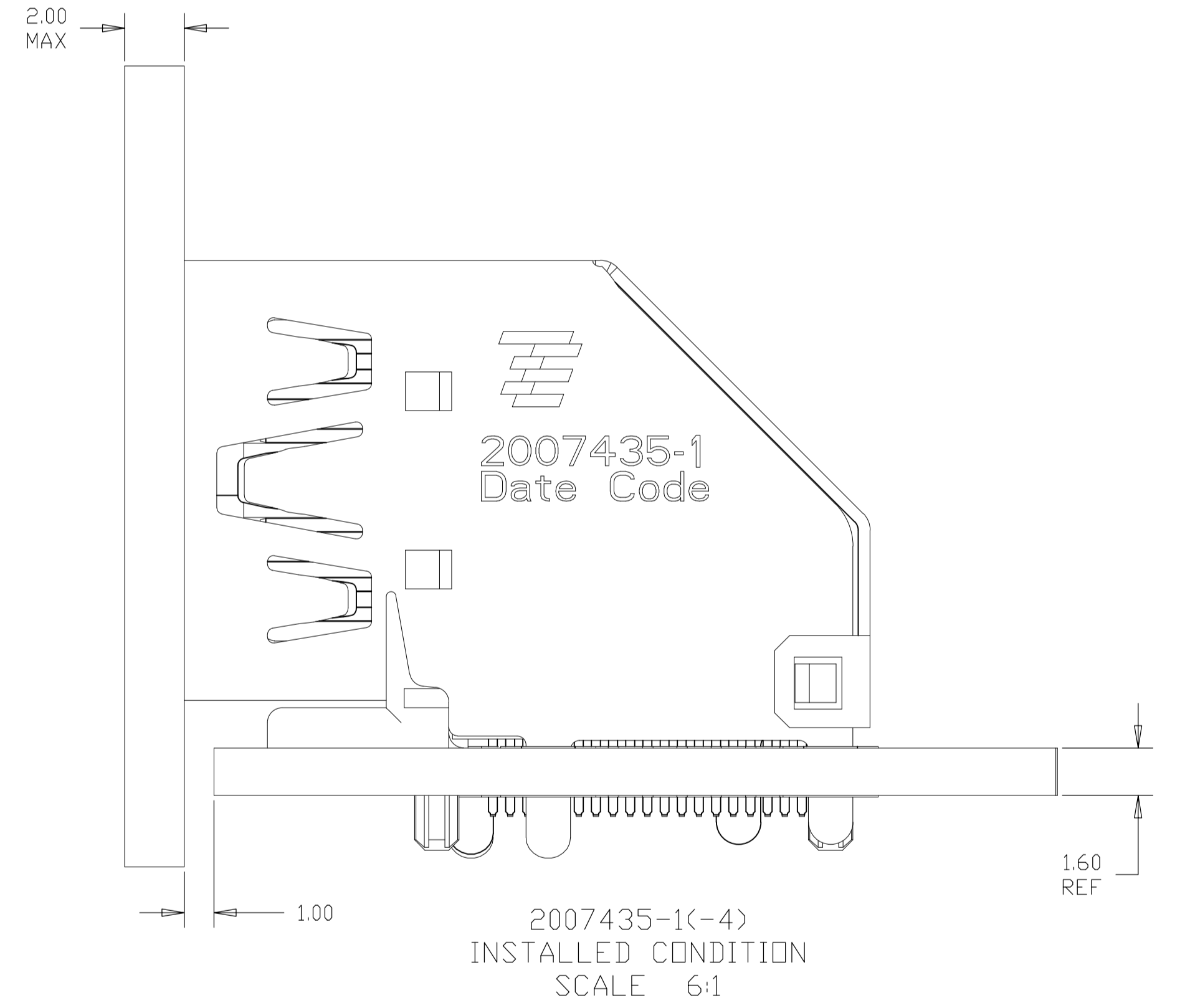
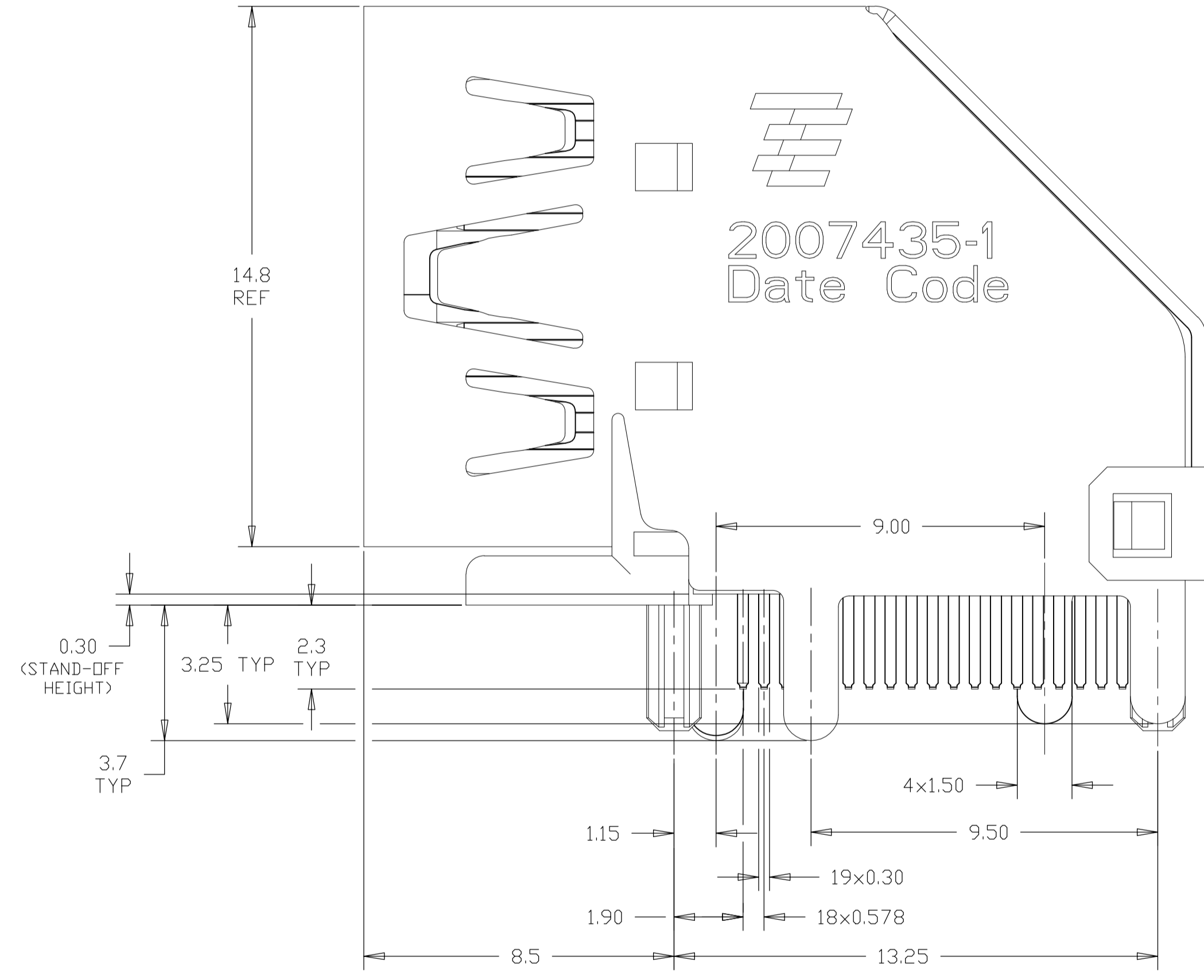
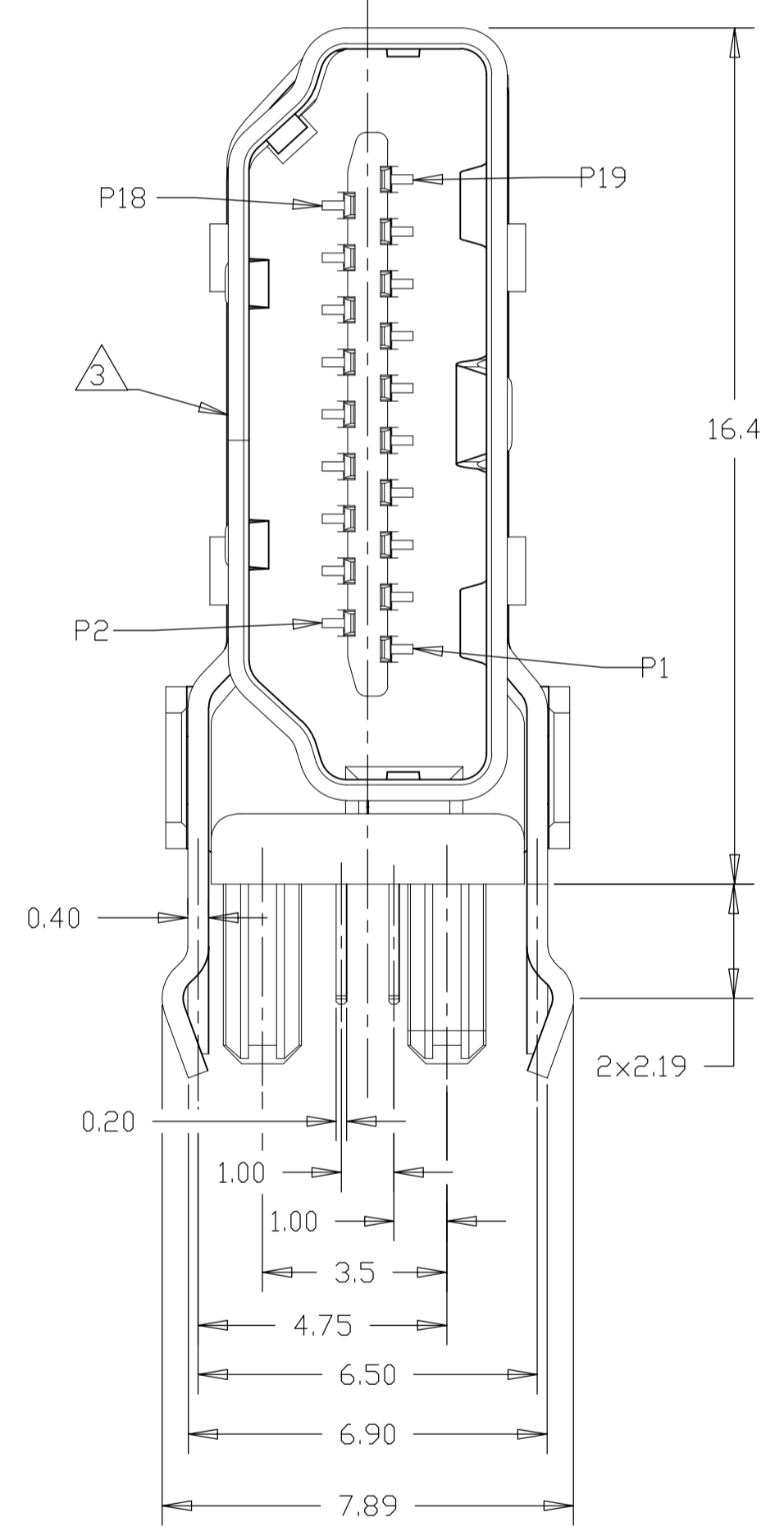

EMBOSS TAPE	WITHOUT POLYIMIDE TAPE	WITHOUT KINK AND WITH CAP	0.38 μm	△	2.00	2007435-7
EMBOSS TAPE	WITH POLYIMIDE TAPE	WITHOUT KINK AND WITHOUT CAP	0.38 μm	△	2.00	2007435-6
TRAY	WITHOUT POLYIMIDE TAPE	WITH KINK AND WITH CAP	0.38 μm	△	1.60	2007435-5
		WITH KINK AND WITHOUT CAP	0.76 μm	△	1.60	2007435-4
		WITHOUT KINK AND WITH CAP	0.38 μm	△	1.60	2007435-3
		WITHOUT KINK AND WITHOUT CAP	0.38 μm	△	2.40	2007435-2
PACKAGE		WITH KINK AND WITHOUT CAP	0.38 μm	△	1.60	2007435-1

THIS DRAWING IS A CONTROLLED DOCUMENT.

DMN Francis Lee 31AUG2010
 CHK Martin Li 31AUG2010
 APVD Steven Yao 31AUG2010

STE TE Connectivity

HDMI FLAG CONNECTOR ASSEMBLY

108-60079

SIZE A1 CAGE CODE 00779 DRAWING NO. 2007435

SCALE 8:1 SHEET 1 OF 10 REV D2

REVISONS		DATE	OWN	APPD
LOC	DIST	DESCRIPTION		
-	-	SEE SHEET 1	-	-

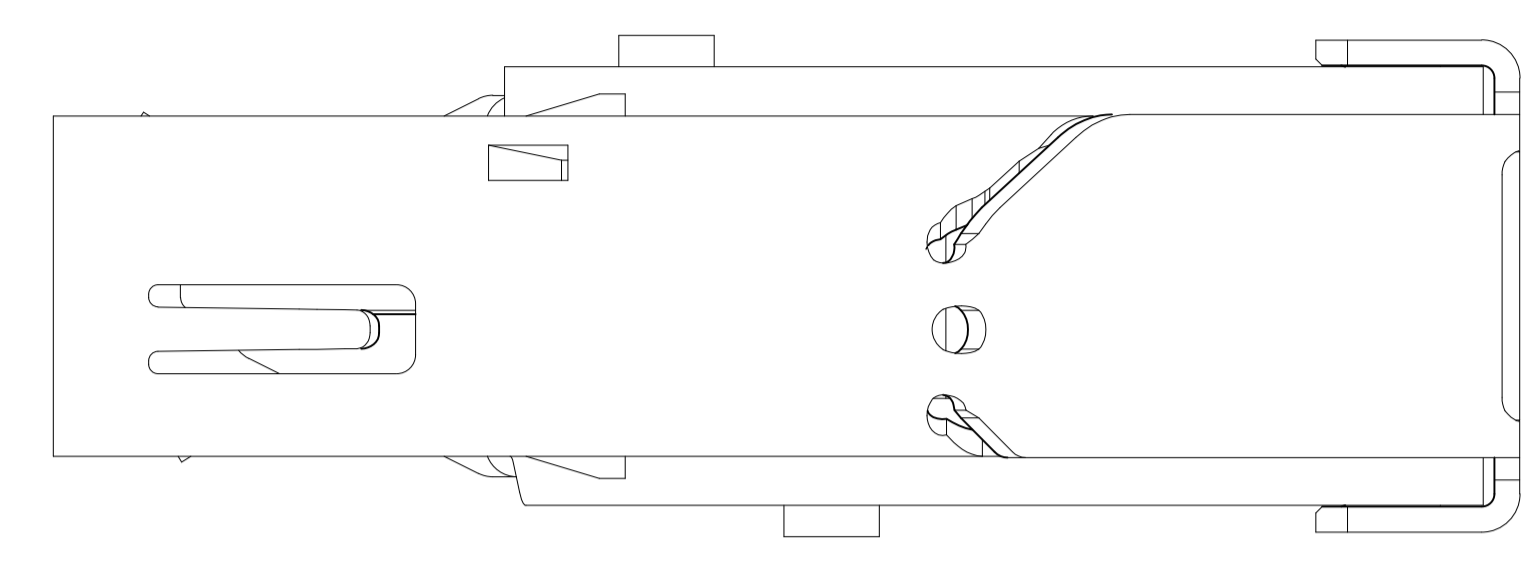
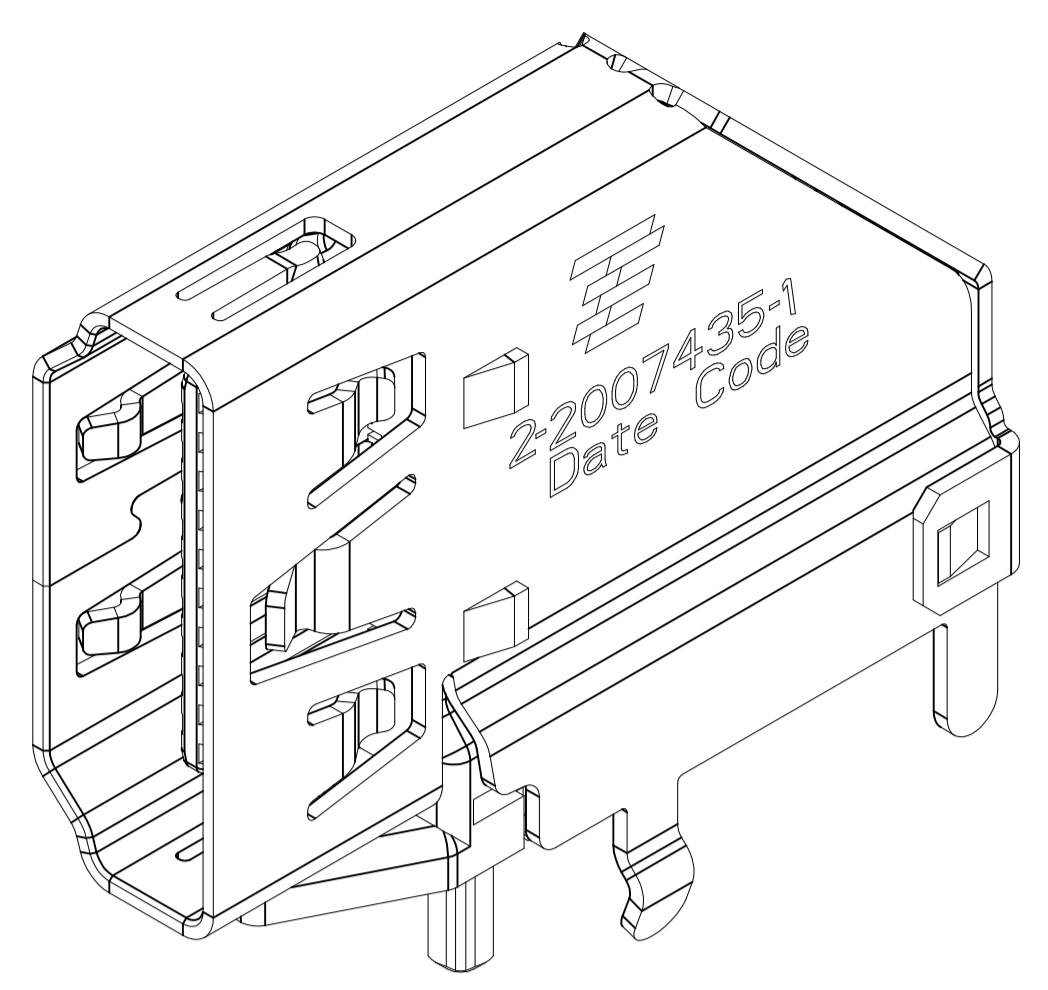

2-2007435-1 WITHOUT BOARD LOCK,
 UNMARKED DIMENSIONS SAME AS 2007435-1
 SCALE 6:1

- 1 MATERIALS:
 HOUSING: HIGH TEMP THERMOPLASTIC, UL94V-0, BLACK, PBT.
 CONTACTS: COPPER ALLOY.
 SHIELD: STAINLESS STEEL.
- 2 FINISH:
 CONTACTS:
 MATING AREA: CONFORMS TO HDMI SPECIFICATION VERSION 1.3a
 TABLE 4-6 AND 4-7 (ELECTRICAL AND ENVIRONMENTAL
 PERFORMANCE), BASED ON EIA/ECA - 364-1000.01A
 (CONTROLLED ENVIRONMENT APPLICATIONS).
 SOLDER TAILS: TIN OVER NICKEL.
- 3 INTERFACE DIMENSIONS PER HDMI SPECIFICATION VERSION 1.3a.
- 4 WAVE SOLDER COMPATIBLE PER 109-202. CONDITION B.
 NO CLEAN FLUX IS RECOMMENDED.
- 5 THIS DIMENSION HAS AN ADDITIONAL 1.0 CLEARANCE OVER
 HDMI V1.3a SPECIFICATION MAXIMUM CABLE TYPE A PLUG HEIGHT.
- 6 REMOVE CAP IS RECOMMENDED AFTER WAVE SOLDER.
- 7 MATERIALS:
 HOUSING: HIGH TEMP THERMOPLASTIC, UL94V-0, BLACK, LCP.
 CONTACTS: COPPER ALLOY.
 SHIELD: STAINLESS STEEL.
- 8 STAND-OFF AREA.

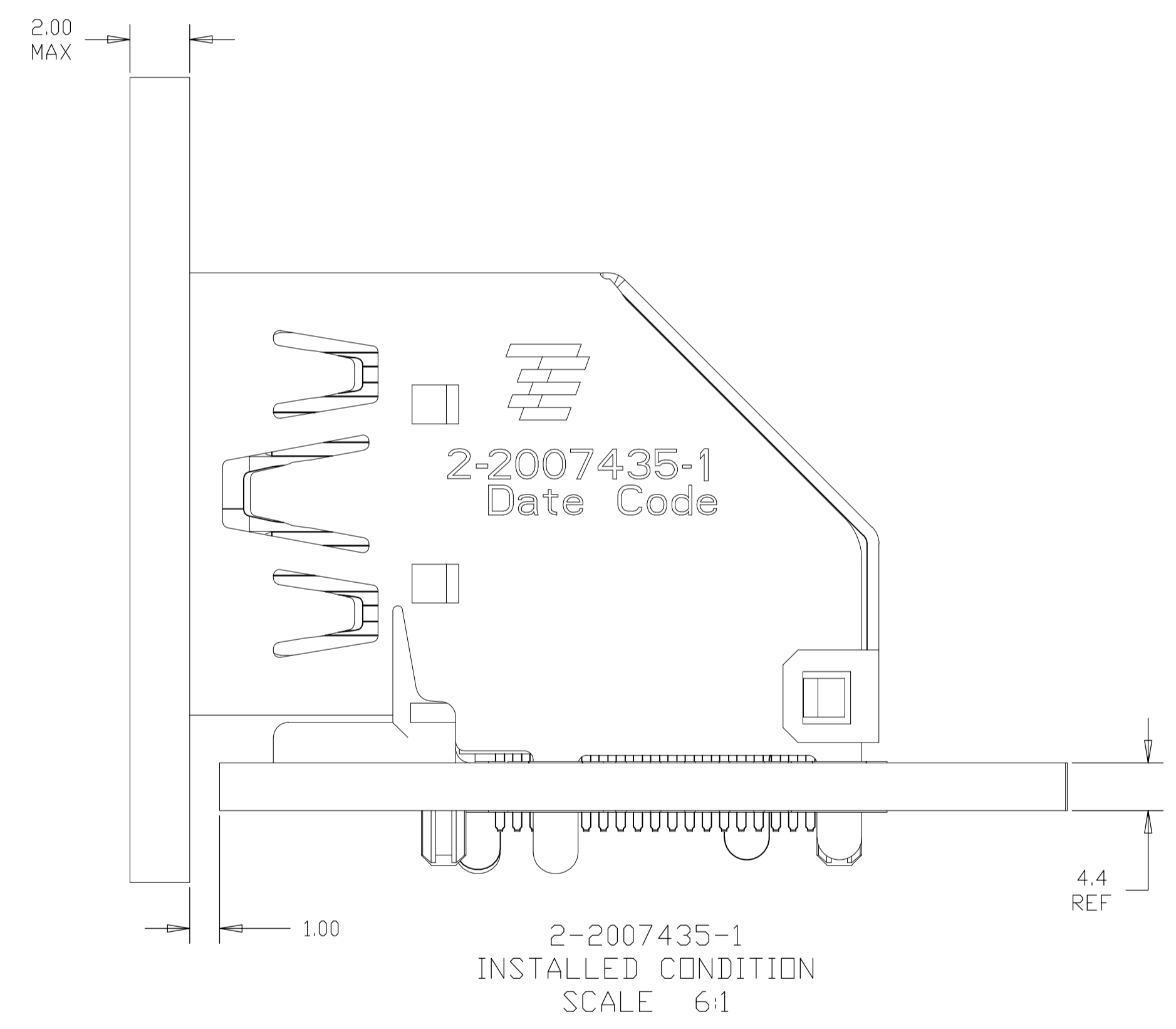
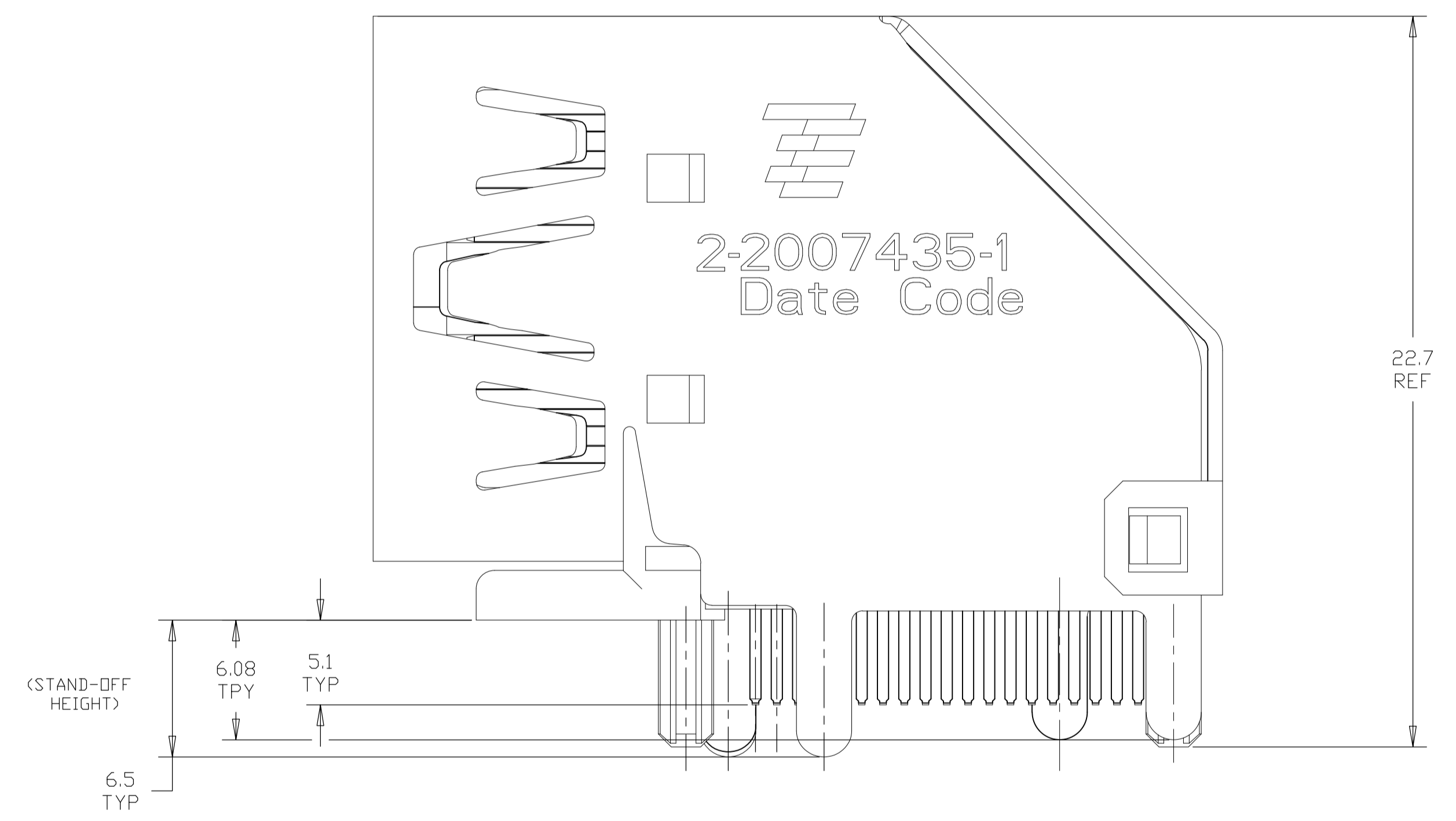
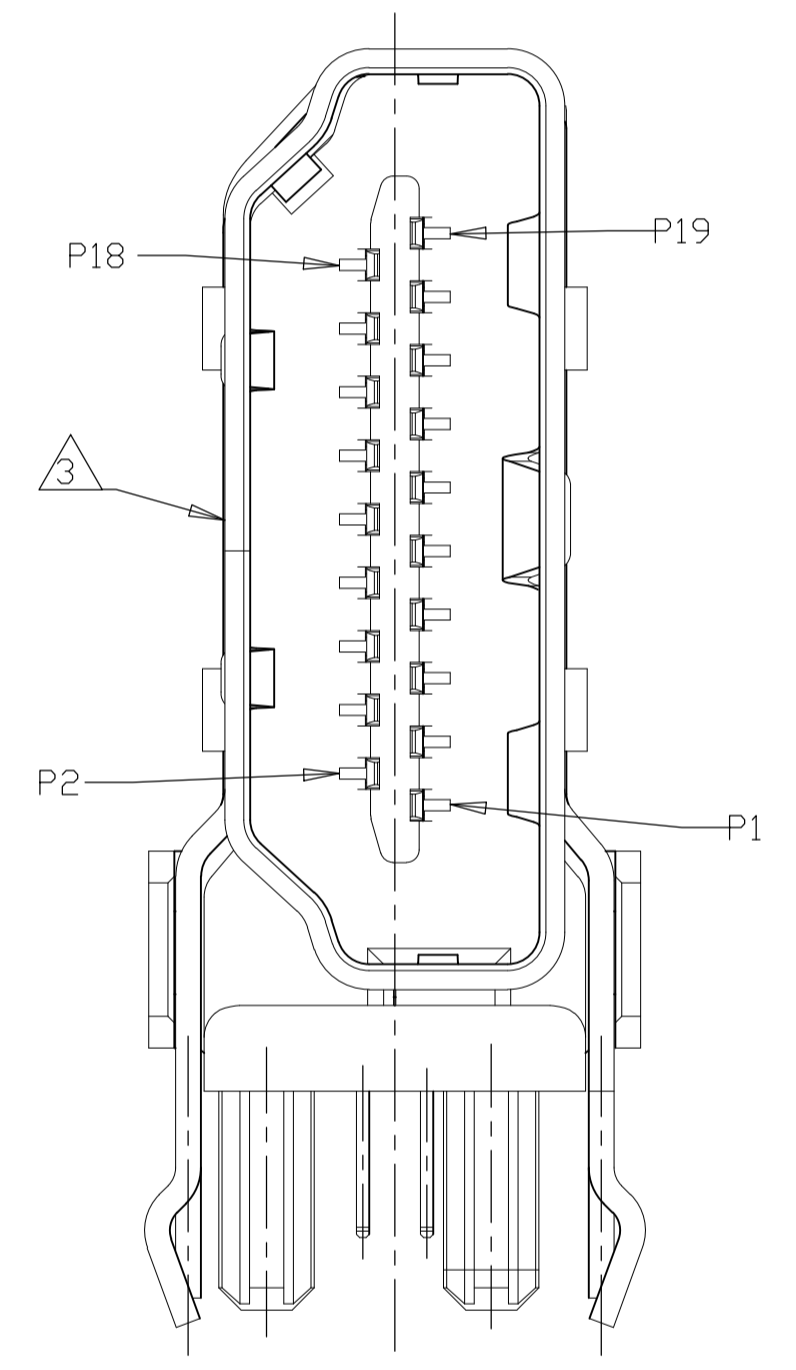

DESIGN APPROVED THIS PRINT IS
PRELIMINARY
 TO FIRST PIECE APPROVAL
 CONTACT PRODUCT ENGINEERING
 BEFORE USING THIS PRINT

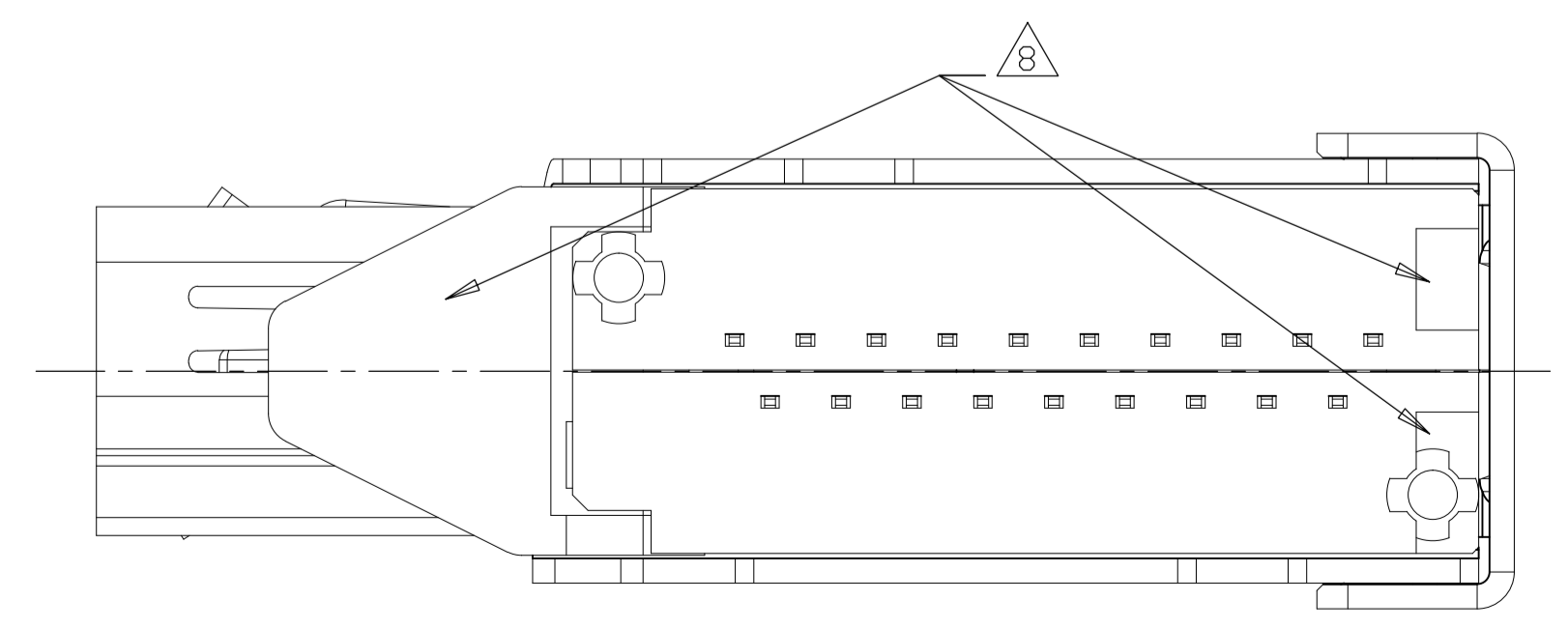

TRAY	WITHOUT POLYIMIDE TAPE	WITH KINK AND WITHOUT CAP	0.38 μ m	4.40	2-2007435-1
PACKAGE	REMARK		GOLD PLATING ON CONTACT AREA	MATERIAL	PCB THICKNESS
THIS DRAWING IS A CONTROLLED DOCUMENT.			DWN Francis Lee 31AUG2010	TE Connectivity	
DIMENSIONS: mm			Dsk Martin Li 31AUG2010	HDMI FLAG CONNECTOR ASSEMBLY	
TOLERANCES UNLESS OTHERWISE SPECIFIED:			APVD Steven Yao 31AUG2010	108-60079	
0 PLC \pm -			APPLICATION SPEC		
1 PLC \pm 0.3			SIZE CAGE CODE DRAWING NO		
2 PLC \pm 0.25			A1 00779 2007435		
3 PLC \pm 0.100			RESTRICTED TO		
4 PLC \pm 0.1000			CUSTOMER DRAWING		
ANGLES \pm 5			SCALE 8:1 SHEET 2 OF 10 REV D2		

LOC		DIST		REVISIONS			
P	LTR	DESCRIPTION	DATE	DN	APVD		
-	-	SEE SHEET 1	-	-	-	-	-

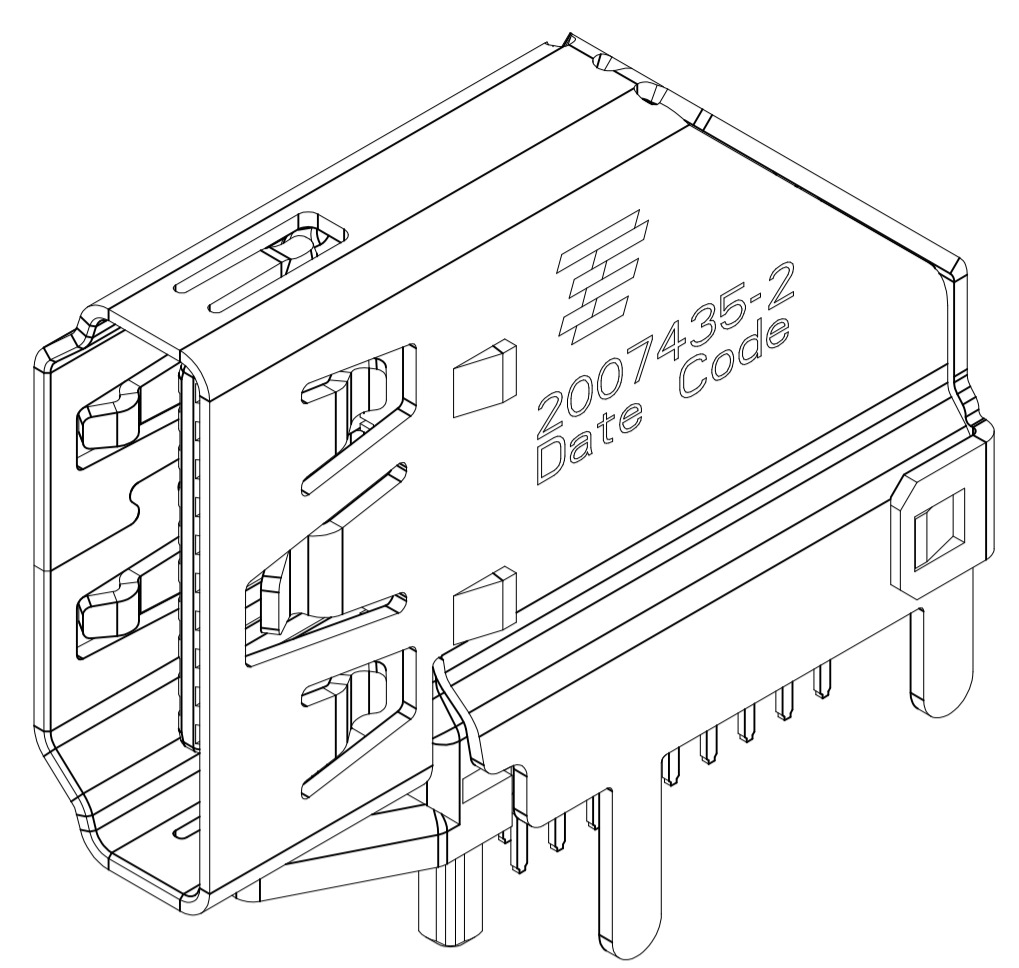

2007435-2 WITHOUT BOARD LOCK,
 UNMARKED DIMENSIONS SAME AS 2007435-1
 SCALE 6:1

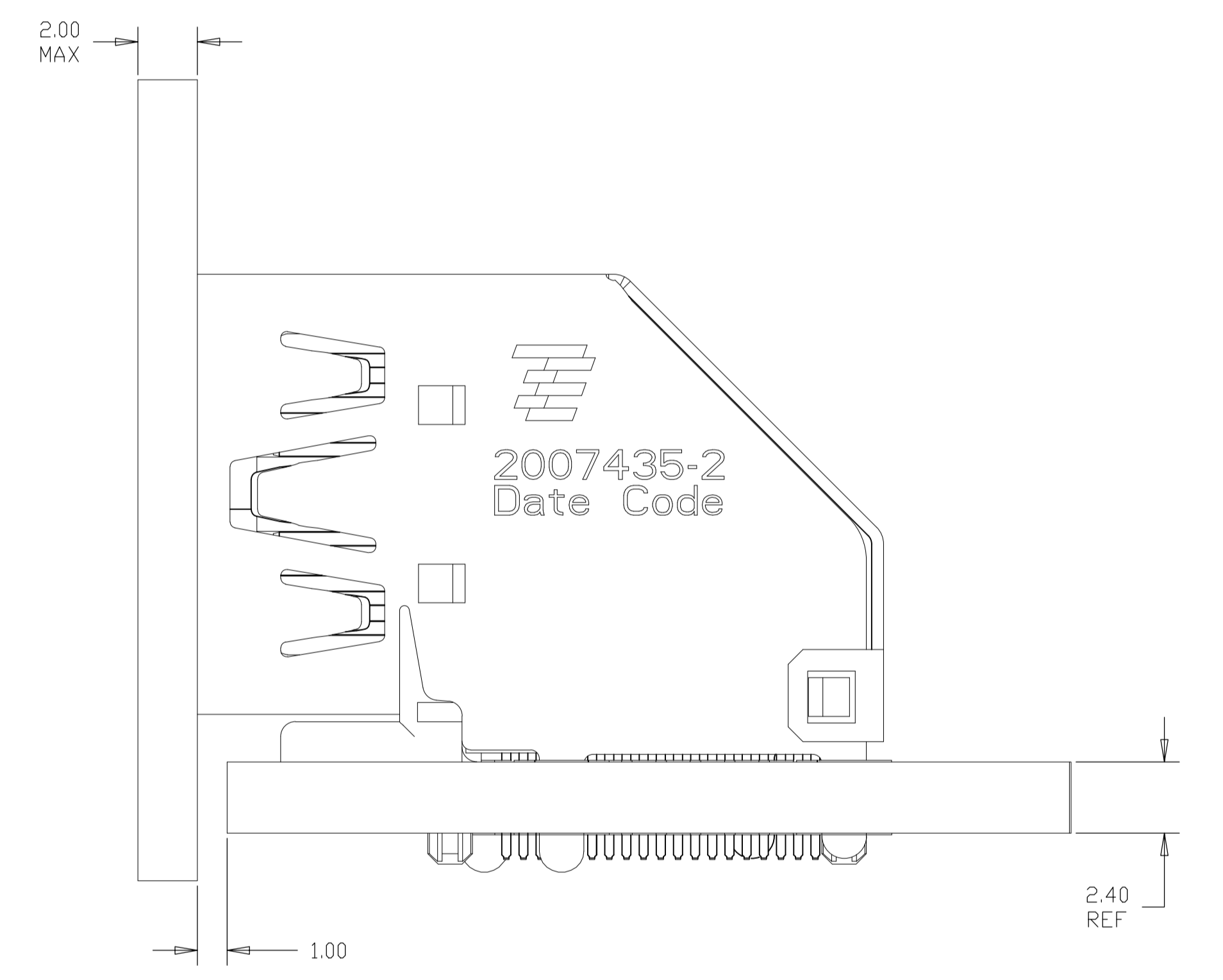
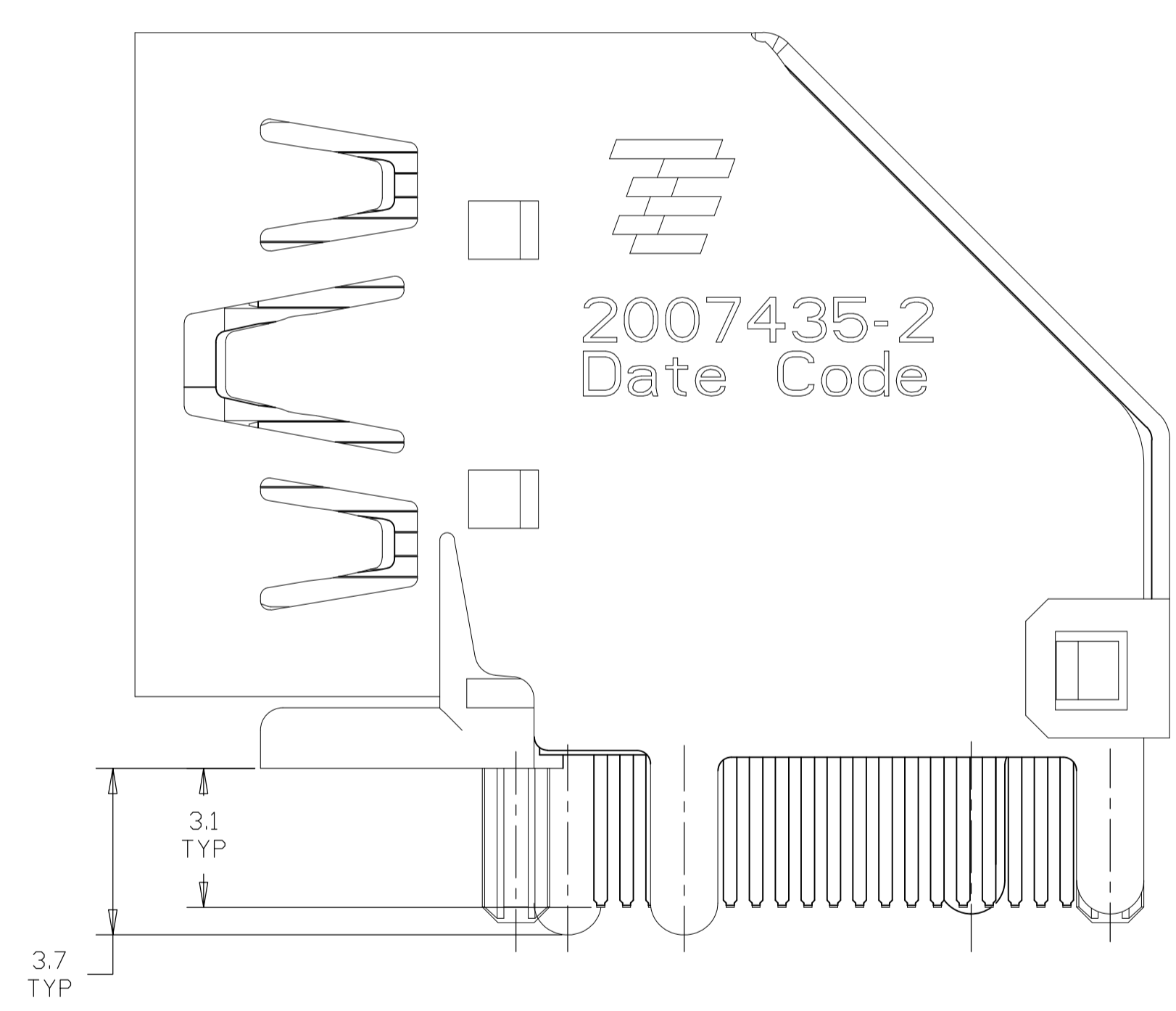
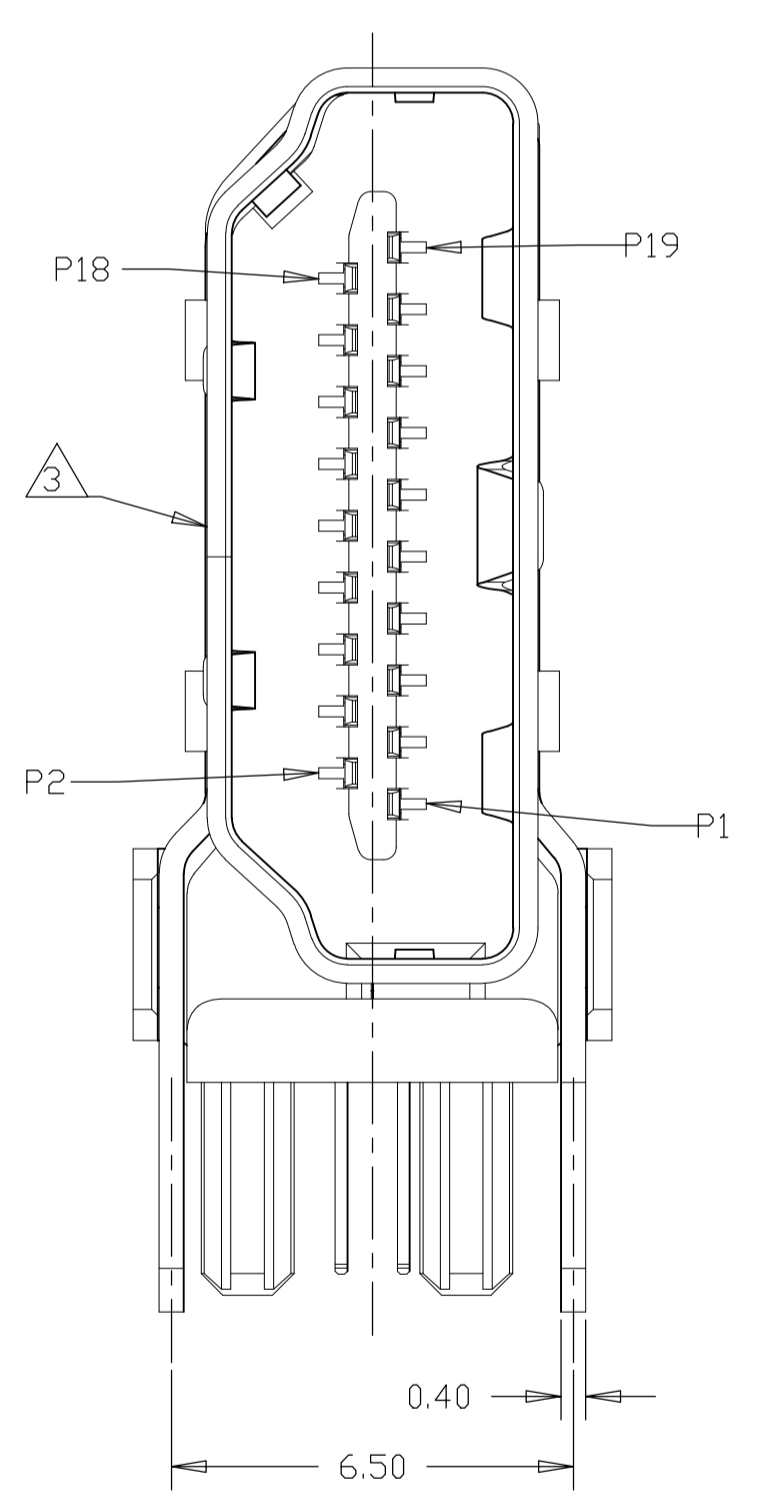
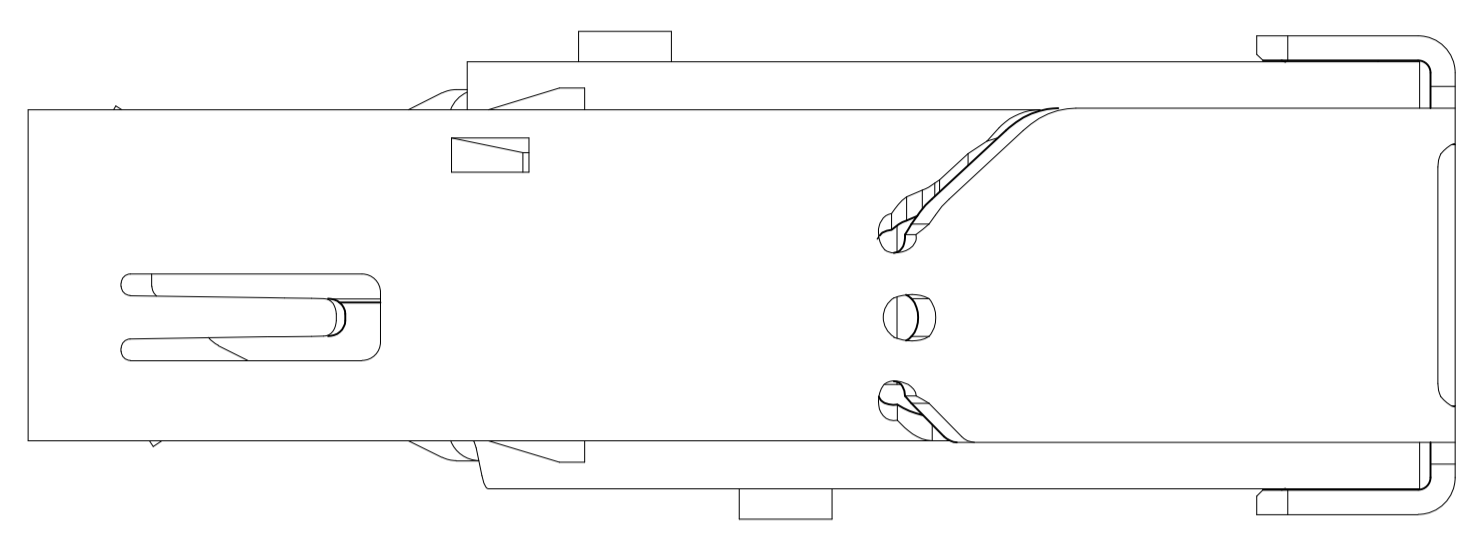

2007435-2
 INSTALLED CONDITION
 SCALE 6:1

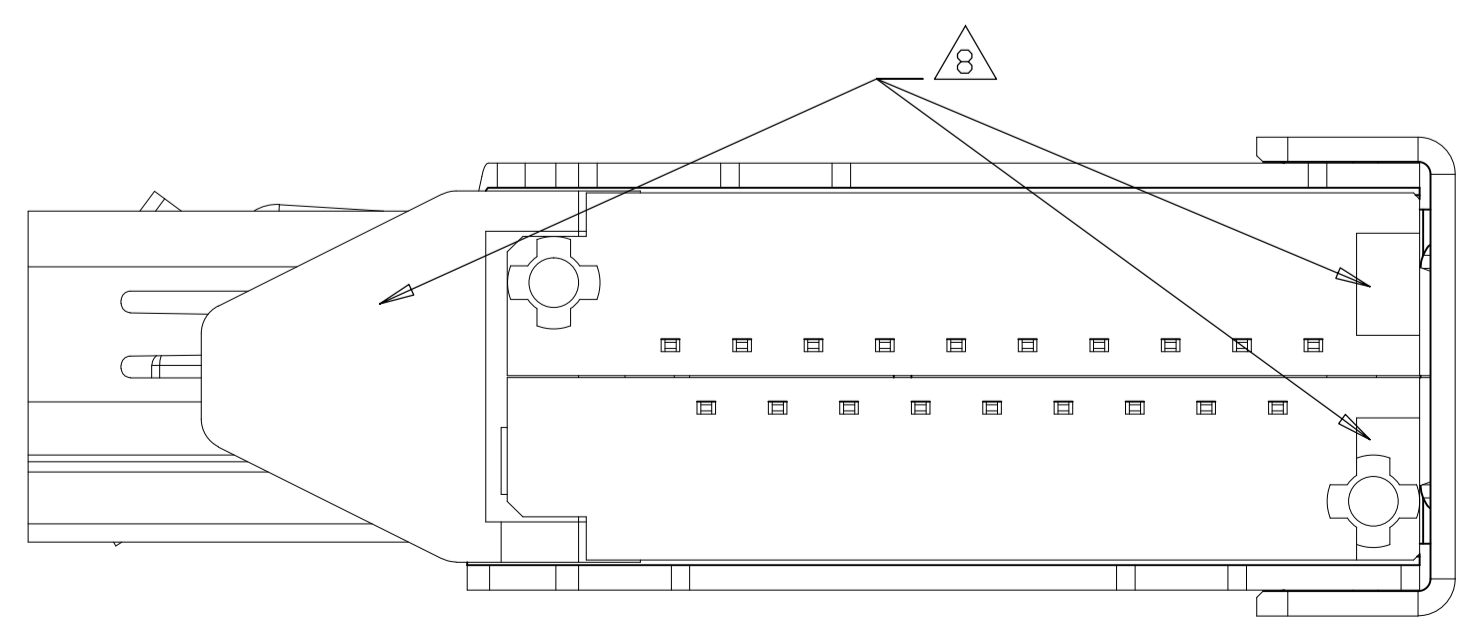

THIS DRAWING IS A CONTROLLED DOCUMENT.		DIN		TE Connectivity	
DIMENSIONS: mm		TOLERANCES UNLESS OTHERWISE SPECIFIED:		NAME	
<ul style="list-style-type: none"> 0. PLC ± - 1. PLC ± 0.3 2. PLC ± 0.25 3. PLC ± 0.100 4. PLC ± 0.1000 ANGLES ± - 		<ul style="list-style-type: none"> APVD PRODUCT SPEC APPLICATION SPEC 		HDMI FLAG CONNECTOR ASSEMBLY	
MATERIAL SEE TABLE		FINISH		SIZE CAGE CODE DRAWING NO	
				A1 00779 C=2007435	
		CUSTOMER DRAWING		SCALE 8:1 SHEET 3 OF 10 REV D2	

LOC		DIST		REVISIONS			
P	LTR	DESCRIPTION	DATE	DN	APVD		
-	-	SEE SHEET 1	-	-	-	-	-

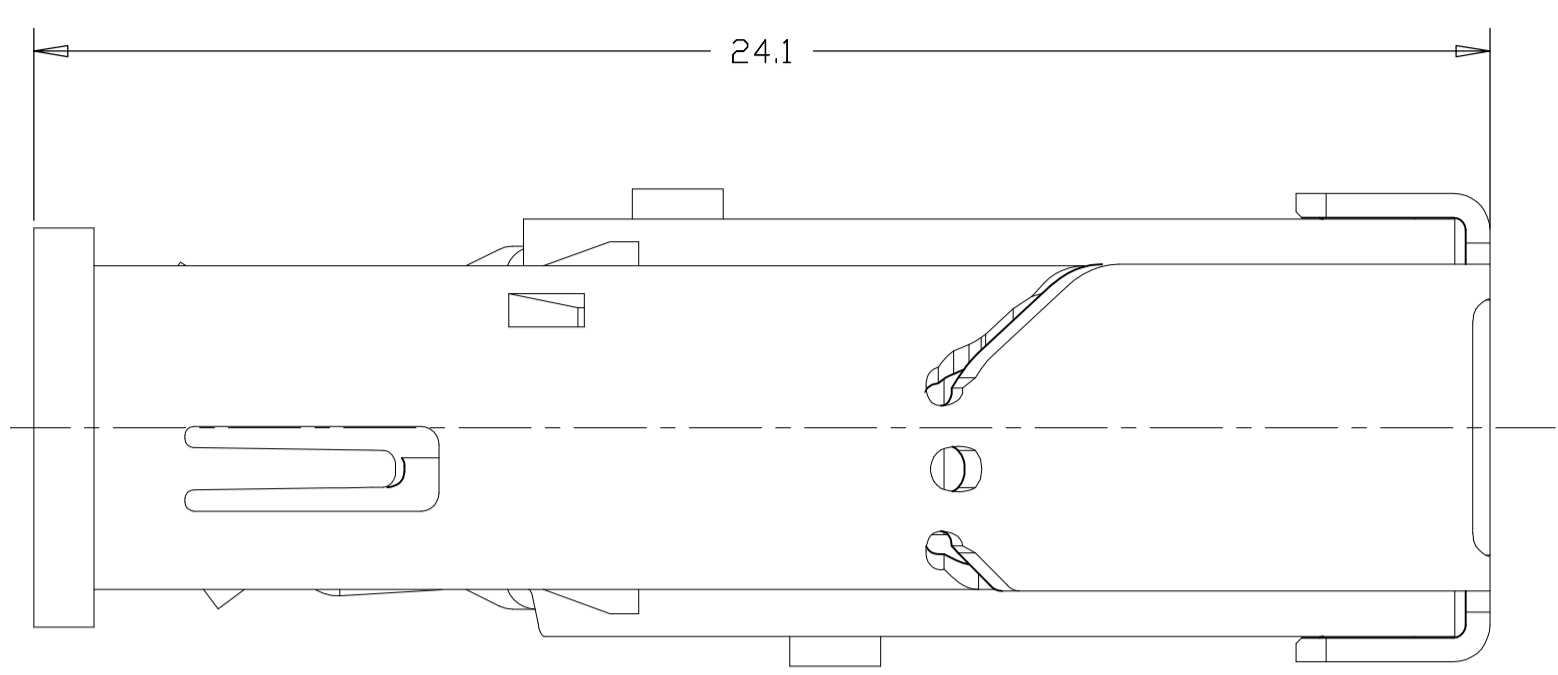
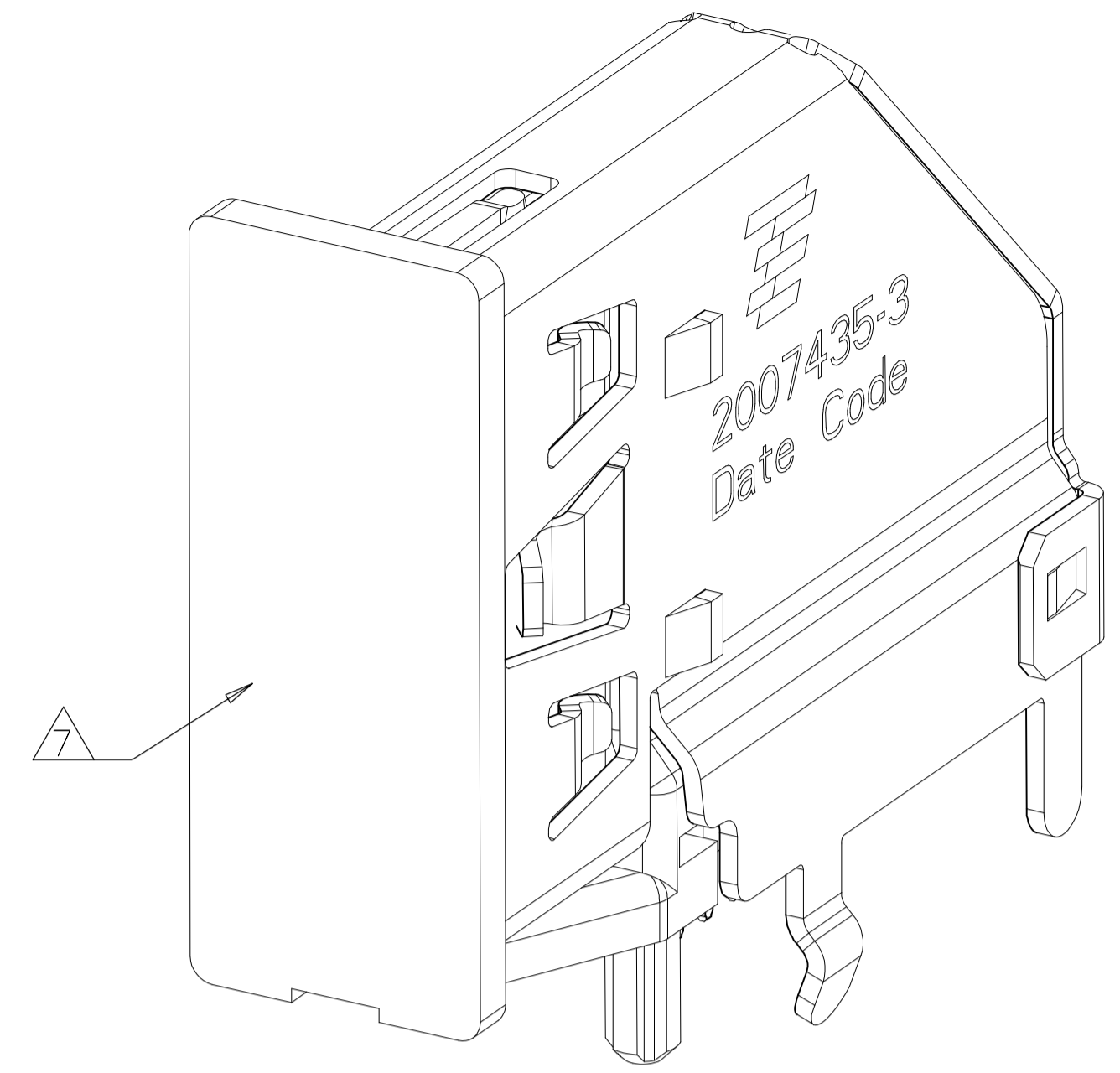

2007435-3(-5) WITH CAP, UNMARKED
 DIMENSIONS SAME AS 2007435-1
 SCALE 6:1

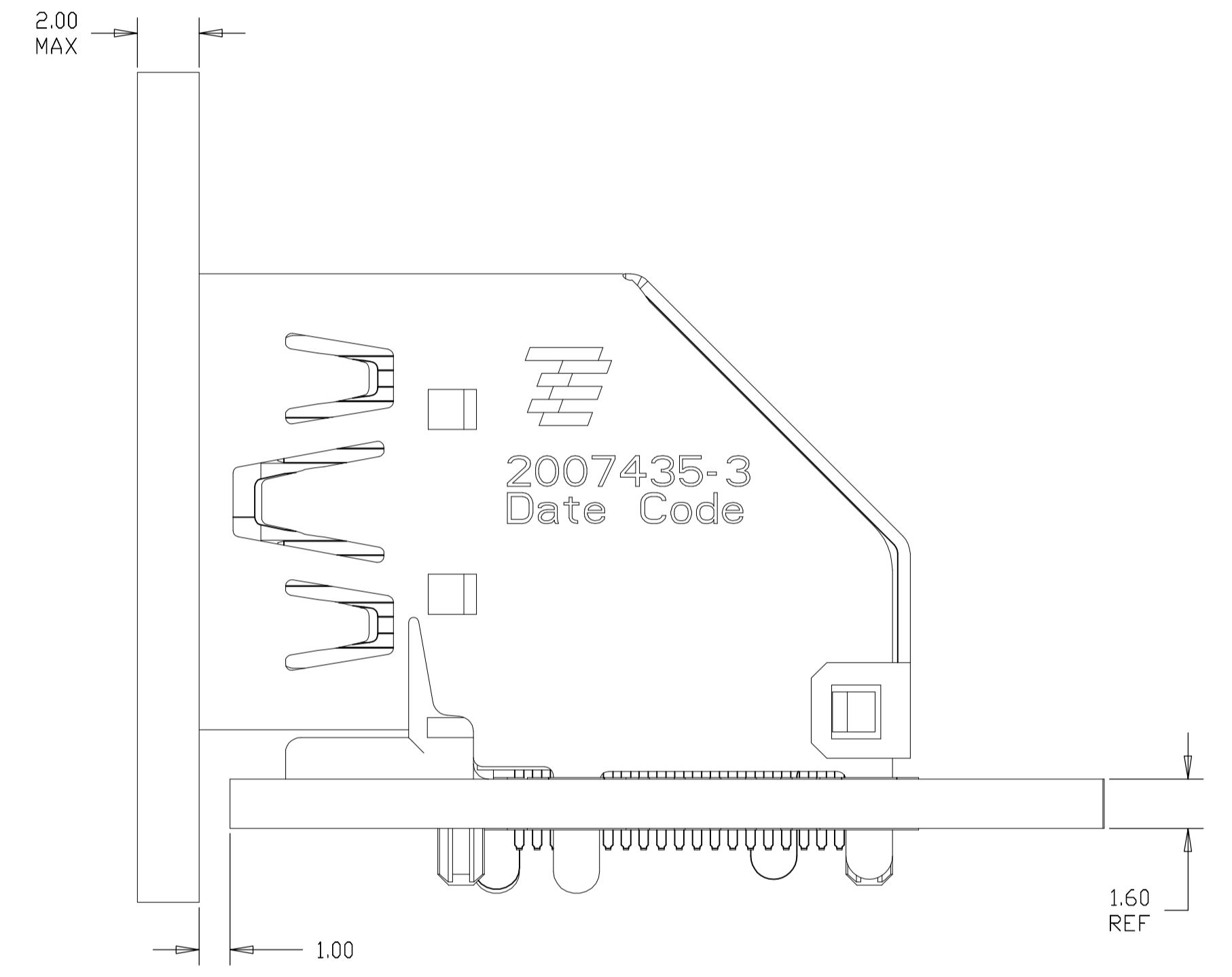
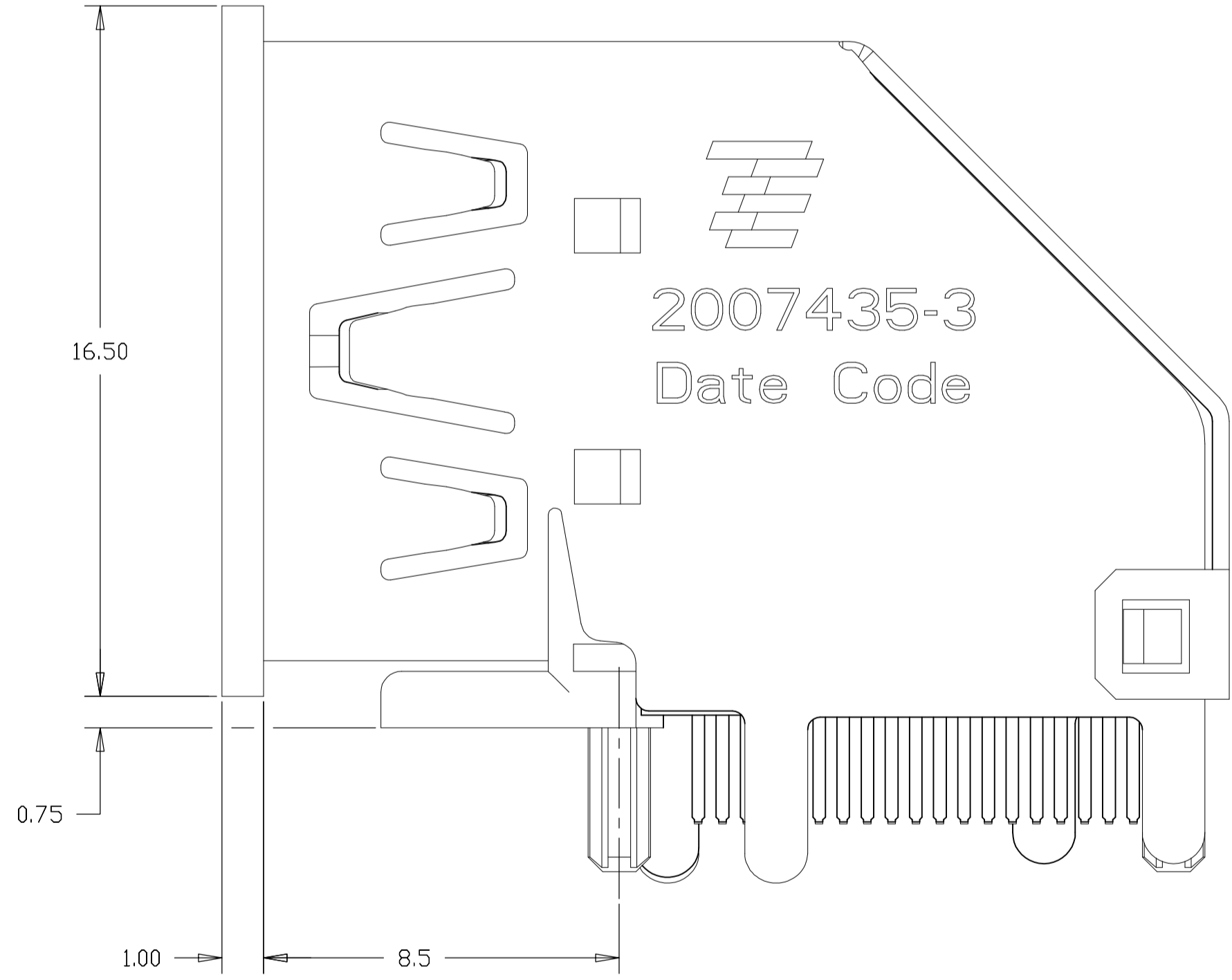
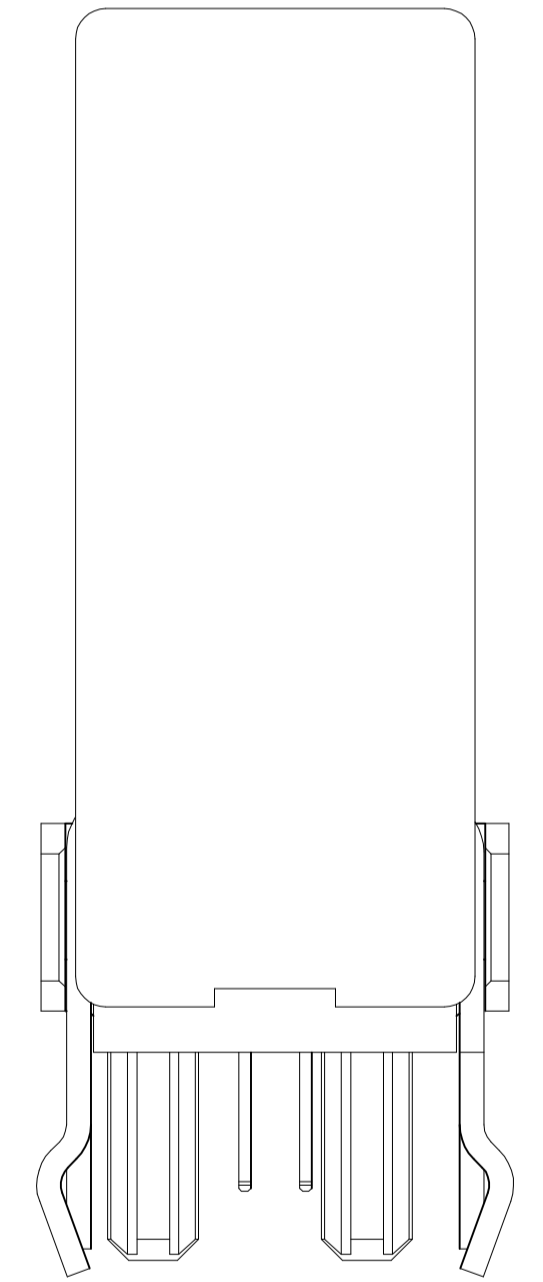

2007435-3(-5)
 INSTALLED CONDITION
 (ONLY FOR AFTER REMOVE CAP)
 SCALE 6:1

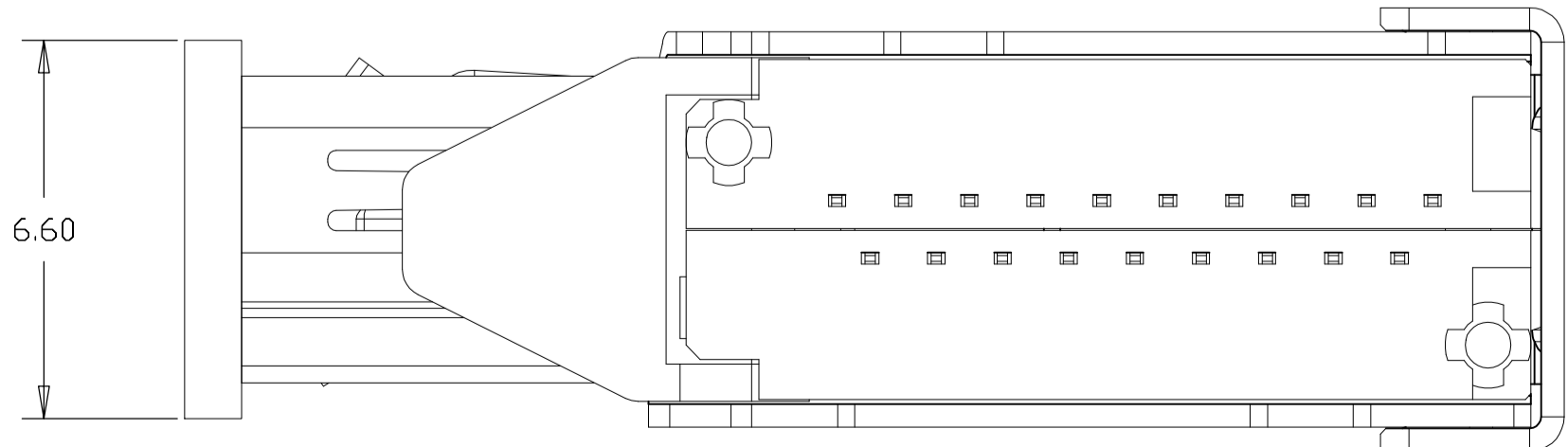

THIS DRAWING IS A CONTROLLED DOCUMENT.		DIN		TE Connectivity	
DIMENSIONS: mm		CHK			
TOLERANCES UNLESS OTHERWISE SPECIFIED: 0. PLC ± 0.3 1. PLC ± 0.25 2. PLC ± 0.10 3. PLC ± 0.10 4. PLC ± 0.10 ANGLES ± -		APVD		NAME	
		PRODUCT SPEC		HDMI FLAG CONNECTOR ASSEMBLY	
MATERIAL SEE TABLE		APPLICATION SPEC		RESTRICTED TO	
FINISH		WEIGHT		SIZE CAGE CODE DRAWING NO	
		CUSTOMER DRAWING		A1 00779 C=2007435	
		SCALE 8:1		SHEET 4 OF 10 REV D2	

LOC		DIST		REVISIONS			
P	LTR	DESCRIPTION	DATE	DN	APVD		
-	-	SEE SHEET 1	-	-	-	-	-

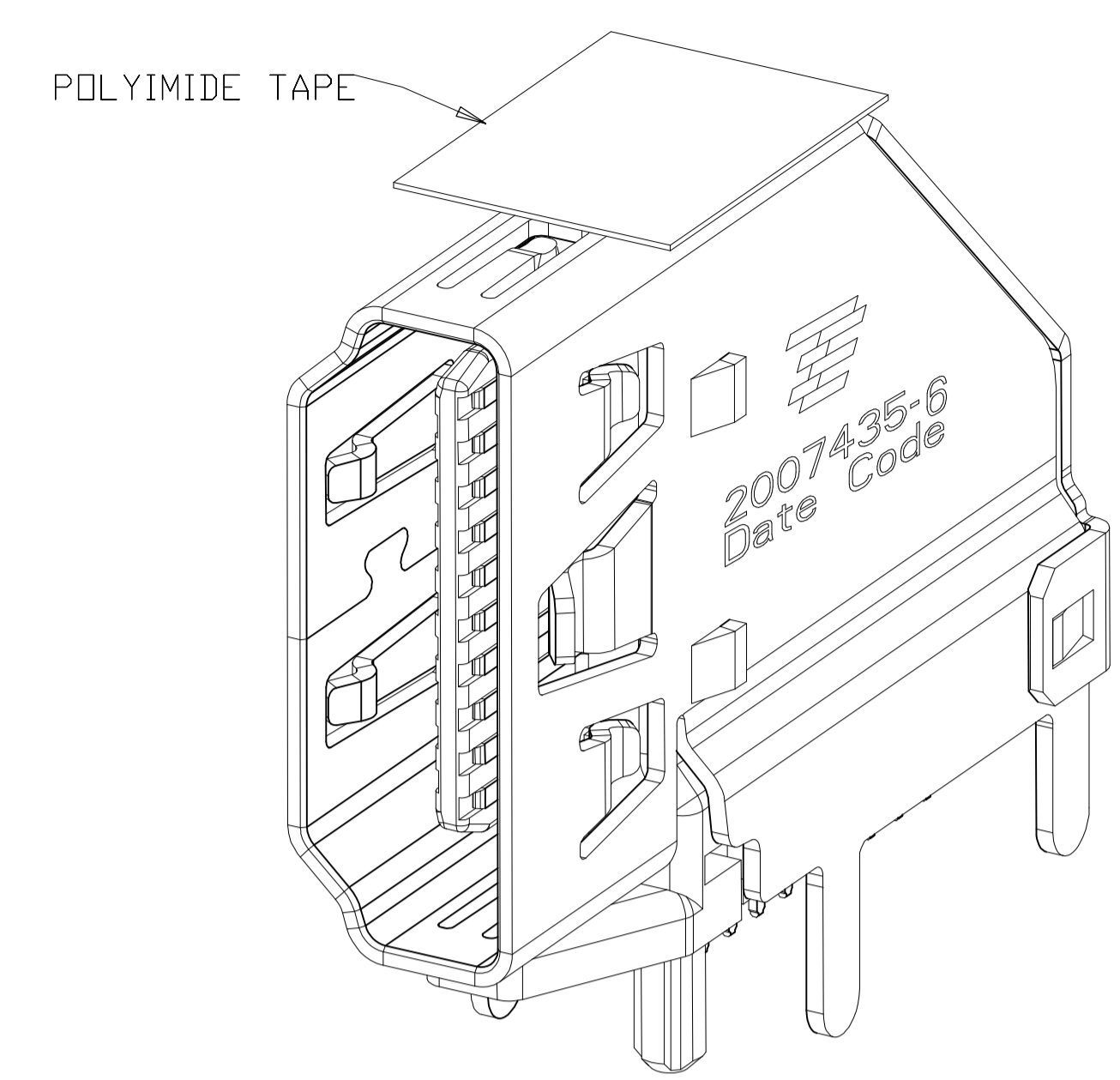
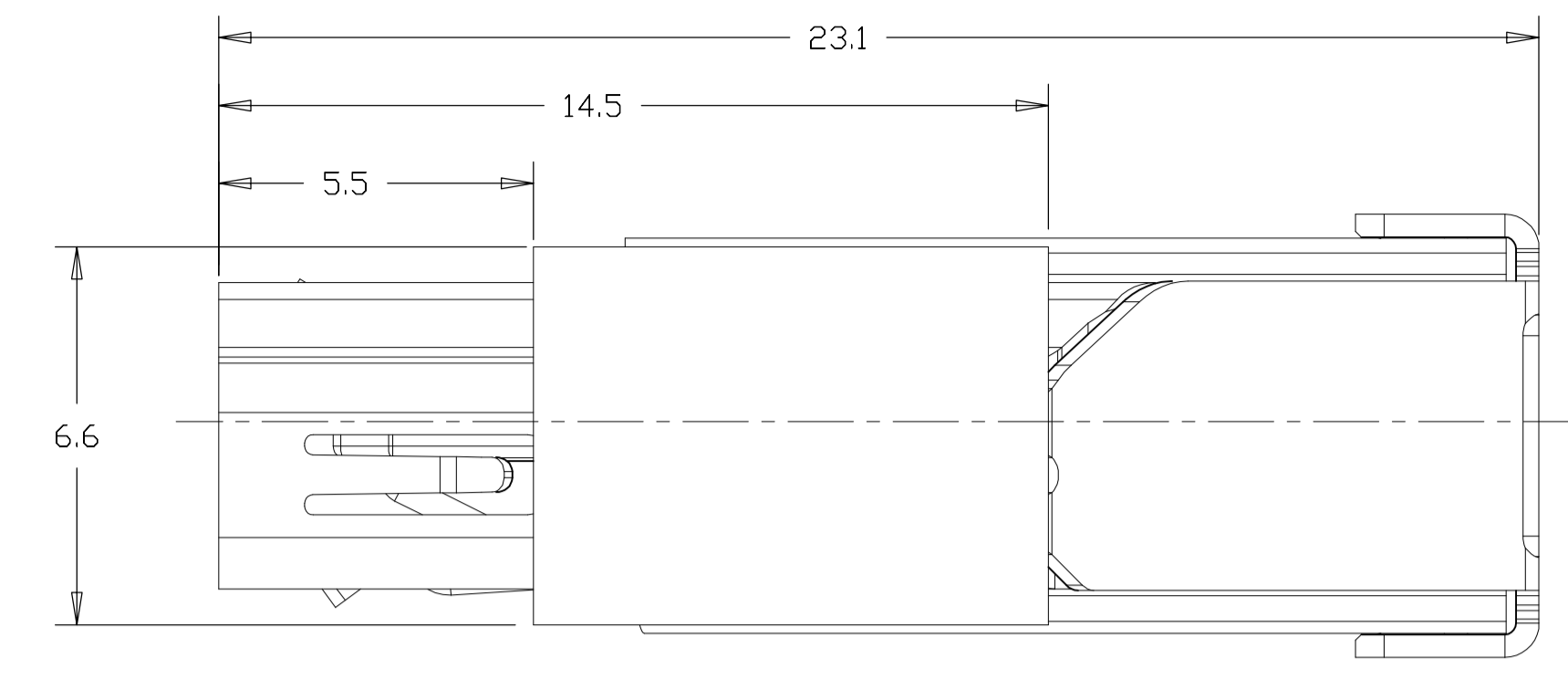

2007435-6 WITH POLYIMIDE TAPE,
UNMARKED DIMENSIONS SAME AS 2007435-1
SCALE 6:1

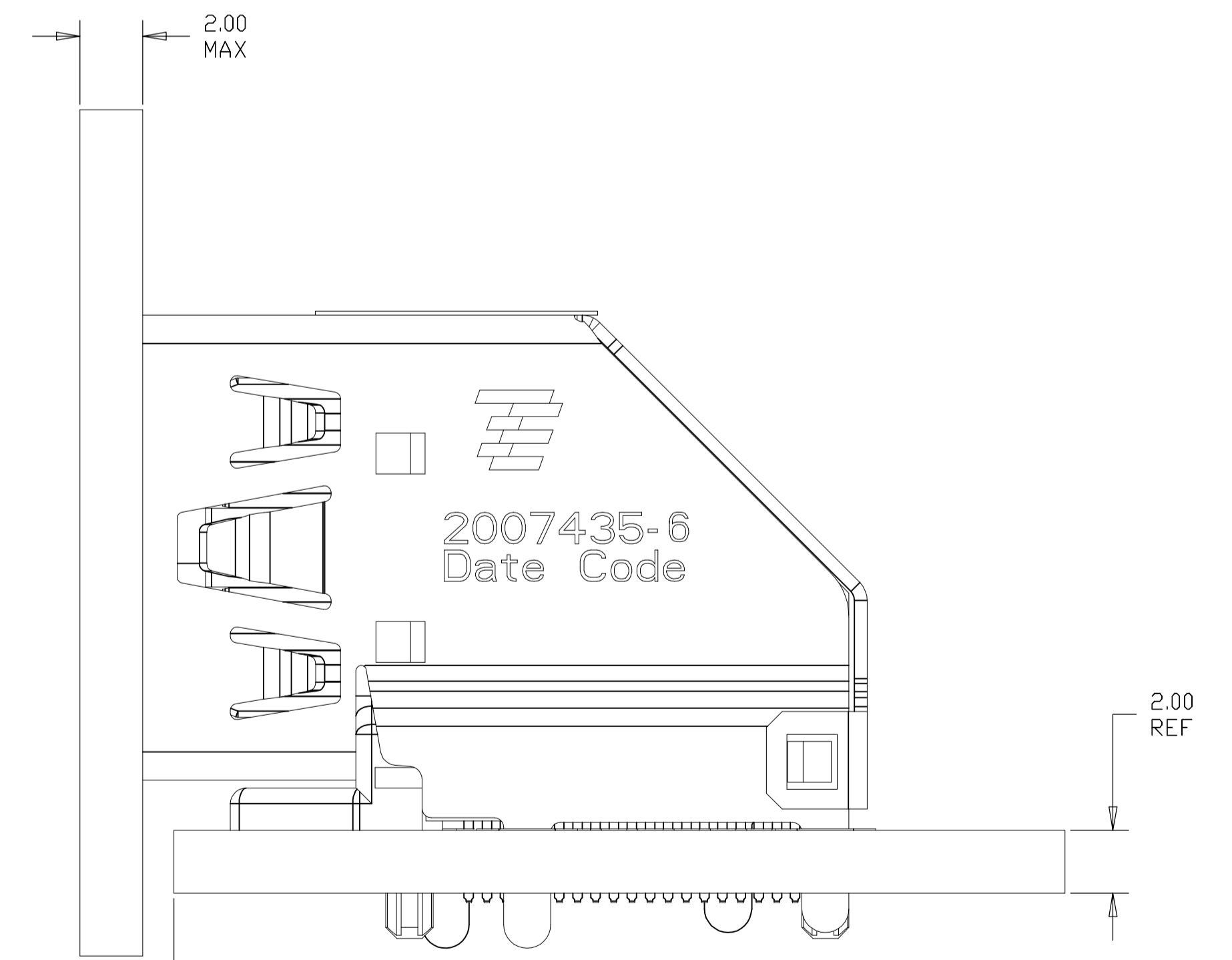
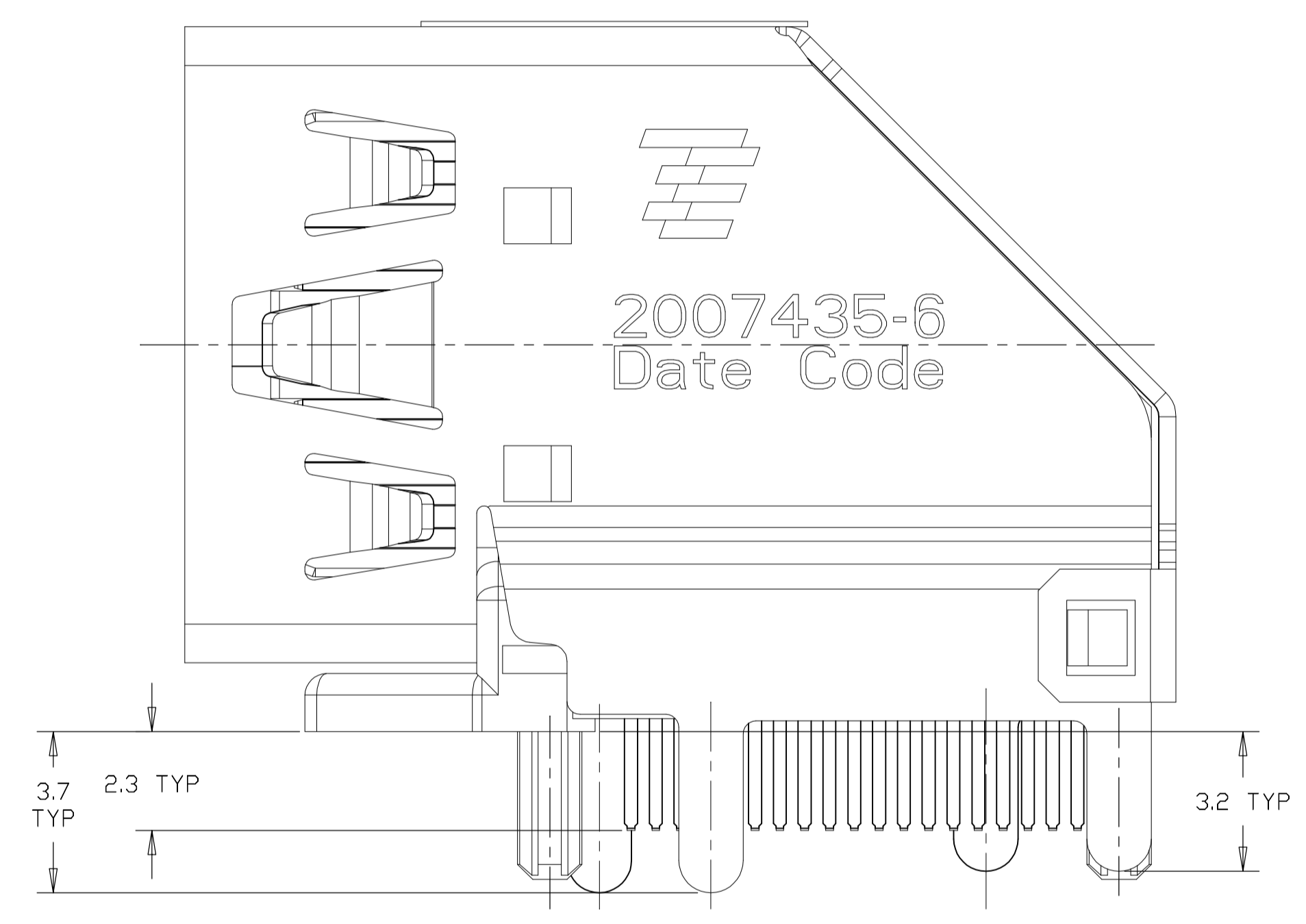
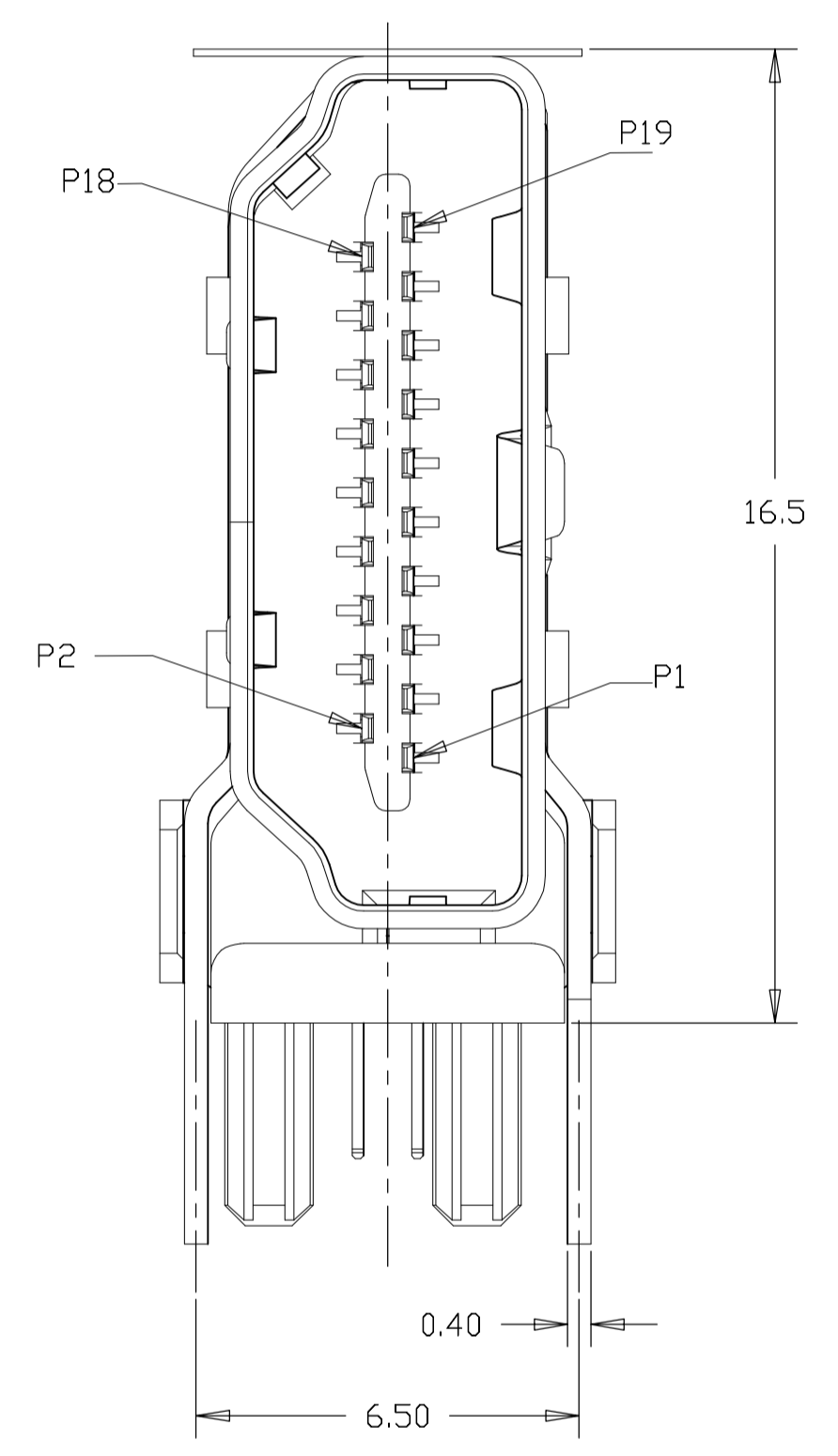

INSTALLED CONDITION
SCALE 6:1

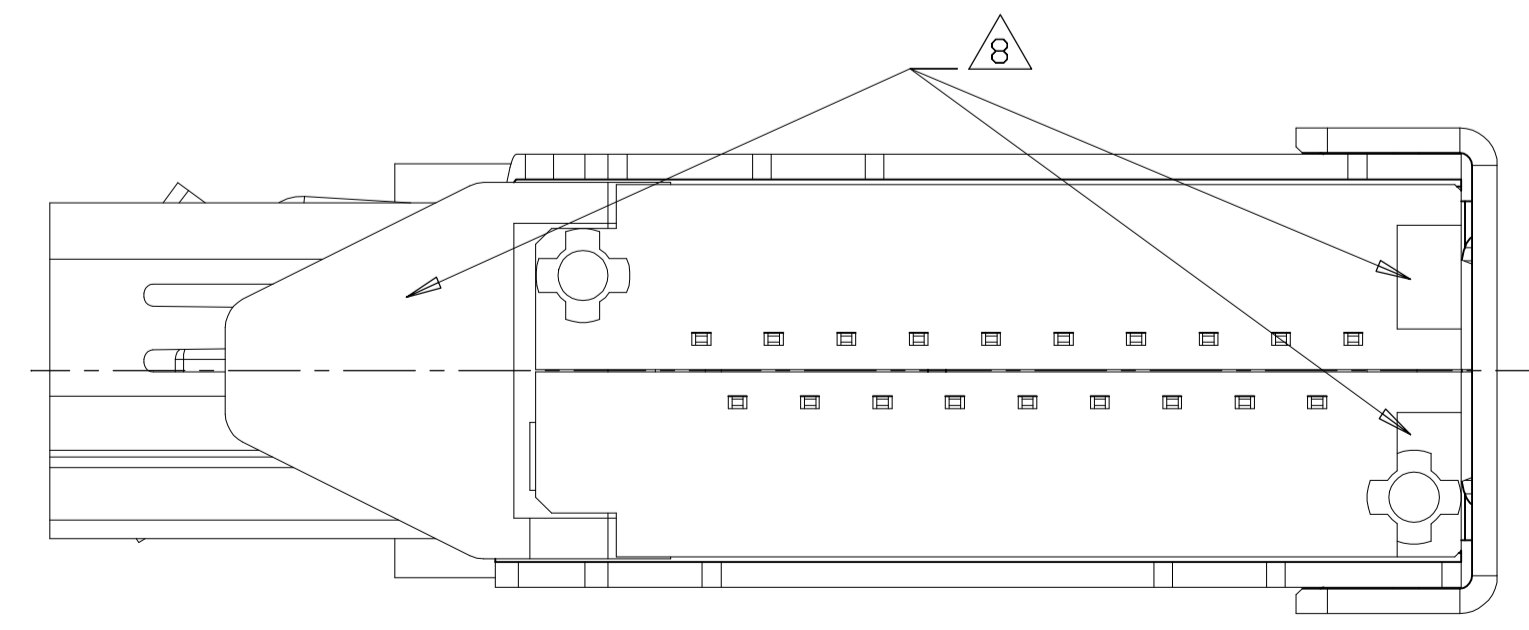

THIS DRAWING IS A CONTROLLED DOCUMENT.		DIN		STE		TE Connectivity	
DIMENSIONS: mm		TOLERANCES UNLESS OTHERWISE SPECIFIED:		NAME		HDMI FLAG CONNECTOR ASSEMBLY	
<ul style="list-style-type: none"> 0. PLC ± 0.3 1. PLC ± 0.25 2. PLC ± 0.10 3. PLC ± 0.10 4. PLC ± 0.10 ANGLES ± - 		<ul style="list-style-type: none"> APVD PRODUCT SPEC APPLICATION SPEC WEIGHT 		SIZE		RESTRICTED TO	
MATERIAL SEE TABLE		FINISH		A1 00779 C=2007435		SCALE 8:1 SHEET 5 OF 10 REV D2	
CUSTOMER DRAWING							

LOC		DIST		REVISIONS			
P	LTR	DESCRIPTION	DATE	OWN	APVD		
-	-	SEE SHEET 1	-	-	-	-	-

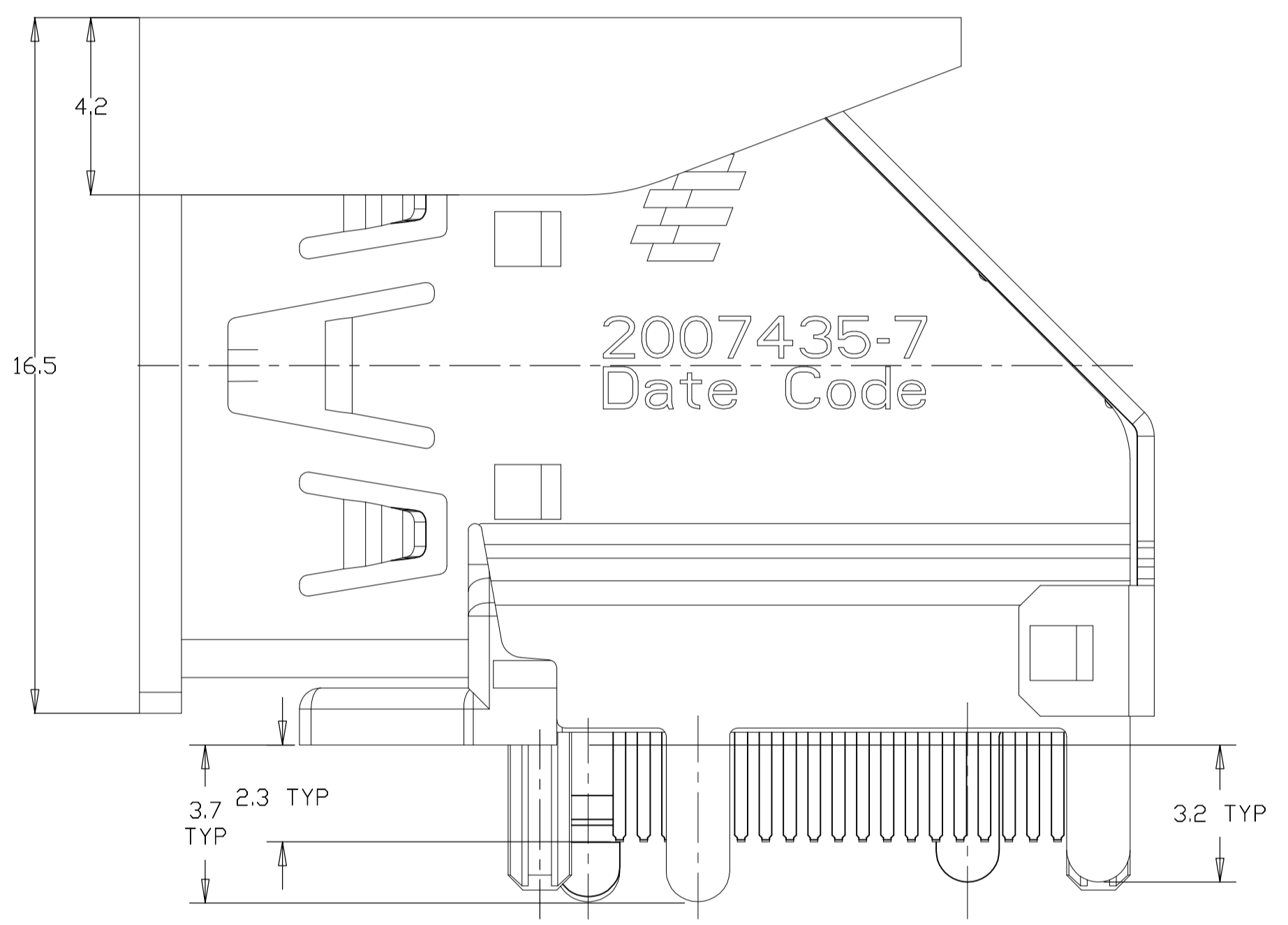
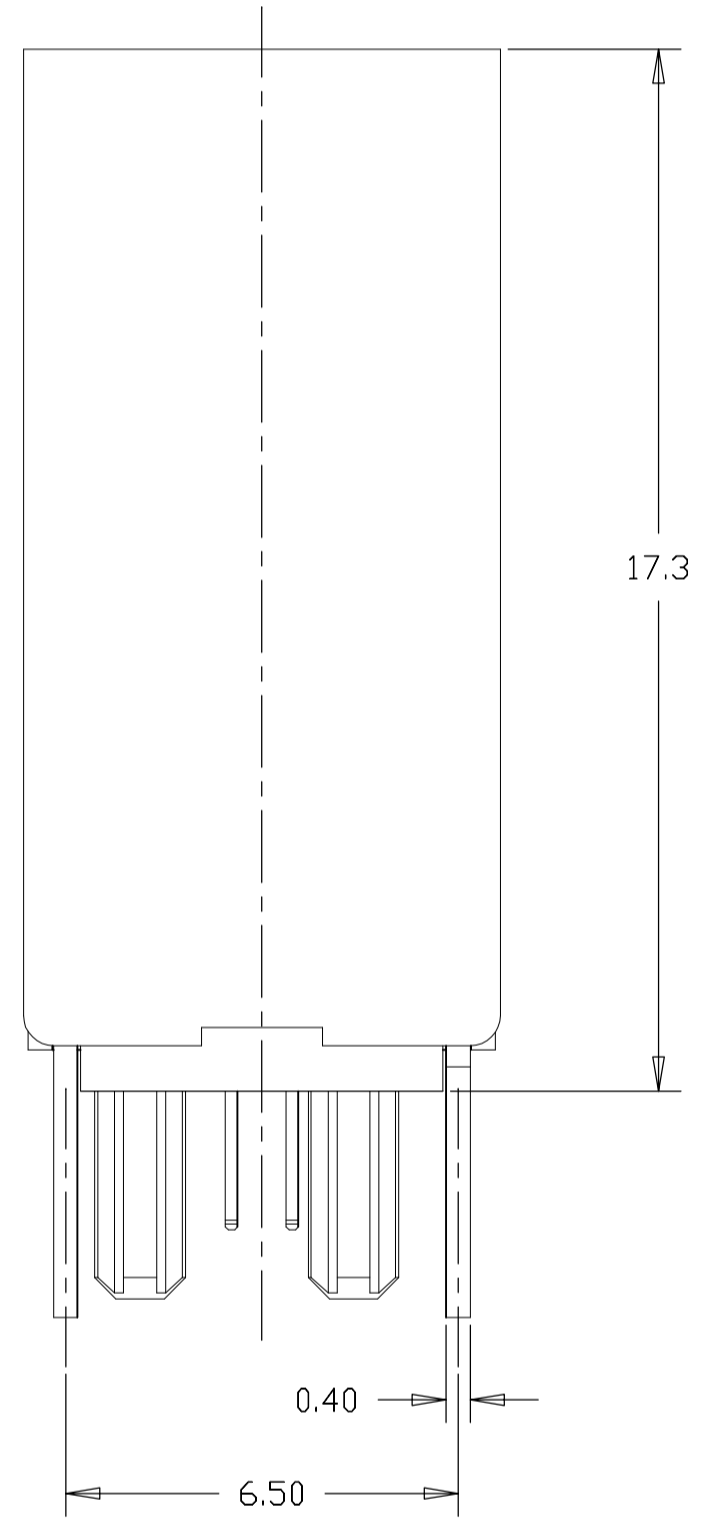
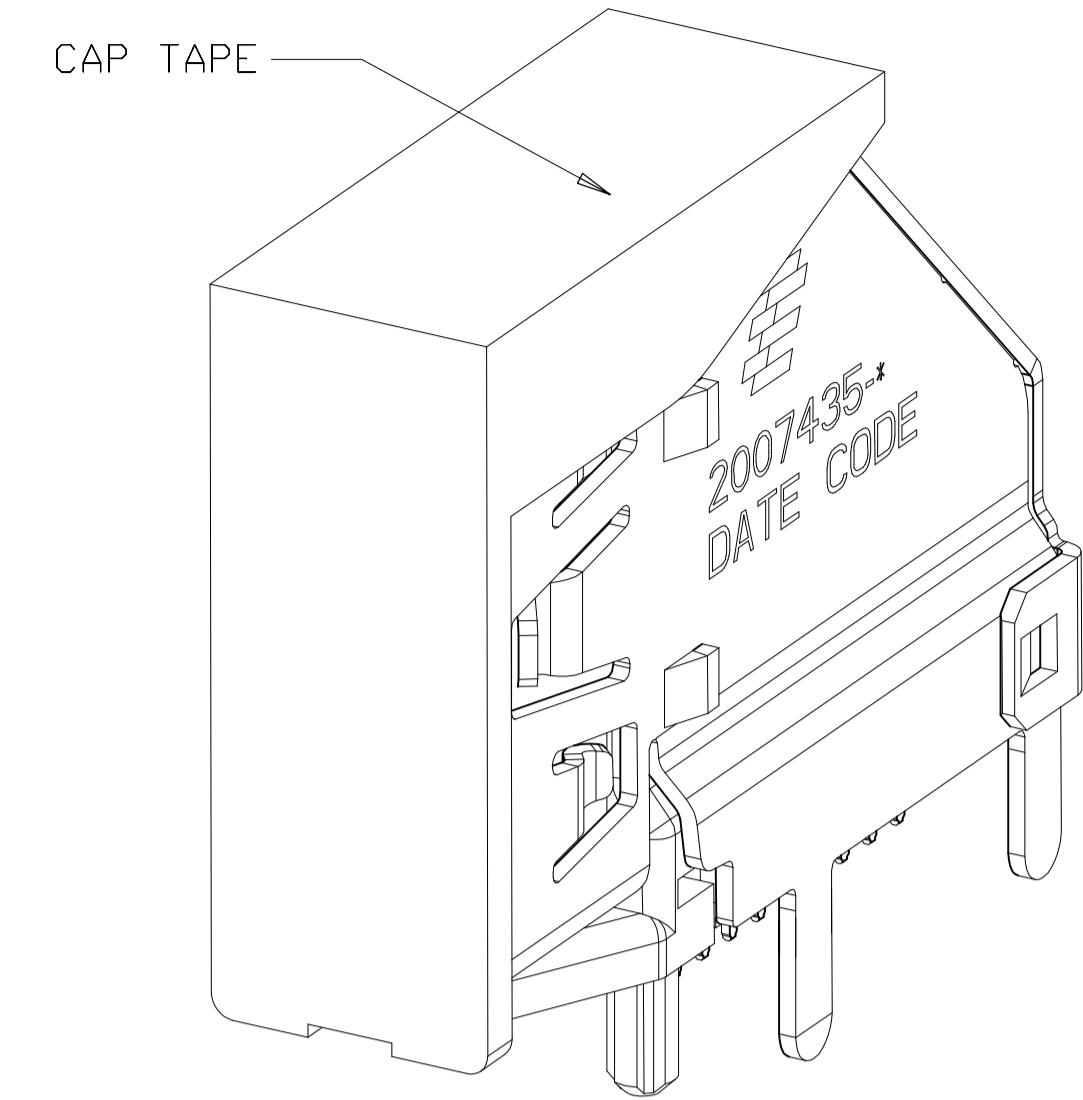
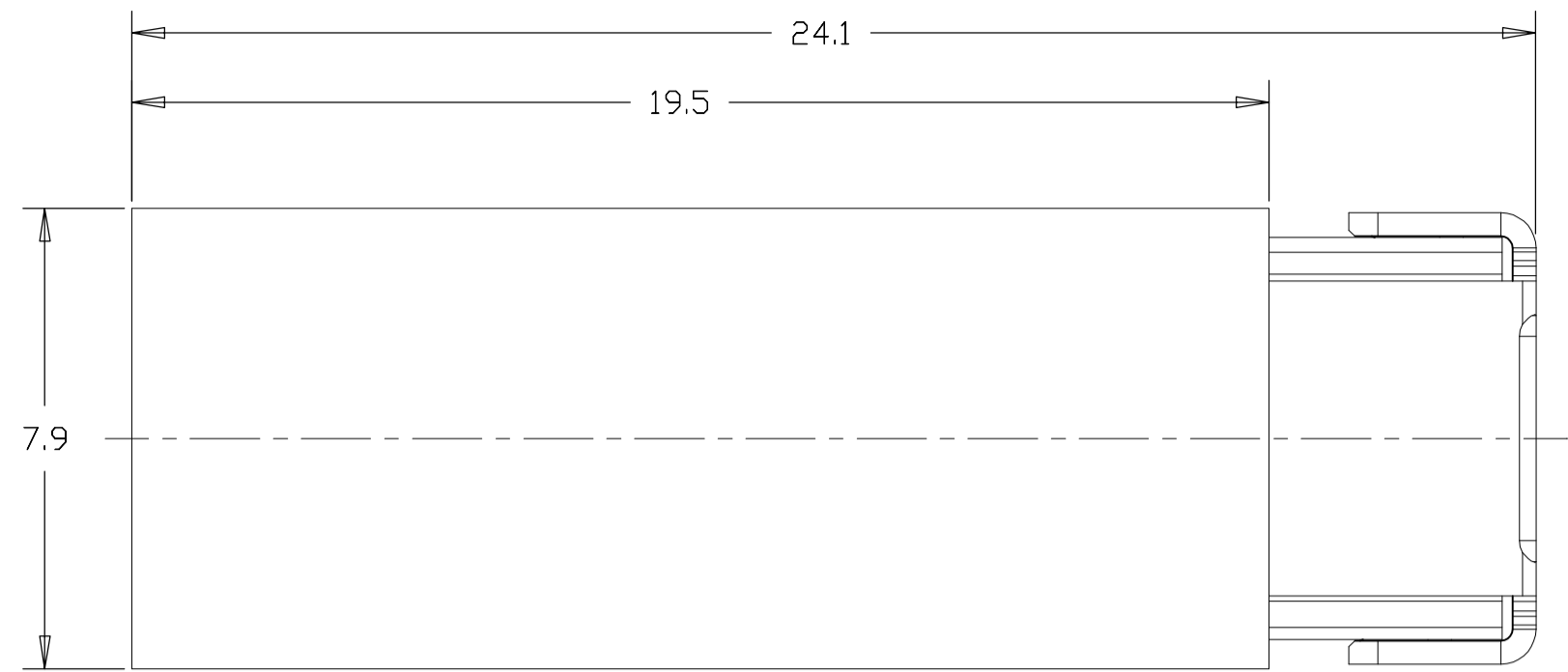

2007435-7 WITH CAP,
 UNMARKED DIMENSIONS SAME AS 2007435-1

SCALE 6:1

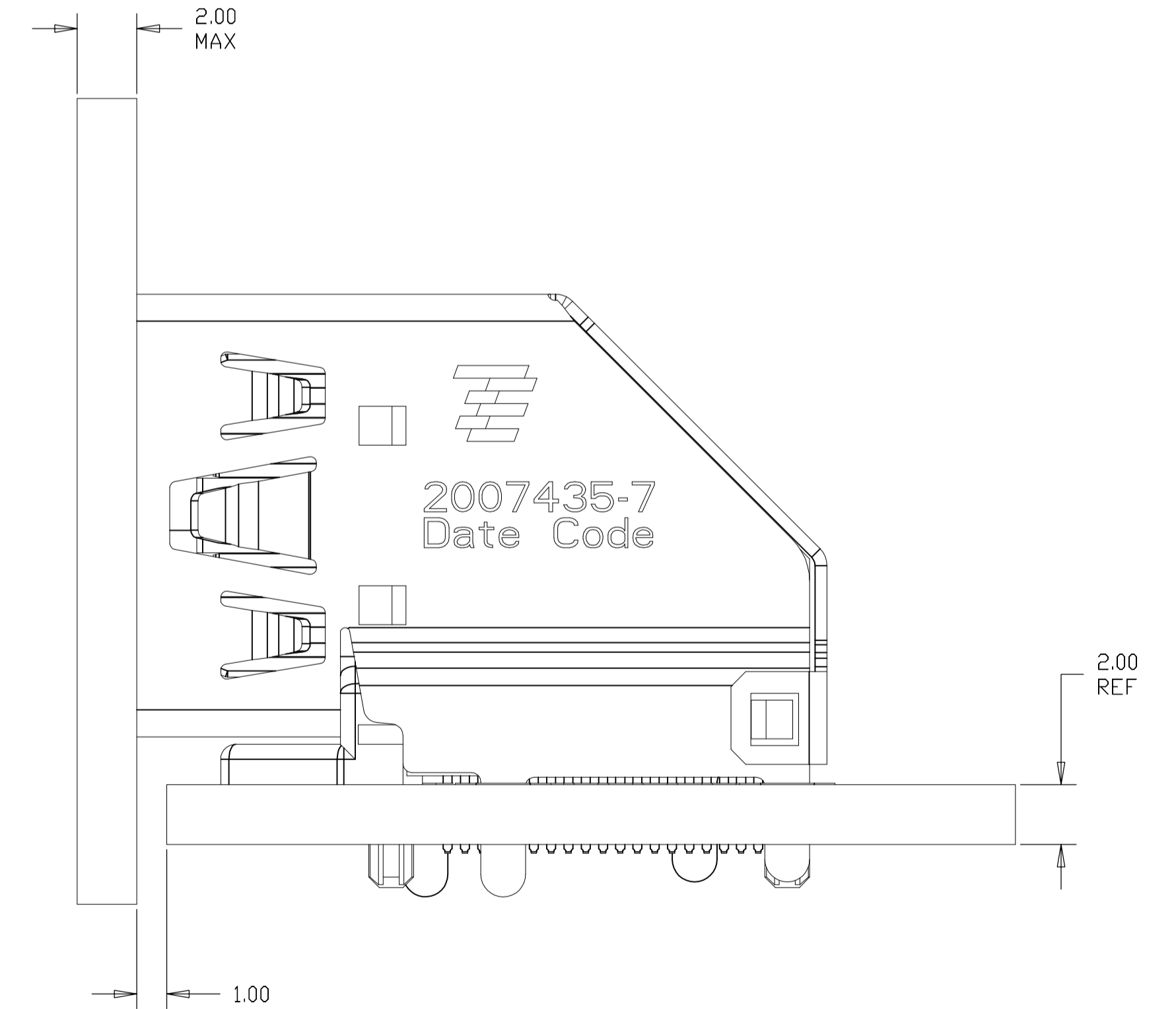

INSTALLED CONDITION
 (ONLY FOR AFTER REMOVE CAP)
 SCALE 6:1

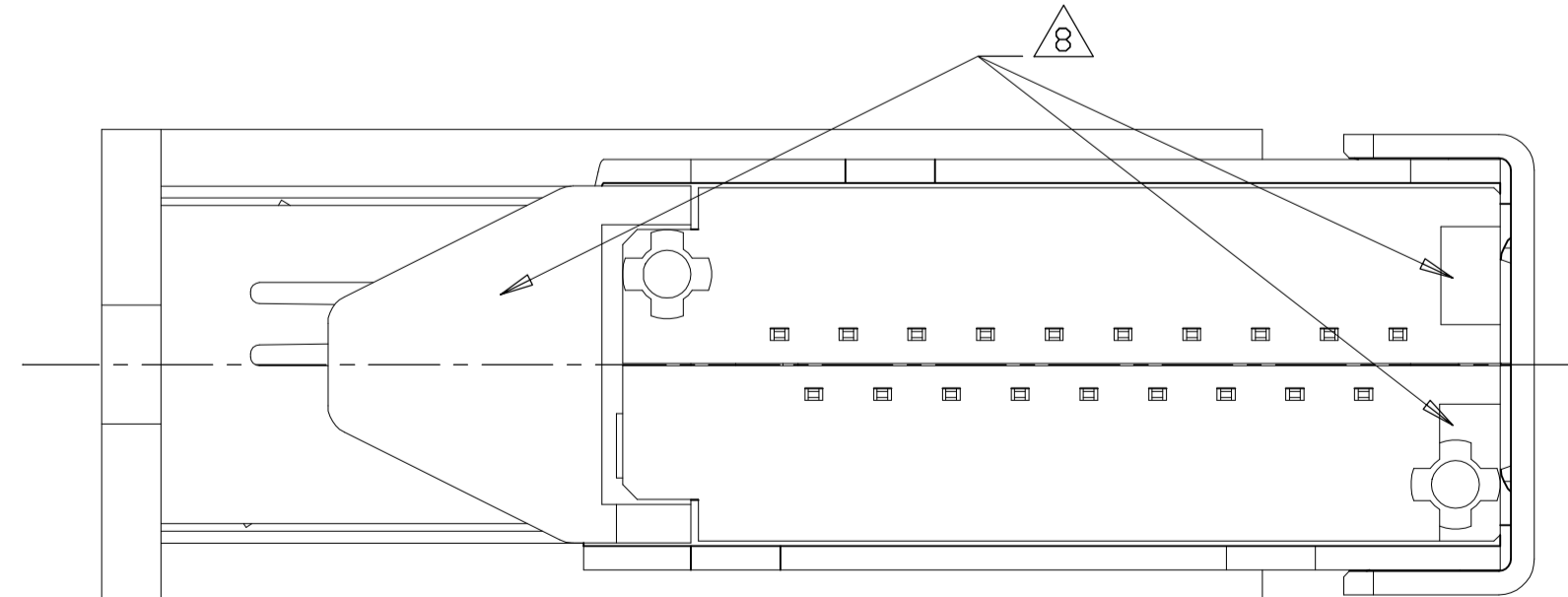

THIS DRAWING IS A CONTROLLED DOCUMENT.		DWN	TE Connectivity	
DIMENSIONS: mm		CHK	NAME	
TOLERANCES UNLESS OTHERWISE SPECIFIED:		APVD	HDMI FLAG CONNECTOR ASSEMBLY	
0 PLC	± 0.3	PRODUCT SPEC	-	
1 PLC	± 0.25	APPLICATION SPEC	-	
2 PLC	± 0.10	WEIGHT	-	
3 PLC	± 0.10	CUSTOMER DRAWING	-	
4 PLC	± 0.10	SCALE	8:1	
ANGLES	±	SHEET	6 OF 10	
MATERIAL SEE TABLE	FINISH	REV	D2	
SIZE CAGE CODE DRAWING NO		A1 00779 C=2007435		

LOC		DIST		REVISIONS			
P	LTR	DESCRIPTION	DATE	DNW	APVD		
-	-	SEE SHEET 1	-	-	-	-	-

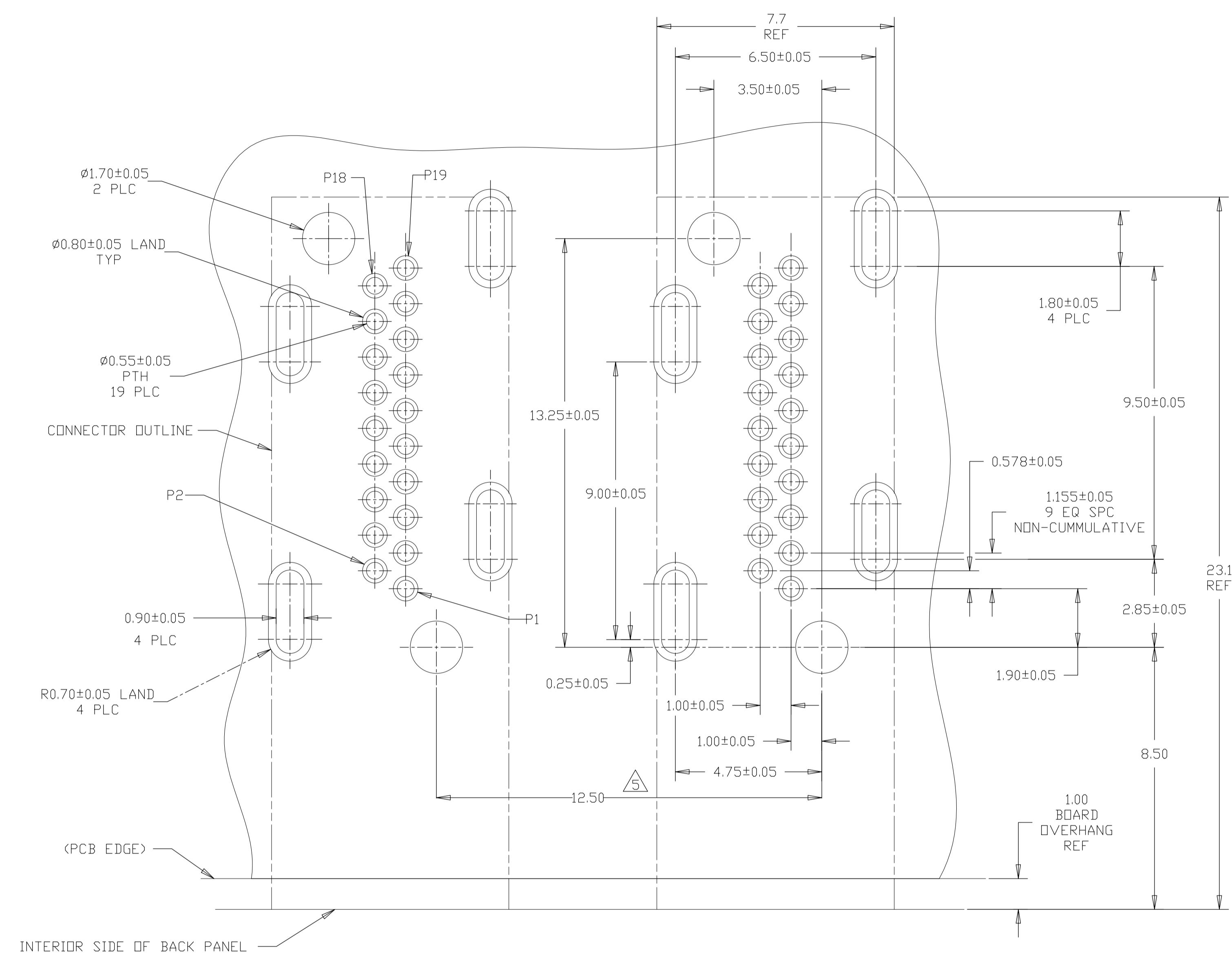

PCB LAYOUT SCALE 10:1

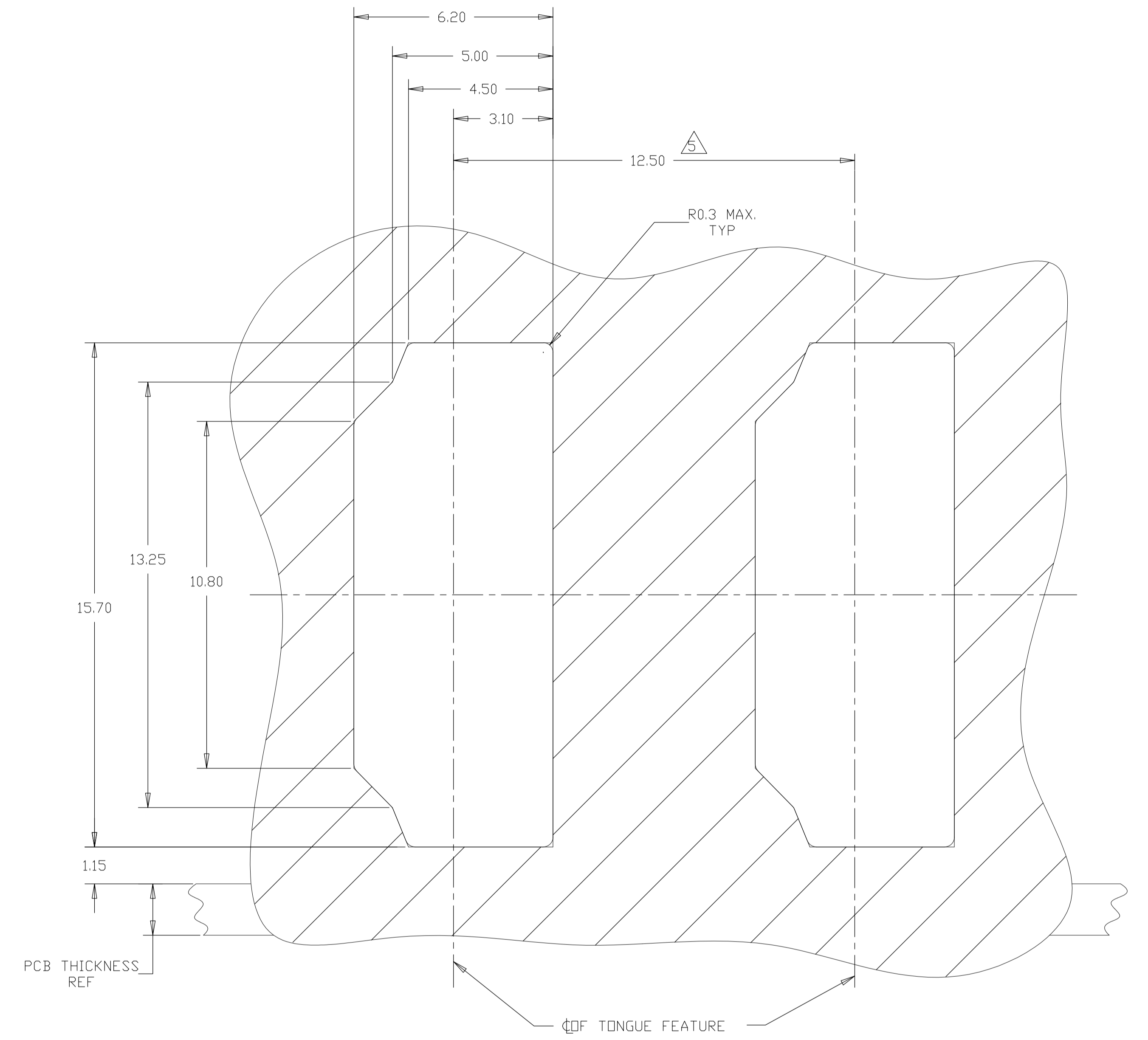

RECOMMENDED PANEL CUTOUT SCALE 10:1

THIS DRAWING IS A CONTROLLED DOCUMENT.		DIN	STE TE Connectivity	
DIMENSIONS: mm		CHK	NAME	
TOLERANCES UNLESS OTHERWISE SPECIFIED:		APVD	HDMI FLAG CONNECTOR ASSEMBLY	
0 PLC ± -		PRODUCT SPEC	-	
1 PLC ± 0.1		APPLICATION SPEC	-	
2 PLC ± 0.10		SIZE	A1	00779
3 PLC ± 0.100		CAGE CODE	C=2007435	DRAWING NO
4 PLC ± 0.1000		WEIGHT	-	RESTRICTED TO
ANGLES ± -		CUSTOMER DRAWING	SCALE 8:1	SHEET 7 OF 10

LOC		DIST		REVISIONS			
P	LTR	DESCRIPTION	DATE	DNW	APVD		
-	-	SEE SHEET 1	-	-	-	-	-

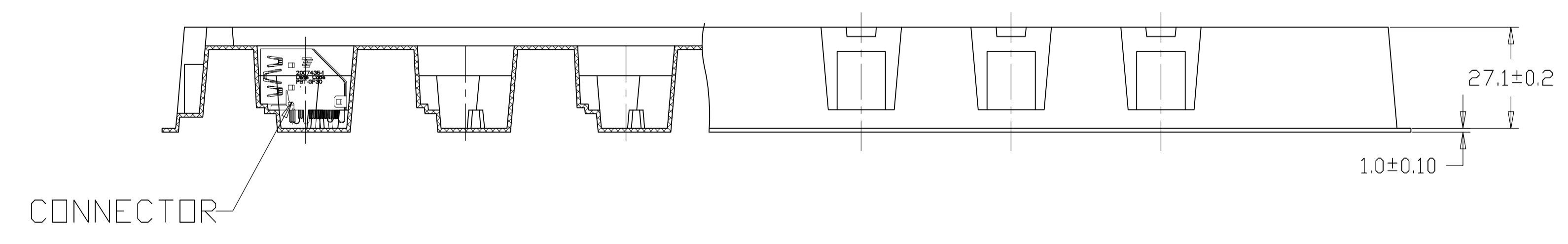
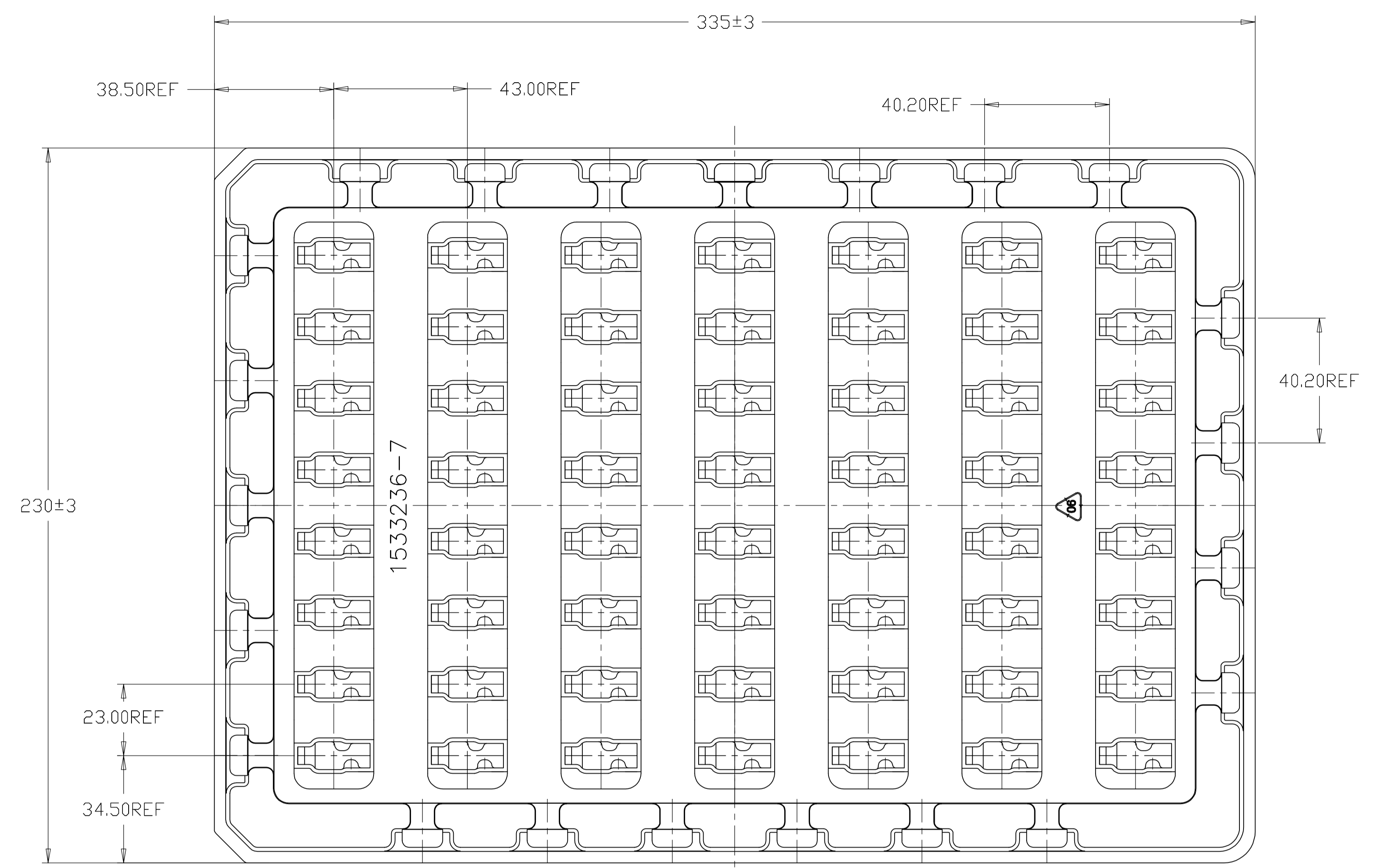

PACKAGE TRAY
FOR PART NUMBER
2007435-1,-2,-3,-4,-5
2-2007435-1

THIS DRAWING IS A CONTROLLED DOCUMENT.		DIN		STE		TE Connectivity	
DIMENSIONS: mm		TOLERANCES UNLESS OTHERWISE SPECIFIED:		NAME		HDMI FLAG CONNECTOR ASSEMBLY	
<ul style="list-style-type: none"> 0. PLC ± .1 1. PLC ± .1 2. PLC ± .1 3. PLC ± .1 4. PLC ± .1 ANGLES ± .5 		<ul style="list-style-type: none"> APVD PRODUCT SPEC APPLICATION SPEC 		SIZE		RESTRICTED TO	
MATERIAL		FINISH		WEIGHT		A1 00779 C=2007435	
CUSTOMER DRAWING				SCALE		SHEET 8 OF 10 REV D2	

LOC		DIST		REVISIONS			
P	LTR	DESCRIPTION	DATE	DN	APVD		
-	-	SEE SHEET 1	-	-	-	-	-

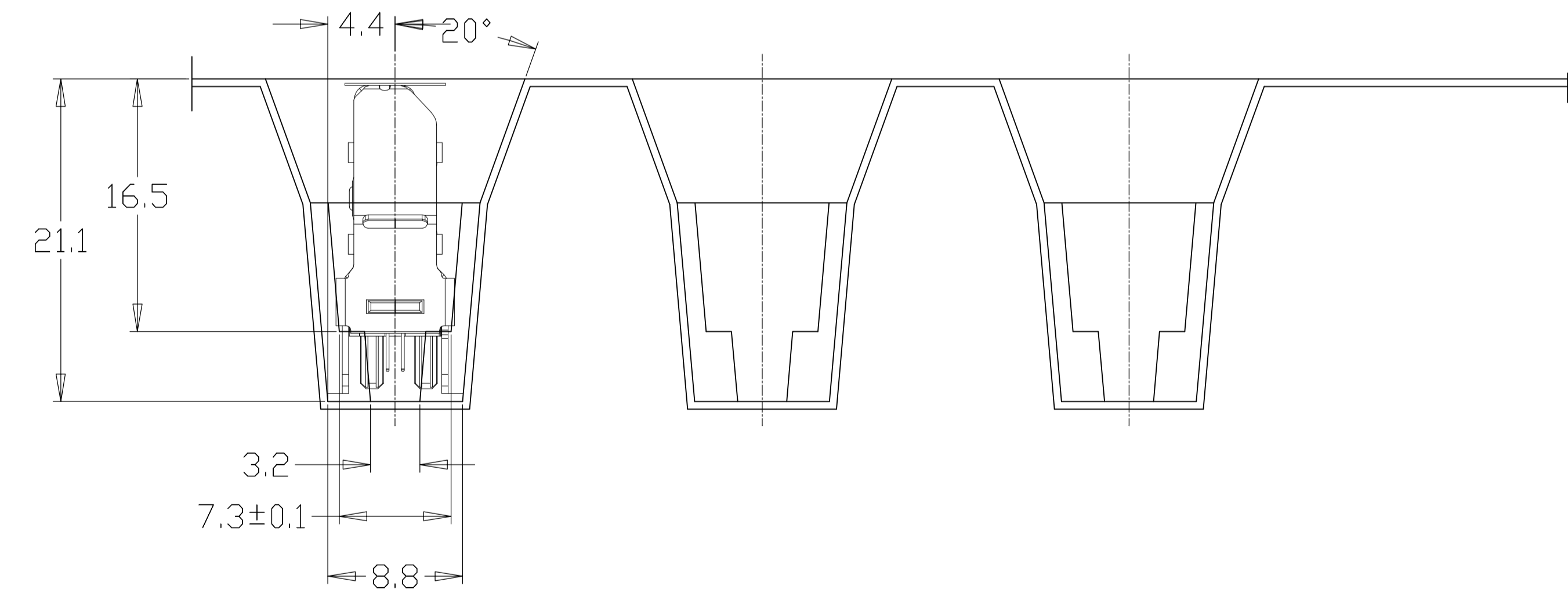
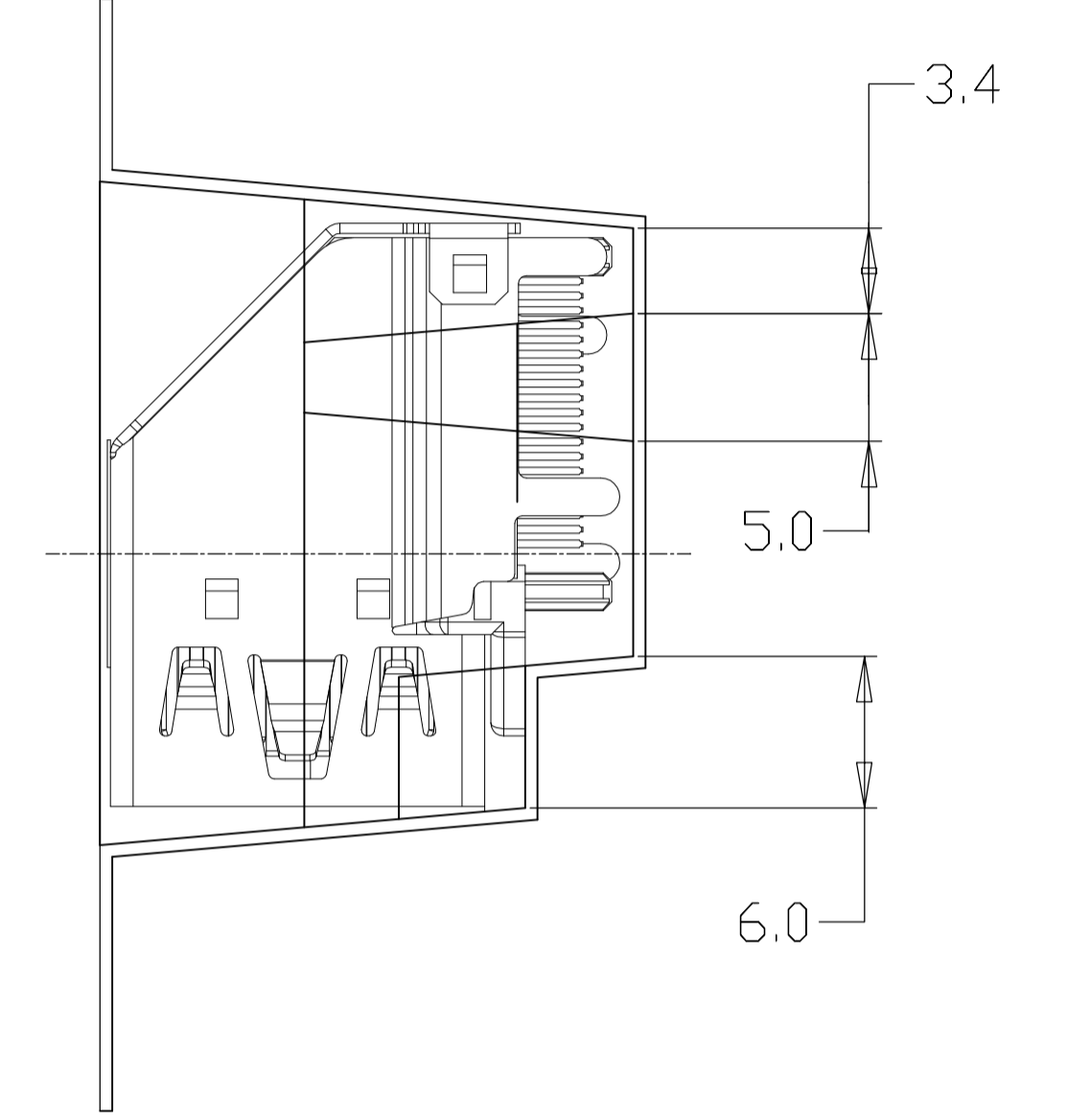
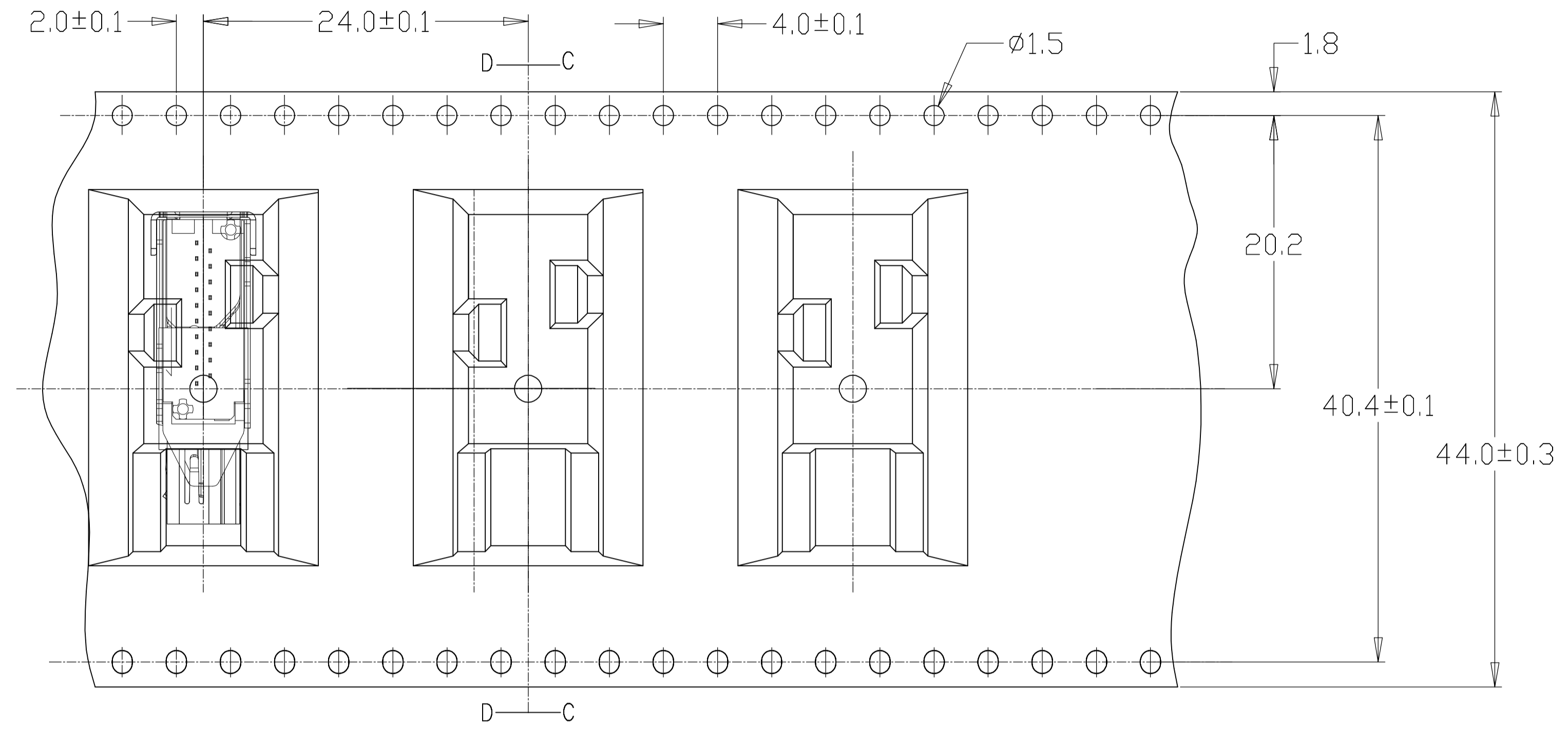
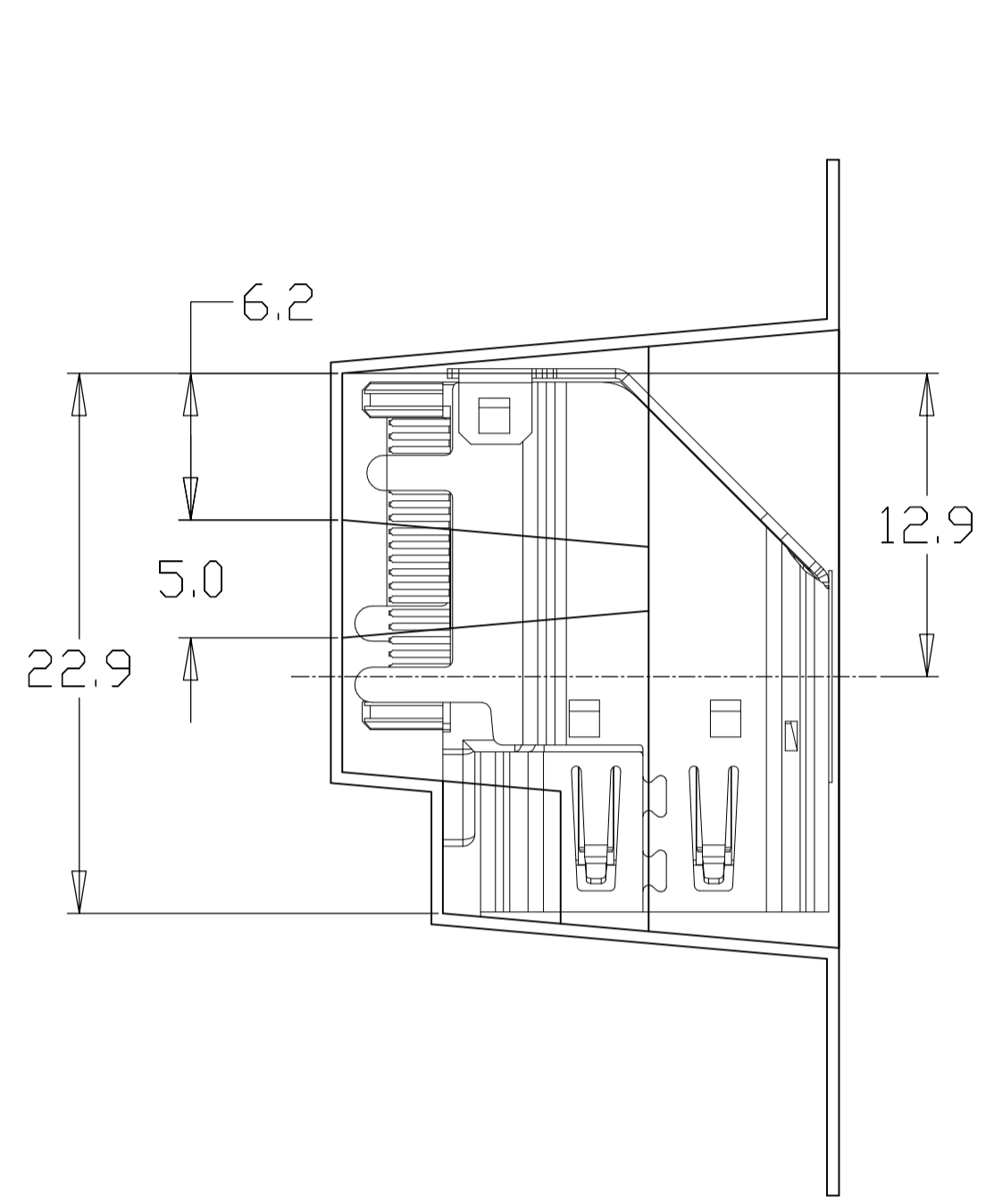

EMBOSS TAPE
FOR PART NUMBER 2007435-6

THIS DRAWING IS A CONTROLLED DOCUMENT.		DIN	TE Connectivity	
DIMENSIONS: mm		CHK		
DIMENSIONS: mm TOLERANCES UNLESS OTHERWISE SPECIFIED: 0. PLC ± 0.3 1. PLC ± 0.15 2. PLC ± 0.10 3. PLC ± 0.10 4. PLC ± 0.10 ANGLES ± 0.10		APVD	NAME	
		PRODUCT SPEC	HDMI FLAG CONNECTOR ASSEMBLY	
MATERIAL		APPLICATION SPEC	RESTRICTED TO	
FINISH		WEIGHT	SIZE	CAGE CODE
			A1	00779
		CUSTOMER DRAWING	SCALE	SHEET
			N/A	9 of 10
				REV D2

LOC		DIST		REVISIONS			
P	LTR	DESCRIPTION	DATE	DN	APVD		
-	-	SEE SHEET 1	-	-	-	-	-

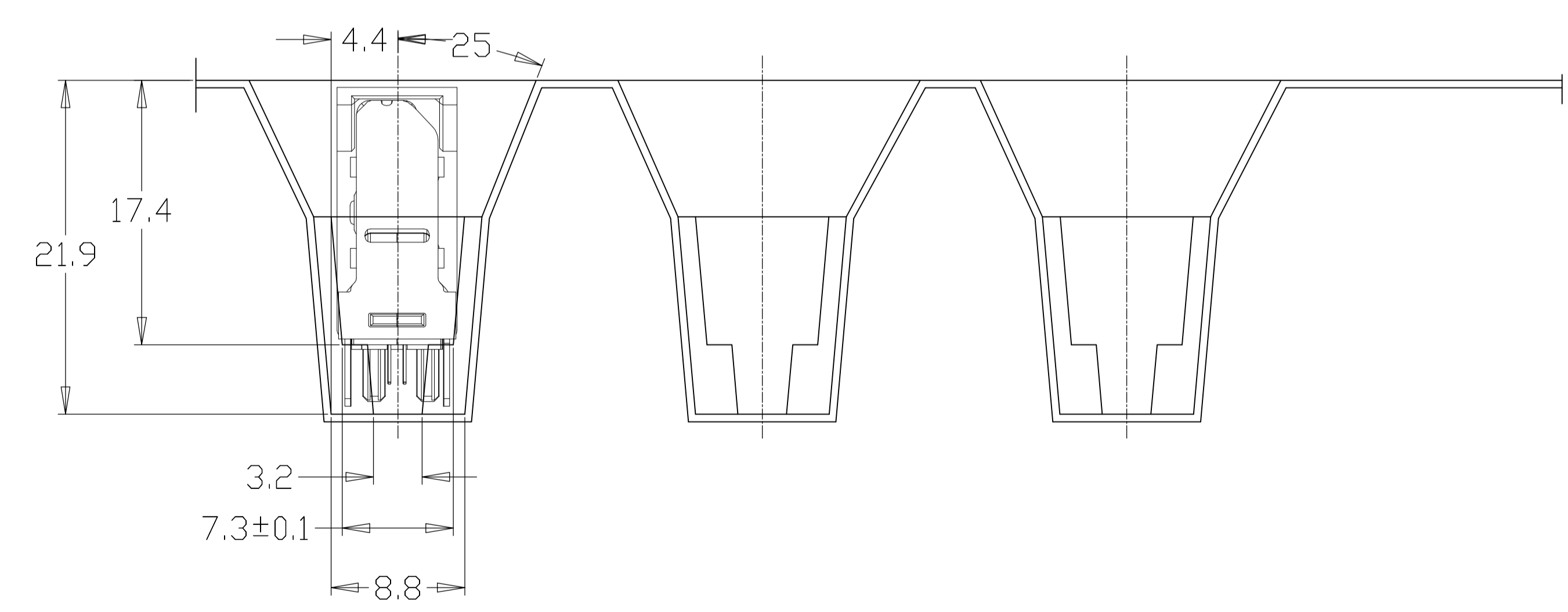
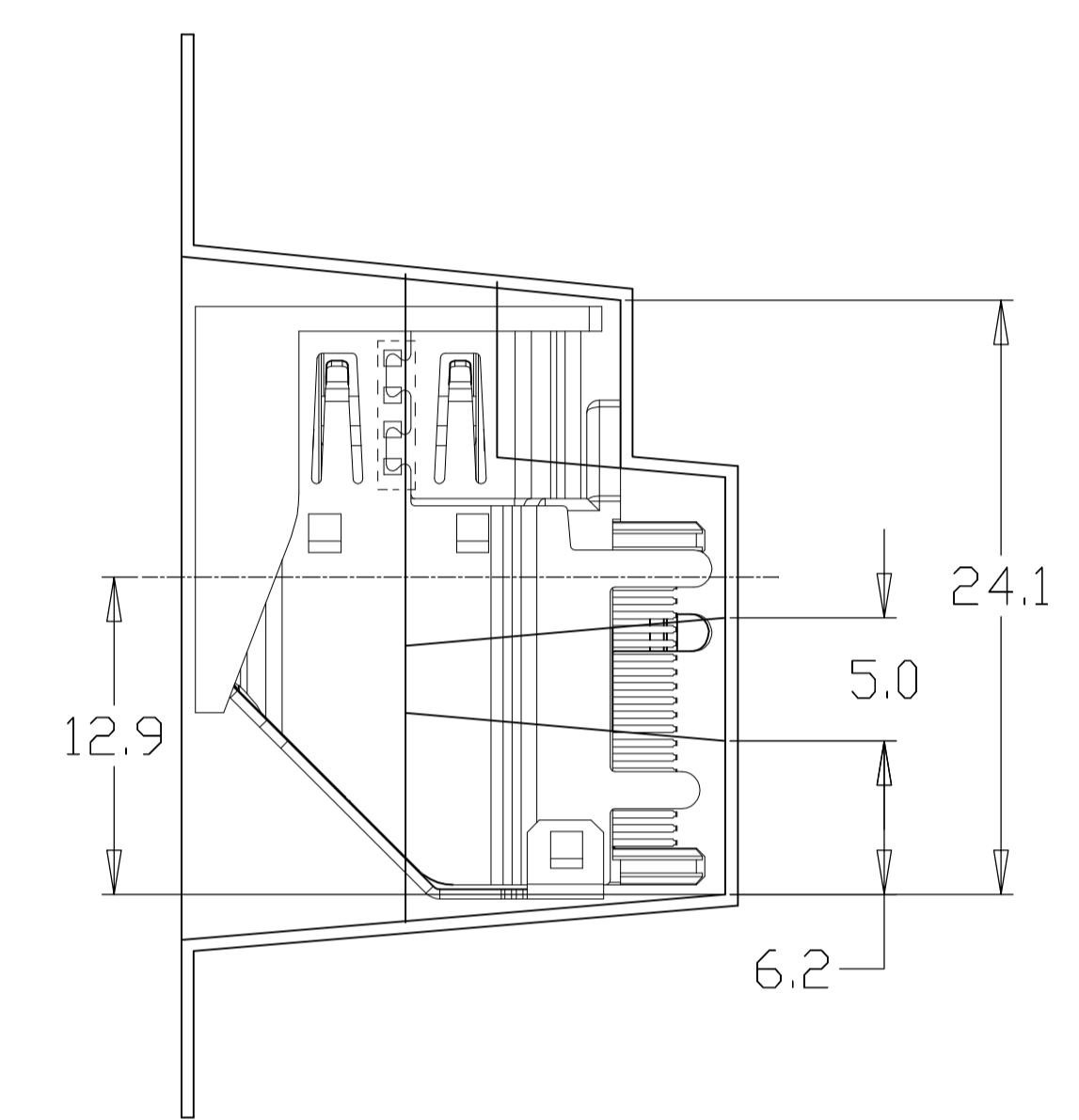
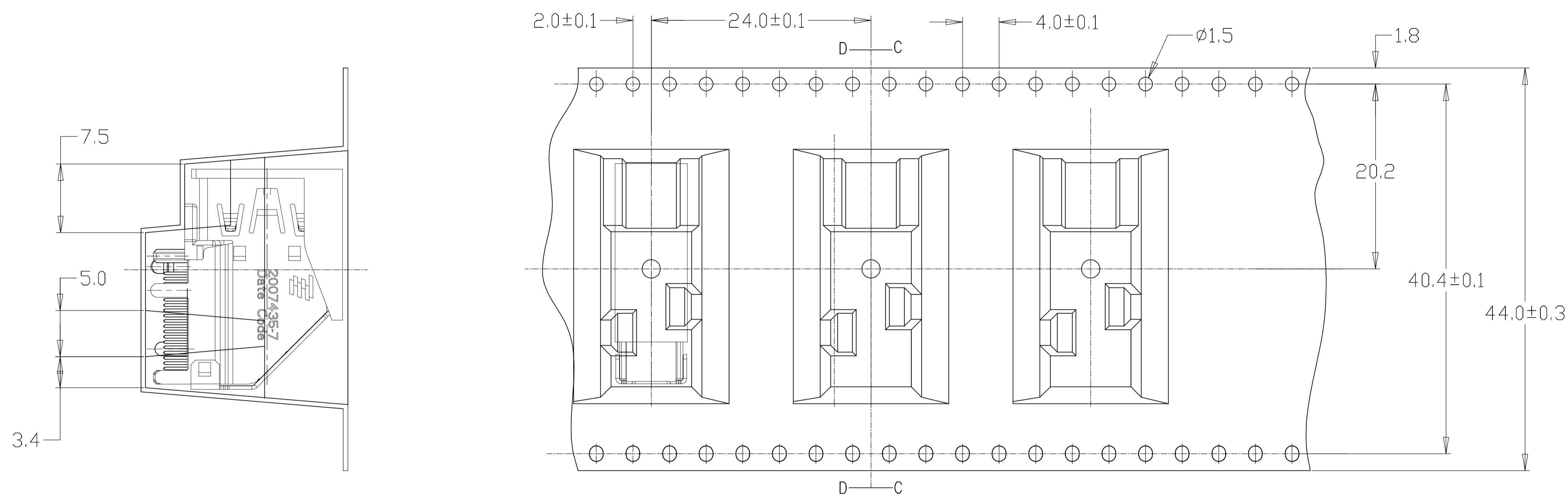

EMBOSS TAPE
FOR PART NUMBER 2007435-7

THIS DRAWING IS A CONTROLLED DOCUMENT.		DIN		TE Connectivity	
DIMENSIONS: mm		CHK			
TOLERANCES UNLESS OTHERWISE SPECIFIED:		APVD		NAME	
0. PLC ± 0.3		PRODUCT SPEC		HDMI FLAG CONNECTOR ASSEMBLY	
1. PLC ± 0.15		APPLICATION SPEC		-	
2. PLC ± 0.10		WEIGHT		SIZE CAGE CODE DRAWING NO. RESTRICTED TO	
3. PLC ± 0.10		CUSTOMER DRAWING		A1 00779 C=2007435	
4. PLC ± 0.10		SCALE N/A		SHEET 10 OF 10 REV D2	
ANGLES ±					
FINISH					

Компания «Life Electronics» занимается поставками электронных компонентов импортного и отечественного производства от производителей и со складов крупных дистрибьюторов Европы, Америки и Азии.

С конца 2013 года компания активно расширяет линейку поставок компонентов по направлению коаксиальный кабель, кварцевые генераторы и конденсаторы (керамические, пленочные, электролитические), за счёт заключения дистрибьюторских договоров

Мы предлагаем:

- Конкурентоспособные цены и скидки постоянным клиентам.
- Специальные условия для постоянных клиентов.
- Подбор аналогов.
- Поставку компонентов в любых объемах, удовлетворяющих вашим потребностям.
- Приемлемые сроки поставки, возможна ускоренная поставка.
- Доставку товара в любую точку России и стран СНГ.
- Комплексную поставку.
- Работу по проектам и поставку образцов.
- Формирование склада под заказчика.
- Сертификаты соответствия на поставляемую продукцию (по желанию клиента).
- Тестирование поставляемой продукции.
- Поставку компонентов, требующих военную и космическую приемку.
- Входной контроль качества.
- Наличие сертификата ISO.

В составе нашей компании организован Конструкторский отдел, призванный помогать разработчикам, и инженерам.

Конструкторский отдел помогает осуществить:

- Регистрацию проекта у производителя компонентов.
- Техническую поддержку проекта.
- Защиту от снятия компонента с производства.
- Оценку стоимости проекта по компонентам.
- Изготовление тестовой платы монтаж и пусконаладочные работы.



Тел: +7 (812) 336 43 04 (многоканальный)

Email: org@lifeelectronics.ru