

# Loss-of-Sync Alarm

## General Description

The MAX7461 single-channel loss-of-sync alarm ( $\overline{\text{LOS}}$ ) provides composite video sync detection in NTSC, PAL, and SECAM standard-definition television (SDTV) systems. The MAX7461's advanced detection circuitry delivers robust performance by preventing false loss-of-sync alarms due to noise. The device accepts an AC-coupled composite (CVBS), luma (Y), or any other video signal with sync, and outputs a logic-level signal. The open-drain  $\overline{\text{LOS}}$  output is low when no sync is detected and high impedance when sync is detected. The device operates from a single +5V supply.

The MAX7461 is available in a 5-pin SOT23 package and is specified for operation over the -40°C to +85°C temperature range.

## Applications

Security Systems  
Consumer Electronics

## Ordering Information

PART	TEMP RANGE	PIN-PACKAGE	PACKAGE CODE
MAX7461EUK	-40°C to +85°C	5 SOT23	U5-2

## Features

- ◆ Accepts CVBS, Y, or Any Other Video with Sync
- ◆ Loss-of-Sync Alarm Output
- ◆ Robust Performance in Noisy Environments
- ◆ Wire-OR Alarm Output
- ◆ NTSC, PAL, and SECAM
- ◆ Small 5-Pin SOT23 Package

## Pin Configuration

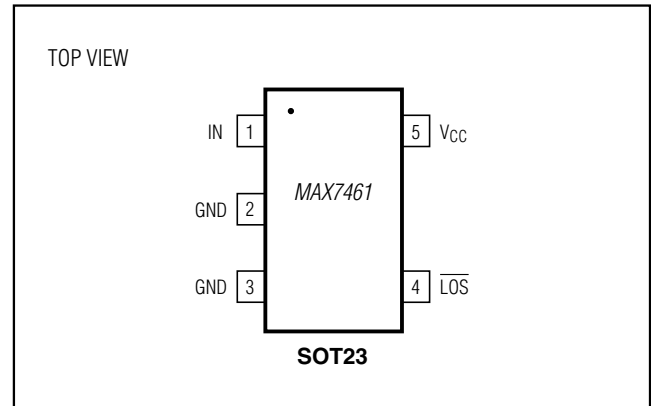

## Functional Diagram

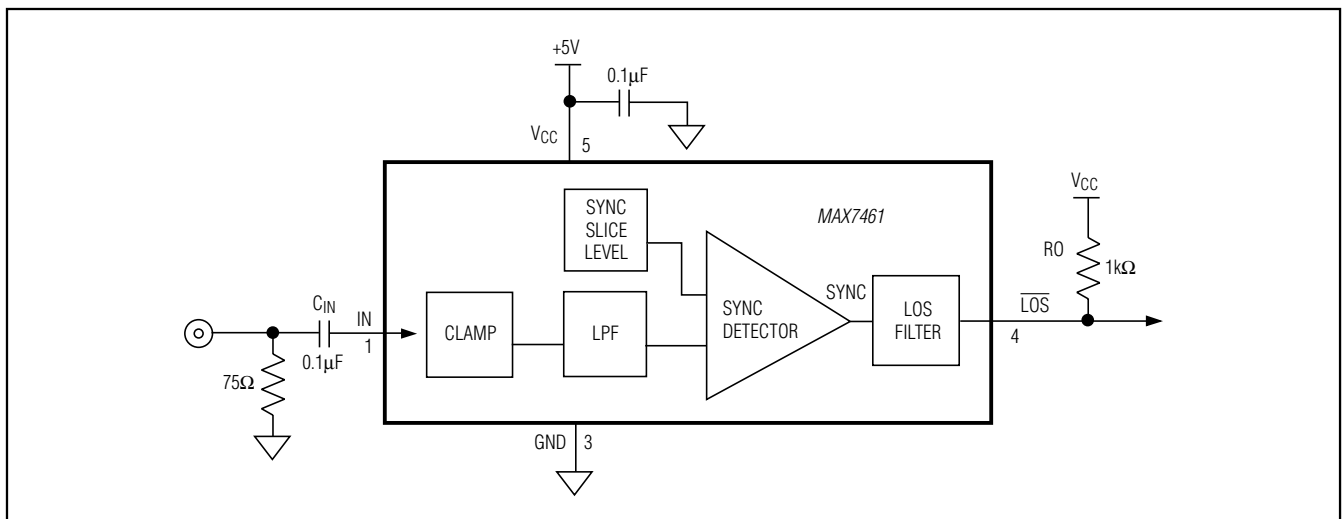

# MAX7461

## Loss-of-Sync Alarm

### ABSOLUTE MAXIMUM RATINGS

V <sub>CC</sub> to GND	-0.3V to +6V
LOS to GND	-0.3V to +6V
IN to GND	-0.3V to the lower of +6V and (V <sub>CC</sub> + 0.3V)
Continuous Power Dissipation (T <sub>A</sub> = +70°C)	
5-Pin SOT23-5 (derate 7.1mW/°C above +70°C)	571.0mW
Maximum Current Into Any Pin	±50mA

Operating Temperature Range	
MAX7461EUK	-40°C to +85°C
Storage Temperature Range	-65°C to +150°C
Lead Temperature (soldering, 10s)	+300°C
Junction Temperature	+150°C

Stresses beyond those listed under "Absolute Maximum Ratings" may cause permanent damage to the device. These are stress ratings only, and functional operation of the device at these or any other conditions beyond those indicated in the operational sections of the specifications is not implied. Exposure to absolute maximum rating conditions for extended periods may affect device reliability.

### ELECTRICAL CHARACTERISTICS

(V<sub>CC</sub> = +4.5V to +5.5V, GND = 0, C<sub>IN</sub> = 0.1μF, RO = 500Ω, T<sub>A</sub> = -40°C to +85°C, unless otherwise noted. Typical values are at T<sub>A</sub> = +25°C.)

PARAMETER	SYMBOL	CONDITIONS	MIN	TYP	MAX	UNITS
<b>AC CHARACTERISTICS</b>						
Minimum Input Sync Height	V <sub>IN-MIN</sub>	AC-coupled (Note 1)		105	130	mV <sub>P-P</sub>
Maximum Input Voltage	V <sub>IN-MAX</sub>	AC-coupled	2.4			V <sub>P-P</sub>
LOS Release Time	t <sub>RT</sub>	(Note 2)	1.7	2.2	2.7	ms
LOS Detect Time	t <sub>DT</sub>	(Note 3)	1.9	3.4	4.9	
<b>DIGITAL CHARACTERISTICS</b>						
Output Low Voltage	V <sub>OL</sub>	I <sub>SINK</sub> = 10mA			0.4	V
Logic High Leakage Current	I <sub>OLEAK</sub>				1	μA
<b>POWER REQUIREMENTS</b>						
Supply Voltage	V <sub>CC</sub>		4.5	5.0	5.5	V
Supply Current	I <sub>CC</sub>			1.7	2.2	mA
Power-Supply Noise Immunity	V <sub>PSNI</sub>	0 to 5MHz sinusoid on V <sub>CC</sub> (Note 4)		200		mV <sub>P-P</sub>

**Note 1:** Minimum input sync height is the voltage above which  $\overline{\text{LOS}}$  is guaranteed to be in high-impedance mode after the maximum LOS time-constant time.

**Note 2:** LOS release time is the time that the video input must be continuously present before  $\overline{\text{LOS}}$  goes high (inactive state).

**Note 3:** The LOS detect time is the time that the video input must be continuously absent before  $\overline{\text{LOS}}$  goes low (active state).

**Note 4:** The MAX7461  $\overline{\text{LOS}}$  output is accurate with a power-supply noise level below V<sub>PSNI</sub>.

# MAX7461

## Loss-of-Sync Alarm

### Typical Operating Characteristics

( $V_{CC} = 5V$ ,  $GND = 0$ ,  $C_{IN} = 0.1\mu F$ ,  $R_O = 10k\Omega$ ,  $T_A = +25^\circ C$ , unless otherwise noted.)

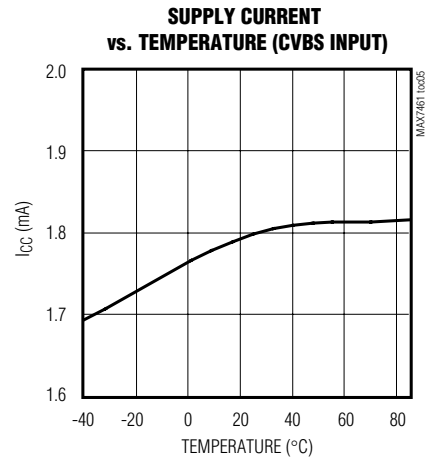
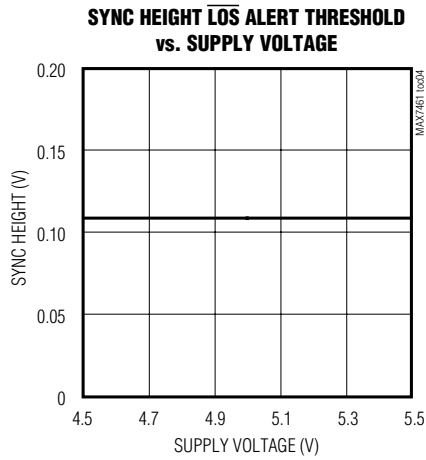
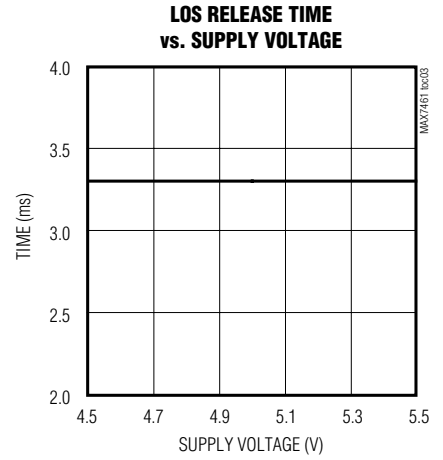
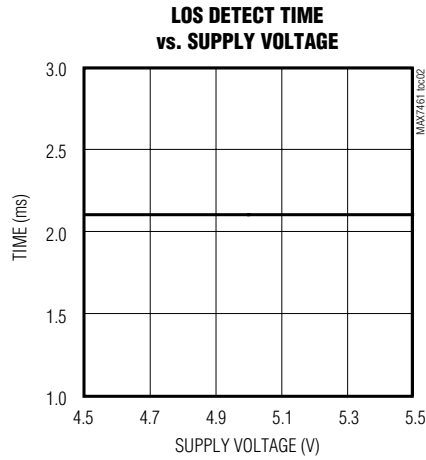
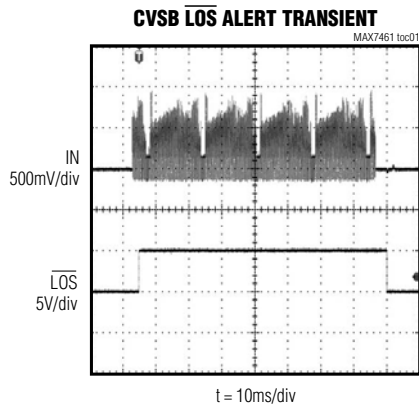

# MAX7461

## Loss-of-Sync Alarm

### Pin Description

PIN	NAME	FUNCTION
1	IN	Video Input. Accepts CVBS, luma (Y), or any video input with sync. AC-couple IN with a series 0.1 $\mu$ F capacitor.
2, 3	GND	Ground
4	$\overline{\text{LOS}}$	Loss-Of-Sync Output (Open Drain). $\overline{\text{LOS}}$ is in high impedance when sync pulses are detected, and is pulled low when no horizontal sync signal is detected for more than the LOS detect time. $\overline{\text{LOS}}$ returns high when sync pulses are detected for more than the LOS release time. Connect a 1k $\Omega$ pullup resistor from $\overline{\text{LOS}}$ to V <sub>CC</sub> .
5	V <sub>CC</sub>	Power-Supply Input. Bypass to GND with a 0.1 $\mu$ F capacitor.

### Detailed Description

The MAX7461 single-channel LOS alarm is ideal for any video system needing to verify the presence of a video source. The device accepts an AC-coupled CVBS, Y, or any video signal with sync, and pulls  $\overline{\text{LOS}}$  low when no composite sync signal is detected for more than the LOS detect time (3.4ms, typ) at the input (IN).

#### Clamp

The MAX7461 features an input clamp that corrects any DC shift, on a line-by-line basis. The external AC-coupling capacitor provides DC isolation for the input.

#### Lowpass Filter

The MAX7461 integrates a lowpass filter for enhanced sync detection. The lowpass filter prevents false sync detection by reducing color burst, chroma, and noise.

#### Sync Detector/LOS Filter

The sync detector looks for sync pulses greater than the minimum sync voltage (0.13V<sub>P-P</sub>). If the detector does not detect any sync pulses for 3.4ms (typ), the LOS filter pulls  $\overline{\text{LOS}}$  low. After detecting sync for at least 2.2ms (typ), the LOS filter returns  $\overline{\text{LOS}}$  to a high-impedance state.  $\overline{\text{LOS}}$  is an open-drain output. Connect a 1k $\Omega$  pullup resistor between  $\overline{\text{LOS}}$  and V<sub>CC</sub>.

#### Power-On Reset (POR)

At power-up,  $\overline{\text{LOS}}$  is pulled low and the MAX7461 checks for 2.2ms (typ) of valid sync pulses before releasing  $\overline{\text{LOS}}$ .  $\overline{\text{LOS}}$  remains high impedance while a valid sync signal is detected at the input.

### Applications Information

#### Input Considerations

Use 0.1 $\mu$ F ceramic capacitors to AC-couple the input. The input cannot be DC-coupled. The input capacitor stores a DC level so that the video signal is clamped to an appropriate DC voltage for proper sync detection.

#### Power-Supply Bypassing

Careful PC board layout is important for optimal system performance. Do not use wire-wrapped boards or breadboards. When possible, use a multilayer board with a dedicated low-inductance ground plane and supply plane. Connect all GND inputs to a single ground plane and V<sub>CC</sub> to a single-supply plane. Bypass V<sub>CC</sub> to GND with a 0.1 $\mu$ F capacitor.

#### Wired-OR Application

The  $\overline{\text{LOS}}$  open-drain output allows the MAX7461 to be used in wired-OR applications as shown in the typical application diagram of Figure 1.

### Chip Information

PROCESS: BiCMOS

# MAX7461

## Loss-of-Sync Alarm

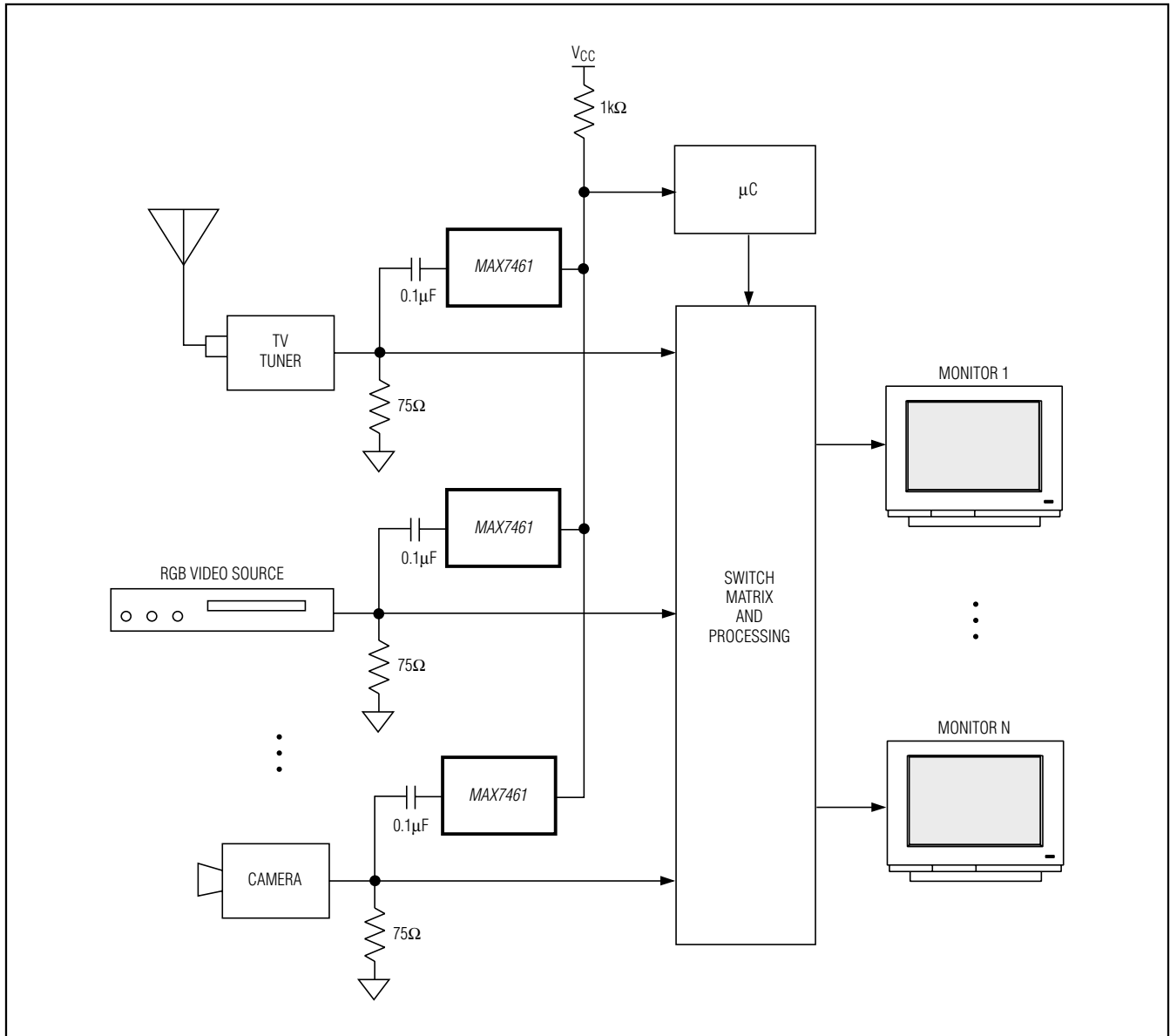

Figure 1. Wired-OR System

# MAX7461

## Loss-of-Sync Alarm

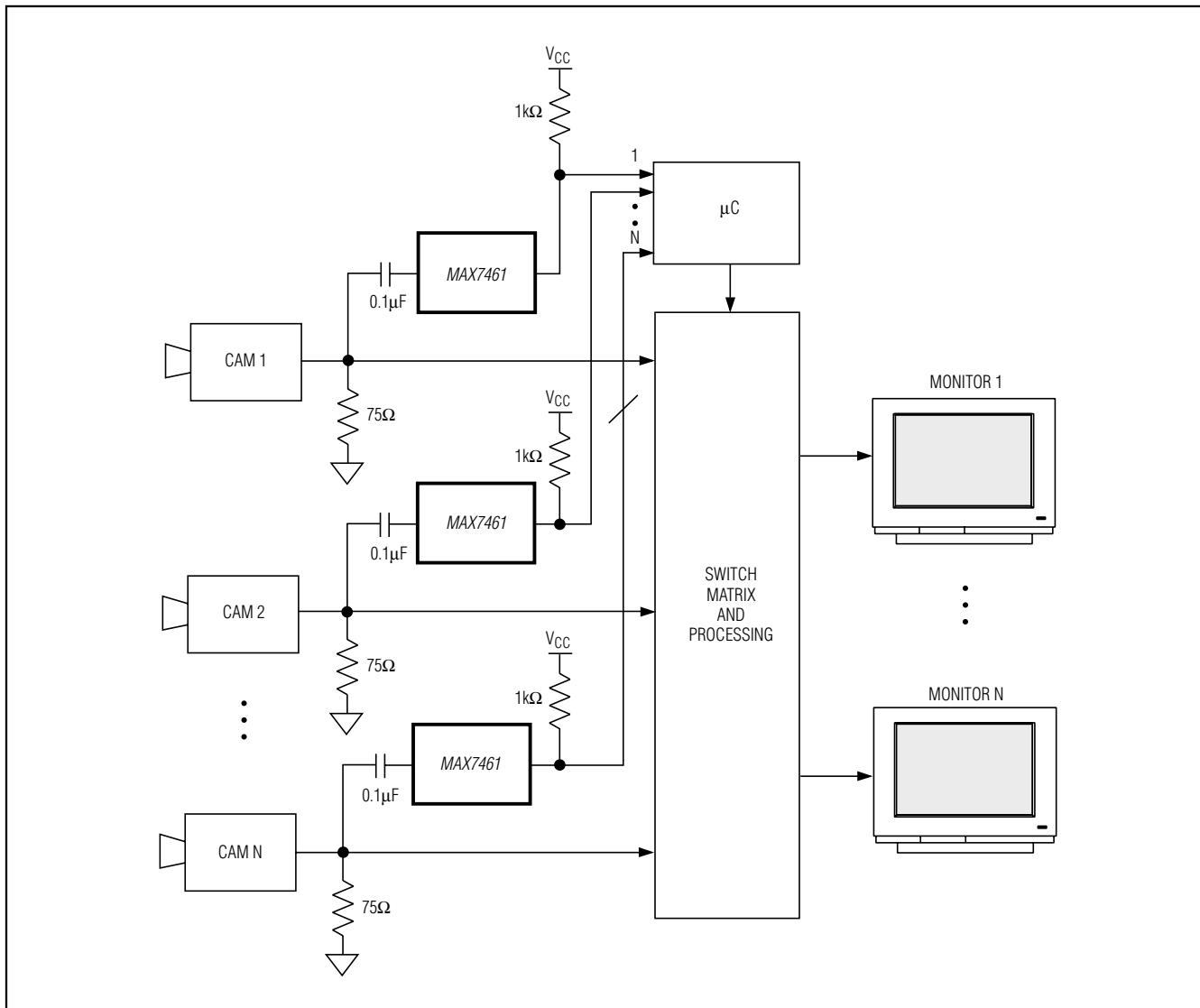

Figure 2. Video Security System

### Package Information

For the latest package outline information and land patterns (footprints), go to [www.maximintegrated.com/packages](http://www.maximintegrated.com/packages). Note that a "+", "#", or "-" in the package code indicates RoHS status only. Package drawings may show a different suffix character, but the drawing pertains to the package regardless of RoHS status.

PACKAGE TYPE	PACKAGE CODE	OUTLINE NO.	LAND PATTERN NO.
5 SOT23	U5-2	<a href="#">21-0057</a>	<a href="#">90-0174</a>

# MAX7461

## Loss-of-Sync Alarm

### Revision History

REVISION NUMBER	REVISION DATE	DESCRIPTION	PAGES CHANGED
0	6/00	Initial release	—
1	4/13	Removed references for automotive applications	1, 4, 5



Maxim Integrated cannot assume responsibility for use of any circuitry other than circuitry entirely embodied in a Maxim Integrated product. No circuit patent licenses are implied. Maxim Integrated reserves the right to change the circuitry and specifications without notice at any time. The parametric values (min and max limits) shown in the Electrical Characteristics table are guaranteed. Other parametric values quoted in this data sheet are provided for guidance.

**Maxim Integrated 160 Rio Robles, San Jose, CA 95134 USA 1-408-601-1000**

**7**

Компания «Life Electronics» занимается поставками электронных компонентов импортного и отечественного производства от производителей и со складов крупных дистрибьюторов Европы, Америки и Азии.

С конца 2013 года компания активно расширяет линейку поставок компонентов по направлению коаксиальный кабель, кварцевые генераторы и конденсаторы (керамические, пленочные, электролитические), за счёт заключения дистрибьюторских договоров

Мы предлагаем:

- Конкурентоспособные цены и скидки постоянным клиентам.
- Специальные условия для постоянных клиентов.
- Подбор аналогов.
- Поставку компонентов в любых объемах, удовлетворяющих вашим потребностям.
- Приемлемые сроки поставки, возможна ускоренная поставка.
- Доставку товара в любую точку России и стран СНГ.
- Комплексную поставку.
- Работу по проектам и поставку образцов.
- Формирование склада под заказчика.
- Сертификаты соответствия на поставляемую продукцию (по желанию клиента).
- Тестирование поставляемой продукции.
- Поставку компонентов, требующих военную и космическую приемку.
- Входной контроль качества.
- Наличие сертификата ISO.

В составе нашей компании организован Конструкторский отдел, призванный помогать разработчикам, и инженерам.

Конструкторский отдел помогает осуществить:

- Регистрацию проекта у производителя компонентов.
- Техническую поддержку проекта.
- Защиту от снятия компонента с производства.
- Оценку стоимости проекта по компонентам.
- Изготовление тестовой платы монтаж и пусконаладочные работы.



Тел: +7 (812) 336 43 04 (многоканальный)  
Email: [org@lifeelectronics.ru](mailto:org@lifeelectronics.ru)