

MAX9617 Evaluation Kit

Evaluates: MAX9617

General Description

The MAX9617 evaluation kit (EV kit) provides a proven design to evaluate the MAX9617 low-power, zero-drift operational amplifier (op amp) in a 6-pin SC70 package. The EV kit circuit is preconfigured as a noninverting amplifier, but can easily be adapted to other topologies by changing a few components. Low power, zero drift, input offset voltage, and rail-to-rail input/output stages make this device ideal for a variety of low-frequency measurement applications. The component pads accommodate 0805 packages, making them easy to solder and replace. The MAX9617 EV kit comes with a MAX9617AXT+ installed.

Features

- ◆ Accommodates Multiple Op-Amp Configurations
- ◆ Component Pads Allow for Sallen-Key Filter
- ◆ Rail-to-Rail Inputs/Outputs
- ◆ Accommodates Easy-to-Use 0805 Components
- ◆ Proven PCB Layout
- ◆ Fully Assembled and Tested

Ordering Information

PART	TYPE
MAX9617EVKIT+	EV Kit

+Denotes lead(Pb)-free and RoHS compliant.

Component List

DESIGNATION	QTY	DESCRIPTION
C1, C3	2	0.1 μ F \pm 10%, 25V X7R ceramic capacitors (0805) Murata GRM21BR71E104K
C2, C4	2	4.7 μ F \pm 10%, 25V X5R ceramic capacitors (0805) Murata GRM21BR61E475K
C5–C10	0	Not installed, ceramic capacitors (0805)
R1, R2	2	1k Ω \pm 1% resistors (0805)
R3, R4, R7	0	Not installed, resistors (0805)
R5	1	10k Ω \pm 1% resistor (0805)
R6, R8	2	0 Ω \pm 5% resistors (0805)
JU1, JU2, JU4	3	2-pin headers

DESIGNATION	QTY	DESCRIPTION
JU3, JU5	2	3-pin headers
TP1, TP3, TP5, TP6, TP7	5	Red multipurpose test points
TP2, TP4	2	Black multipurpose test points
TP8	0	Not installed, miniature test point
U1	1	Single low-power, rail-to-rail I/O op amp (6 SC70) Maxim MAX9617AXT+
—	5	Shunts
—	1	PCB: MAX9617 EVALUATION KIT+

Component Supplier

SUPPLIER	PHONE	WEBSITE
Murata Electronics North America, Inc.	770-436-1300	www.murata-northamerica.com

Note: Indicate that you are using the MAX9617 when contacting this component supplier.

MAX9617 Evaluation Kit

Evaluates: MAX9617

Quick Start

Required Equipment

- MAX9617 EV kit
- +5V, 10mA DC power supply (PS1)
- Precision voltage source
- Digital multimeter (DMM)

Procedure

The MAX9617 EV kit is fully assembled and tested. Follow the steps below to verify board operation:

- 1) Verify that the jumpers are in their default position, as shown in Table 1.
- 2) Connect the positive terminal of the +5V supply to VDD (TP1) and the negative terminal to GND (TP2) and VSS (TP3).
- 3) Connect the positive terminal of the precision voltage source to INP (TP6). Connect the negative terminal of the precision voltage source to GND (TP2 or TP4).
- 4) Connect INM (TP5) to GND.
- 5) Connect the DMM to monitor the voltage on OUTA (TP7). With the 10k Ω feedback resistor (R5) and 1k Ω series resistor (R1), the gain is +11 (noninverting configuration).
- 6) Turn on the +5V power supply.
- 7) Apply 100mV from the precision voltage source. Observe the output at OUTA (TP7) on the DMM. OUTA should read approximately +1.1V.
- 8) Apply 400mV from the precision voltage source. OUTA should read approximately +4.4V.

Table 1. MAX9617 EV Kit Jumper Descriptions (JU1–JU5)

JUMPER	SHUNT POSITION	DESCRIPTION
JU1	1-2*	Connects IN- to R1. Also shorts capacitor C5.
	Open	Connects IN- to R1 through capacitor C5. When AC-coupling is desired, remove the shunt and install capacitor C5.
JU2	1-2*	Connects IN+ to JU3 position 1. Also shorts capacitor C6.
	Open	Connects IN+ to JU3 position 1 through capacitor C6. When AC-coupling is desired, remove the shunt and install capacitor C6.
JU3	1-2*	Connects IN+ to INP (TP6) through R2 and R8
	2-3	Connects IN+ to GND through R2 and R8
JU4	1-2*	Connects OUT to OUTA (TP7)
	Open	Connects OUT to OUTA (TP7) through capacitor C10. When AC-coupling is desired, remove the shunt and install capacitor C10.
JU5	1-2*	Always keep jumper in this position (normal operation)
	2-3	Do not use this jumper position

*Default position.

Detailed Description of Hardware

The MAX9617 EV kit provides a proven layout for the MAX9617 low-power, zero-drift operational amplifier (op amp). The MAX9617 is a single-supply op amp that is ideal for buffering low-frequency sensor signals. The Sallen-Key topology is easily accomplished by changing and removing a few components. The Sallen-Key topology is ideal for buffering and filtering sensor signals. Various test points are included for easy evaluation.

The MAX9617 is a single-supply op amp whose primary application is operating in the noninverting configuration;

however, the MAX9617 can operate with a dual supply as long as the voltage across the VDD and GND pins of the IC do not exceed the *Absolute Maximum Ratings*. When operating with a single supply, short VSS to GND.

Op-Amp Configurations

The MAX9617 is a single-supply op amp that is ideal for differential sensing, noninverting amplification, buffering, and filtering. A few common configurations are shown in the next few sections.

MAX9617 Evaluation Kit

Evaluates: MAX9617

Noninverting Configuration

The MAX9617 EV kit comes preconfigured as a noninverting amplifier. The gain is set by the ratio of R5 and R1. The MAX9617 EV kit comes preconfigured for a gain of 11. The output voltage for the noninverting configuration is given by the equation below:

$$V_{OUT} = \left(1 + \frac{R5}{R1}\right) V_{INP}$$

Differential Amplifier

To configure the MAX9617 EV kit as a differential amplifier, replace R1, R2, R3, and R5 with appropriate resistors. When R1 = R2 and R3 = R5, the CMRR of the differential amplifier is determined by the matching of the resistor ratios R1/R2 and R3/R5.

$$V_{OUT} = GAIN(V_{INP} - V_{INM})$$

where:

$$GAIN = \frac{R5}{R1} = \frac{R3}{R2}$$

Sallen-Key Configuration

The Sallen-Key topology is ideal for filtering sensor signals with a second-order filter and acting as a buffer. Schematic complexity is reduced by combining the filter and buffer operations. The MAX9617 EV kit can be configured in a Sallen-Key topology by replacing and populating a few components. The Sallen-Key topology can be configured as a unity-gain buffer by replacing R1 and R5 with 0Ω resistors. The signal is noninverting and applied to INP. The filter component pads are R2,

R3, R4, and R8, where some have to be populated with resistors and others with capacitors.

Lowpass Sallen-Key Filter: To configure the Sallen-Key as a lowpass filter, populate the R2 and R8 pads with resistors and populate the R3 and R4 pads with capacitors. The corner frequency and Q are then given by:

$$f_c = \frac{1}{2\pi\sqrt{R_{R2}R_{R8}C_{R3}C_{R4}}}$$

$$Q = \frac{\sqrt{R_{R2}R_{R8}C_{R3}C_{R4}}}{C_{R4}(R_{R2} + R_{R8})}$$

Highpass Sallen-Key Filter: To configure the Sallen-Key as a highpass filter, populate the R3 and R4 pads with resistors and populate the R2 and R8 pads with capacitors. The corner frequency and Q are then given by:

$$f_c = \frac{1}{2\pi\sqrt{R_{R3}R_{R4}C_{R2}C_{R8}}}$$

$$Q = \frac{\sqrt{R_{R3}R_{R4}C_{R2}C_{R8}}}{R_{R3}(C_{R2} + C_{R8})}$$

Capacitive Loads

Some applications require driving large capacitive loads. To improve the stability of the amplifier in such cases, replace R6 with a suitable resistor value to improve amplifier phase margin.

MAX9617 Evaluation Kit

Evaluates: MAX9617

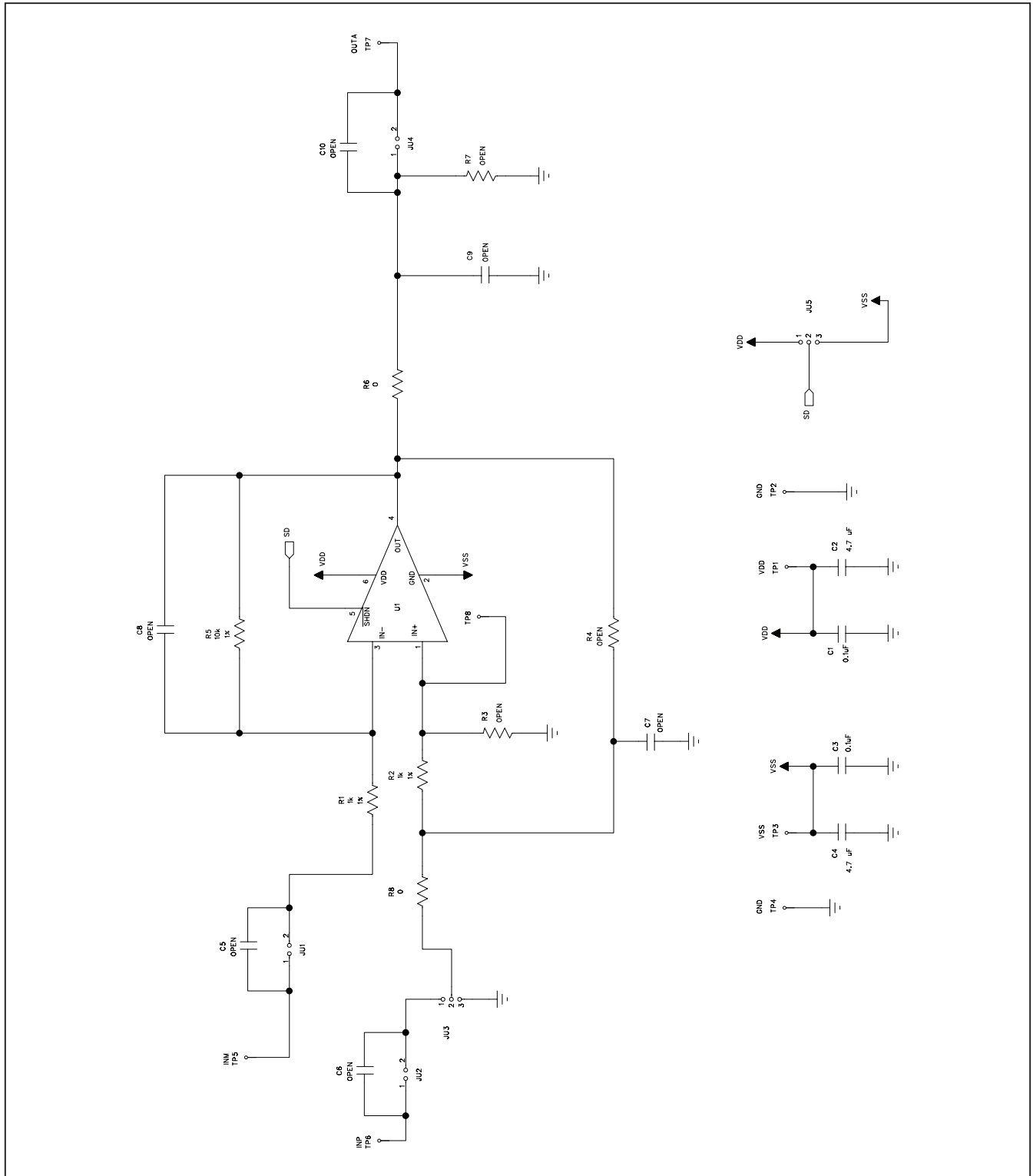

Figure 1. MAX9617 EV Kit Schematic

MAX9617 Evaluation Kit

Evaluates: MAX9617

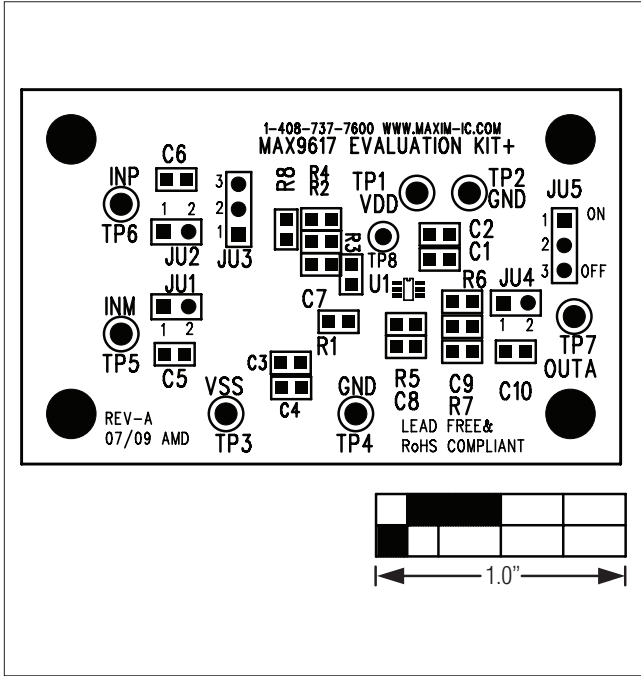

Figure 2. MAX9617 EV Kit Component Placement Guide—Component Side

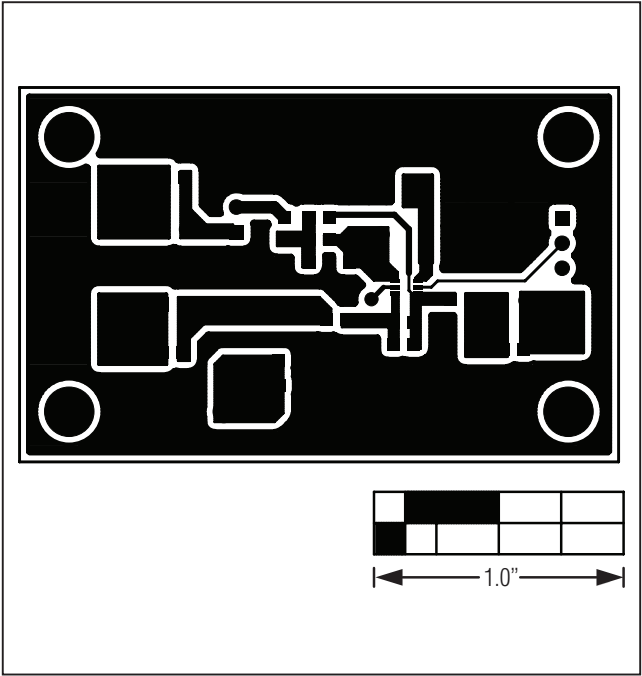

Figure 3. MAX9617 EV Kit PCB Layout—Component Side

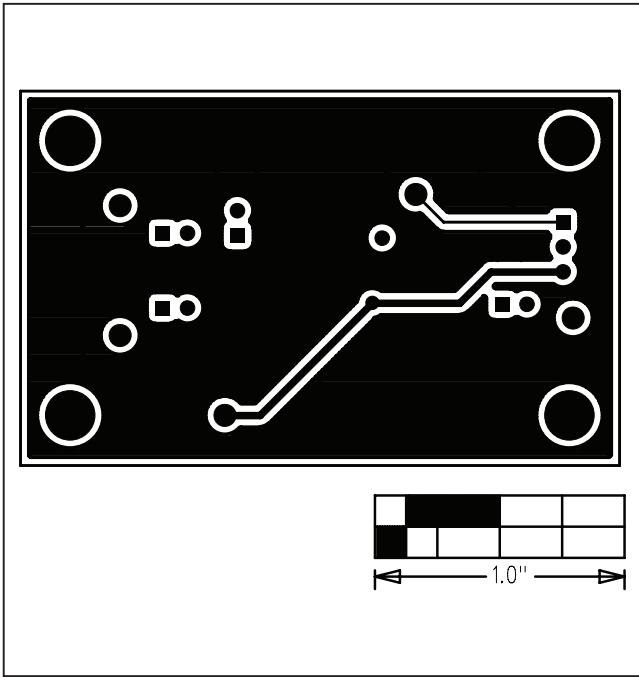

Figure 4. MAX9617 EV Kit PCB Layout—Solder Side

MAX9617 Evaluation Kit

Evaluates: MAX9617



Maxim Integrated cannot assume responsibility for use of any circuitry other than circuitry entirely embodied in a Maxim Integrated product. No circuit patent licenses are implied. Maxim Integrated reserves the right to change the circuitry and specifications without notice at any time. The parametric values (min and max limits) shown in the Electrical Characteristics table are guaranteed. Other parametric values quoted in this data sheet are provided for guidance.

Компания «Life Electronics» занимается поставками электронных компонентов импортного и отечественного производства от производителей и со складов крупных дистрибьюторов Европы, Америки и Азии.

С конца 2013 года компания активно расширяет линейку поставок компонентов по направлению коаксиальный кабель, кварцевые генераторы и конденсаторы (керамические, пленочные, электролитические), за счёт заключения дистрибьюторских договоров

Мы предлагаем:

- Конкурентоспособные цены и скидки постоянным клиентам.
- Специальные условия для постоянных клиентов.
- Подбор аналогов.
- Поставку компонентов в любых объемах, удовлетворяющих вашим потребностям.
- Приемлемые сроки поставки, возможна ускоренная поставка.
- Доставку товара в любую точку России и стран СНГ.
- Комплексную поставку.
- Работу по проектам и поставку образцов.
- Формирование склада под заказчика.
- Сертификаты соответствия на поставляемую продукцию (по желанию клиента).
- Тестирование поставляемой продукции.
- Поставку компонентов, требующих военную и космическую приемку.
- Входной контроль качества.
- Наличие сертификата ISO.

В составе нашей компании организован Конструкторский отдел, призванный помогать разработчикам, и инженерам.

Конструкторский отдел помогает осуществить:

- Регистрацию проекта у производителя компонентов.
- Техническую поддержку проекта.
- Защиту от снятия компонента с производства.
- Оценку стоимости проекта по компонентам.
- Изготовление тестовой платы монтаж и пусконаладочные работы.



Тел: +7 (812) 336 43 04 (многоканальный)

Email: org@lifeelectronics.ru