

CAT874

Smart Phone Battery Switch Controller

Description

CAT874 is a switch controller designed to start/shut-off smart phones with the push button input or by phone microcontroller unit.

CAT874 monitors two inputs and outputs an active high output after PWR_ON input has been active (logic low) for a factory preset minimum time. Releasing input from its active state before the minimum timeout period resets the internal timer and must return to being active before the timer will restart with a fresh count down. The output remains high until the next PWR_ON high-to-low or V_{CHG} low-to-high transition.

CAT874's push pull output is capable of sinking up to 3 mA of current.

Features

- Operate on 1.8 V to 5.5 V Power Supplies
- Ultra Low Quiescent Current: 100 nA (typical)
- Schmitt Trigger Inputs
- Small μ LLGA-6 Package: 1.45 x 1.0 x 0.4 mm
- These Devices are Pb-Free, Halogen Free/BFR Free and are RoHS Compliant

Typical Applications

- Mobile Phones
- PDAs
- MP3 Players
- Personal Navigation Devices

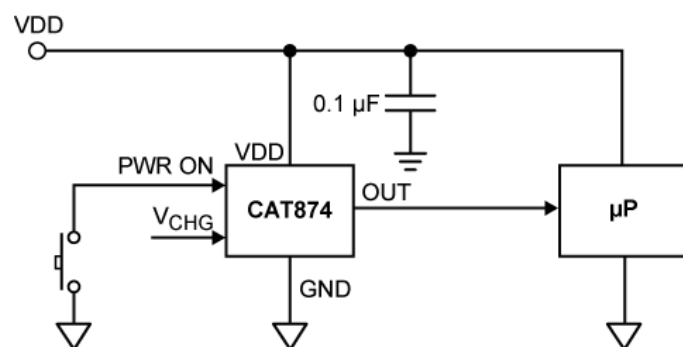
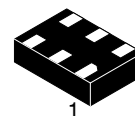

Figure 1. Application Schematic



ON Semiconductor®

<http://onsemi.com>



ULLGA-6
UL SUFFIX
CASE 613AF

MARKING DIAGRAM

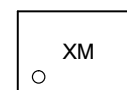

X = Specific Device Code
(d = CAT874)
M = Date Code

"P" written at 180° clockwise rotation

PIN CONNECTIONS

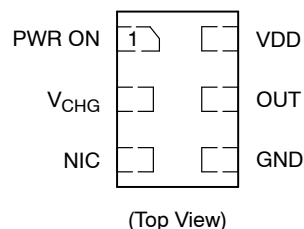

ORDERING INFORMATION

See detailed ordering and shipping information in the package dimensions section on page 7 of this data sheet.

CAT874

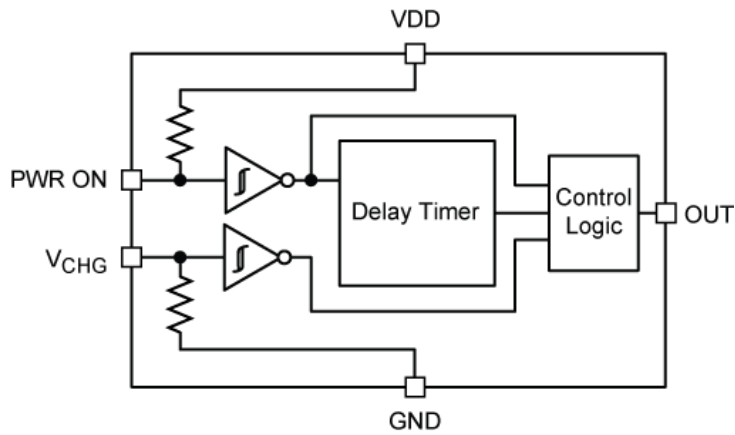

Figure 2. Functional Block Diagram

Table 1. PIN FUNCTION DESCRIPTION

Pin No.	Pin Name	Description
1	PWR_ON	Power ON, CMOS input.
2	V _{CHG}	Charger IN, CMOS input.
3	NIC	No Internal Connection. A voltage or signal applied to this pin will have no effect on device operation.
4	GND	System Ground.
5	OUT	Drive Output. Active-high push-pull output.
6	VDD	Positive Power Supply.

Table 2. ABSOLUTE MAXIMUM RATINGS

Rating	Symbol	Value	Unit
Input Voltage Range	V _{DD}	-0.3 to 6	V
Output Voltage Range	V _{OUT}	-0.3 to 6 or (V _{DD} + 0.3), whichever is lower	V
Input Voltage; PWR_ON, V _{CHG}	V _{IN}	-0.3 to 6 or (V _{DD} + 0.3), whichever is lower	V
Maximum Junction Temperature	T _{J(max)}	150	°C
Output Current; OUT	I _{OUT}	10	mA
Storage Temperature Range	T _{STG}	-65 to 150	°C
ESD Capability, Human Body Model (Note 1)	ESD _{HBM}	2	kV
ESD Capability, Machine Model (Note 2)	ESD _{MM}	150	V
Lead Temperature Soldering Reflow (SMD Styles Only), Pb-Free Versions (Note 2)	T _{SLD}	260	°C

Stresses exceeding Maximum Ratings may damage the device. Maximum Ratings are stress ratings only. Functional operation above the Recommended Operating Conditions is not implied. Extended exposure to stresses above the Recommended Operating Conditions may affect device reliability.

- This device series incorporates ESD protection and is tested by the following methods:
 ESD Human Body Model tested per AEC-Q100-002 (EIA/JESD22-A114)
 ESD Machine Model tested per AEC-Q100-003 (EIA/JESD22-A115)
 Latch-up Current Maximum Rating: ≤150 mA per JEDEC standard: JESD78
- For information, please refer to our Soldering and Mounting Techniques Reference Manual, SOLDERRM/D

Table 3. RECOMMENDED OPERATING CONDITIONS

Rating	Symbol	Min	Max	Unit
Input Voltage; VDD	V _{DD}	1.8	5.5	V
Input Voltage; PWR_ON, V _{CHG}	V _{IN}	0	V _{DD}	V
Output Current; OUT	I _{OUT}	0	3	mA
Ambient Temperature	T _A	-40	85	°C

CAT874

Table 4. ELECTRICAL OPERATING CHARACTERISTICS

($V_{DD} = 1.8\text{ V}$ to 5.5 V . For typical values $T_A = 25^\circ\text{C}$, for min/max values $T_A = -40^\circ\text{C}$ to $+85^\circ\text{C}$ unless otherwise noted.)

Parameter	Test Conditions	Symbol	Min	Typ	Max	Unit
POWER						
V_{DD} Supply Voltage		V_{DD}	1.8		5.5	V
Quiescent Supply Current	$PWR_ON = V_{DD}$, $V_{CHG} = 0\text{ V}$	I_{DD}		100	1000	nA
Operating Supply Current	$PWR_ON = 0\text{ V}$, $V_{CHG} = 0\text{ V}$ Measured during setup period. Measurement includes current through internal $200\text{ k}\Omega$ pull-up resistor on PWR_ON				50	μA

LOGIC INPUTS AND OUTPUTS

Input Voltage; HIGH	PWR_ON , V_{CHG}	V_{IH}	$0.7 \times V_{DD}$			V
Input Voltage; LOW	PWR_ON , V_{CHG}	V_{IL}			$0.25 \times V_{DD}$	V
Hysteresis		V_{HYS}		250		mV
Input Current V_{CHG}	$V_{CHG} = 0\text{ V}$; $V_{DD} = 5\text{ V}$ (internal pull-down)	I_{IL1}		50	300	nA
Input Current V_{CHG}	$V_{CHG} = 5\text{ V}$; $V_{DD} = 5\text{ V}$ (internal pull-down)	I_{IH1}		25		μA
Input Current PWR_ON	$PWR_ON = 0\text{ V}$; $V_{DD} = 5\text{ V}$ (internal $200\text{ k}\Omega$ pull-up resistor)	I_{IL2}		25		μA
Input Current PWR_ON	$PWR_ON = 5\text{ V}$; $V_{DD} = 5\text{ V}$ (internal $200\text{ k}\Omega$ pull-up resistor)	I_{IH2}		50	300	nA
Output Voltage; HIGH	$I_{SOURCE} = -0.1\text{ mA}$, $V_{DD} = 1.8\text{ V}$	V_{OH}	$V_{DD} - 0.2$			V
Output Voltage; LOW	$I_{SINK} = 3\text{ mA}$, $V_{DD} = 1.8\text{ V}$	V_{OL}		0.1	0.4	V

TIMING

Input Delay PWR_ON	$T_A = 25^\circ\text{C}$	t_{low_delay}	6.56	8.00	9.44	s
	$T_A = -40^\circ\text{C}$ to $+85^\circ\text{C}$		6.00		10.00	

TEST MODE ($V_{DD} = 5\text{ V}$, $T_A = 25^\circ\text{C}$) (Note 3)

Start TEST Window		t_{ST}			35	μs
Test Mode Delay	$PWR_ON = 0\text{ V}$, $V_{CHG} \rightarrow 7$ cycles, delay measured after 8th rising edge of V_{CHG} clock pulse	t_D		250		μs
Test Mode Clock Frequency	Clock applied to V_{CHG}	f_{tm}		1		MHz
PWR_ON Test Mode Clock Setup Time	Measured from PWR_ON falling edge to first falling edge of V_{CHG}	t_P	1			μs
V_{CHG} Input Voltage; LOW	V_{CHG} , Test Mode Operation	V_{IL_TM}			$0.2 \times V_{DD}$	V
V_{CHG} Pulse Width		t_{pw}		500		ns

3. "Test Mode" parameters are not tested in production.

CAT874

TIMING WAVEFORMS

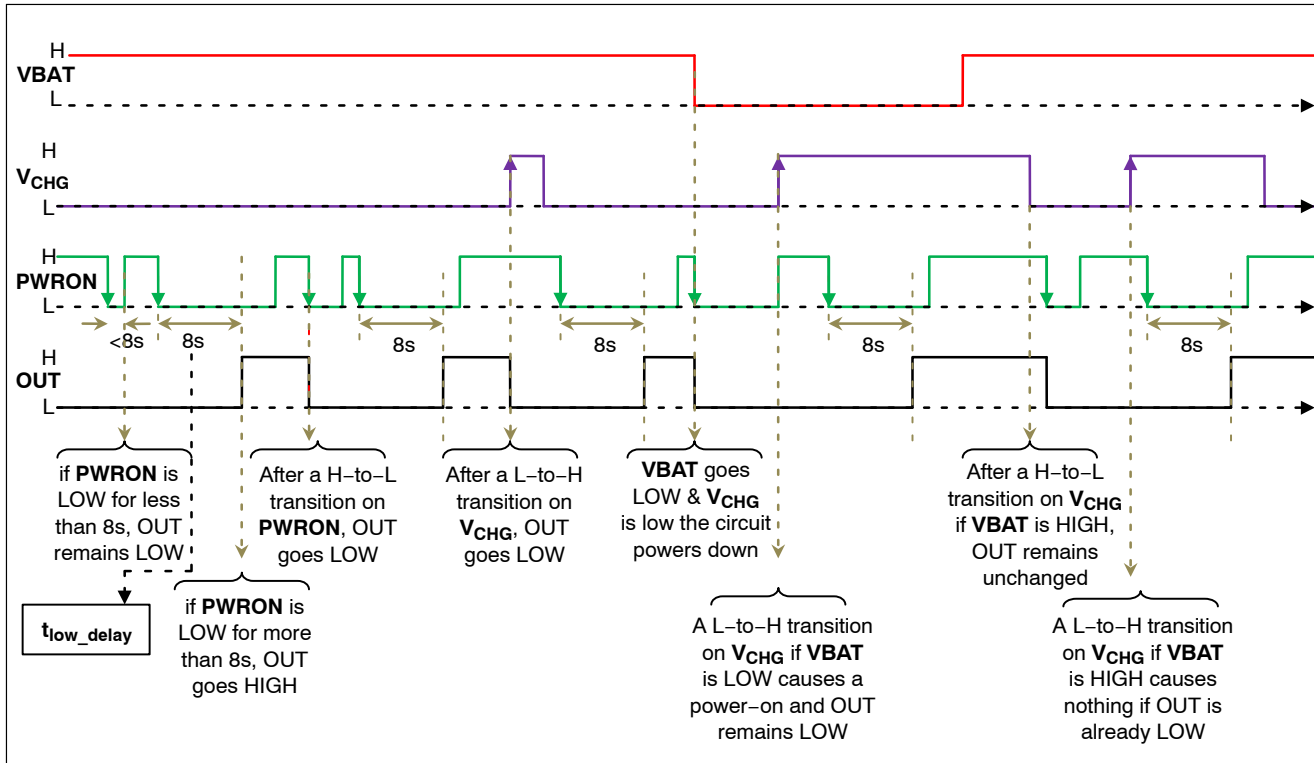

Figure 3. Timing Waveforms

CAT874

SYSTEM DESCRIPTION AND APPLICATIONS INFORMATION

General

CAT874 is designed for the manual switching of microprocessors and microcontrollers. To prevent accidental resets, CAT874 requires PWR_ON input be held low for a prescribed period before an Active high output is issued to the system processor.

PWR_ON and V_CHG Inputs

PWR_ON and V_CHG are Schmitt trigger CMOS inputs. PWR_ON must go low and stay low for a predetermined period (t_{LOW_DELAY}) to generate an Active high on the output.

V_CHG is a standard CMOS input with internal pull down resistor 200 k Ω to keep the input low when charger is not plugged in and PWR_ON is also a CMOS input with an internal 200 k Ω pull-up resistor, thus PWR_ON can be left floating.

When PWR_ON goes low, an internal timing cycle is initiated. If it goes high before the countdown timer has concluded its cycle, the timer will reset and will restart from the beginning when PWR_ON returns to being low.

Output (OUT)

CAT874 provides an active-high push pull output. This output will sink up to 3 mA.

Delay Timer Testing:

A user test mode is provided to reduce the system test time after the CAT874 is mounted on the board. Instead of waiting t_{LOW_DELAY} for the output to go active.

The user brings PWR_ON low, and sends seven positive edges on the V_CHG pin in a window of time t_{ST} . After a delay t_D , the device output will change state from low to high, and will return to the low state only when there is a high-to-low transition on PWR_ON.

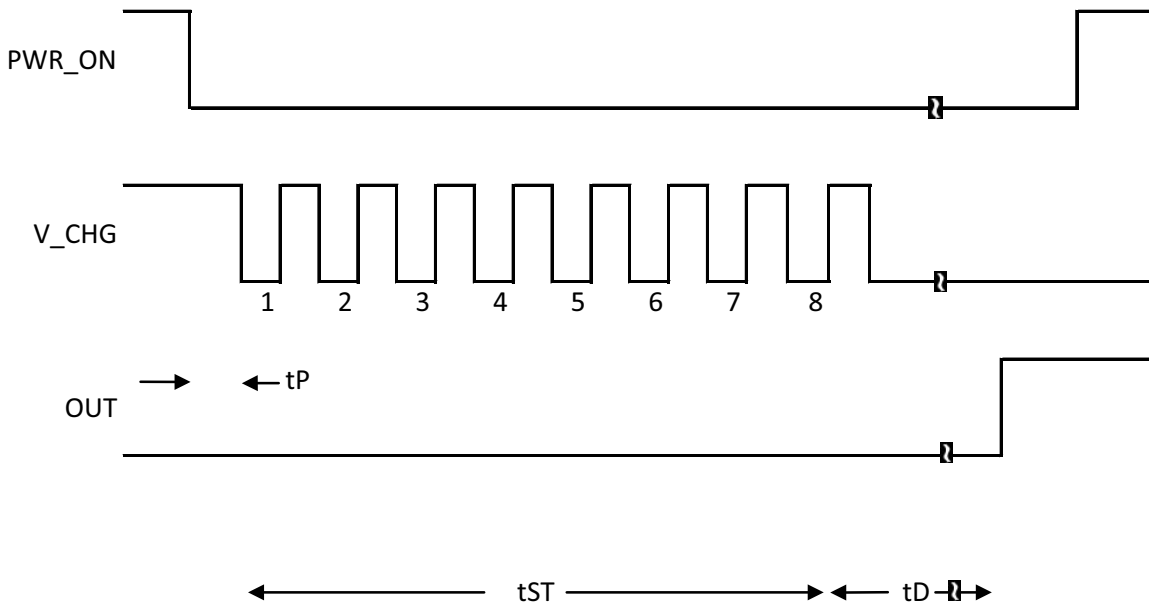

Figure 4. TOC Mode

CAT874

APPLICATION INFORMATION

Output Operation

System with Two Different Power Supply Voltages

When both V_{CHG} and V_{BAT} are present, the following application can be adapted. Schottky diodes D1 and D2 can be used to isolate the two sources. The higher source will supply the VDD power.

If V_{CHG} is not present then drop across D2 should be low enough to turn off Q1. If both V_{CHG} and V_{BAT} are present, the timing waveforms should be used as shown in Figure 4.

An external resistor 1M should be used OUT, to discharge the output when both sources turn off.

Operation with Low VDD Voltage and Brownout Condition

The CAT874 requires a minimum supply voltage VDD of 1.8 V to guarantee the normal operation within the specification. To prevent small VDD supply glitch, a small ceramic capacitor can be added between the VDD pin and GND.

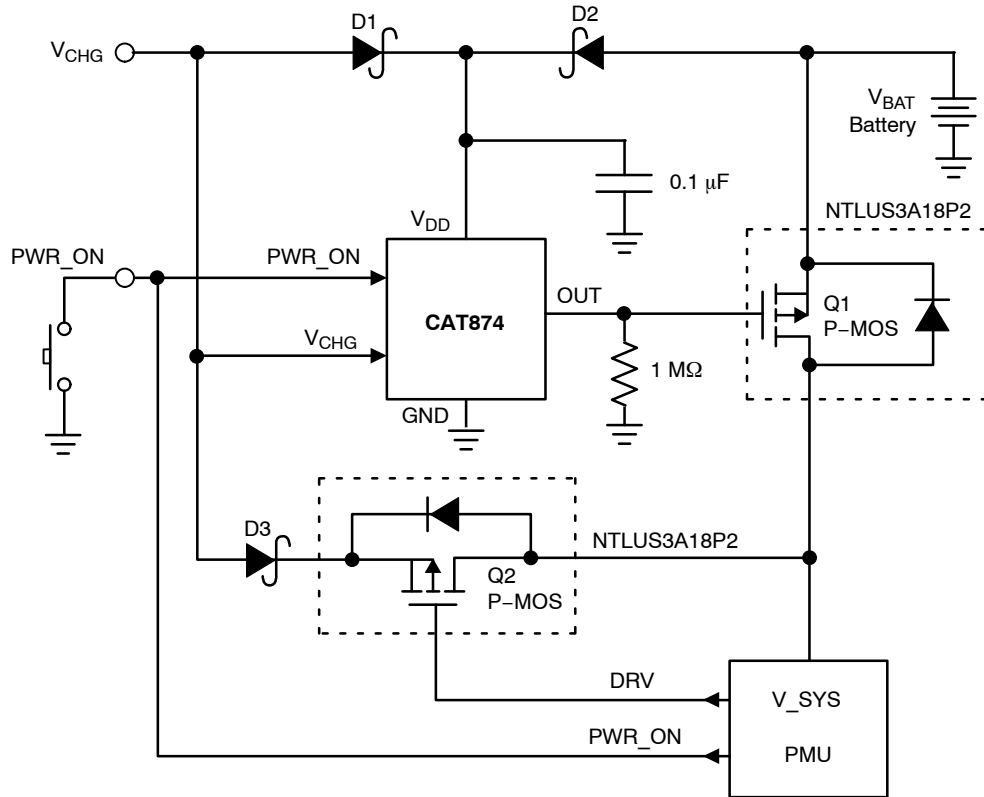
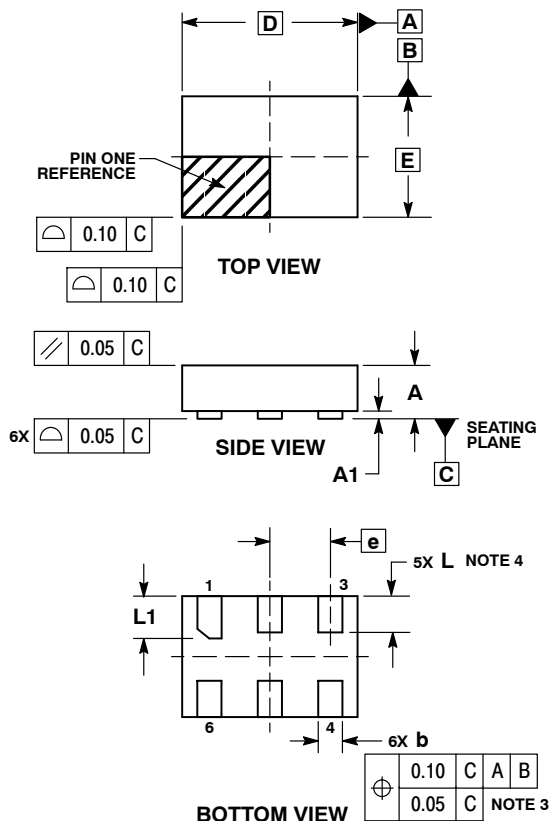

Figure 5. Application Schematic in Dual Supply System

CAT874

PACKAGE DIMENSIONS

ULLGA6, 1.45x1.0, 0.5P
CASE 613AF-01
ISSUE A



NOTES:

1. DIMENSIONING AND TOLERANCING PER ASME Y14.5M, 1994.
2. CONTROLLING DIMENSION: MILLIMETERS.
3. DIMENSION b APPLIES TO PLATED TERMINAL AND IS MEASURED BETWEEN 0.15 AND 0.30 mm FROM THE TERMINAL TIP.
4. A MAXIMUM OF 0.05 PULL BACK OF THE PLATED TERMINAL FROM THE EDGE OF THE PACKAGE IS ALLOWED.

MILLIMETERS		
DIM	MIN	MAX
A	---	0.40
A1	0.00	0.05
b	0.15	0.25
D	1.45 BSC	
E	1.00 BSC	
e	0.50 BSC	
L	0.25	0.35
L1	0.30	0.40

**MOUNTING FOOTPRINT
SOLDERMASK DEFINED***

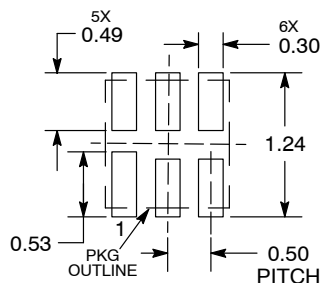

DIMENSIONS: MILLIMETERS

*For additional information on our Pb-Free strategy and soldering details, please download the ON Semiconductor Soldering and Mounting Techniques Reference Manual, SOLDERRM/D.

Table 5. ORDERING INFORMATION

Device	Timeout (s)	Marking	Package	Shipping (Note 4)
CAT874-80ULGT3	8	d M "P" written at 180° clockwise rotation	μLLGA-6	3,000 / Tape & Reel

4. For information on tape and reel specifications, including part orientation and tape sizes, please refer to our Tape and Reel Packaging Specifications Brochure, BRD8011/D.

ON Semiconductor and are registered trademarks of Semiconductor Components Industries, LLC (SCILLC). SCILLC owns the rights to a number of patents, trademarks, copyrights, trade secrets, and other intellectual property. A listing of SCILLC's product/patent coverage may be accessed at www.onsemi.com/site/pdf/Patent-Marketing.pdf. SCILLC reserves the right to make changes without further notice to any products herein. SCILLC makes no warranty, representation or guarantee regarding the suitability of its products for any particular purpose, nor does SCILLC assume any liability arising out of the application or use of any product or circuit, and specifically disclaims any and all liability, including without limitation special, consequential or incidental damages. "Typical" parameters which may be provided in SCILLC data sheets and/or specifications can and do vary in different applications and actual performance may vary over time. All operating parameters, including "Typicals" must be validated for each customer application by customer's technical experts. SCILLC does not convey any license under its patent rights nor the rights of others. SCILLC products are not designed, intended, or authorized for use as components in systems intended for surgical implant into the body, or other applications intended to support or sustain life, or for any other application in which the failure of the SCILLC product could create a situation where personal injury or death may occur. Should Buyer purchase or use SCILLC products for any such unintended or unauthorized application, Buyer shall indemnify and hold SCILLC and its officers, employees, subsidiaries, affiliates, and distributors harmless against all claims, costs, damages, and expenses, and reasonable attorney fees arising out of, directly or indirectly, any claim of personal injury or death associated with such unintended or unauthorized use, even if such claim alleges that SCILLC was negligent regarding the design or manufacture of the part. SCILLC is an Equal Opportunity/Affirmative Action Employer. This literature is subject to all applicable copyright laws and is not for resale in any manner.

PUBLICATION ORDERING INFORMATION

LITERATURE FULFILLMENT:
Literature Distribution Center for ON Semiconductor
P.O. Box 5163, Denver, Colorado 80217 USA
Phone: 303-675-2175 or 800-344-3860 Toll Free USA/Canada
Fax: 303-675-2176 or 800-344-3867 Toll Free USA/Canada
Email: orderlit@onsemi.com

N. American Technical Support: 800-282-9855 Toll Free
USA/Canada
Europe, Middle East and Africa Technical Support:
Phone: 421 33 790 2910
Japan Customer Focus Center
Phone: 81-3-5817-1050

ON Semiconductor Website: www.onsemi.com
Order Literature: <http://www.onsemi.com/orderlit>

For additional information, please contact your local Sales Representative

Компания «Life Electronics» занимается поставками электронных компонентов импортного и отечественного производства от производителей и со складов крупных дистрибьюторов Европы, Америки и Азии.

С конца 2013 года компания активно расширяет линейку поставок компонентов по направлению коаксиальный кабель, кварцевые генераторы и конденсаторы (керамические, пленочные, электролитические), за счёт заключения дистрибьюторских договоров

Мы предлагаем:

- Конкурентоспособные цены и скидки постоянным клиентам.
- Специальные условия для постоянных клиентов.
- Подбор аналогов.
- Поставку компонентов в любых объемах, удовлетворяющих вашим потребностям.
- Приемлемые сроки поставки, возможна ускоренная поставка.
- Доставку товара в любую точку России и стран СНГ.
- Комплексную поставку.
- Работу по проектам и поставку образцов.
- Формирование склада под заказчика.
- Сертификаты соответствия на поставляемую продукцию (по желанию клиента).
- Тестирование поставляемой продукции.
- Поставку компонентов, требующих военную и космическую приемку.
- Входной контроль качества.
- Наличие сертификата ISO.

В составе нашей компании организован Конструкторский отдел, призванный помогать разработчикам, и инженерам.

Конструкторский отдел помогает осуществить:

- Регистрацию проекта у производителя компонентов.
- Техническую поддержку проекта.
- Защиту от снятия компонента с производства.
- Оценку стоимости проекта по компонентам.
- Изготовление тестовой платы монтаж и пусконаладочные работы.



Тел: +7 (812) 336 43 04 (многоканальный)

Email: org@lifeelectronics.ru