

Hi-performance Regulator IC Series for PCs

PGOOD IC

for PC



BD4140HFV

No.09030EBT18

●Description

BD4140HFV is 1ch reset IC for watching the voltage. The detected voltage is 0.5V, and it is available to several kinds of voltage with additional external resistance. For the independent supply voltage (V_{CC}), the "L" level of voltage is guaranteed in case the watching input voltage is also low.

●Features

- 1) Open drain output type
- 2) Built in Under Voltage LockOut (UVLO) circuit
- 3) HVSO5 package : 1.6 × 1.6 × 0.6(mm)

●Applications

Laptop PC, Desktop PC, LCD-TV, Printer, STV, Digital appliances

●Absolute maximum ratings (Ta=25°C)

Parameter	Symbol	BD4140HFV	Unit
Terminal voltage	V _{CC} , IN, DLY, PGOOD	6 ^{*1}	V
Power Dissipation	P _d	0.67 ^{*2}	W
PGOOD Capacity Current	I _{PGOOD}	5	mA
Operating temperature range	T _{opr}	-10~+100	°C
Storage temperature range	T _{stg}	-55~+150	°C
Junction Temperature	T _{jmax}	+150	°C

*1 Do not however exceed P_d.

*2 Reduced by $\theta_{ja}=186.6^{\circ}\text{C/W}$ for increase in Ta of 1°C over 25°C.

(when mounted on a board 70.0mm × 70mm × 1.6mm Glass-epoxy PCB which has 1 layer. (copper foil density :2%))

*3 Reduced by $\theta_{ja}=185.2^{\circ}\text{C/W}$ for increase in Ta of 1°C over 25°C

(when mounted on a board 70.0mm × 70mm × 1.6mm Glass-epoxy PCB which has 1 layer.)

●Operating Conditions (Ta=25°C)

Parameter	Symbol	Min.	Max.	Unit
Terminal voltage	V _{CC}	3.0	5.5	V
	IN	-0.3	V _{CC} -2	V
	PGOOD	-0.3	5.5	V
	DLY	-0.3	V _{CC}	V

●ELECTRICAL CHARACTERISTICS (Unless otherwise noted, Ta=25°C, V_{CC}=5V)

Parameter	Symbol	Limits			Unit	Conditions
		Min.	Typ.	Max.		
Bias Current	I _{CC}	-	5	10	μA	-
Detected Voltage	V _{DET}	491	500	509	mV	IN sweep up
Hysteresis Voltage	V _{HYS}	-	10	-	mV	IN sweep down
Delay Current	I _{DLY}	150	250	350	nA	IN=0.6V
PGOOD Output ON Resistance	R _{VOUT}	-	100	200	Ω	IN=0V
PGOOD Output Leak Current	I _{OUT}	-	0	5	μA	IN=0.6V

●Block Diagram

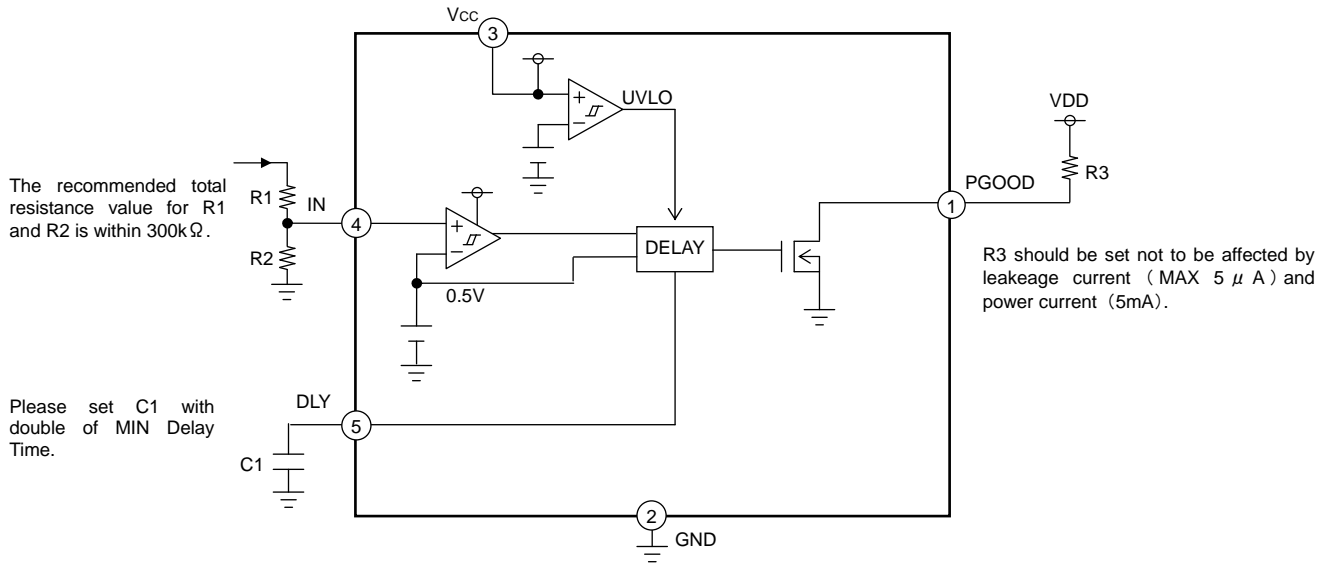

●Pin Layout

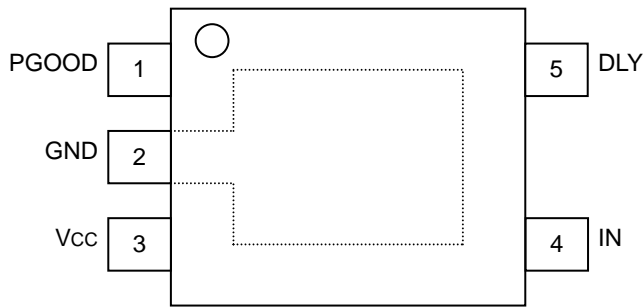

●Pin Function Table

PIN No.	PIN Name	PIN Function
1	PGOOD	Reset Output Pin (Power Good Signal)
2	GND	Ground Pin
3	Vcc	Power Supply Input Pin
4	IN	Watching Voltage Input Pin
5	DLY	Capacitor connected pin for setting delay time
Bottom	FIN	Substrate

●Explanation of Operation

BD4140HFV is 1ch reset IC with independent supply voltage.

The following voltage is available to input VCC voltage before the watching input voltage.

(Input-output voltage characteristic)

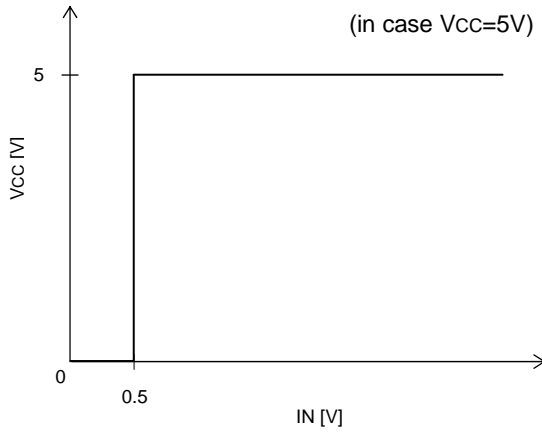

(Detected delay time setting)

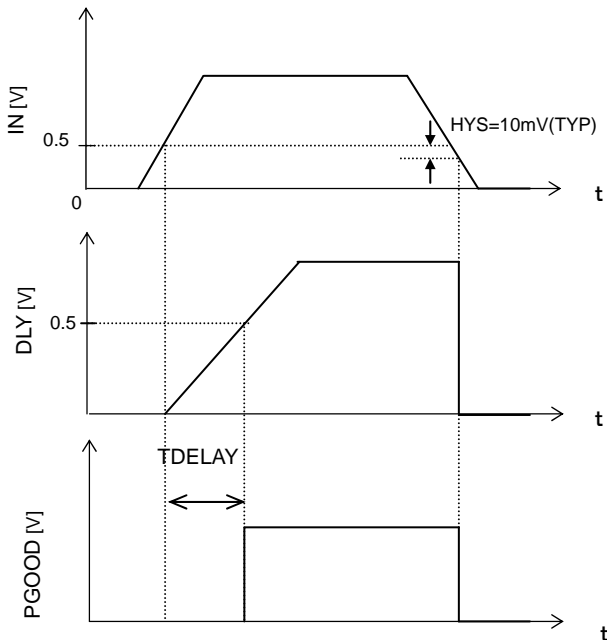

TDELAY is calculated with formula below.

$$T_{DELAY} [sec] = \frac{C_{EXT} [\mu F] \times 0.5}{0.25 [\mu A]}$$

$$= 2 \times C_{EXT}[pF] \times 10^{-6}$$

$$C_{EXT} [pF] = T_{DELAY} [sec] / (2 \times 10^{-6})$$

(Example) When using the 4700pF capacitor,

$$T_{DELAY} [sec] = 2 \times 4700 [pF] \times 10^{-6}$$

$$= 9400 \times 10^{-6} = 9.4 [ms]$$

(Example) When setting 2ms Delay,

$$C_{EXT} = 2 [ms] \times 0.25 [\mu A] / 0.5$$

$$= \frac{2 \times 10^{-3} \times 0.25 \times 10^{-6}}{0.5}$$

$$= 1 \times 10^{-9}$$

$$= 1000[pF]$$

<VCC starting>

- ① When VCC is below the minimum operation voltage, PGOOD pin will be at H level.
 (The meaning of the minimum operation voltage is : When the starting of VCC, PGOOD output voltage become within 10% of VCC voltage, and the value will be around 0.8VTYP(RPGOOD=100kΩ) and 1.0VTYP(RPGOOD=10kΩ). But note that this value is reference.)
- ② If VCC value exceeds the minimum operation voltage, by the VCC reached UVLO cancellation voltage (2.5V TYP), PGOOD output become at L level.
- ③ If VCC exceeds UVLO cancellation voltage, when the input voltage of IN pin is over the detected voltage, PGOOD pin will be at H level, and when the input voltage of IN pin is below the detected voltage, PGOOD pin will be at L level.

(PGOOD=OK)

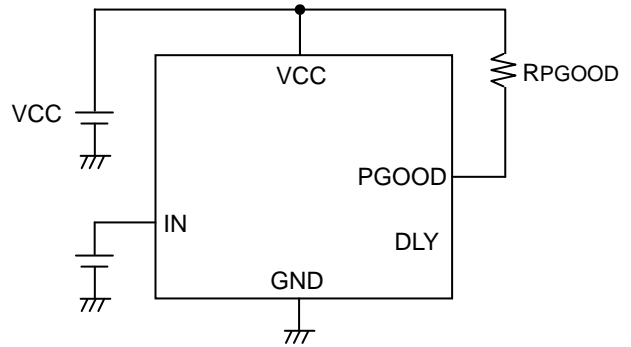
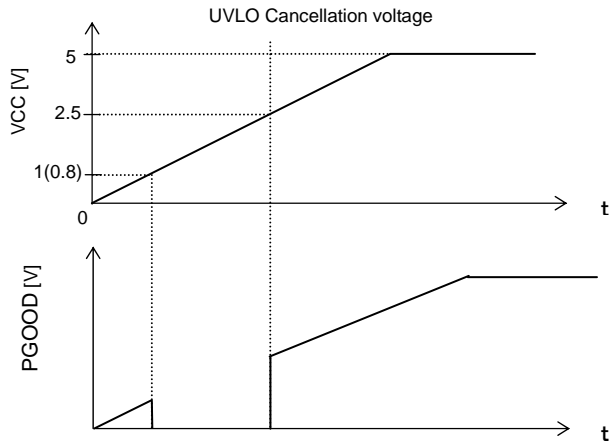

(PGOOD=NG)

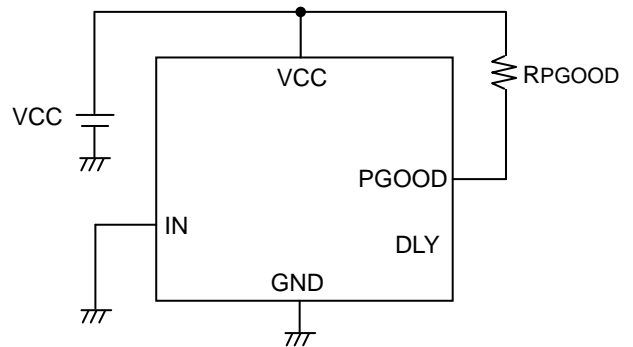
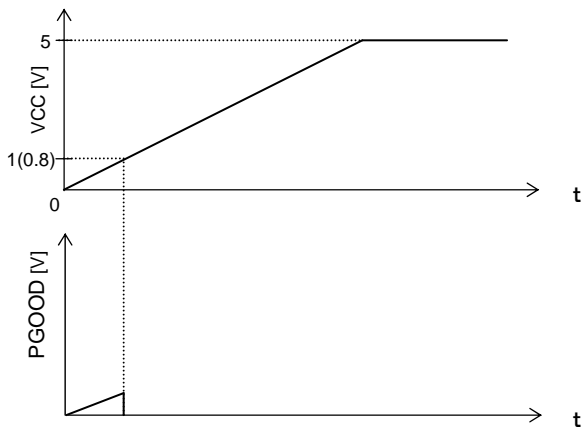

● Evaluation Board Circuit

■ BD4140HFV

(The direction is ※When you order, please order in times the amount of package quantity.)

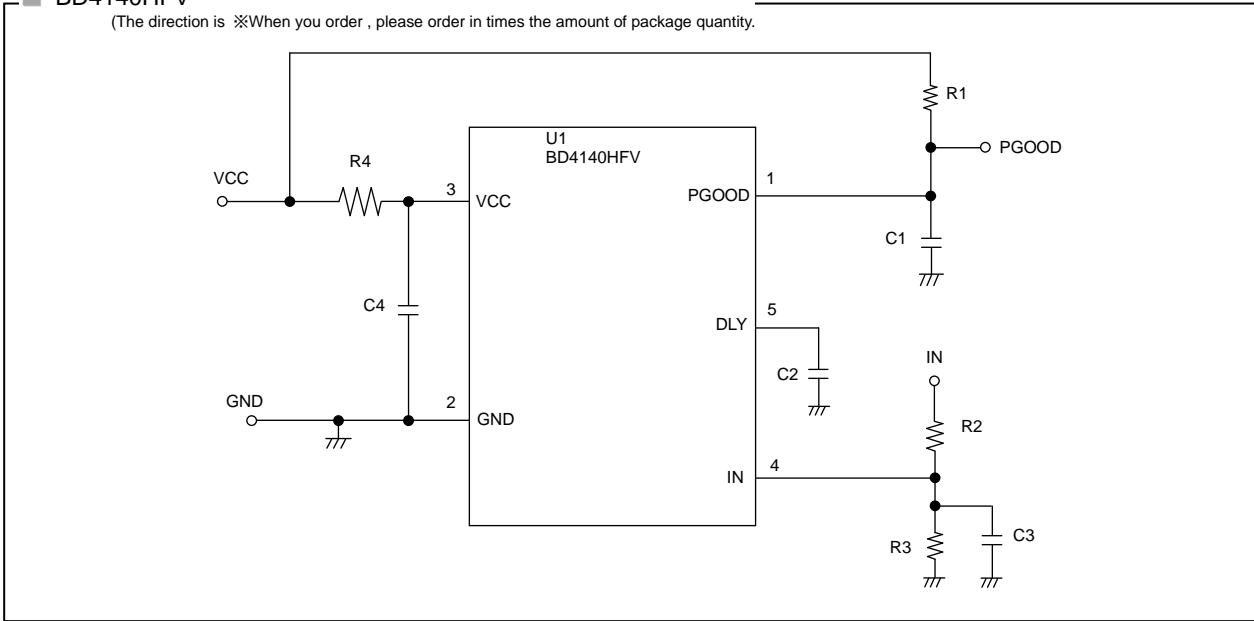

■ BD4140HFV Evaluation Board Standard Component List (at detecting 0.5V)

Component	Rating	Manufacturer	Product Name	Component	Rating	Manufacturer	Product Name
U1	-	ROHM	BD4140HFV	R1	100kΩ	ROHM	
C1	-	-	-	R2	0Ω	-	jumper
C2	1000pF	murata	GRM1552C1H102JA01	R3	-	-	-
C3	-	-	-	R4	0Ω	-	jumper
C4	-	-	-				

■ BD4140HFV Evaluation Board Layout

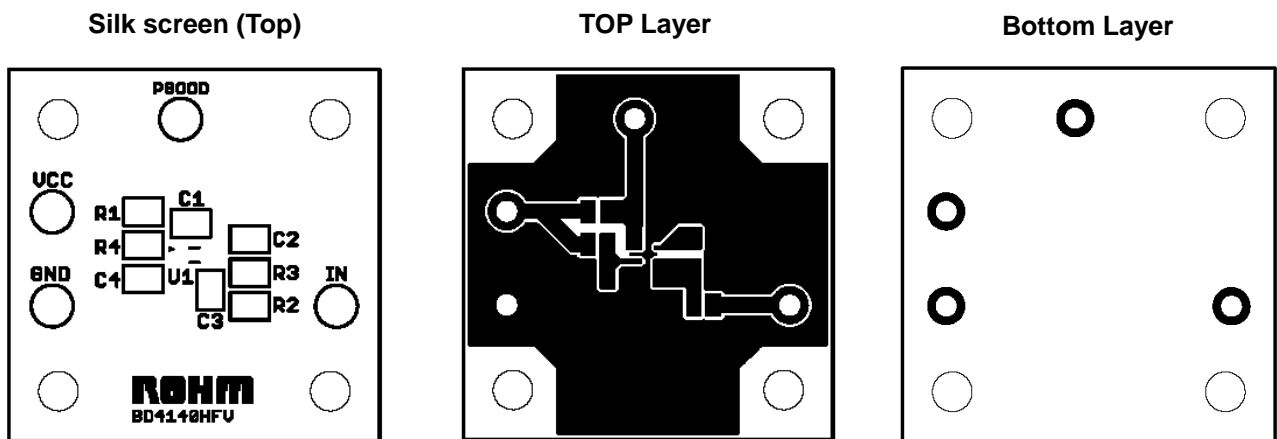

● Operation Notes

1. Absolute maximum ratings

An excess in the absolute maximum ratings, such as supply voltage, temperature range of operating conditions, etc., can break down the devices, thus making impossible to identify breaking mode, such as a short circuit or an open circuit. If any over rated values will expect to exceed the absolute maximum ratings, consider adding circuit protection devices, such as fuses.

2. Power supply lines

Please add a protection diode when a large inductance component is connected to the output terminal, and reverse-polarity protection is possible at startup or in output OFF condition.

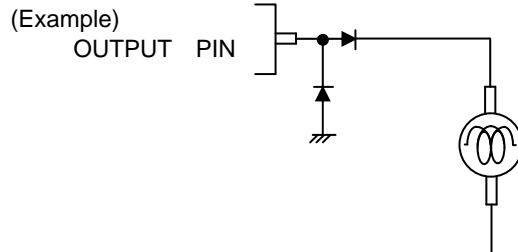

3. GND voltage

The potential of GND pin must be minimum potential in all operating conditions.

4. Inter-pin shorts and mounting errors

Use caution when positioning the IC for mounting on printed circuit boards. The IC may be damaged if there is any connection error or if pins are shorted together.

5. Actions in strong electromagnetic field

Use caution when using the IC in the presence of a strong electromagnetic field as doing so may cause the IC to malfunction.

6. Testing on application boards

When testing the IC on an application board, connecting a capacitor to a pin with low impedance subjects the IC to stress. Always discharge capacitors after each process or step. Always turn the IC's power supply off before connecting it to or removing it from a jig or fixture during the inspection process. Ground the IC during assembly steps as an antistatic measure. Use similar precaution when transporting or storing the IC.

7. Regarding input pin of the IC

This monolithic IC contains P+ isolation and P substrate layers between adjacent elements in order to keep them isolated. P-N junctions are formed at the intersection of these P layers with the N layers of other elements, creating a parasitic diode or transistor. For example, the relation between each potential is as follows:

When $GND > Pin A$ and $GND > Pin B$, the P-N junction operates as a parasitic diode.

When $GND > Pin B$, the P-N junction operates as a parasitic transistor.

Parasitic diodes can occur inevitable in the structure of the IC. The operation of parasitic diodes can result in mutual interference among circuits, operational faults, or physical damage. Accordingly, methods by which parasitic diodes operate, such as applying a voltage that is lower than the GND (P substrate) voltage to an input pin, should not be used.

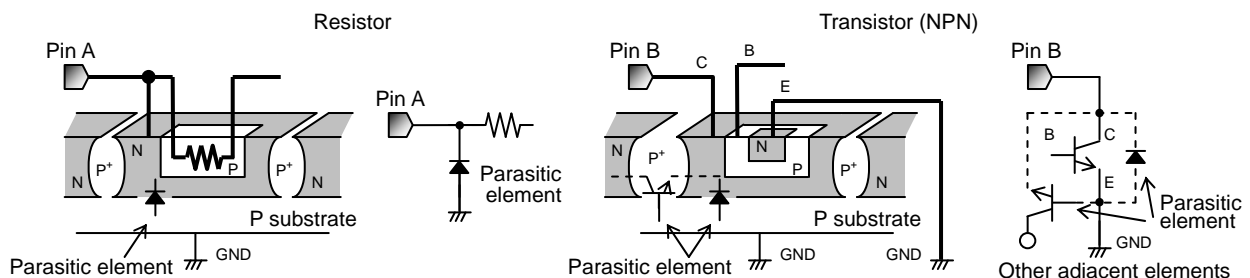

● Power Dissipation Characteristics

◎ HVSO5

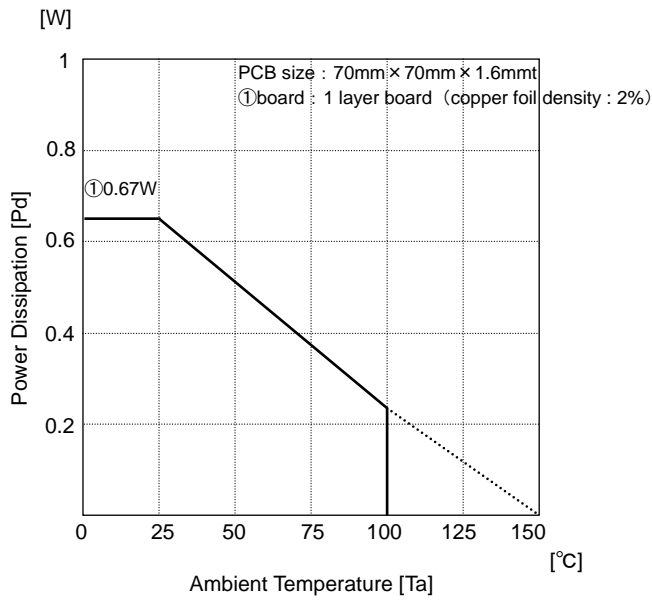

●Ordering part number

B	D
---	---

Part No.

4	1	4	0
---	---	---	---

Part No.

H	F	V
---	---	---

Package
FV : HVSO5

T	R
---	---

Packaging and forming specification
TR: Embossed tape and reel

HVSO5

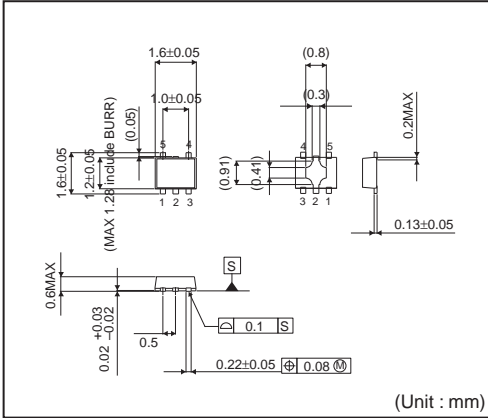

<Tape and Reel information>

Tape	Embossed carrier tape
Quantity	3000pcs
Direction of feed	TR (The direction is the 1pin of product is at the upper right when you hold reel on the left hand and you pull out the tape on the right hand)

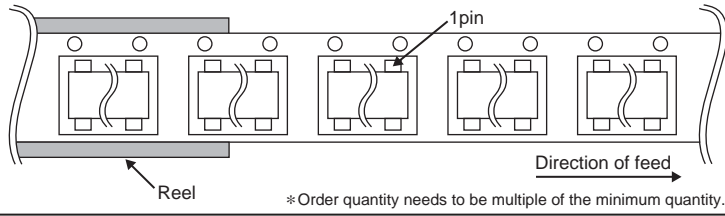

Notes

No copying or reproduction of this document, in part or in whole, is permitted without the consent of ROHM Co.,Ltd.

The content specified herein is subject to change for improvement without notice.

The content specified herein is for the purpose of introducing ROHM's products (hereinafter "Products"). If you wish to use any such Product, please be sure to refer to the specifications, which can be obtained from ROHM upon request.

Examples of application circuits, circuit constants and any other information contained herein illustrate the standard usage and operations of the Products. The peripheral conditions must be taken into account when designing circuits for mass production.

Great care was taken in ensuring the accuracy of the information specified in this document. However, should you incur any damage arising from any inaccuracy or misprint of such information, ROHM shall bear no responsibility for such damage.

The technical information specified herein is intended only to show the typical functions of and examples of application circuits for the Products. ROHM does not grant you, explicitly or implicitly, any license to use or exercise intellectual property or other rights held by ROHM and other parties. ROHM shall bear no responsibility whatsoever for any dispute arising from the use of such technical information.

The Products specified in this document are intended to be used with general-use electronic equipment or devices (such as audio visual equipment, office-automation equipment, communication devices, electronic appliances and amusement devices).

The Products specified in this document are not designed to be radiation tolerant.

While ROHM always makes efforts to enhance the quality and reliability of its Products, a Product may fail or malfunction for a variety of reasons.

Please be sure to implement in your equipment using the Products safety measures to guard against the possibility of physical injury, fire or any other damage caused in the event of the failure of any Product, such as derating, redundancy, fire control and fail-safe designs. ROHM shall bear no responsibility whatsoever for your use of any Product outside of the prescribed scope or not in accordance with the instruction manual.

The Products are not designed or manufactured to be used with any equipment, device or system which requires an extremely high level of reliability the failure or malfunction of which may result in a direct threat to human life or create a risk of human injury (such as a medical instrument, transportation equipment, aerospace machinery, nuclear-reactor controller, fuel-controller or other safety device). ROHM shall bear no responsibility in any way for use of any of the Products for the above special purposes. If a Product is intended to be used for any such special purpose, please contact a ROHM sales representative before purchasing.

If you intend to export or ship overseas any Product or technology specified herein that may be controlled under the Foreign Exchange and the Foreign Trade Law, you will be required to obtain a license or permit under the Law.



Thank you for your accessing to ROHM product informations.
More detail product informations and catalogs are available, please contact us.

ROHM Customer Support System

<http://www.rohm.com/contact/>

Компания «Life Electronics» занимается поставками электронных компонентов импортного и отечественного производства от производителей и со складов крупных дистрибьюторов Европы, Америки и Азии.

С конца 2013 года компания активно расширяет линейку поставок компонентов по направлению коаксиальный кабель, кварцевые генераторы и конденсаторы (керамические, пленочные, электролитические), за счёт заключения дистрибьюторских договоров

Мы предлагаем:

- Конкурентоспособные цены и скидки постоянным клиентам.
- Специальные условия для постоянных клиентов.
- Подбор аналогов.
- Поставку компонентов в любых объемах, удовлетворяющих вашим потребностям.
- Приемлемые сроки поставки, возможна ускоренная поставка.
- Доставку товара в любую точку России и стран СНГ.
- Комплексную поставку.
- Работу по проектам и поставку образцов.
- Формирование склада под заказчика.
- Сертификаты соответствия на поставляемую продукцию (по желанию клиента).
- Тестирование поставляемой продукции.
- Поставку компонентов, требующих военную и космическую приемку.
- Входной контроль качества.
- Наличие сертификата ISO.

В составе нашей компании организован Конструкторский отдел, призванный помогать разработчикам, и инженерам.

Конструкторский отдел помогает осуществить:

- Регистрацию проекта у производителя компонентов.
- Техническую поддержку проекта.
- Защиту от снятия компонента с производства.
- Оценку стоимости проекта по компонентам.
- Изготовление тестовой платы монтаж и пусконаладочные работы.



Тел: +7 (812) 336 43 04 (многоканальный)
Email: org@lifeelectronics.ru