

THIS DRAWING IS UNPUBLISHED. RELEASED FOR PUBLICATION 20
 © COPYRIGHT 20 BY - ALL RIGHTS RESERVED.

LOC		DIST		REVISIONS			
P	LTR	DESCRIPTION		DATE	DWN	APVD	
D		REVISED PER ECR-17-002389		20FEB2017	S.W	W.H	

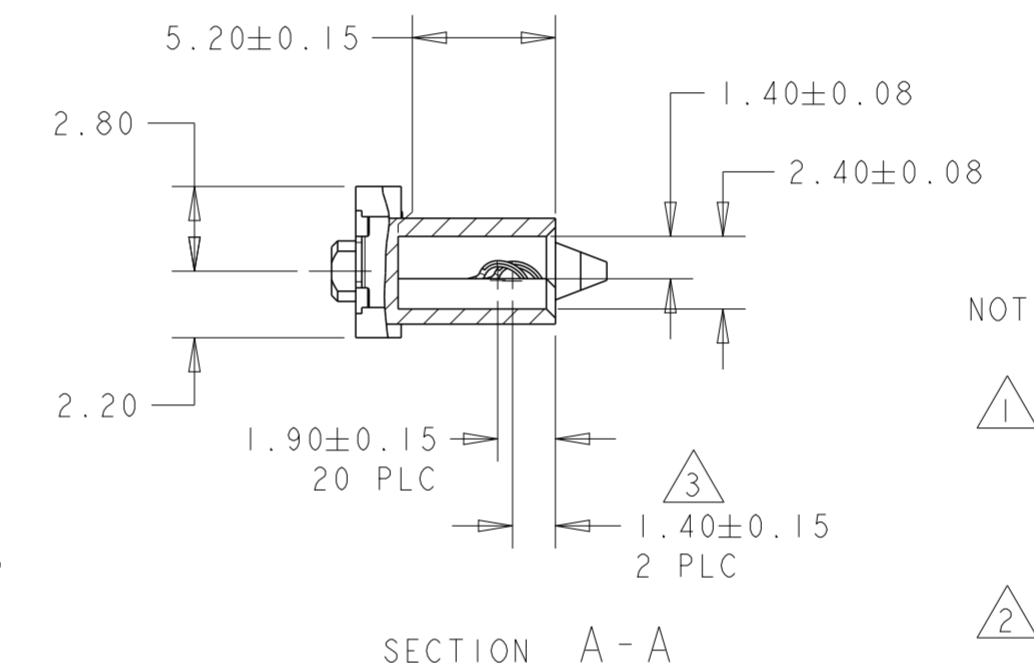

- NOTES:
- 1 MATERIAL:
HOUSING: HIGH TEMP THERMOPLASTIC, UL94V-0,
COLOR: BLACK
CONTACT: COPPER ALLOY
BOARDLOCK: COPPER ALLOY
 - 2 FINISH:
CONTACT AREA: SEE TABLE GOLD PLATING
SOLDERTAIL: MIN 2.54um MATTE TIN PLATING
UNDERPLATE: MIN 1.27um NICKEL PLATING
 - 3 PIN #P4 AND #PI2 ONLY
 - 4 VIEWS IN SHEET 1 ARE SHOWN WITHOUT PICKUP CAP
 - 5 HOUSING OPENING APPLICABLE TO -2 AND -5 ONLY

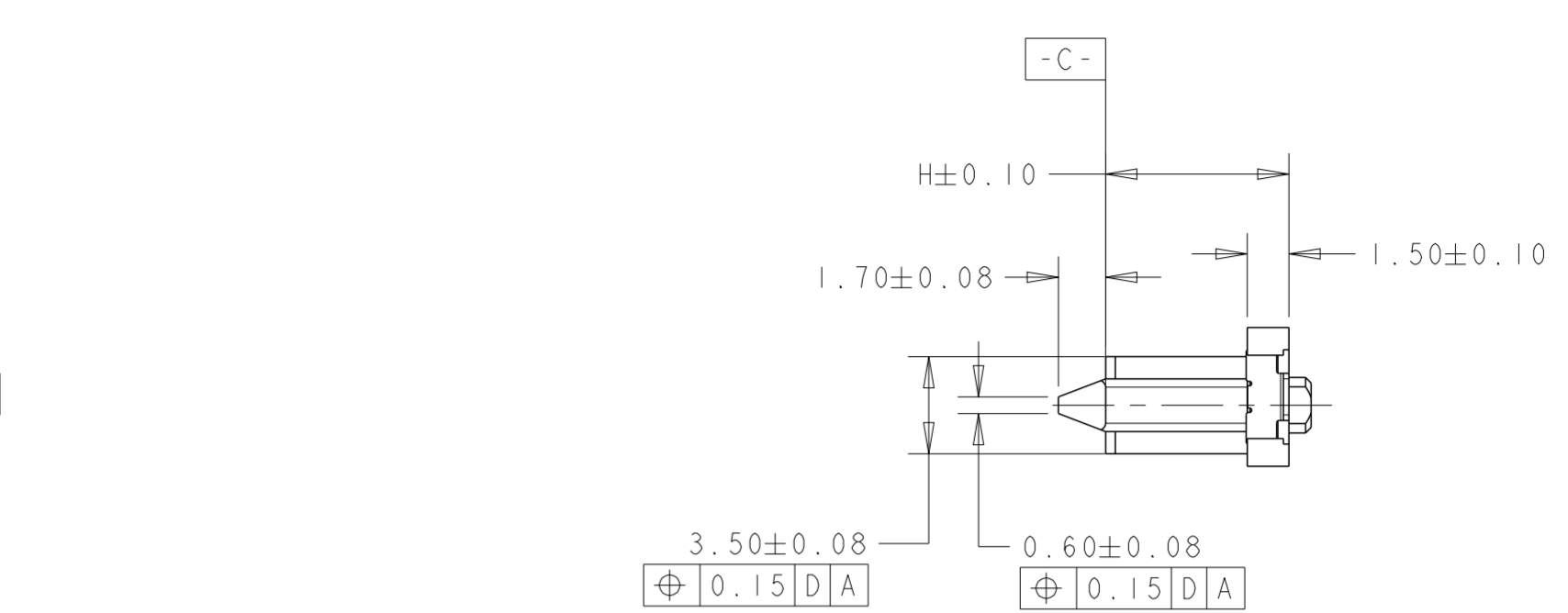
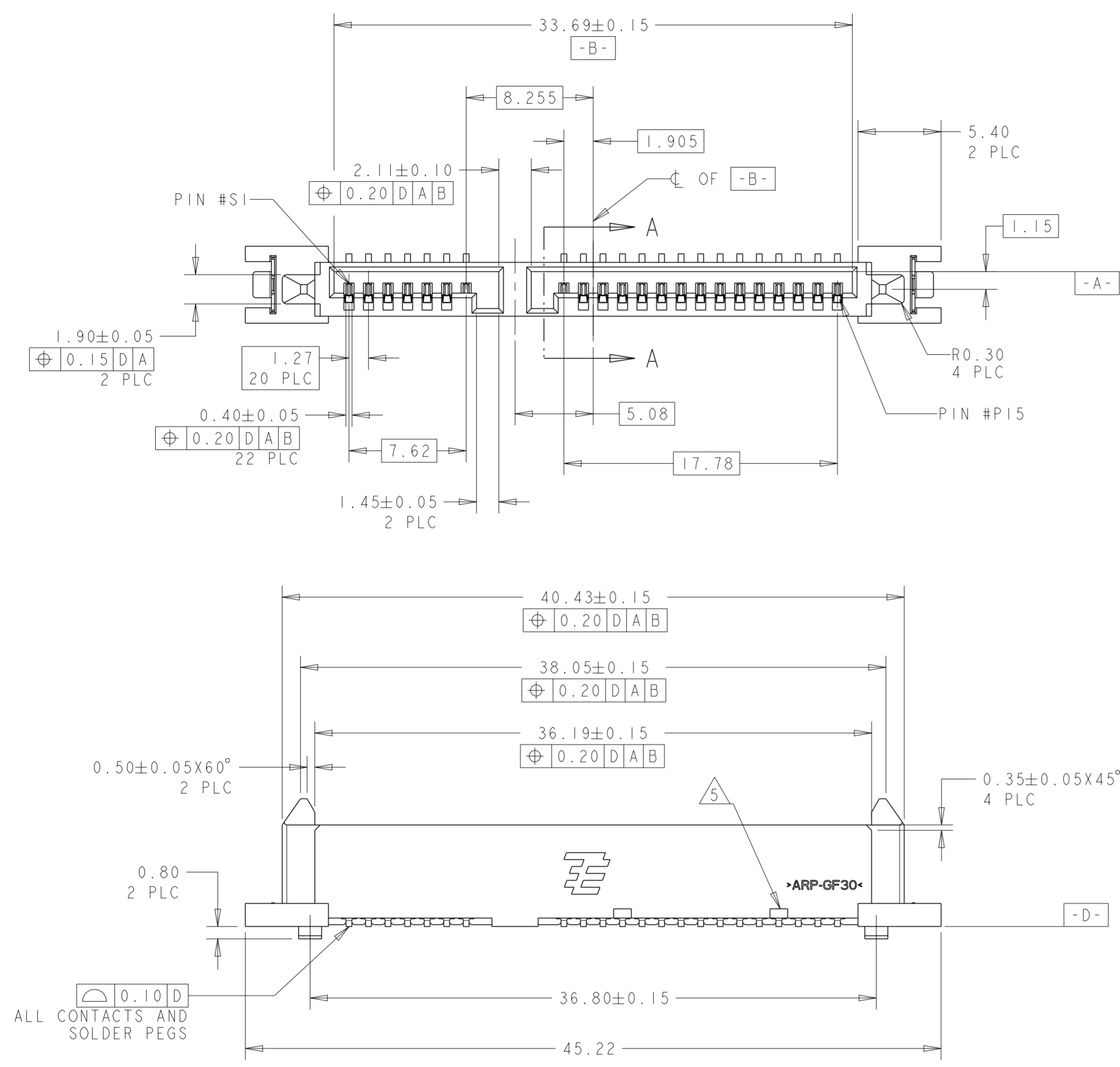
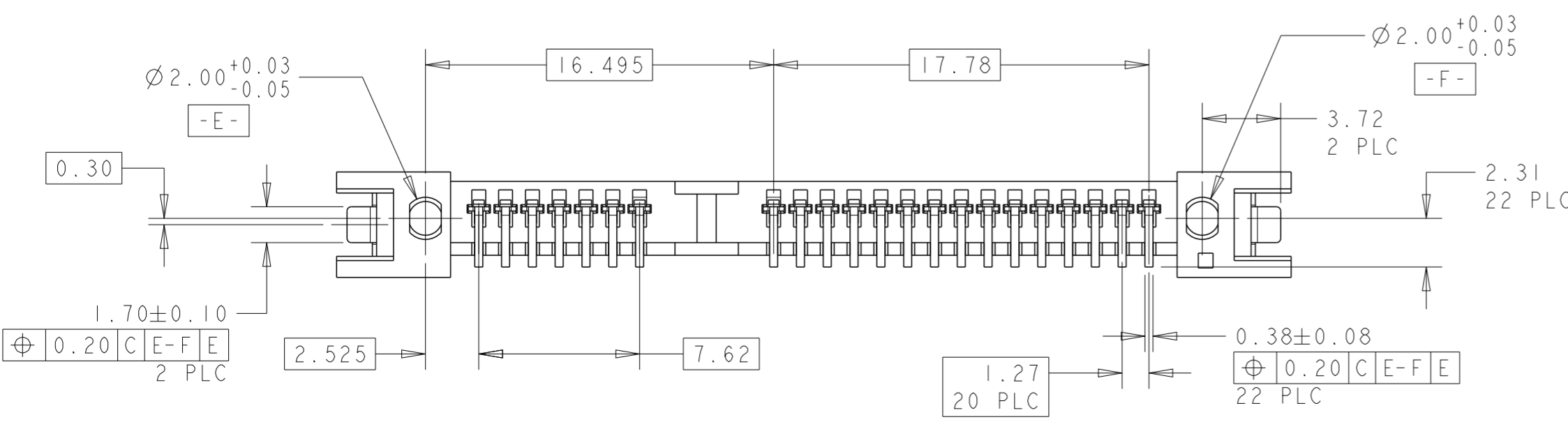

0.76	450	T&R	YES	STANDARD PROFILE	8.15	1735284-7
0.38	550	T&R	YES	LOW PROFILE	6.60	1735284-6
Au um	QTY/REEL	PACKAGE	PICK-UP CAP	REMARKS	HEIGHT (H)	PART NUMBER

0.76	48	TYPE 1	YES	STANDARD PROFILE	8.15	1735284-5
0.38	20	TYPE 2	YES	LOW PROFILE	6.60	1735284-4
0.38	20	TYPE 2	NO	LOW PROFILE	6.60	1735284-3
0.76	20	TYPE 2	NO	STANDARD PROFILE	8.15	1735284-2
0.38	48	TYPE 1	YES	LOW PROFILE	6.60	1735284-1
Au um	QTY/TRAY	TRAY	PICK-UP CAP	REMARKS	HEIGHT (H)	PART NUMBER

THIS DRAWING IS A CONTROLLED DOCUMENT.

DWN SK LEAW 14NOV2005	TE Connectivity NAME: SATA BACKPLANE RECEPTACLE, VERTICAL, SMT SIZE: A2 CAGE CODE: 00779 DRAWING NO: 1735284 RESTRICTED TO:
CHK SF LEONG 14NOV2005	
APVD SF LEONG 14NOV2005	
PRODUCT SPEC: 108-51052-1	
MATERIAL: 1	WEIGHT: - SCALE: 4:1 SHEET 1 OF 5 REV D

CUSTOMER DRAWING

THIS DRAWING IS UNPUBLISHED. RELEASED FOR PUBLICATION 20
 © COPYRIGHT 20 BY - ALL RIGHTS RESERVED.

LOC	DIST	REVISIONS				
P	LTR	DESCRIPTION	DATE	DWN	APVD	
DY		SEE SHEET 1	-	-	-	

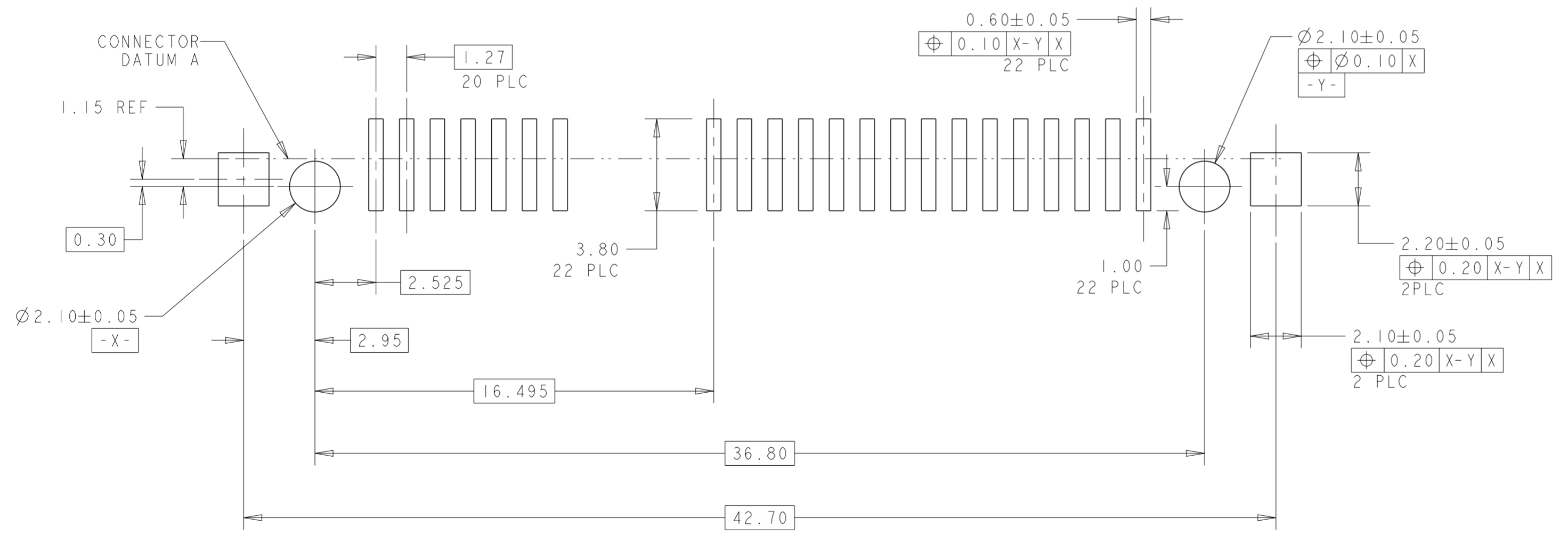
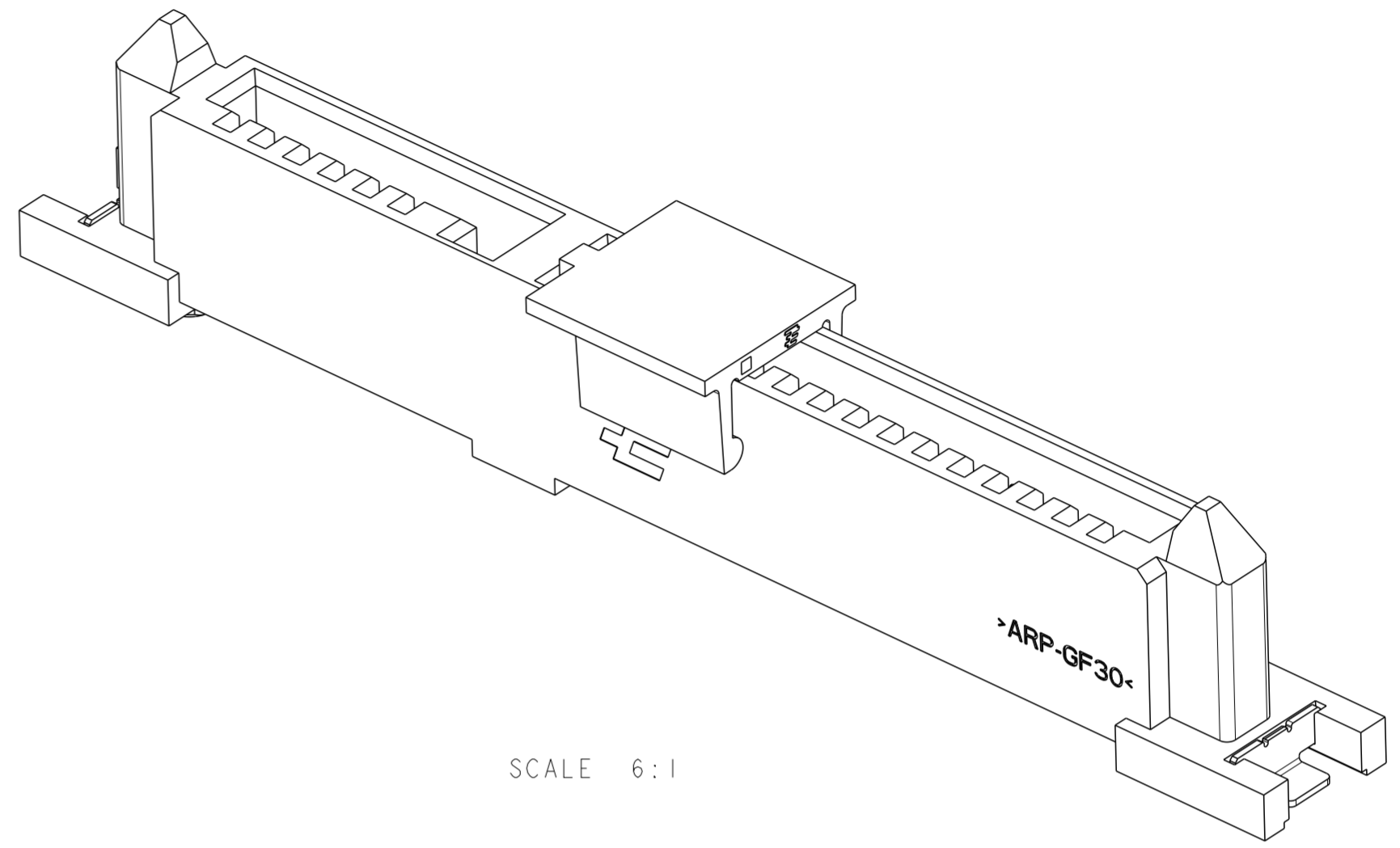
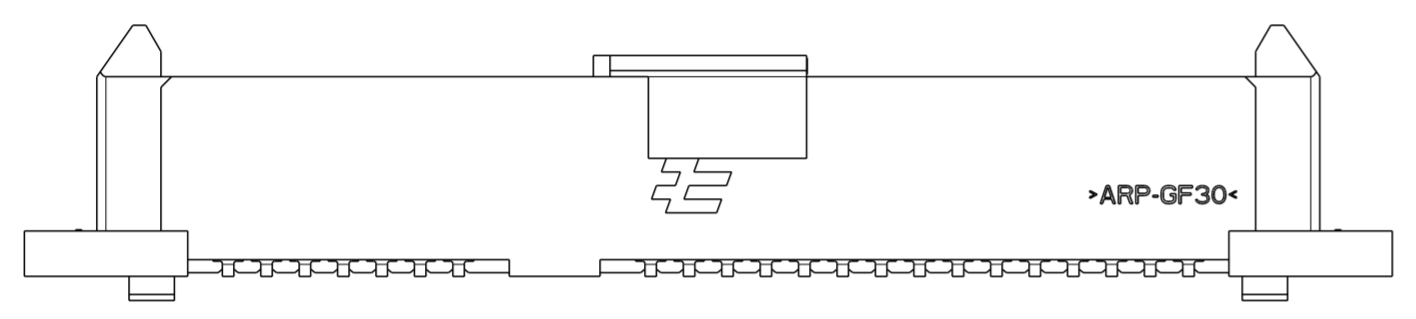
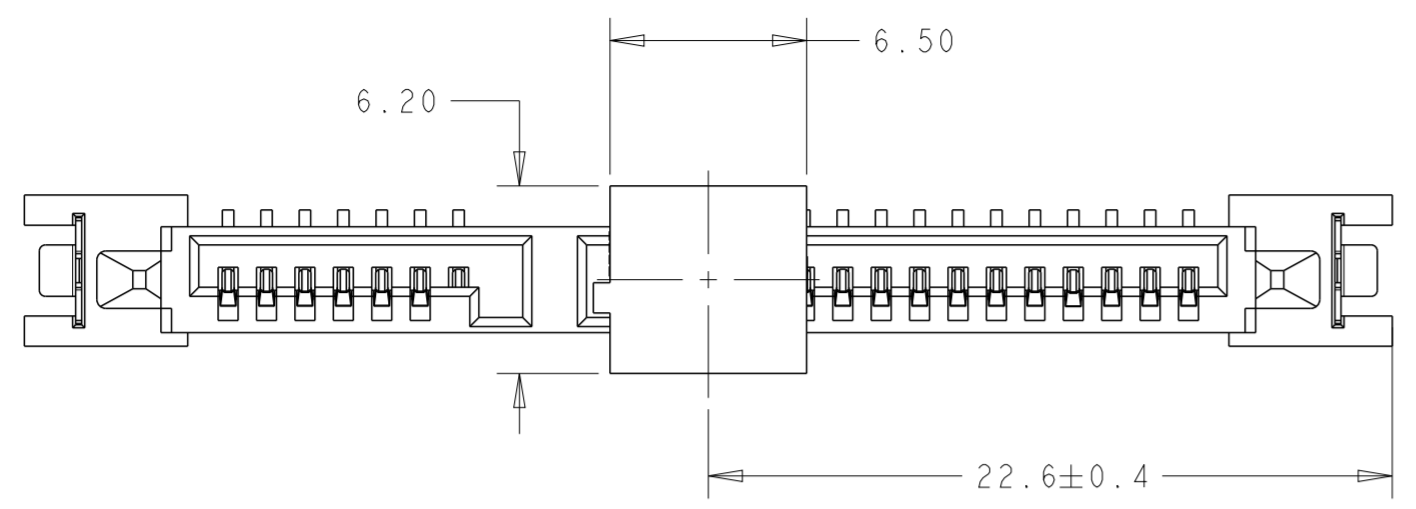

RECOMMENDED PCB LAYOUT
 SCALE 6:1

THIS DRAWING IS A CONTROLLED DOCUMENT.		DWN	TE Connectivity		
DIMENSIONS: mm		CHK			
TOLERANCES UNLESS OTHERWISE SPECIFIED:		APVD	NAME		
0 PLC ±	1 PLC ±	PRODUCT SPEC	SATA BACKPLANE RECEPTACLE, VERTICAL, SMT		
2 PLC ±0.20	3 PLC ±	APPLICATION SPEC	SIZE	CAGE CODE	DRAWING NO
4 PLC ±	ANGLES ±3°	WEIGHT	A200779	G-1735284	RESTRICTED TO
MATERIAL	FINISH	CUSTOMER DRAWING	SCALE 4:1	SHEET 2 OF 5	REV D

THIS DRAWING IS UNPUBLISHED. RELEASED FOR PUBLICATION 20
 © COPYRIGHT 20 BY - ALL RIGHTS RESERVED.

LOC DIST
 DY

REVISIONS				
P	LTR	DESCRIPTION	DATE	APVD
-		SEE SHEET 1	-	-

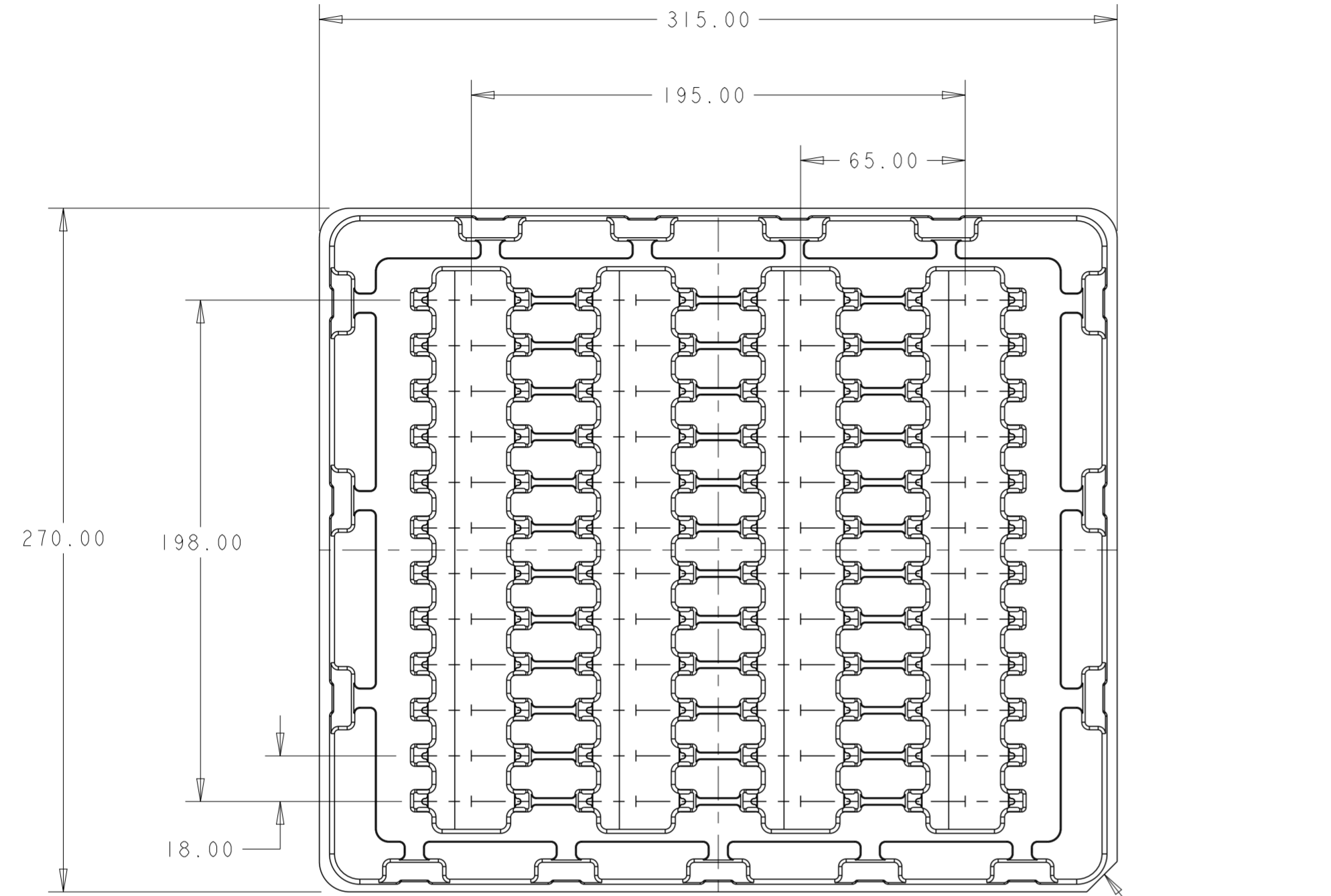

CUT CORNER

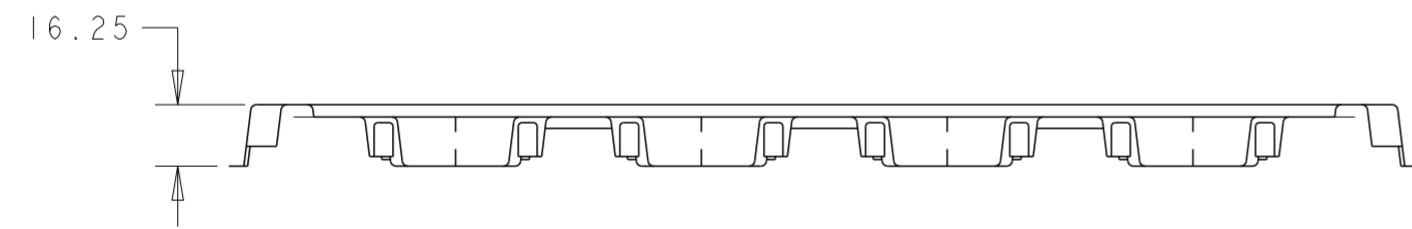

TRAY, TYPE 1
 QTY/TRAY: 48PCS

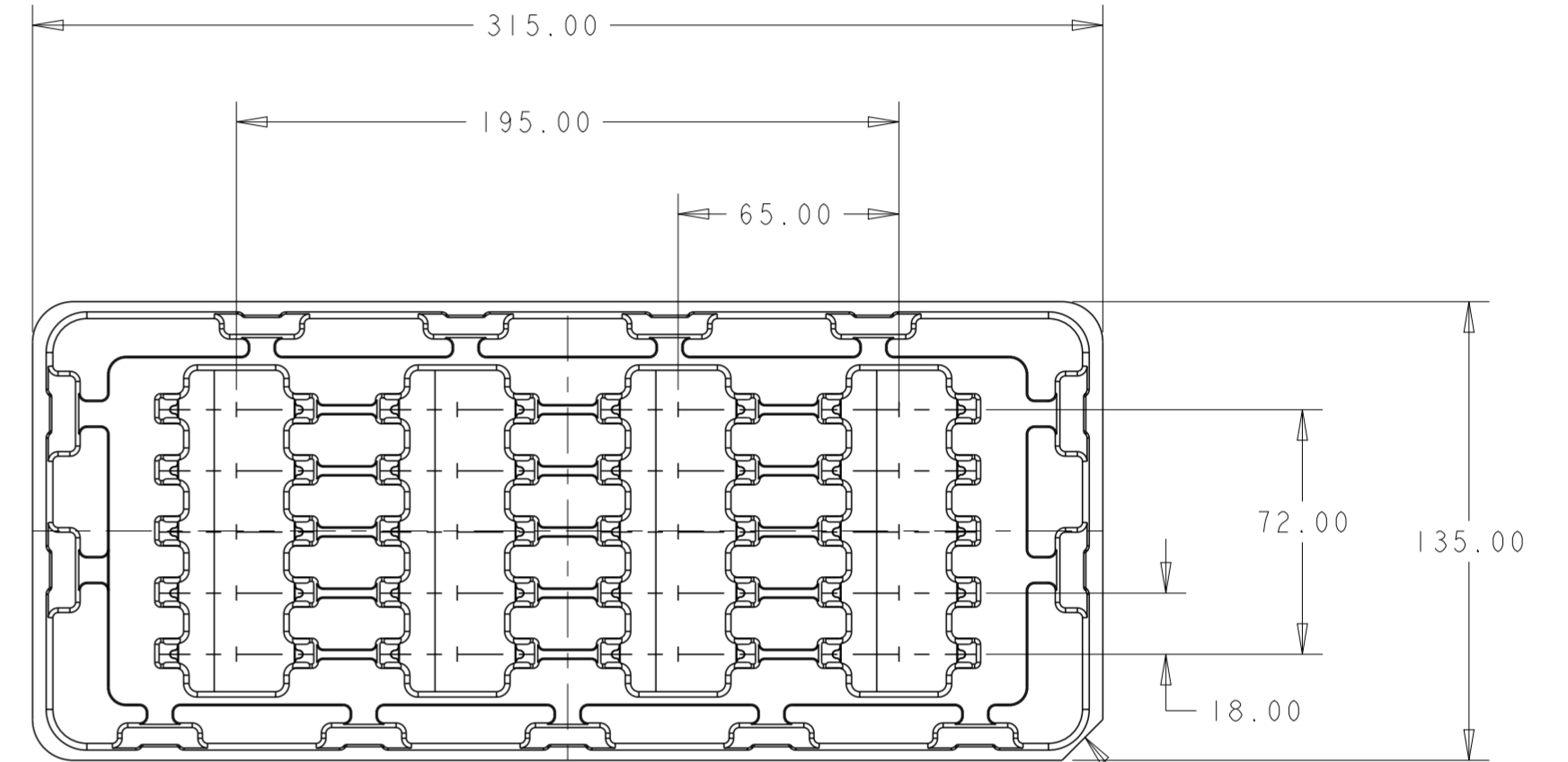

CUT CORNER

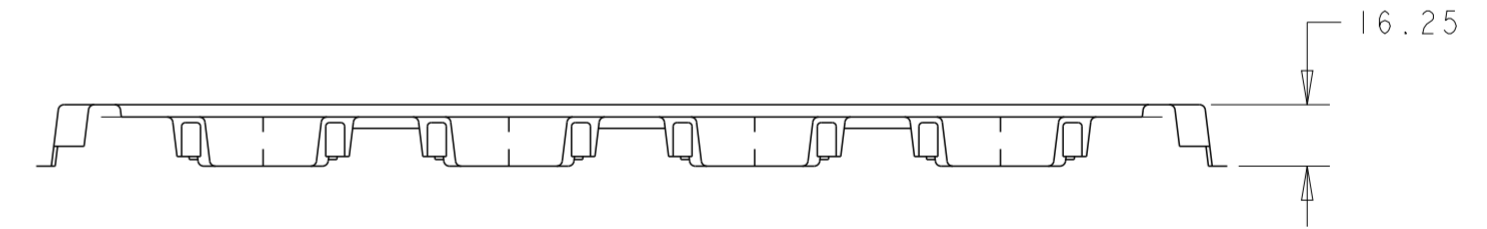

TRAY, TYPE 2
 QTY/TRAY: 20PCS

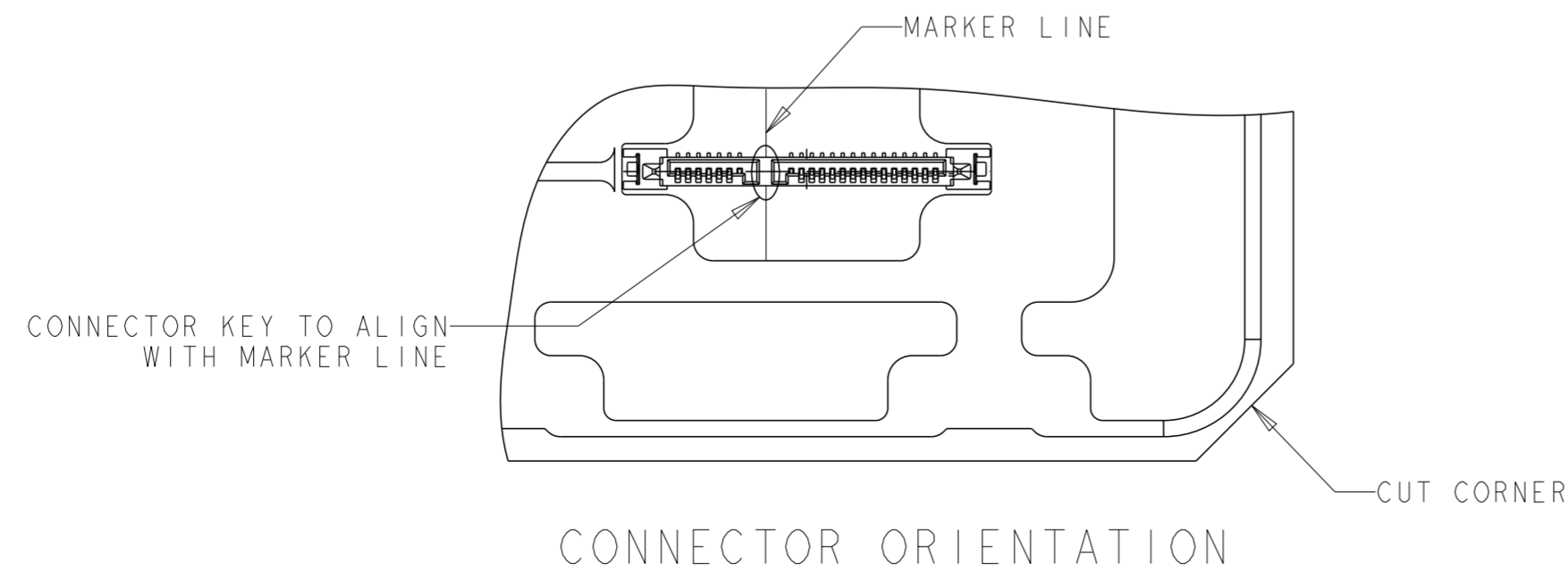

CONNECTOR ORIENTATION

THIS DRAWING IS A CONTROLLED DOCUMENT.		DWN	STE TE Connectivity	
DIMENSIONS: mm		CHK		
TOLERANCES UNLESS OTHERWISE SPECIFIED:		APVD	NAME	
0 PLC	±	PRODUCT SPEC	SATA BACKPLANE RECEPTACLE, VERTICAL, SMT	
1 PLC	±	APPLICATION SPEC	SIZE	CAGE CODE
2 PLC	±0.20	WEIGHT	A2	00779
3 PLC	±	CUSTOMER DRAWING	DRAWING NO	G-1735284
4 PLC	±		SCALE	4:1
ANGLES	±3°		SHEET	3 OF 5
FINISH			REV	D

THIS DRAWING IS UNPUBLISHED. RELEASED FOR PUBLICATION 20
 © COPYRIGHT 20 BY - ALL RIGHTS RESERVED.

LOC		DIST		REVISIONS			
P	LTR	DESCRIPTION	DATE	DWN	APVD		
		SEE SHEET 1					

T&R FOR LOW PROFILE

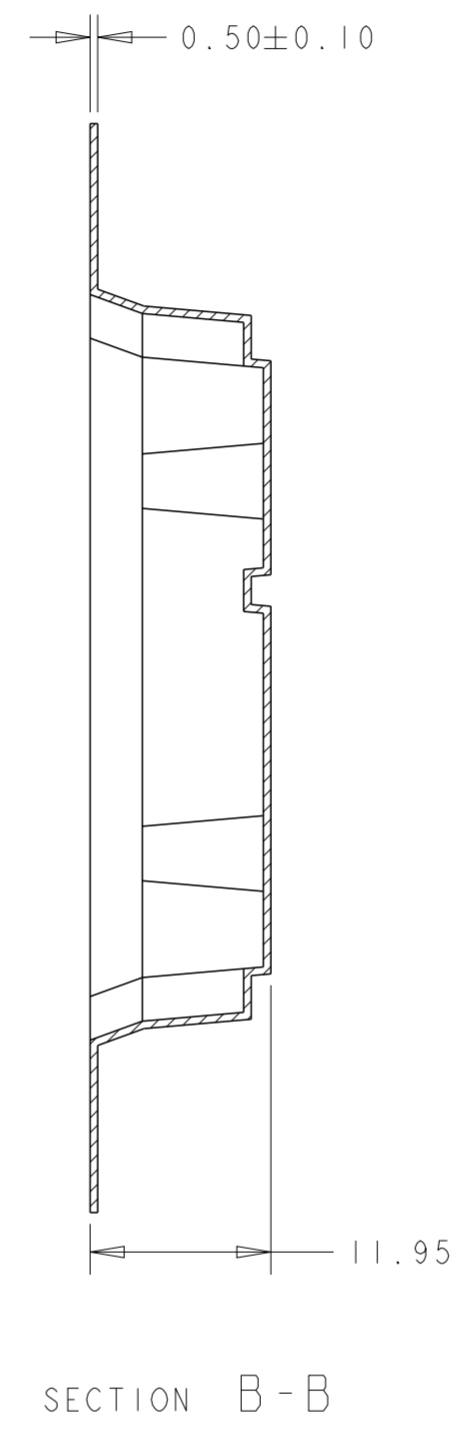
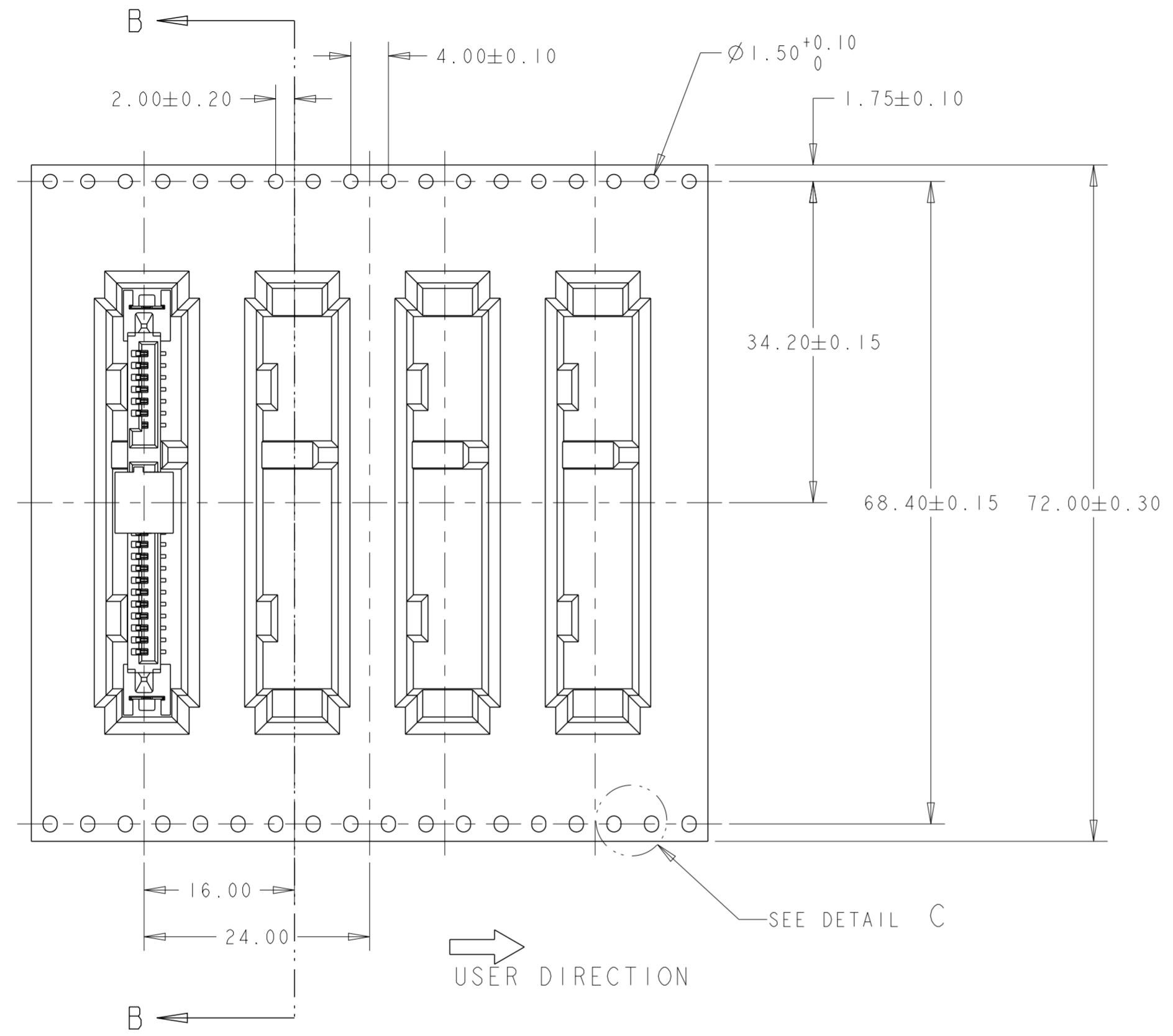

- NOTES:
1. PACKAGING QUANTITY: 550 PCS PER REEL.
 2. REEL: $\varnothing 380-\varnothing 100$ HUB-89W(72.4W INSIDE).

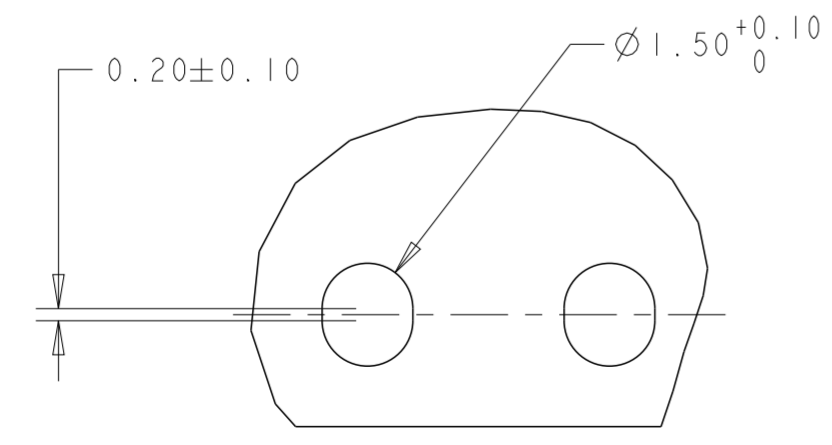

DETAIL C
SCALE 8:1

THIS DRAWING IS A CONTROLLED DOCUMENT.		DWN	STE TE Connectivity		
DIMENSIONS: mm		CHK			
TOLERANCES UNLESS OTHERWISE SPECIFIED:		APVD	NAME SATA BACKPLANE RECEPTACLE, VERTICAL, SMT		
0 PLC ±		PRODUCT SPEC	SIZE	CAGE CODE	DRAWING NO
1 PLC ±		APPLICATION SPEC	A2	G-1735284	RESTRICTED TO
2 PLC ±0.3		WEIGHT	SCALE 2:1 SHEET 4 OF 5 REV D		
3 PLC ±		CUSTOMER DRAWING			
4 PLC ±					
ANGLES ±5°					
FINISH					

THIS DRAWING IS UNPUBLISHED. RELEASED FOR PUBLICATION 20
 © COPYRIGHT 20 BY - ALL RIGHTS RESERVED.

LOC		DIST		REVISIONS			
P	LTR	DESCRIPTION		DATE	DWN	APVD	
		SEE SHEET 1					

T&R FOR STANDARD PROFILE

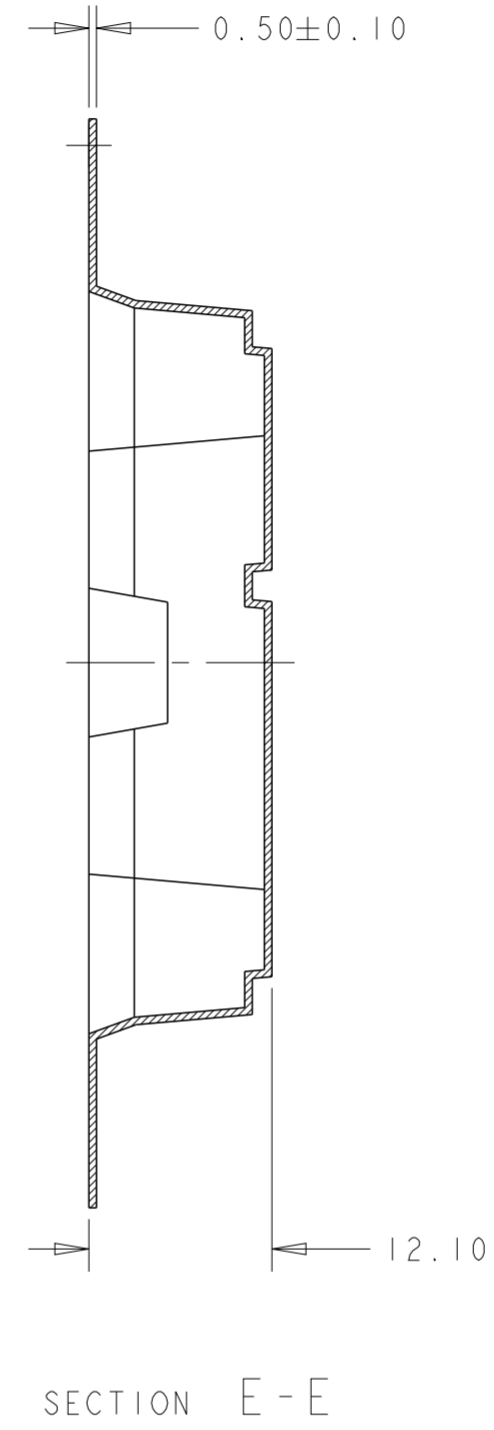
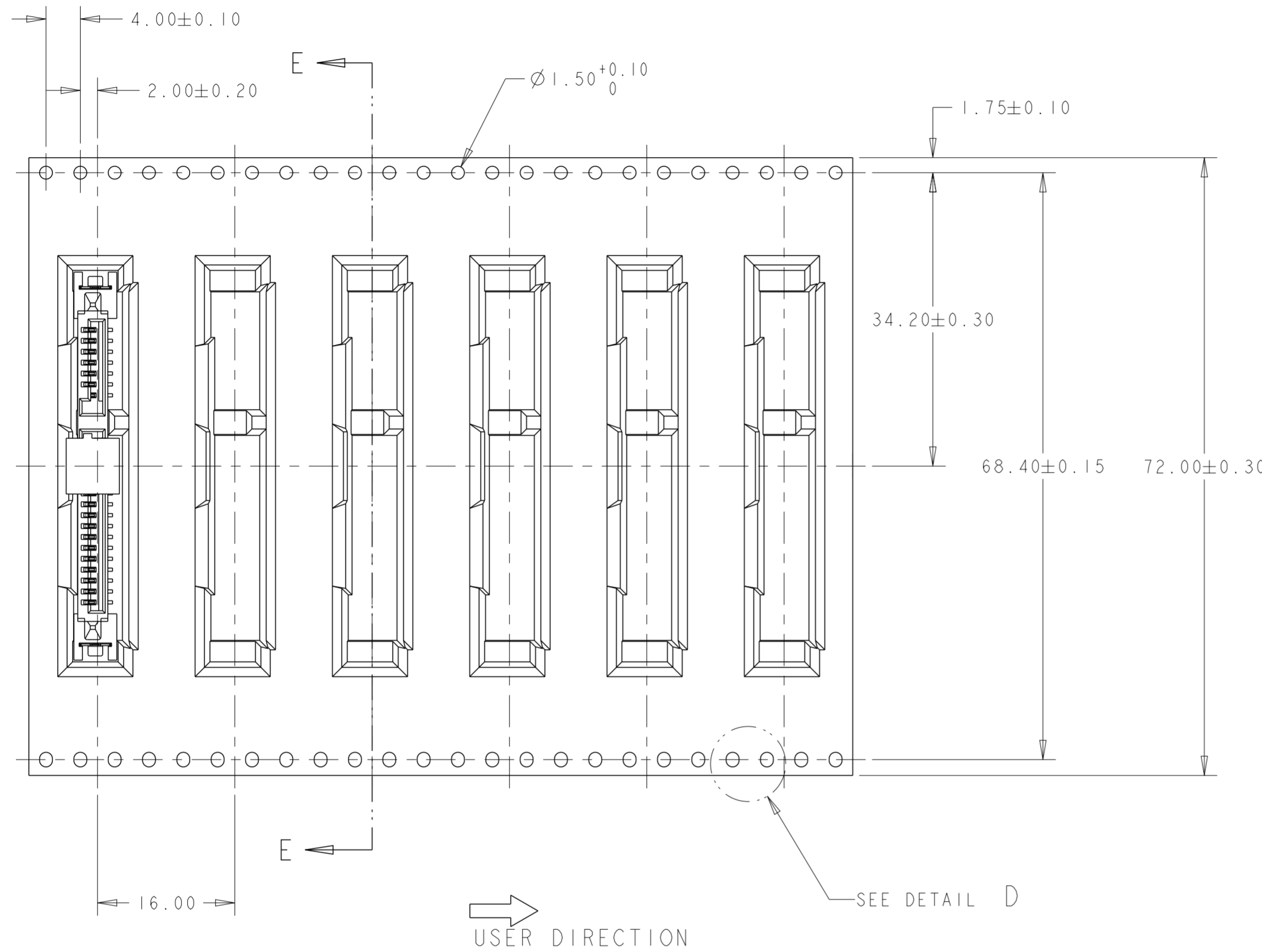

- NOTES:
 1. PACKAGING QUANTITY: 450 PCS PER REEL.
 2. REEL: Ø380-Ø100HUB-89W(72.4W INSIDE).

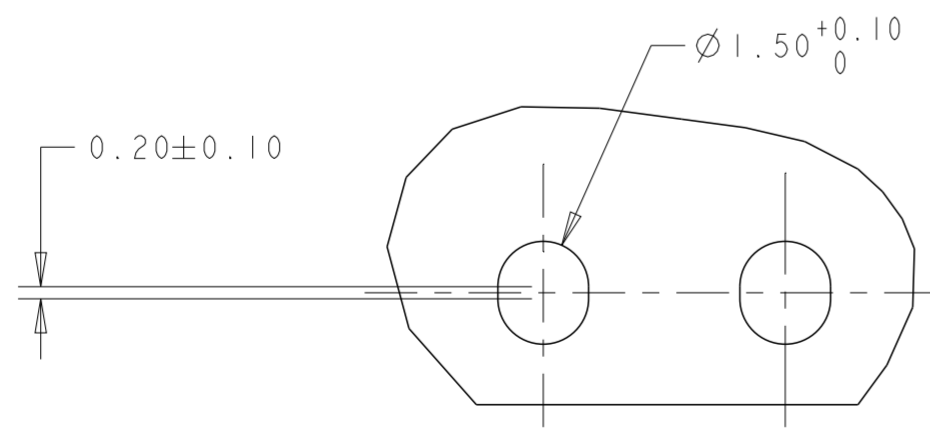

DETAIL D
 SCALE 8:1

THIS DRAWING IS A CONTROLLED DOCUMENT.		DWN	STE TE Connectivity		
DIMENSIONS: mm		CHK			
TOLERANCES UNLESS OTHERWISE SPECIFIED:		APVD	NAME SATA BACKPLANE RECEPTACLE, VERTICAL, SMT		
0 PLC ±		PRODUCT SPEC	SIZE A2		
1 PLC ±		APPLICATION SPEC	CAGE CODE C-1735284		
2 PLC ±0.3		WEIGHT	DRAWING NO C-1735284		
3 PLC ±		CUSTOMER DRAWING	RESTRICTED TO		
4 PLC ±			SCALE 2:1 SHEET 5 OF 5 REV D		
ANGLES ±5°					
FINISH					

Компания «Life Electronics» занимается поставками электронных компонентов импортного и отечественного производства от производителей и со складов крупных дистрибьюторов Европы, Америки и Азии.

С конца 2013 года компания активно расширяет линейку поставок компонентов по направлению коаксиальный кабель, кварцевые генераторы и конденсаторы (керамические, пленочные, электролитические), за счёт заключения дистрибьюторских договоров

Мы предлагаем:

- Конкурентоспособные цены и скидки постоянным клиентам.
- Специальные условия для постоянных клиентов.
- Подбор аналогов.
- Поставку компонентов в любых объемах, удовлетворяющих вашим потребностям.
- Приемлемые сроки поставки, возможна ускоренная поставка.
- Доставку товара в любую точку России и стран СНГ.
- Комплексную поставку.
- Работу по проектам и поставку образцов.
- Формирование склада под заказчика.
- Сертификаты соответствия на поставляемую продукцию (по желанию клиента).
- Тестирование поставляемой продукции.
- Поставку компонентов, требующих военную и космическую приемку.
- Входной контроль качества.
- Наличие сертификата ISO.

В составе нашей компании организован Конструкторский отдел, призванный помогать разработчикам, и инженерам.

Конструкторский отдел помогает осуществить:

- Регистрацию проекта у производителя компонентов.
- Техническую поддержку проекта.
- Защиту от снятия компонента с производства.
- Оценку стоимости проекта по компонентам.
- Изготовление тестовой платы монтаж и пусконаладочные работы.



Тел: +7 (812) 336 43 04 (многоканальный)

Email: org@lifeelectronics.ru