

## Description

The SAMB11 is an ultra-low power Bluetooth® SMART (BLE 4.1) System on a Chip with Integrated MCU, Transceiver, Modem, MAC, PA, TR Switch, and Power Management Unit (PMU). It is a standalone Cortex®-M0 applications processor with embedded Flash memory and BLE connectivity.

The qualified Bluetooth Smart protocol stack is stored in dedicated ROM, the firmware includes L2CAP service layer protocols, Security Manager, Attribute protocol (ATT), Generic Attribute Profile (GATT) and the Generic Access Profile (GAP). Additionally, application profiles such as Proximity, Thermometer, Heart Rate, Blood Pressure, and many others are supported and included in the protocol stack.

## Features

- 2.4GHz transceiver and Modem
  - -95dBm/-93dBm programmable receiver sensitivity
  - -20 to +3.5dBm programmable TX output power
  - Integrated T/R switch
  - Single wire antenna connection
- ARM® Cortex®-M0 32-bit processor
  - Single wire Debug (SWD) interface
  - 4-channel DMA controller
  - Brown-out detector and Power On Reset
  - Watchdog Timer
- Memory
  - 128kB embedded RAM (96kB available for application)
  - 128kB embedded ROM
  - 256kB Stacked Flash Memory
- Hardware Security Accelerators
  - AES-128
  - SHA-256
- Peripherals
  - 23 digital and 4 mixed-signal GPIOs with 96kΩ internal programmable pull-up or down resistors and retention capability, and 3 wake up GPIOs with 96kΩ internal pull-up resistor
  - 2x SPI Master/Slave
  - 2x I<sup>2</sup>C Master/Slave and 1x I<sup>2</sup>C Slave
  - 2x UART
  - Three-axis quadrature decoder
  - 4x Pulse Width Modulation (PWM), three General Purpose Timers, and one Wakeup Timer
  - 4-channel 11-bit ADC
- Clock
  - Integrated 26MHz RC oscillator

- 26MHz crystal oscillator
  - Integrated 2MHz sleep RC oscillator
  - 32.768kHz RTC crystal oscillator
- Ultra Low Power
  - 1.1µA sleep current (8K RAM retention and RTC running)
  - 3.0mA peak TX current (0dBm, 3.6V)
  - 4.2mA peak RX current (3.6V, -93dBm sensitivity)
- Integrated Power Management
  - 2.3 to 4.3V battery voltage range
  - 2.3 to 3.6V input range for I/O (limited by Flash memory)
  - Fully integrated Buck DC/DC converter
- Bluetooth SIG Certification
  - The ATSAMB11 uses the ATBTLC1000 as its Bluetooth controller and is certified under the ATBTLC1000.
    - QD ID Controller (see declaration [D028678](#))
    - QD ID Host (see declaration [D028679](#))

## Table of Contents

---

<b>1</b>	<b>Ordering Information</b> .....	<b>5</b>
<b>2</b>	<b>Package Information</b> .....	<b>5</b>
<b>3</b>	<b>Block Diagram</b> .....	<b>6</b>
<b>4</b>	<b>Pinout Information</b> .....	<b>7</b>
<b>5</b>	<b>Package drawing</b> .....	<b>10</b>
<b>6</b>	<b>Power Management</b> .....	<b>11</b>
6.1	Power Architecture .....	11
6.2	DC/DC Converter.....	12
6.3	Power Consumption.....	13
6.3.1	Description of Device States .....	13
6.3.2	Controlling the Device States.....	14
6.3.3	Current Consumption in Various Device States .....	14
6.4	Power-up Sequence .....	15
6.5	Power On Reset (POR) and Brown Out Detector (BOD) .....	16
6.6	Digital and Mixed-Signal I/O Pin Behavior during Power-Up Sequences.....	17
<b>7</b>	<b>Clocking</b> .....	<b>19</b>
7.1	Overview.....	19
7.2	26MHz Crystal Oscillator (XO).....	20
7.3	32.768kHz RTC Crystal Oscillator (RTC XO) .....	21
7.3.1	General Information .....	21
7.3.2	RTC XO Design and Interface Specification .....	23
7.3.3	RTC Characterization with Gm Code Variation at Supply 1.2V and Temp. = 25°C .....	23
7.3.4	RTC Characterization with Supply Variation and Temp. = 25°C .....	24
7.4	2MHz and 26MHz Integrated RC Oscillator .....	25
<b>8</b>	<b>CPU and Memory Subsystem</b> .....	<b>27</b>
8.1	ARM Subsystem .....	27
8.1.2	Features.....	27
8.1.3	Module Descriptions .....	28
8.2	Memory Subsystem .....	29
8.2.1	Shared Instruction and Data Memory .....	29
8.2.2	ROM .....	30
8.2.3	BLE Retention Memory.....	30
8.3	Non-volatile Memory .....	30
8.4	Flash Memory .....	30
<b>9</b>	<b>Bluetooth Low Energy (BLE) Subsystem</b> .....	<b>31</b>
9.1	BLE Core .....	31
9.1.1	Features.....	31
9.2	BLE Radio.....	31
9.2.1	Receiver Performance .....	31
9.2.2	Transmitter Performance .....	32
9.3	Atmel Bluetooth SmartConnect Stack.....	33
<b>10</b>	<b>External Interfaces</b> .....	<b>34</b>

10.1	Overview.....	34
10.2	I <sup>2</sup> C Master/Slave Interface.....	36
10.2.1	Description.....	36
10.2.2	I <sup>2</sup> C Interface Timing.....	37
10.3	SPI Master/Slave Interface.....	38
10.3.1	Description.....	38
10.3.2	SPI Interface Modes.....	39
10.3.3	SPI Slave Timing.....	40
10.3.4	SPI Master Timing.....	41
10.4	UART Interface.....	42
10.5	GPIOs.....	42
10.6	Analog to Digital Converter (ADC).....	44
10.6.1	Overview.....	44
10.6.2	Timing.....	44
10.6.3	Performance.....	45
10.7	Software Programmable Timer and Pulse Width Modulator.....	48
10.8	Clock Output.....	48
10.8.1	Variable Frequency Clock Output Using Fractional Divider.....	48
10.8.2	Fixed Frequency Clock Output.....	48
10.9	Three-axis Quadrature Decoder.....	49
<b>11</b>	<b>Reference Design.....</b>	<b>50</b>
<b>12</b>	<b>Bill of Material (BOM).....</b>	<b>51</b>
<b>13</b>	<b>Electrical Characteristics.....</b>	<b>52</b>
13.1	Absolute Maximum Ratings.....	52
13.2	Recommended Operating Conditions.....	52
13.3	DC Characteristics.....	53
<b>14</b>	<b>Reflow Profile Information.....</b>	<b>54</b>
14.1	Storage Condition.....	54
14.1.1	Moisture Barrier Bag Before Opened.....	54
14.1.2	Moisture Barrier Bag Open.....	54
14.2	Stencil Design.....	54
14.3	Baking Conditions.....	54
14.4	Soldering and Reflow Condition.....	54
14.4.1	Reflow Oven.....	54
<b>15</b>	<b>Errata.....</b>	<b>56</b>
<b>16</b>	<b>Reference Documentation and Support.....</b>	<b>57</b>
16.1	Reference Documents.....	57
<b>17</b>	<b>Document Revision History.....</b>	<b>58</b>

## 1 Ordering Information

Ordering Code	Package	Description
ATSAMB11G18A-MU-T	6x6mm QFN 48	SAMB11Tape & Reel
ATSAMB11G18A-MU-Y	6x6mm QFN 48	SAMB11 Tray

## 2 Package Information

Table 2-1. SAMB11 6x6 QFN 48 Package Information

Parameter	Value	Units	Tolerance
Package Size	6x6	mm	±0.1 mm
QFN Pad Count	48		
Total Thickness	0.85	mm	+0.15/-0.05mm
QFN Pad Pitch	0.4		
Pad Width	0.2		
Exposed Pad size	4.2x4.2		

### 3 Block Diagram

Figure 3-1. SAMB11 Block Diagram

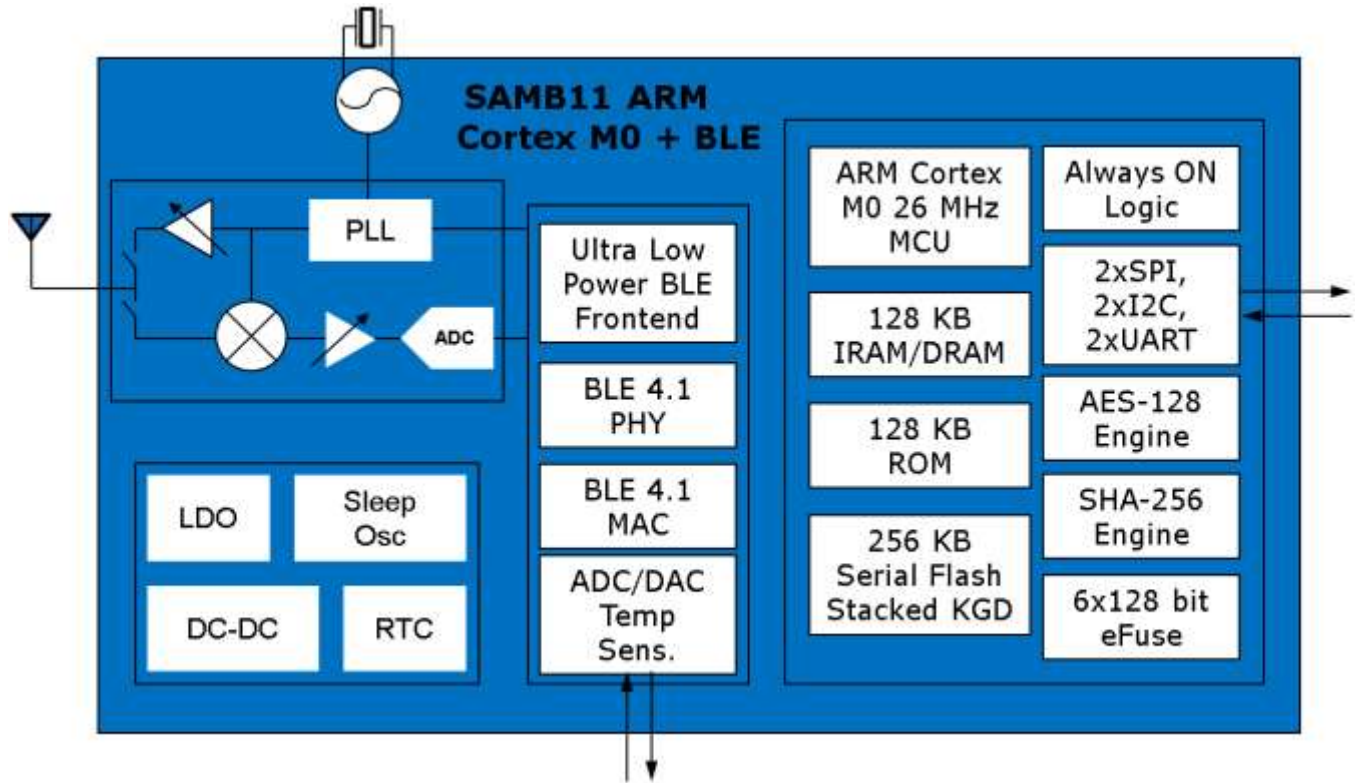

## 4 Pinout Information

SAMB11 is offered in an exposed pad 48-pin QFN package. This package has an exposed paddle that must be connected to the system board ground. The QFN package pin assignment is shown in Figure 4-1. The color shading is used to indicate the pin type as follows:

- Red – analog
- Green – digital I/O (switchable power domain)
- Blue – digital I/O (always-on power domain)
- Yellow – digital I/O power
- Purple – PMU
- Shaded green/red – configurable mixed-signal GPIO (digital/analog)

The SAMB11 pins are described in Table 4-1.

Figure 4-1. SAMB11 Pin Assignment

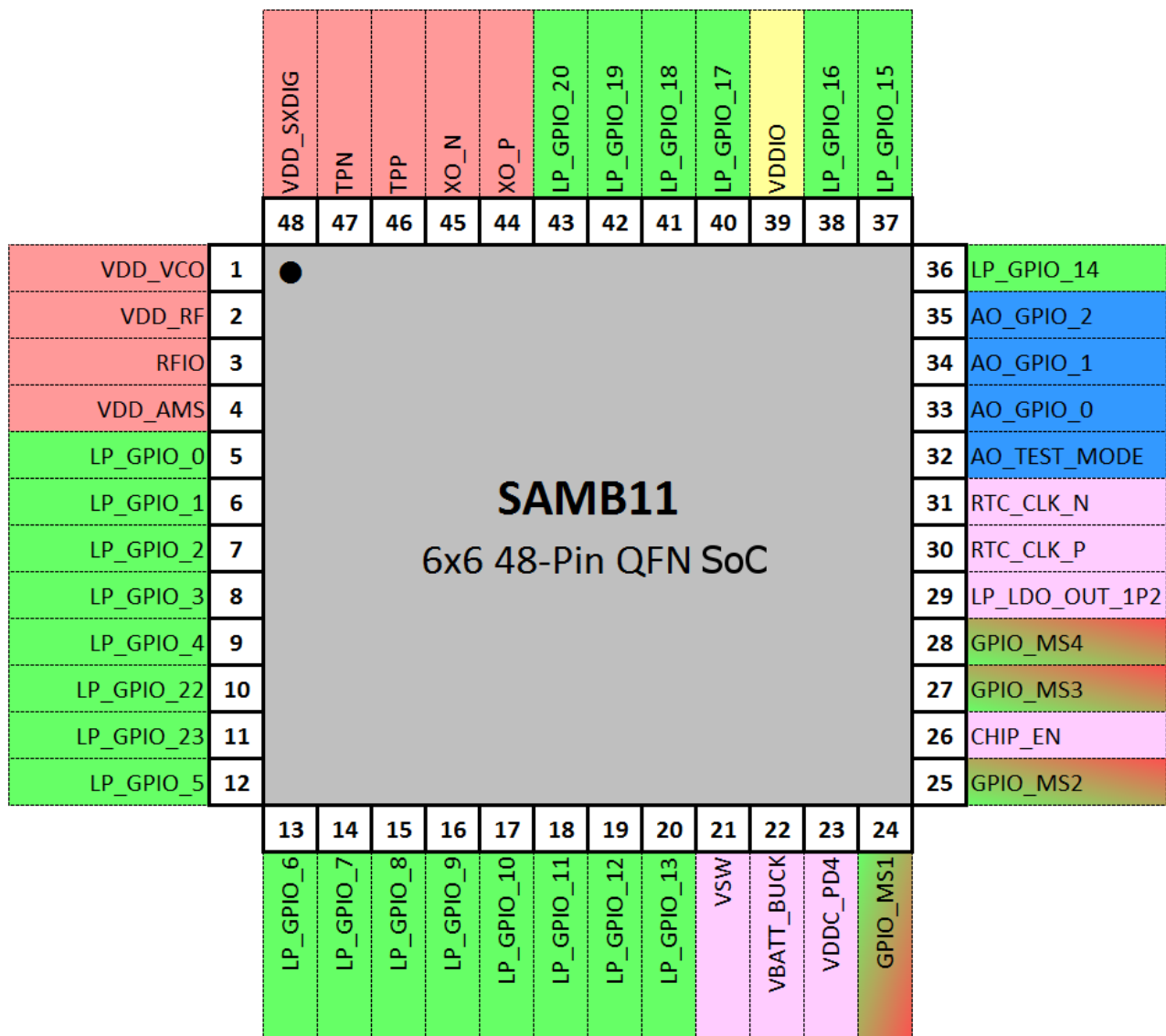

**Table 4-1. SAMB11 Pin Description with Default Peripheral Mapping**

Pin #	Pin Name	Pin Type	Description / Default Function
1	VDD_VCO	Analog/RF	RF Supply 1.2V
2	VDD_RF	Analog/RF	RF Supply 1.2V
3	RFIO	Analog/RF	RX input and TX output
4	VDD_AMS	Analog/RF	AMS Supply 1.2V
5	LP_GPIO_0	Digital I/O, Programmable Pull-Up/Down	SWD Clock
6	LP_GPIO_1	Digital I/O, Programmable Pull-Up/Down	SWD I/O
7	LP_GPIO_2	Digital I/O, Programmable Pull-Up/Down	UART1 RXD
8	LP_GPIO_3	Digital I/O, Programmable Pull-Up/Down	UART1 TXD
9	LP_GPIO_4	Digital I/O, Programmable Pull-Up/Down	UART1 CTS
10	LP_GPIO_22	Digital I/O, Programmable Pull-Up/Down	GPIO
11	LP_GPIO_23	Digital I/O, Programmable Pull-Up/Down	GPIO
12	LP_GPIO_5	Digital I/O, Programmable Pull-Up/Down	UART1 RTS
13	LP_GPIO_6	Digital I/O, Programmable Pull-Up/Down	UART2 RXD
14	LP_GPIO_7	Digital I/O, Programmable Pull-Up/Down	UART2 TXD
15	LP_GPIO_8	Digital I/O, Programmable Pull-Up/Down	I2C0 SDA (high-drive pad, see <a href="#">Table 13-3</a> )
16	LP_GPIO_9	Digital I/O, Programmable Pull-Up/Down	I2C0 SCL (high-drive pad, see <a href="#">Table 13-3</a> )
17	LP_GPIO_10	Digital I/O, Programmable Pull-Up/Down	SPI0 SCK
18	LP_GPIO_11	Digital I/O, Programmable Pull-Up/Down	SPI0 MOSI
19	LP_GPIO_12	Digital I/O, Programmable Pull-Up/Down	SPI0 SSN
20	LP_GPIO_13	Digital I/O, Programmable Pull-Up/Down	SPI0 MISO
21	VSW	PMU	DC/DC Converter Switching Node
22	VBATT_BUCK	PMU	DC/DC Converter Supply and General Battery Connection
23	VDDC_PD4	PMU	DC/DC Converter 1.2V output and feedback node
24	GPIO_MS1	Mixed Signal I/O, Programmable Pull-Up/Down	Configurable to be a GPIO Mixed Signal only (ADC interface)



Pin #	Pin Name	Pin Type	Description / Default Function
25	GPIO_MS2	Mixed Signal I/O, Programmable Pull-Up/Down	Configurable to be a GPIO Mixed Signal only (ADC interface)
26	CHIP_EN	PMU	Master Enable for chip
27	GPIO_MS3	Mixed Signal I/O, Programmable Pull-Up/Down	Configurable to be a GPIO Mixed Signal only (ADC interface)
28	GPIO_MS4	Mixed Signal I/O, Programmable Pull-Up/Down	Configurable to be a GPIO Mixed Signal only (ADC interface)
29	LP_LDO_OUT_1P2	PMU	Low Power LDO output (connect to 1µF decoupling cap)
30	RTC_CLK_P	PMU	RTC terminal + / 32.768kHz XTAL +
31	RTC_CLK_N	PMU	RTC terminal - / 32.768kHz XTAL +
32	AO_TEST_MODE	Digital Input	Test Mode Selection (SCAN ATE) /GND for normal operation
33	AO_GPIO_0	Digital I/O, Programmable Pull-Up	Always On External Wakeup
34	AO_GPIO_1	Digital I/O, Programmable Pull-Up	Always On External Wakeup
35	AO_GPIO_2	Digital I/O, Programmable Pull-Up	Always On External Wakeup
36	LP_GPIO_14	Digital I/O, Programmable Pull-Up/Down	UART2 CTS
37	LP_GPIO_15	Digital I/O, Programmable Pull-Up/Down	UART2 RTS
38	LP_GPIO_16	Digital I/O, Programmable Pull-Up/Down	GPIO
39	VDDIO	I/O Power	I/O Supply can be less than or equal to VBATT_BUCK
40	LP_GPIO_17	Digital I/O, Programmable Pull-Up/Down	GPIO
41	LP_GPIO_18	Digital I/O, Programmable Pull-Up/Down	GPIO
42	LP_GPIO_19	Digital I/O, Programmable Pull-Up/Down	GPIO
43	LP_GPIO_20	Digital I/O, Programmable Pull-Up/Down	GPIO
44	XO_P	Analog/RF	XO Crystal +
45	XO_N	Analog/RF	XO Crystal -
46	TPP	Analog/RF	Test MUX + output
47	TPN	Analog/RF	Test MUX – output
48	VDD_SXDIG	Analog/RF	RF Supply 1.2V

# 5 Package drawing

The SAMB11 QFN package is RoHS/green compliant.

Figure 5-1. SAMB11 6x6 QFN 48 Package Outline Drawing

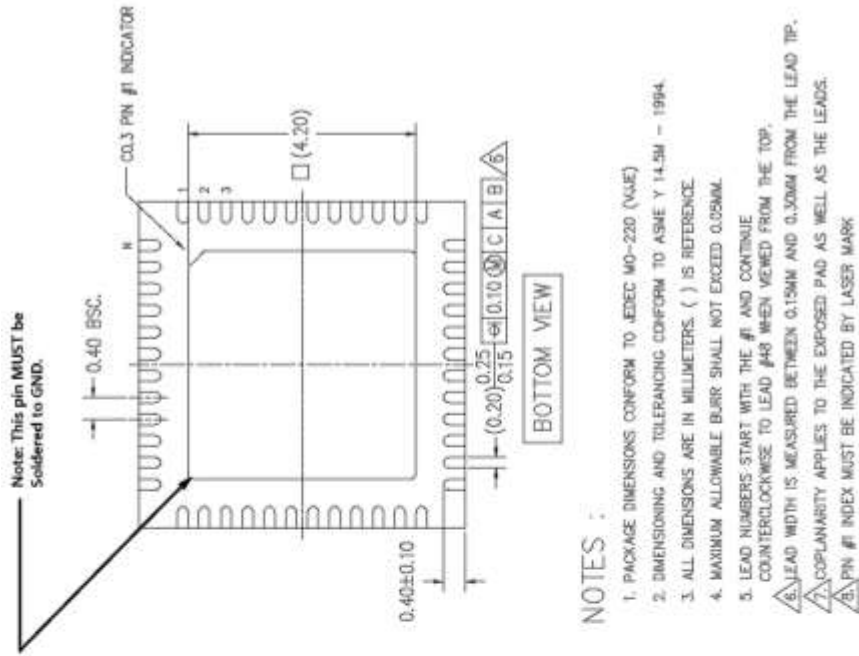

- NOTES :
1. PACKAGE DIMENSIONS CONFORM TO JEDEC MO-220 (N/AE)
  2. DIMENSIONING AND TOLERANCING CONFORM TO ASME Y 14.5M - 1994.
  3. ALL DIMENSIONS ARE IN MILLIMETERS. ( ) IS REFERENCE.
  4. MAXIMUM ALLOWABLE BURR SHALL NOT EXCEED 0.05MM.
  5. LEAD NUMBERS START WITH THE #1 AND CONTINUE COUNTERCLOCKWISE TO LEAD #48 WHEN VIEWED FROM THE TOP.
- △ LEAD WIDTH IS MEASURED BETWEEN 0.15MM AND 0.30MM FROM THE LEAD TIP.  
 ▽ COPLANARITY APPLIES TO THE EXPOSED PAD AS WELL AS THE LEADS.  
 ▹ PIN #1 INDEX MUST BE INDICATED BY LASER MARK

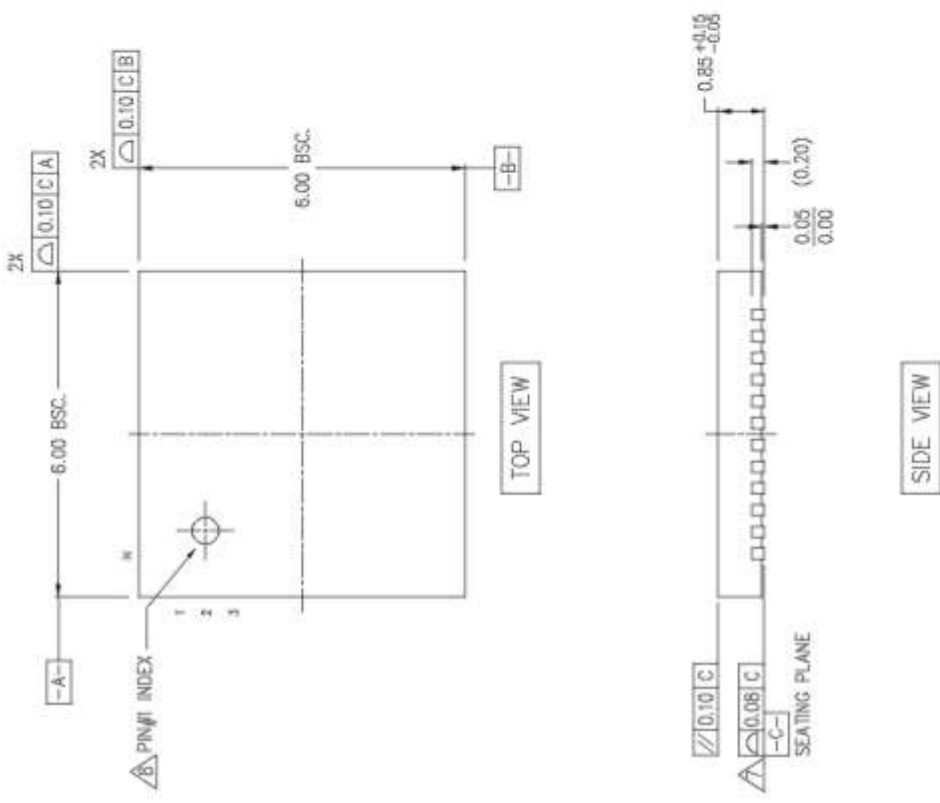

## 6 Power Management

### 6.1 Power Architecture

SAMB11 uses an innovative power architecture to eliminate the need for external regulators and reduce the number of off-chip components. The integrated power management block includes a DC/DC buck converter and separate Low Dropout (LDO) regulators for different power domains. The DCDC buck converter converts battery voltage to a lower internal voltage for the different circuit blocks and does this with high efficiency. The DCDC requires three external components for proper operation (two inductors L 4.7 $\mu$ H and 9.1nH, and one capacitor C 4.7 $\mu$ F).

The stacked Flash has a supply pin that is internally connected to the VDDIO pin.

Figure 6-1. SAMB11 Power Architecture

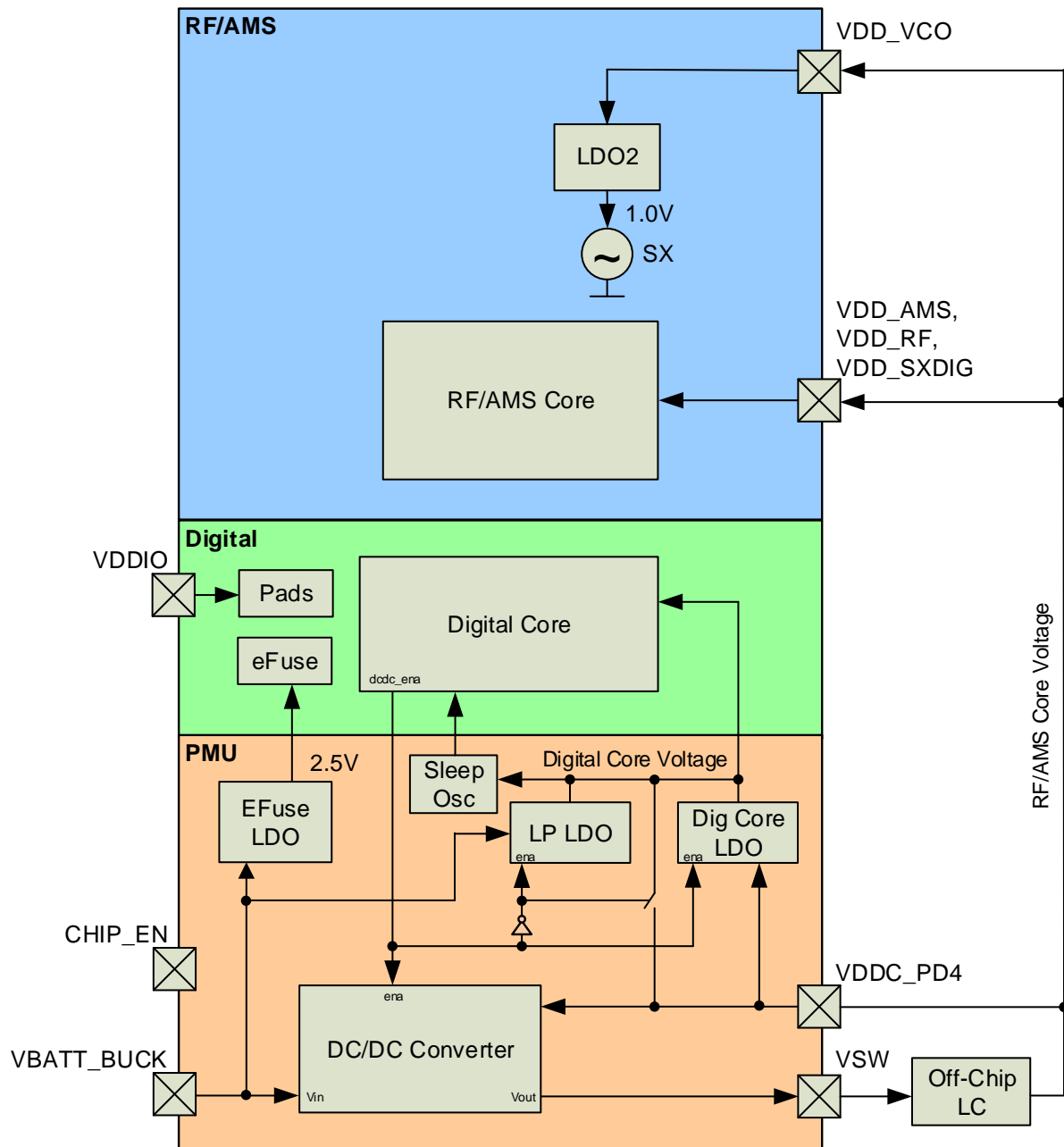

## 6.2 DC/DC Converter

The DC/DC Converter is intended to supply current to the BLE digital core and the RF transceiver core. The DC/DC consists of a power switch, 26MHz RC oscillator, controller, external inductor, and an external capacitor. The DCDC is utilizing pulse skipping discontinuous mode as its control scheme. The DC/DC specifications are shown in the following tables and charts.

**Table 6-1. DC/DC Converter Specifications (performance is guaranteed for 4.7µF L and 4.7µF C)**

Parameter	Symbol	Min.	Typ.	Max.	Unit	Note
Output current capability	I <sub>REG</sub>	0	10	30	mA	Dependent on external component values and DC/DC settings with acceptable efficiency
External capacitor range (1)	C <sub>EXT</sub>	4.7 - 10%	4.7	20	µF	External capacitance range
External inductor range	L <sub>EXT</sub>	2.2 - 10%	4.7	4.7 +10%	µH	External inductance range
Battery voltage	V <sub>BAT</sub>	2.3	3.3	4.3	V	Functionality and stability given
Output voltage range	V <sub>REG</sub>	1.05	1.2	1.47		25mV step size
Current consumption	I <sub>DD</sub>		125		µA	DC/DC quiescent current
Startup time	t <sub>startup</sub>	50		600	µs	Dependent on external component values and DC/DC settings
Voltage ripple	ΔV <sub>REG</sub>	5	10	30	mV	Dependent on external component values and DC/DC settings
Efficiency	η		85		%	Measured at 3V V <sub>BATT</sub> , at load of 10mA
Overshoot at startup	V <sub>OS</sub>		0		mV	No overshoot, no output pre-charge
Line Regulation	ΔV <sub>REG</sub>		10			From 2.35 - 4.3V
Load regulation	ΔV <sub>REG</sub>		5			From 0 - 10mA

Note: 1. External Cap: Sum of all caps connected to the DC/DC output node.

**Table 6-2. DC/DC Converter Allowable Onboard Inductor and Capacitor Values (V<sub>BATT</sub>=3V)**

Inductor [µH]	Efficiency [%]	V <sub>ripple</sub> [mV]			RX sensitivity <sup>(1)</sup> [dBm]
		C=2.2µF	C=4.7µF	C=10µF	
2.2	83	N/A	<5	<5	~1.5dB degrade
4.7	85	9	5	<5	~0.7dB degrade

Note: 1. Degradation relative to design powered by external LDO and DC/DC disabled.

Figure 6-2. DC/DC Converter Efficiency

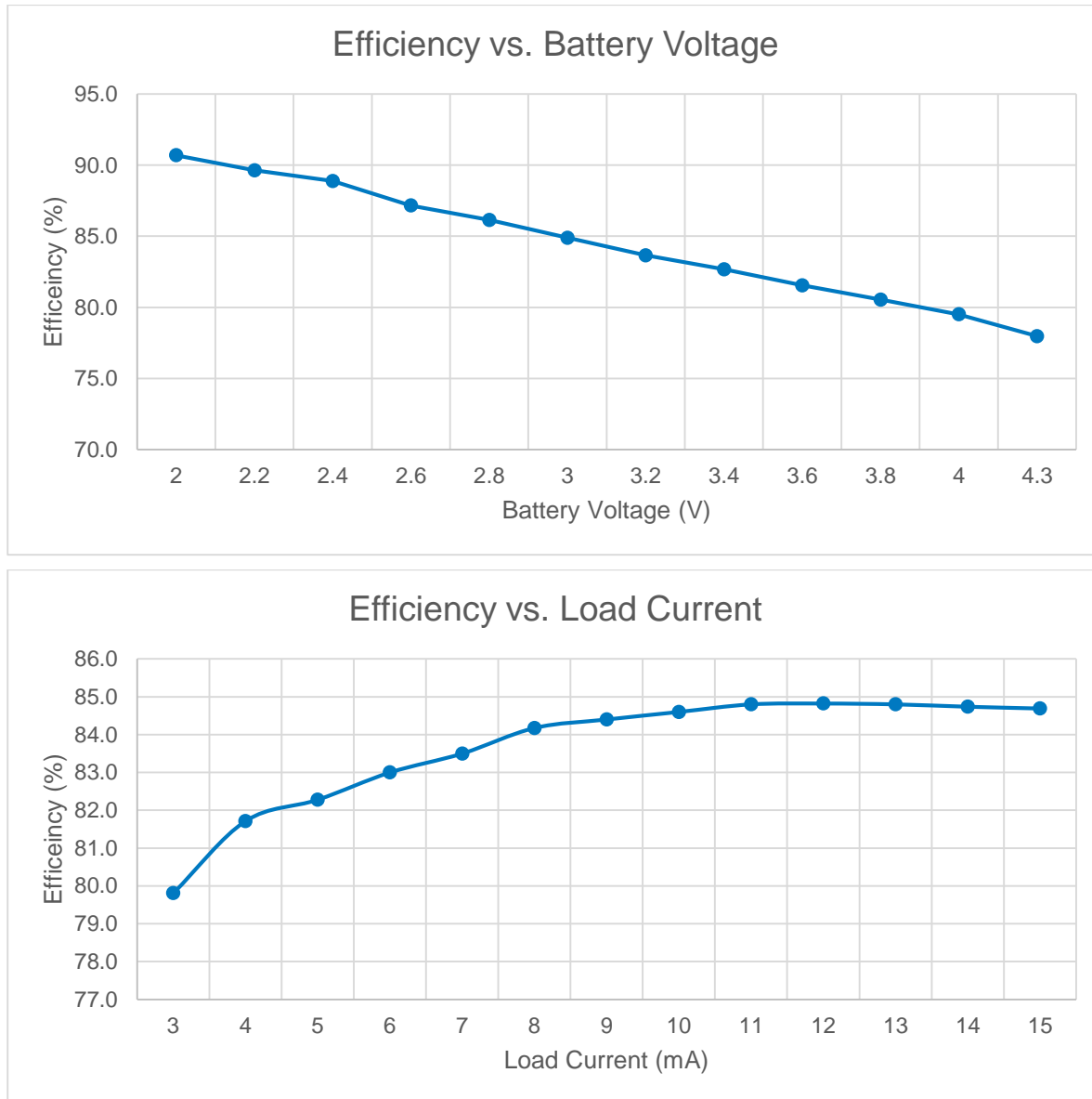

## 6.3 Power Consumption

### 6.3.1 Description of Device States

SAMB11 has multiple device states, depending on the state of the ARM processor and BLE subsystem.

Note: The ARM is required to be powered ON if the BLE subsystem is active.

- BLE\_On\_Transmit – Device is actively transmitting a BLE signal (Application may or may not be active)
- BLE\_On\_Receive – Device is actively receiving a BLE signal (Application may or may not be active)
- MCU\_Only – Device has ARM processor powered on and BLE subsystem powered down
- Ultra\_Low\_Power – BLE is powered down and Application is powered down (with or without RAM retention)
- Power\_Down – Device core supply off

### 6.3.2 Controlling the Device States

The following pins are used to switch between the main device states:

- CHIP\_EN – Used to enable PMU
- VDDIO – I/O supply voltage from external supply

In Power\_Down state, VDDIO is on and CHIP\_EN is low (at GND level). To switch between Power\_Down state and MCU\_Only state CHIP\_EN has to change between low and high (VDDIO voltage level). Once the device is the MCU\_Only state, all other state transitions are controlled entirely by software. When VDDIO is off and CHIP\_EN is low, the chip is powered off with no leakage.

When no power is supplied to the device (the DC/DC Converter output and VDDIO are both off and at ground potential), a voltage cannot be applied to the SAMB11 pins because each pin contains an ESD diode from the pin to supply. This diode will turn on when a voltage higher than one diode-drop is supplied to the pin.

If a voltage must be applied to the signal pads while the chip is in a low power state, the VDDIO supply must be on, so the Power\_Down state must be used. Similarly, to prevent the pin-to-ground diode from turning on, do not apply a voltage that is more than one diode-drop below ground to any pin.

### 6.3.3 Current Consumption in Various Device States

**Table 6-3. SAMB11 Device Current Consumption**

Device State	CHIP_EN	VDDIO	I <sub>VBATT</sub> (typical)	I <sub>VDDIO</sub> (typical)	Remark
Power_Down	Off	On	<50nA	<50nA	
Ultra_Low_Power Standby	On	On	900nA	50nA	
Ultra_Low_Power with 8KB retention, BLE timer, no RTC <sup>(1)</sup>	On	On	1.1µA	0.2µA	
Ultra_Low_Power with 8KB retention, BLE timer, with RTC <sup>(2)</sup>	On	On	1.25µA	0.1uA	
MCU_Only, idle (waiting for interrupt)	On	On	0.85mA	12µA	
BLE_On_Receive@-95dBm	On	On	4.5mA	12µA	
BLE_On_Transmit, 0dBm output power	On	On	3.0mA	12µA	
BLE_On_Transmit, 3.5dBm output power	On	On	4.0mA	12µA	

- Notes:
1. Sleep clock derived from internal 32kHz RC oscillator.
  2. Sleep clock derived from external 32.768kHz crystal specified for C<sub>L</sub>=7pF, using the default on-chip capacitance only, without using external capacitance.

Note: The average advertising current for connectable beacon with a full payload (37-byte packet) is targeted to be 9.7µA. The average advertising current is based on automatic advertising from the ROM with RTC 32kHz, BLE sleep timers, and 8KB memory retention. IDRAM1 and IDRAM2 are OFF. External Peripherals and debug clocks are turned OFF. VBATT is set to 3.6V. This advertising current will be enabled in a future SDK release. For current SDK based advertising current, see errata Chapter 14.

Figure 6-3. SAMB11 Average Advertising Current

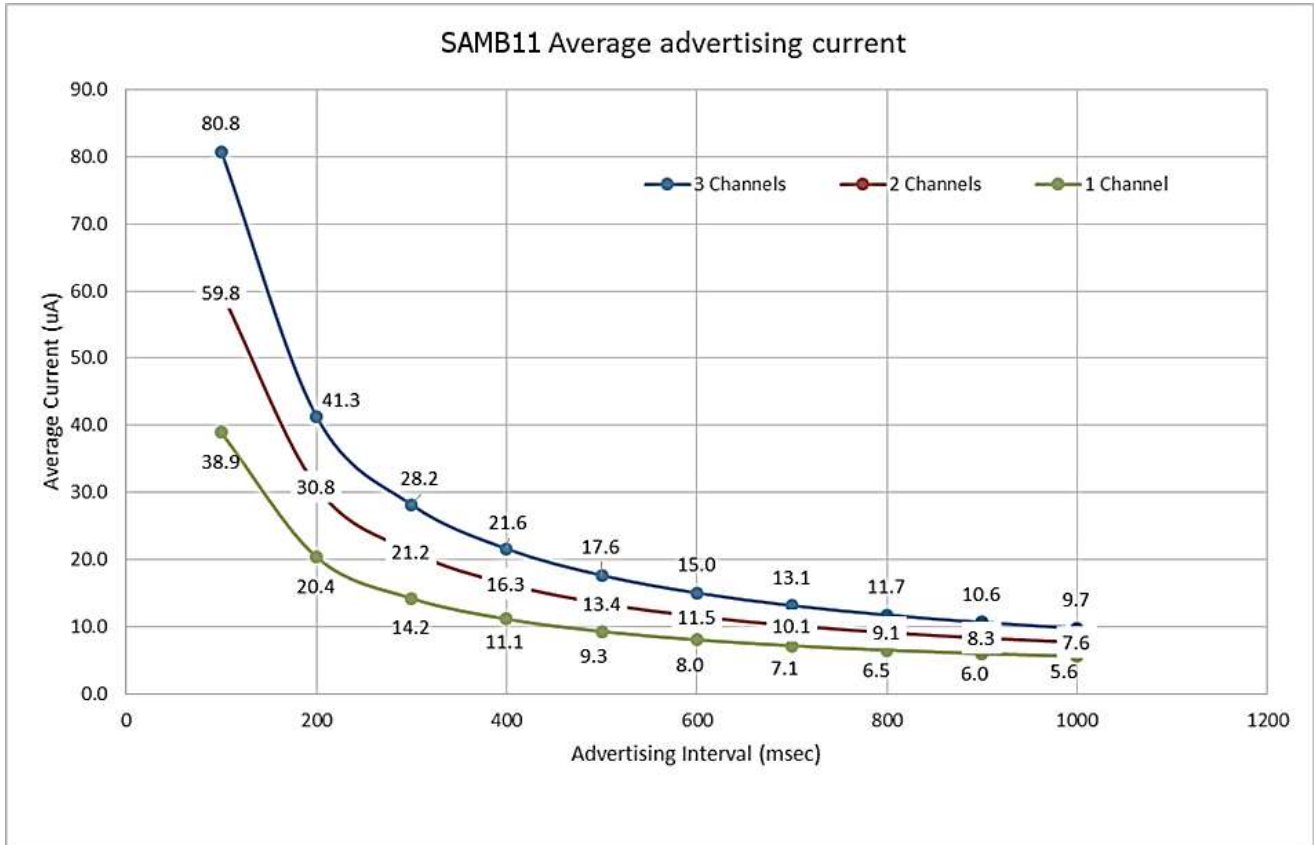

## 6.4 Power-up Sequence

The power-up sequence for SAMB11 is shown in Figure 6-4. The timing parameters are provided in Table 6-4.

Figure 6-4. SAMB11 Power-up Sequence

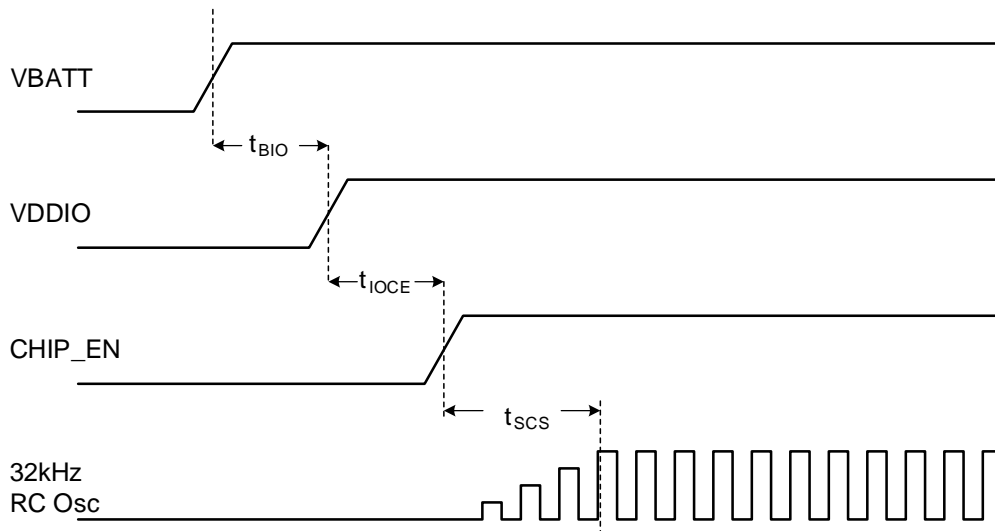

**Table 6-4. SAMB11 Power-up Sequence Timing**

Parameter	Min.	Max.	Units	Description	Notes
t <sub>BIO</sub>	0		ms	VBATT rise to VDDIO rise	VBATT and VDDIO can rise simultaneously or can be tied together.
t <sub>IOCE</sub>	0			VDDIO rise to CHIP_EN rise	CHIP_EN must not rise before VDDIO. CHIP_EN must be driven high or low, not left floating.
t <sub>scs</sub>	10		μs	CHIP_EN rise to 31.25kHz (2MHz/64) oscillator stabilizing	

## 6.5 Power On Reset (POR) and Brown Out Detector (BOD)

The SAMB11 has a POR circuit for proper system power bring up and a brown-out detector to reset the system's operation when a drop in battery voltage is detected.

- POR is a power on reset circuit that outputs a HI logic value when the VBATT\_BUCK is below a voltage threshold. The POR output becomes a LO logic value when the VBATT\_BUCK is above a voltage threshold.
- BOD is a brown out detector that outputs a HI logic value when the bandgap reference (BGR) voltage falls below a programmable voltage threshold. When the bandgap voltage reference voltage level is restored above a voltage threshold, the BOD output becomes a LO logic value.
- The counter creates a pulse that is HI for  $256 \cdot (64 \cdot T_{2MHz}) \sim 8.2ms$

The system block diagram and timing are illustrated in [Figure 6-5](#) and [Figure 6-6](#).

[Table 6-5](#) shows the BOD thresholds.

**Figure 6-5. SAMB11 POR and BOD Block Diagram**

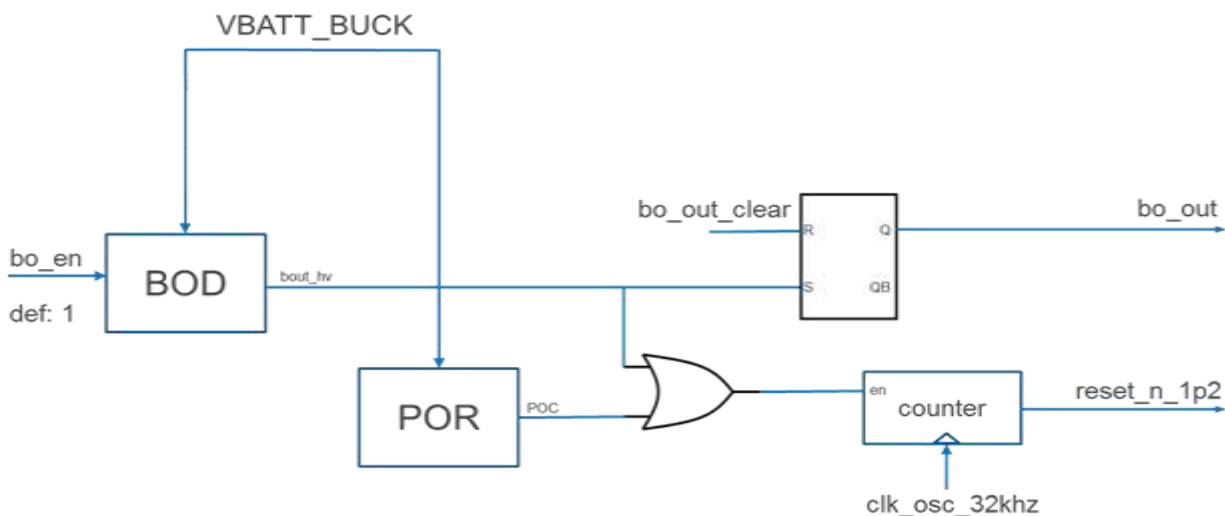



**Figure 6-6. SAMB11 POR and BOD Timing Sequence**

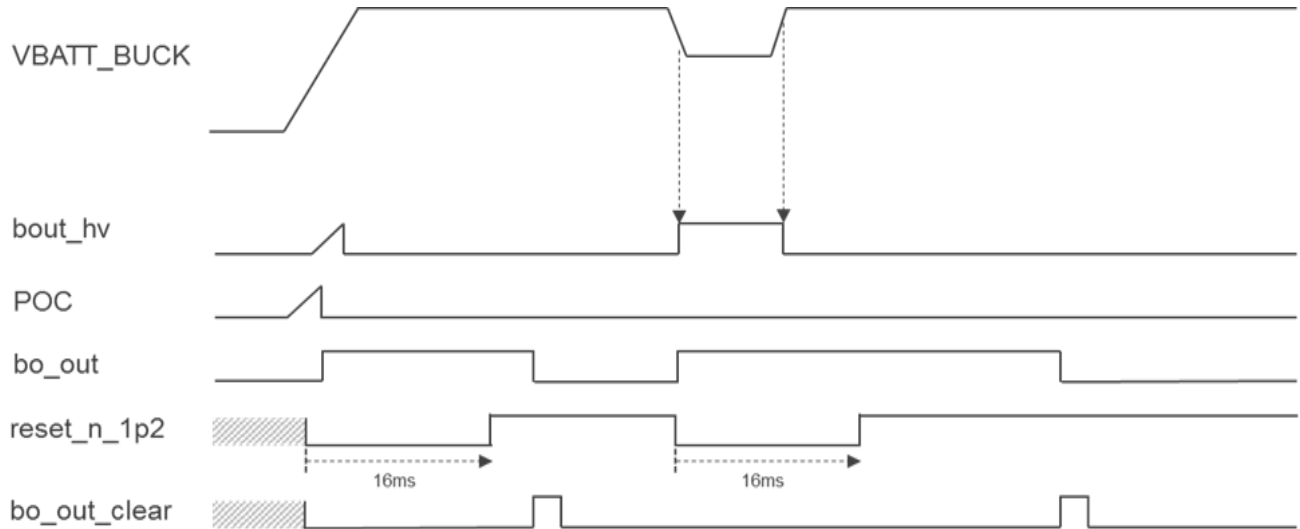

**Table 6-5. ATBTLC1000 BOD Thresholds**

Parameter	Min.	Typ.	Max.	Comment
BOD threshold	1.73V	1.80V	1.92V	
BOD threshold temperature coefficient		-1.09mV/C		
BOD current consumption		300nA		
t <sub>POR</sub>		8.2ms		

## 6.6 Digital and Mixed-Signal I/O Pin Behavior during Power-Up Sequences

The following table represents I/O pin states corresponding to device power modes.

**Table 6-6. I/O Pin Behavior in Different Device States<sup>1</sup>**

Device State	VDDIO	CHIP_EN	Output Driver	Input Driver	Pull Up/Down Resistor <sup>2</sup>
Power_Down: core supply off	High	Low	Disabled (Hi-Z)	Disabled	Disabled
Power-On Reset: core supply on, POR hard reset pulse on	High	High	Disabled (Hi-Z)	Disabled	Disabled <sup>3</sup>
Power-On Default: core supply on, device out of reset but not programmed yet	High	High	Disabled (Hi-Z)	Enabled <sup>4</sup>	Enabled Pull-Up <sup>4</sup>
MCU_Only, BLE_On: core supply on, device pro- grammed by firmware	High	High	Programmed by firm- ware for each pin: Enabled or Disabled (Hi-Z) <sup>5</sup> , when Enabled driving 0 or 1	Opposite of Out- put Driver state: Disabled or Ena- bled <sup>5</sup>	Programmed by firm- ware for each pin: Enabled or Disabled, Pull-Up or Pull-Down <sup>5</sup>

Device State	VDDIO	CHIP_EN	Output Driver	Input Driver	Pull Up/Down Resistor <sup>2</sup>
Ultra_Low_Power: core supply on for always-on domain, core supply off for switchable domains	High	High	Retains previous state <sup>6</sup> for each pin: Enabled or Disabled (Hi-Z), when Enabled driving 0 or 1	Opposite of Output Driver state: Disabled or Enabled <sup>5</sup>	Retains the previous state <sup>6</sup> for each pin: Enabled or Disabled, Pull-Up or Pull-Down

- Notes:
1. This table applies to all three types of I/O pins (digital switchable domain GPIOs, digital always-on/wakeup GPIOs, and mixed-signal GPIOs) unless otherwise noted
  2. Pull-up/down resistor value is 96kΩ ±10%
  3. In Power-On Reset state pull-up resistor is enabled in the always-on/wakeup GPIOs only
  4. In Power-On Default state input drivers and pull-up/down resistors are disabled in the mixed-signal GPIOs only (mixed-signal GPIOs are defaulted to analog mode, see the note below)
  5. Mixed-signal GPIOs can be programmed to be in analog or digital mode for each pin: when programmed to analog mode (default), the output driver, input driver, and pull-up/down resistors are all disabled
  6. In Ultra\_Low\_Power state always-on/wakeup GPIOs do not have retention capability and behave same as in MCU\_Only or BLE\_On states, also for mixed-signal GPIOs programming analog mode overrides retention functionality for each pin

# 7 Clocking

## 7.1 Overview

Figure 7-1. SAMB11 Clock Architecture

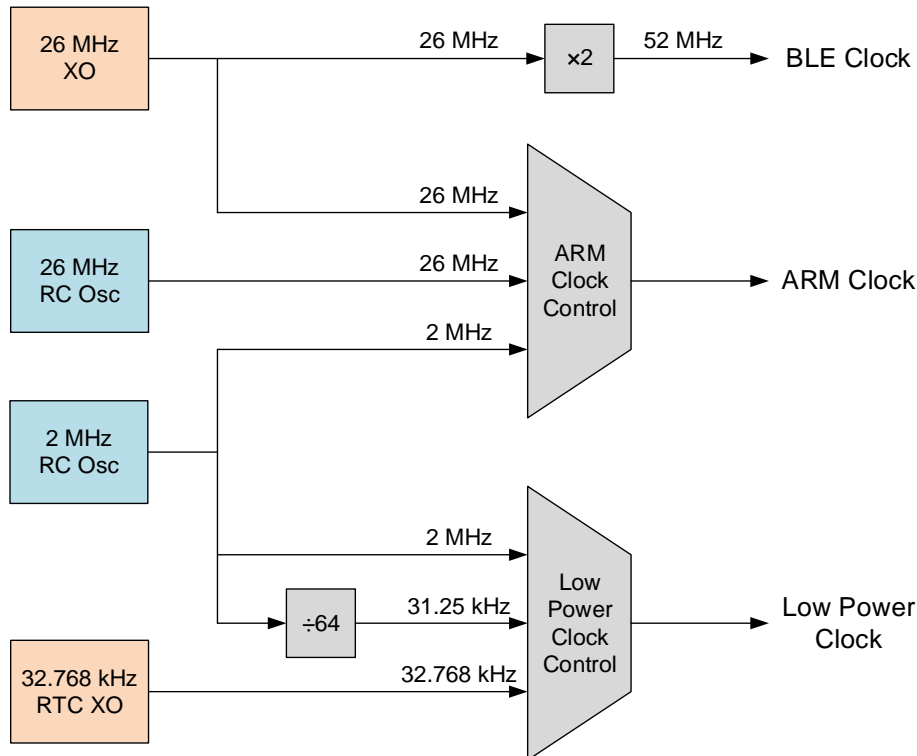

Figure 7-1 provides an overview of the clock tree and clock management blocks.

The BLE Clock is used to drive the BLE subsystem. The ARM clock is used to drive the Cortex-M0 MCU and its interfaces (UART, SPI, and I<sup>2</sup>C), the nominal MCU clock speed is 26MHz. The Low Power Clock is used to drive all the low power applications like the BLE sleep timer, always-on power sequencer, always-on timer, and others.

The 26MHz Crystal Oscillator (XO) must be used for the BLE operations or in the event a very accurate clock is required for the ARM subsystem operations.

The 26MHz integrated RC Oscillator is used for most general purpose operations on the MCU and its peripherals. In cases when the BLE subsystem is not used, the RC oscillator can be used for lower power consumption. The frequency variation of this RC oscillator is up to  $\pm 50\%$  over process, voltage, and temperature.

The 2MHz integrated RC Oscillator can be used as the Low Power Clock for applications that require a fast wake up of the ARM or for generating a  $\sim 31.25$  kHz clock for a slower wake up but lowest power in sleep mode. This 2MHz oscillator can also be used as the ARM Clock for low-power applications where the MCU needs to remain on but run at a reduced clock speed. The frequency variation of this RC oscillator is up to  $\pm 50\%$  over process, voltage, and temperature.

The 32.768kHz RTC Crystal Oscillator (RTC XO) is recommended to be used for BLE operations (although optional) as it will reduce power consumption by providing the best timing for wake up precision, allowing circuits to be in low power sleep mode for as long as possible until they need to wake up and connect during the BLE connection event. The  $\sim 31.25$ kHz clock derived from the 2MHz integrated RC Oscillator can be used instead of RTC XO but it has low accuracy over process, voltage and temperature variations (up to  $\pm 50\%$ ) and thus needs to

be frequently calibrated to within  $\pm 500$ ppm if the RC oscillator is used for BLE timing during a connection event. Because this clock is less accurate than RTC XO, it will require waking up earlier to prepare for a connection event and this will increase the average power consumption. Calibration of the RC Oscillator is described in the application note.

## 7.2 26MHz Crystal Oscillator (XO)

**Table 7-1. SAMB11 26MHz Crystal Oscillator Parameters**

Parameter	Min.	Typ.	Max.	Units
Crystal Resonant Frequency	N/A	26	N/A	MHz
Crystal Equivalent Series Resistance		50	80	$\Omega$
Stability - Initial Offset <sup>(1)</sup>	-50		50	ppm
Stability - Temperature and Aging	-40		40	ppm

Note: 1. The initial offset must be calibrated to maintain  $\pm 25$ ppm in all operating conditions. This calibration is performed during final production testing and calibration offset values are stored in eFuse. More details are provided in the calibration application note.

The block diagram in [Figure 7-2\(a\)](#) shows how the internal Crystal Oscillator (XO) is connected to the external crystal.

The XO has up to 10pF internal capacitance on each terminal XO\_P and XO\_N (programmable in steps of 1.25pF). To bypass the crystal oscillator, an external Signal capable of driving 10pF can be applied to the XO\_P terminal as shown in [Figure 7-2\(b\)](#).

The needed external bypass capacitors depend on the chosen crystal characteristics. Refer to the datasheet of the preferred crystal and take into account the on-chip capacitance.

When bypassing XO\_P from an external clock, XO\_N is required to be floating.

**Figure 7-2. SAMB11 Connections to XO**

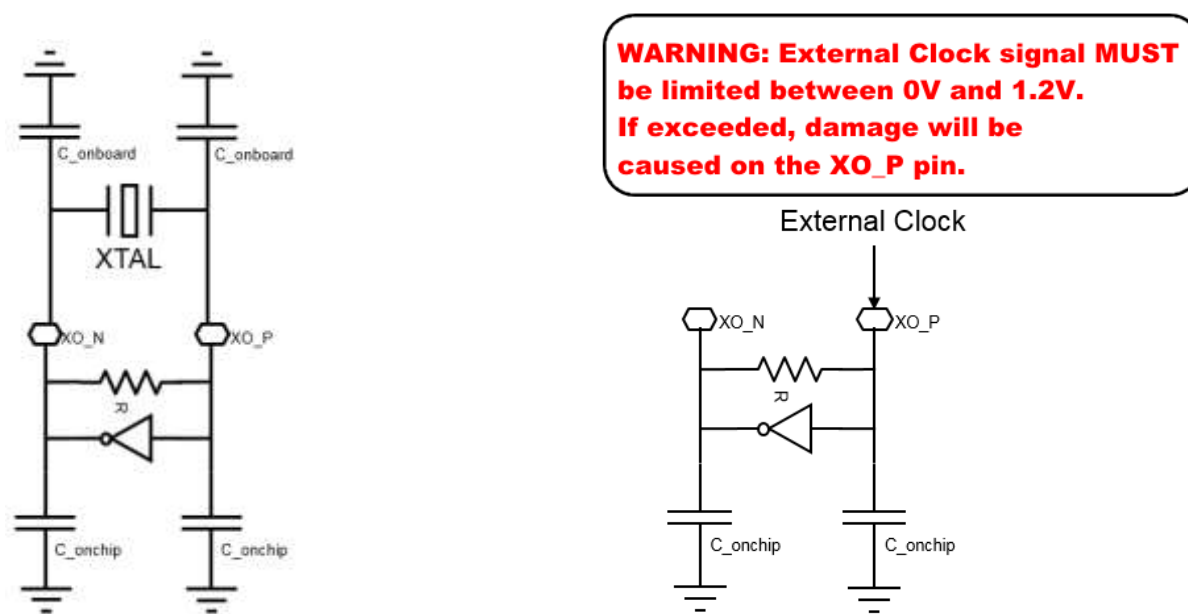

(a) Crystal oscillator is used

(b) Crystal oscillator is bypassed

**Table 7-2. SAMB11 26MHz XTAL C\_onchip Programming**

xo_cap[3:0]	40020808[17]	40020848[17]	40020814[7,6,15]	Cl,on-chip [pF]
0	0	0	000	1.00
1	0	0	001	2.25
2	0	0	010	3.50
3	0	0	011	4.75
4	0	0	100	<b>6.00</b>
5	0	0	101	7.25
6	0	0	110	8.50
7	0	0	111	9.75
8	1	1	000	6.00
9	1	1	001	7.25
10	1	1	010	8.50
11	1	1	011	9.75
12	1	1	100	11.00
13	1	1	101	12.25
14	1	1	110	13.50
15	1	1	111	14.75

Table 7-3 specifies the electrical and performance requirements for the external clock.

**Table 7-3. SAMB11 Bypass Clock Specification**

Parameter	Min.	Max.	Unit	Comments
Oscillation frequency	26	26	MHz	Must be able to drive 5pF load @ desired frequency
Voltage swing	0.75	1.2	Vpp	
Stability – Temperature and Aging	-50	+50	ppm	BLE Spec has +/-50ppm Frequency accuracy requirement.
Phase Noise		-130	dBc/Hz	At 10kHz offset
Jitter (RMS)		<1psec		Based on integrated phase noise spectrum from 1kHz to 1MHz

## 7.3 32.768kHz RTC Crystal Oscillator (RTC XO)

### 7.3.1 General Information

SAMB11 has a 32.768kHz RTC oscillator that is preferably used for BLE activities involving connection events. To be compliant with the BLE specifications for connection events, the frequency accuracy of this clock has to be within  $\pm 500$ ppm. Because of the high accuracy of the 32.768kHz crystal oscillator clock, the power consumption can be minimized by leaving radio circuits in low-power sleep mode for as long as possible until they need to wake up for the next connection timed event.

The block diagram in Figure 7-3(a) shows how the internal low-frequency Crystal Oscillator (XO) is connected to the external crystal.

The RTC XO has a programmable internal capacitance with a maximum of 15pF on each terminal, RTC\_CLK\_P, and RTC\_CLK\_N. When bypassing the crystal oscillator with an external signal, one can program down the internal capacitance to its minimum value (~1pF) for easier driving capability. The driving signal can be applied to the RTC\_CLK\_P terminal as shown in Figure 7-3(b).

The needed external bypass capacitors depend on the chosen crystal characteristics. Refer to the datasheet of the preferred crystal and take into account the on-chip capacitance.

When bypassing RTC\_CLK\_P from an external clock, RTC\_CLK\_N is required to be floating.

**Figure 7-3. SAMB11 Connections to RTC XO**

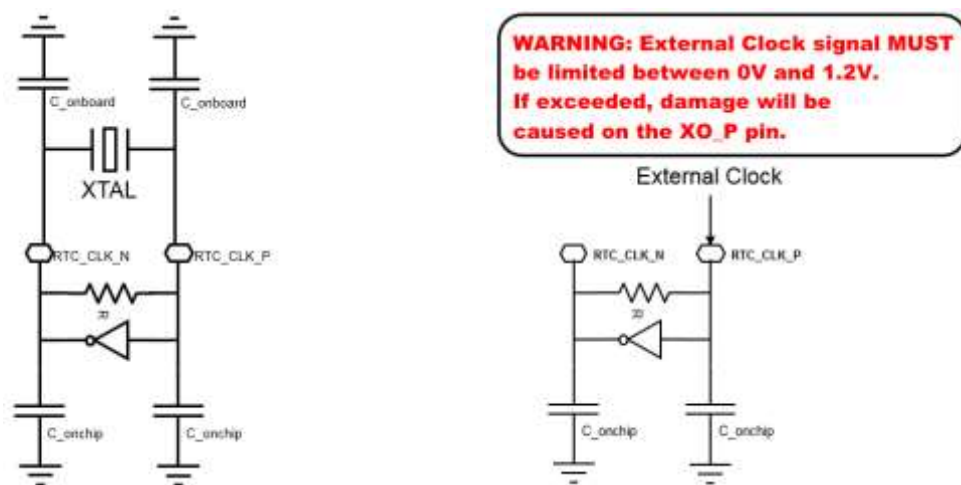

(a) Crystal oscillator is used

(b) Crystal oscillator is bypassed

**Table 7-4. 32.768kHz XTAL C\_onchip Programming**

Register: pierce_cap_ctrl[3:0]	Cl_onchip [pF]
0000	0.0
0001	1.0
0010	2.0
0011	3.0
0100	4.0
0101	5.0
0110	6.0
0111	7.0
1000	8.0
1001	9.0
1010	10.0
1011	11.0
1100	12.0
1101	13.0
1110	14.0
1111	15.0

### 7.3.2 RTC XO Design and Interface Specification

The RTC consists of two main blocks: The Programmable Gm stage and tuning capacitors. The programmable Gm stage is used to guarantee oscillation startup and to sustain oscillation. Tuning capacitors are used to adjust the XO center frequency and control the XO precision for different crystal models. The output of the XO is driven to the digital domain via a digital buffer stage with a supply voltage of 1.2V.

**Table 7-5. RTC XO Interface**

Pin Name	Function	Register Default
Digital Control Pins		
Pierce_res_ctrl	Control feedback resistance value: 0 = 20MΩ Feedback resistance 1 = 30MΩ Feedback resistance	0X4000F404<15>='1'
Pierce_cap_ctrl<3:0>	Control the internal tuning capacitors with step of 700fF: 0000=700fF 1111=11.2pF Refer to crystal datasheet to check for optimum tuning cap value	0X4000F404<23:20>="1000"
Pierce_gm_ctrl<3:0>	Controls the Gm stage gain for different crystal mode: 0011= for crystal with shunt cap of 1.2pF 1000= for crystal with shunt cap >3pF	0X4000F404<19:16>="1000"
Supply Pins		
VDD_XO	1.2V	

### 7.3.3 RTC Characterization with Gm Code Variation at Supply 1.2V and Temp. = 25°C

This section shows the RTC total drawn current and the XO accuracy versus different tuning capacitors and different GM codes, at supply voltage of 1.2V and temp. = 25°C.

**Figure 7-4. RTC Drawn Current vs. Tuning Caps at 25°C**

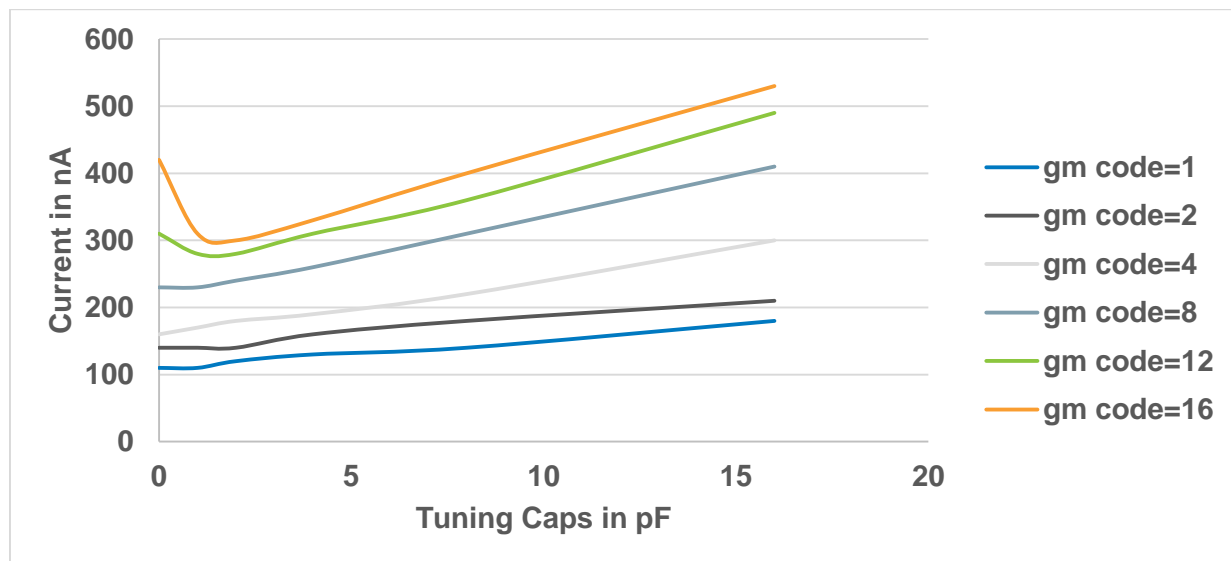
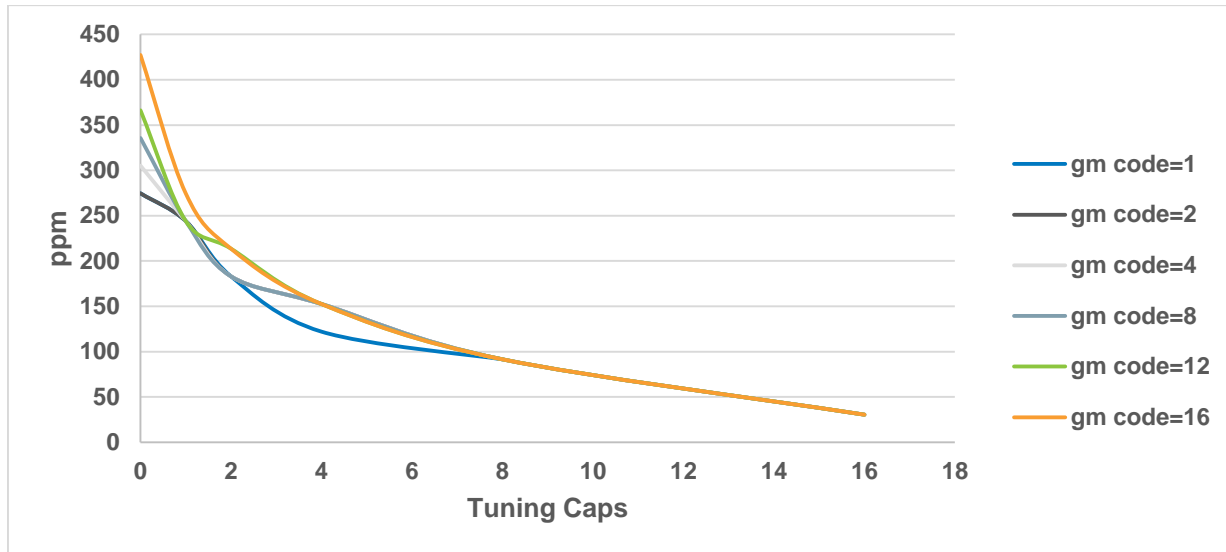

Figure 7-5. RTC Oscillation Frequency Deviation vs. Tuning Caps at 25°C



### 7.3.4 RTC Characterization with Supply Variation and Temp. = 25°C

Figure 7-6. RTC Drawn Current vs. Supply Variation

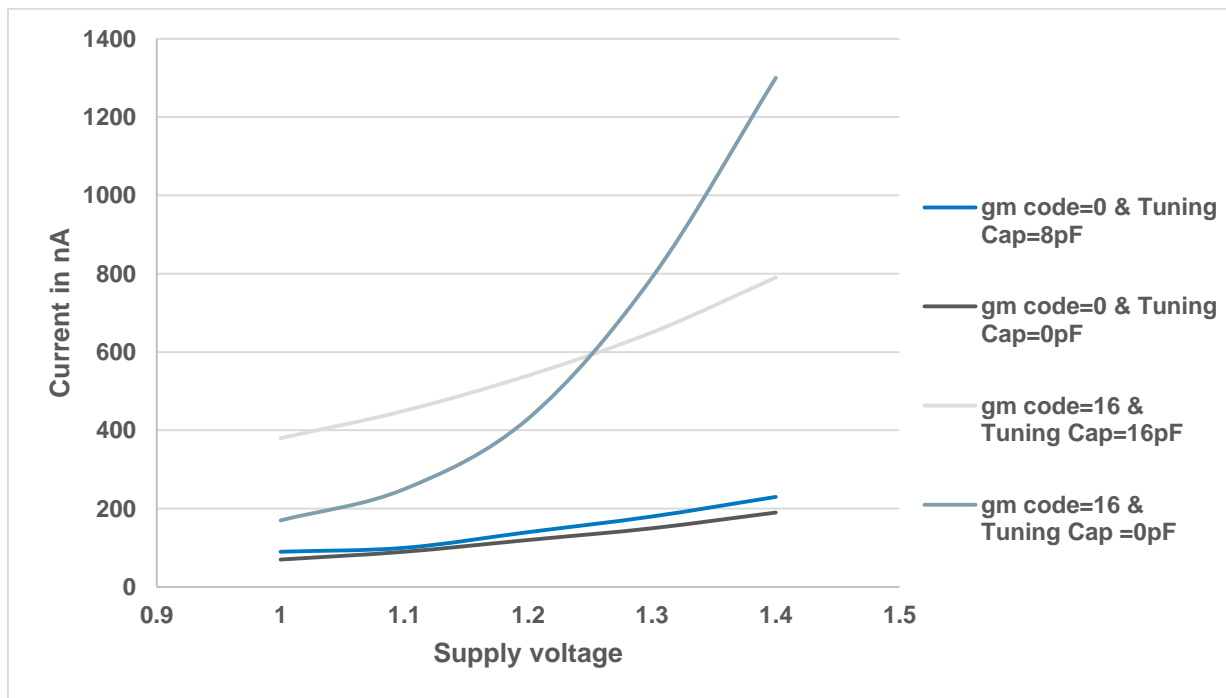
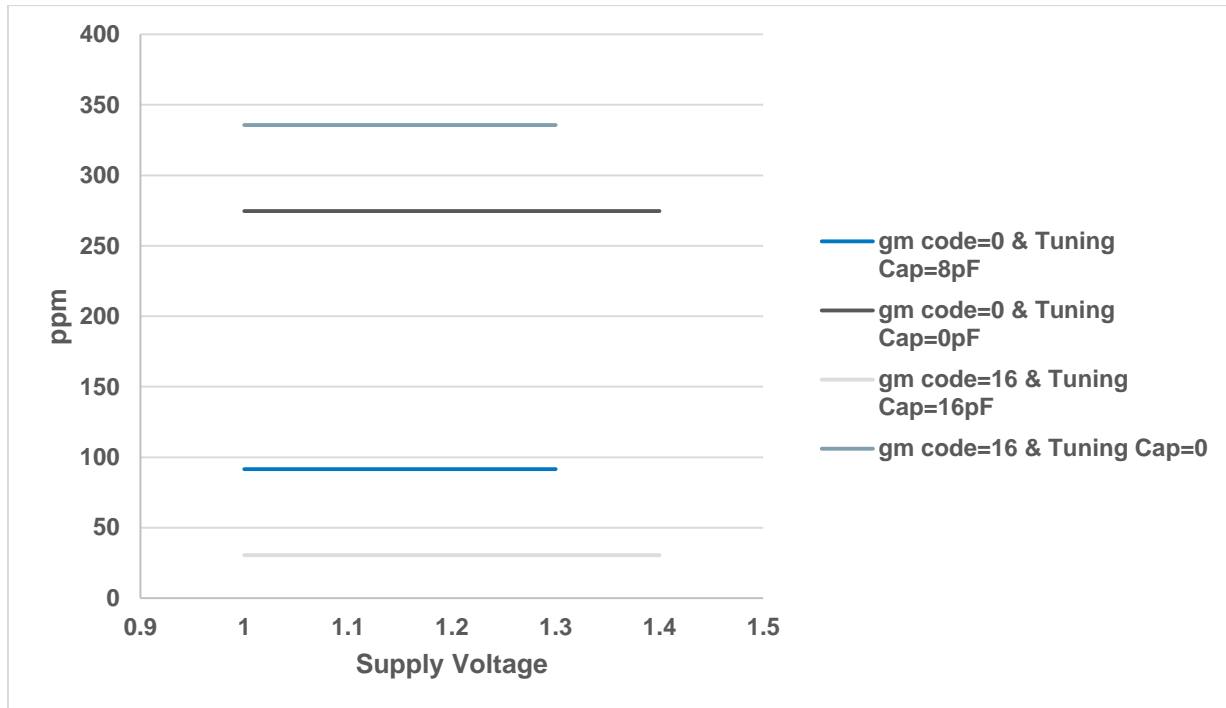



Figure 7-7. RTC Frequency Deviation vs. Supply Voltage



## 7.4 2MHz and 26MHz Integrated RC Oscillator

The 2MHz integrated RC Oscillator circuit without calibration has a frequency variation of 50% over process, temperature, and voltage variation. The ~31.25kHz clock is derived from the 2MHz clock by dividing by 64 and provides for lowest sleep power mode with a real-time clock running. As described above, calibration over process, temperature, and voltage is required to maintain the accuracy of this clock.

Figure 7-8. 32kHz RC Oscillator PPM Variation vs. Calibration Time at Room Temperature

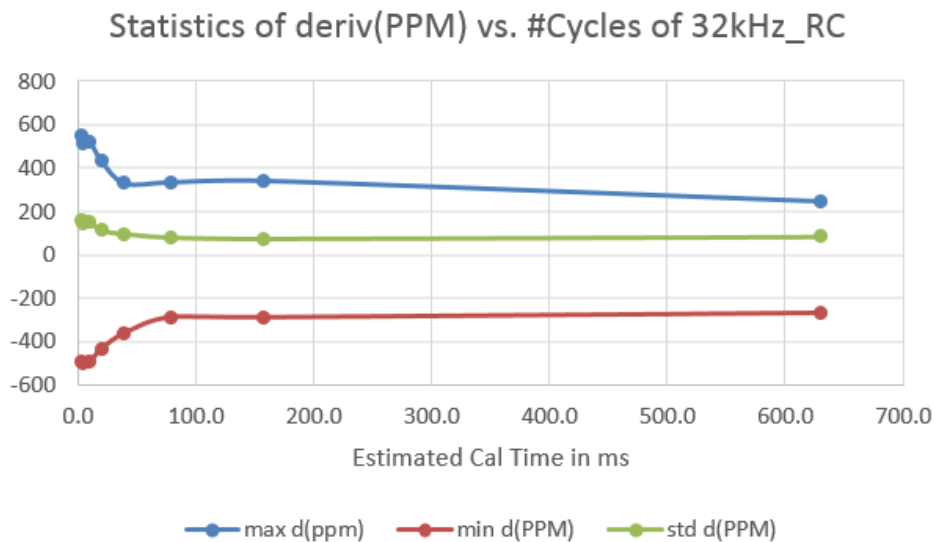
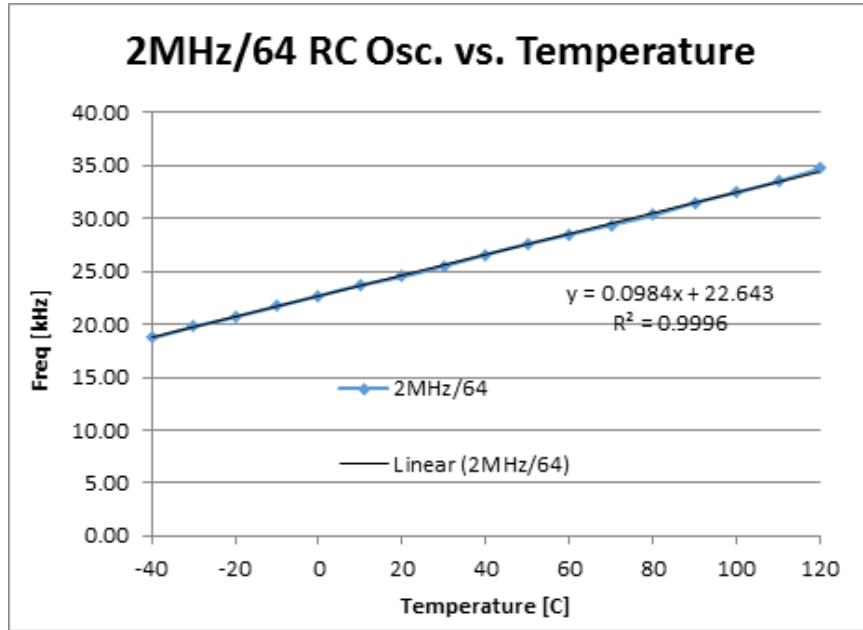

Figure 7-9. 32kHz RC Oscillator Frequency Variation over Temperature



The 26MHz integrated RC Oscillator circuit has a frequency variation of 50% over process, temperature, and voltage variation.

## 8 CPU and Memory Subsystem

### 8.1 ARM Subsystem

SAMB11 has an ARM Cortex-M0 32-bit processor. It is responsible for controlling the BLE Subsystem and handling all application features.

The Cortex-M0 Microcontroller consists of a full 32-bit processor capable of addressing 4GB of memory. It has a RISC-like load/store instruction set and internal 3-stage Pipeline Von Neumann architecture.

The Cortex-M0 processor provides a single system-level interface using AMBA technology to provide high speed, low latency memory accesses.

The Cortex-M0 processor implements a complete hardware debug solution, with four hardware breakpoint and two watchpoint options. This provides high system visibility of the processor, memory, and peripherals through a 2-pin Serial Wire Debug (SWD) port that is ideal for microcontrollers and other small package devices.

Figure 8-1. SAMB11 ARM Cortex-M0 Subsystem

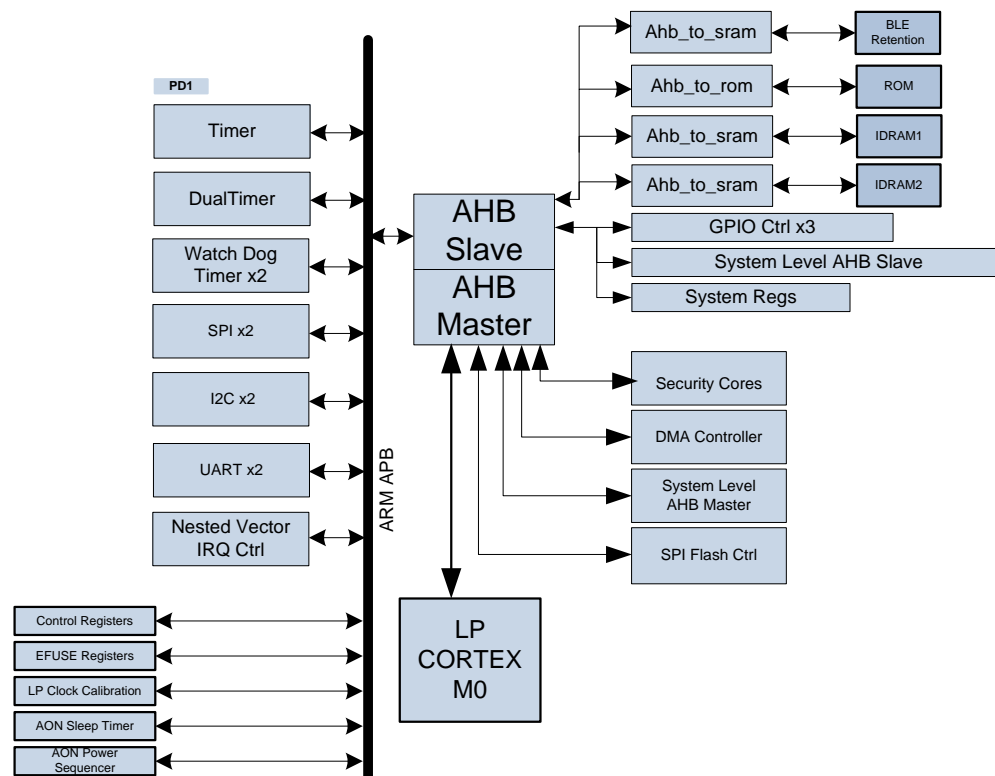

#### 8.1.2 Features

The processor features and benefits are:

- Tight integration with the system peripherals to reduce area and development costs
- Thumb instruction set combines high code density with 32-bit performance
- Integrated sleep modes using a Wakeup Interrupt Controller for low power consumption
- Deterministic, high-performance interrupt handling via Nested Vector Interrupt Controller for time-critical applications
- Serial Wire Debug reduces the number of pins required for debugging
- DMA engine for Peripheral-to-Memory, Memory-to-Memory and Memory-to-Peripheral operation

## 8.1.3 Module Descriptions

### 8.1.3.1 Timer

The 32 bit timer block allows the CPU to generate a time tick at a programmed interval. This feature can be used for a wide variety of functions such as counting, interrupt generation, and time tracking.

### 8.1.3.2 Dual Timer

The APB dual-input timer module is an APB slave module consisting of two programmable 32-bit down-counters that can generate interrupts when they expire. The timer can be used in a Free-running, Periodic, or One-shot mode.

### 8.1.3.3 Watchdog

The two watchdog blocks allow the CPU to be interrupted if it has not interacted with the watchdog timer before it expires. In addition, this interrupt will be an output of the core so that it can be used to reset the CPU in the event that a direct interrupt to the CPU is not useful. This will allow the CPU to get back to a known state in the event a program is no longer executing as expected. The watchdog module applies a reset to a system in the event of a software failure, providing a way to recover from software crashes.

### 8.1.3.4 Wake up Timer

This timer is a 32-bit count-down timer that operates on the 32kHz sleep clock. It can be used as a general purpose timer for the ARM or as a wakeup source for the chip. It has the ability to be a one-time programmable timer, as it will generate an interrupt/wake-up on expiration and stop operation. It also has the ability to be programmed in an auto reload fashion where it will generate an interrupt/wake-up and then proceed to start another countdown sequence.

### 8.1.3.5 SPI Controller

See Section 10.3.

### 8.1.3.6 I<sup>2</sup>C Controller

See Section 10.2.

### 8.1.3.7 SPI-Flash Controller

The AHB SPI-Flash Controller is used to access an internal stacked Flash memory to access various instruction/data code needed for storing application code, code patches, and OTA images. Supports several SPI modes including 0, 1, 2, and 3.

### 8.1.3.8 UART

See Section 0.

### 8.1.3.9 DMA Controller

Direct Memory Access (DMA) allows certain hardware subsystems to access main system memory independently of the Cortex-M0 Processor.

The DMA features and benefits are:

- Supports any address alignment
- Supports any buffer size alignment
- Peripheral flow control, including peripheral block transfer
- The following modes are supported:
  - Peripheral to peripheral transfer
  - Memory to memory
  - Memory to peripheral
  - Peripheral to memory
  - Register to memory

- Interrupts for both TX done and RX done in memory and peripheral mode
- Scheduled transfers
- Endianness byte swapping
- Watchdog timer
- Four channel operation
- 32-bit Data width
- AHB MUX (on read and write buses)
- Command lists support
- Usage of tokens

### 8.1.3.10 Nested Vector Interrupt Controller

External interrupt signals connect to the NVIC, and the NVIC prioritizes the interrupts. Software can set the priority of each interrupt. The NVIC and the Cortex-M0 processor core are closely coupled, providing low latency interrupt processing and efficient processing of late arriving interrupts.

All NVIC registers are accessible via word transfers and are little-endian. Any attempt to read or write a half-word or byte individually is unpredictable.

The NVIC allows the CPU to be able to individually enable, disable each interrupt source and hold each interrupt until it has been serviced and cleared by the CPU.

**Table 8-1. NVIC Register Summary**

Name	Description
ISER	Interrupt Set-Enable Register
ICER	Interrupt Clear-Enable Register
ISPR	Interrupt Set-Pending Register
ICPR	Interrupt Clear-Pending Register
IPR0-IPR7	Interrupt Priority Registers

For a description of each register, see the Cortex-M0 documentation from ARM.

### 8.1.3.11 GPIO Controller

The AHB GPIO is a general-purpose I/O interface unit allowing the CPU to independently control all input or output signals on SAMB11. These can be used for a wide variety of functions pertaining to the application.

The AHB GPIO provides a 16-bit I/O interface with the following features:

- Programmable interrupt generation capability
- Programmable masking support
- Thread-safe operation by providing separate set and clear addresses for control registers
- Inputs are sampled using a double flip-flop to avoid meta-stability issues

## 8.2 Memory Subsystem

The Cortex-M0 core uses a 128kB instruction/boot ROM along with a 128kB shared instruction and data RAM.

### 8.2.1 Shared Instruction and Data Memory

The Instruction and Data Memory (IDRAM1 and IDRAM2) contains instructions and data used by the ARM. The size of IDRAM1 and IDRAM2 is 128kB that can be used for BLE subsystem as well as for the user application. IDRAM1 contains the three 32kB and IDRAM2 contains two 16kB memories that are accessible to the ARM and used for instruction/data storage.

## 8.2.2 ROM

The ROM is used to store the boot code and BLE firmware, stack, and selected user profiles. ROM contains the 128kB memory that is accessible to the ARM.

## 8.2.3 BLE Retention Memory

The BLE functionality requires 8kB (or more depending on the application) state, instruction and data to be retained in memory when the processor either goes into Sleep Mode or Power Off Mode. The RAM is separated into specific power domains to allow tradeoff in power consumption with retention memory size.

## 8.3 Non-volatile Memory

SAMB11 has 768 bits of non-volatile eFuse memory that can be read by the CPU after device reset. This non-volatile one-time-programmable memory can be used to store customer-specific parameters, such as BLE address, XO calibration information, TX power, crystal frequency offset, etc., as well as other software-specific configuration parameters. The eFuse is partitioned into six 128-bit banks. The bitmap of the first bank is shown in Figure 8-2. The purpose of the first 80 bits in bank 0 is fixed, and the remaining bits are general-purpose software dependent bits or are reserved for future use. Since each bank and each bit can be programmed independently, this allows for several updates of the device parameters following the initial programming, e.g. updating BLE address (this can be done by invalidating the last programmed bank and programming a new bank). Refer to SAMB11 Programming Guide for the eFuse programming instructions.

Figure 8-2. SAMB11 eFuse Bit Map

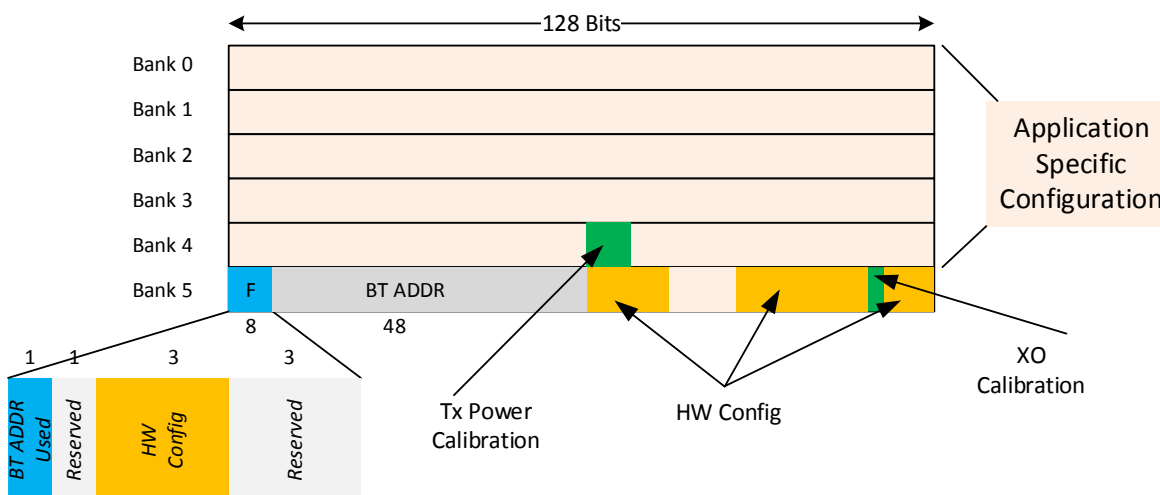

## 8.4 Flash Memory

SAMB11 has 256kB of Flash memory, stacked on top of the MCU+BLE System on Chip. It is accessed through the SPI Flash controller and uses the 26MHz clock.

Flash memory features are:

- 256-bytes per programmable page
- Uniform 4kB Sectors, 32kB & 64kB Blocks
- Sector Erase (4K-byte)
- Block Erase (32K or 64K-byte)
- Page program up to 256 bytes <1ms
- More than 100,000 erase/write cycles and more than 20-year data retention
- 2.3V to 3.6V supply range
- 1mA active current, <1µA Power-down

## 9 Bluetooth Low Energy (BLE) Subsystem

The BLE subsystem implements all the critical real-time functions required for full compliance with Specification of the Bluetooth System, v4.1, Bluetooth SIG.

It consists of a Bluetooth 4.1 baseband controller (core), radio transceiver and the Atmel Bluetooth Smart Stack, the BLE Software Platform.

### 9.1 BLE Core

The baseband controller consists of a modem and Medium Access Controller (MAC) and it encodes and decodes HCI packets, constructs baseband data packages, schedules frames, manages and monitors connection status, slot usage, data flow, routing, segmentation, and buffer control.

The core performs Link Control Layer management supporting the main BLE states, including advertising and connection.

#### 9.1.1 Features

- Broadcaster, Central, Observer, and Peripheral
- Simultaneous Master and Slave operation, connect up to eight slaves
- Frequency Hopping
- Advertising/Data/Control packet types
- Encryption (AES-128, SHA-256)
- Bitstream processing (CRC, whitening)
- Operating clock 52MHz

### 9.2 BLE Radio

The radio consists of a fully integrated transceiver, including Low Noise Amplifier, Receive (RX) down converter, and analog baseband processing as well as Phase Locked Loop (PLL), Transmit (TX) Power Amplifier, and Transmit/Receive switch. At the RF front end, no external RF components on the PCB are required other than the antenna and a matching component.

The RX sensitivity and TX output power of the radio together with the 4.1 PHY core provide a 100dB RF link budget for superior range and link reliability.

#### 9.2.1 Receiver Performance

Table 9-1. SAMB11 BLE Receiver Performance

Parameter	Minimum	Typical	Maximum	Unit
Frequency	2,402		2,480	MHz
Sensitivity with on-chip DC/DC	-94.5	-93		dBm
Maximum receive signal level		+5		
CCI		12.5		dB
ACI (N±1)		0		
N+2 Blocker (Image)		-20		
N-2 Blocker		-38		
N+3 Blocker (Adj. Image) <sup>5</sup>		-35		
N-3 Blocker		-43		

Parameter	Minimum	Typical	Maximum	Unit
N±4 or greater		-45		dB
Intermod (N+3, N+6)		-32		dBm
OOB (2GHz<f<2.399GHz)	-15			
OOB (f<2GHz)	-10			
RX peak current draw		4.0 <sup>(1)</sup>		mA

Note: 1. At -93dBm sensitivity setting. Add 0.2mA at 3.3V for best sensitivity setting.

All measurements performed at 3.6V VBATT and 25°C, with tests following Bluetooth V4.1 standard tests.

There are two gain settings for Sensitivity, high gain (-95dBm) and low gain (-93dBm). Low gain has lower current consumption.

### 9.2.2 Transmitter Performance

The transmitter has fine step power control with P<sub>out</sub> variable in <3dB steps below 0dBm and in <0.5dB steps above 0dBm.

**Table 9-2. SAMB11 BLE Transmitter Performance**

Parameter	Minimum	Typical	Maximum	Unit
Frequency	2,402		2,480	MHz
Output power range	-20	0	3.5	dBm
Maximum output power		3.5		
In-band Spurious (N±2)		-45		
In-band Spurious (N±3)		-50		
2 <sup>nd</sup> harmonic P <sub>out</sub>	-41			
3 <sup>rd</sup> harmonic P <sub>out</sub>	-41			
4 <sup>th</sup> harmonic P <sub>out</sub>	-41			
5 <sup>th</sup> harmonic P <sub>out</sub>	-41			
Frequency deviation		±250		kHz
TX peak current draw		3.0 <sup>(1)</sup>		mA

Note: 1. At 0dBm TX output power.

All measurements performed at 3.6V VBATT and 25°C, with tests following Bluetooth V4.1 standard tests.



### 9.3 Atmel Bluetooth SmartConnect Stack

The SAMB11 has a completely integrated Bluetooth Low Energy stack on chip, fully qualified, mature, and Bluetooth V4.1 compliant.

Customer applications interface with the BLE protocol stack through the Atmel BLE API, which supports direct access to the GAP, SMP, ATT, GATT client / server, and L2CAP service layer protocols in the embedded firmware.

The stack includes numerous BLE profiles for applications like:

- Smart Energy
- Consumer Wellness
- Home Automation
- Security
- Proximity Detection
- Entertainment
- Sports and Fitness
- Automotive

Together with the Atmel Studio Software Development environment, additional customer profiles can be easily developed.

The Atmel Bluetooth SmartConnect software development kit is based on Keil and IAR™ compiler tools and contains numerous application code examples for embedded and hosted modes.

In addition to the protocol stack, drivers for each peripheral hardware block are provided.

## 10 External Interfaces

### 10.1 Overview

SAMB11 external interfaces include: 2xSPI Master/Slave (SPI0 and SPI1), 2xI<sup>2</sup>C Master/Slave (I<sup>2</sup>C0 and I<sup>2</sup>C1), 2xI<sup>2</sup>C Slave-only (I<sup>2</sup>C2), 2xUART (UART1 and UART2), 1xSWD, and General Purpose Input/Output (GPIO) pins. For specific programming instructions, refer to SAMB11 Programming Guide.

Table 10-1 illustrates the different peripheral functions that are software selectable for each pin. This allows for maximum flexibility of mapping desired interfaces on GPIO pins. The MUX1 option allows for any MEGAMUX option from Table 10-2 to be assigned to a GPIO.

**Table 10-1. SAMB11 Pin-MUX Matrix of External Interfaces**

Pin Name	Pin #	Pull	MUX0	MUX1	MUX2	MUX3	MUX4	MUX5	MUX6	MUX7
LP_GPIO_0	5	Up/Down	GPIO 0	MEGAMUX 0	SWD CLK					TEST OUT 0
LP_GPIO_1	6	Up/Down	GPIO 1	MEGAMUX 1	SWD IO					TEST OUT 1
LP_GPIO_2	7	Up/Down	GPIO 2	MEGAMUX 2	UART1 RXD		SPI1 SCK	SPI0 SCK		TEST OUT 2
LP_GPIO_3	8	Up/Down	GPIO 3	MEGAMUX 3	UART1 TXD		SPI1 MOSI	SPI0 MOSI		TEST OUT 3
LP_GPIO_4	9	Up/Down	GPIO 4	MEGAMUX 4	UART1 CTS		SPI1 SSN	SPI0 SSN		TEST OUT 4
LP_GPIO_5	12	Up/Down	GPIO 5	MEGAMUX 5	UART1 RTS		SPI1 MISO	SPI0 MISO		TEST OUT 5
LP_GPIO_6	13	Up/Down	GPIO 6	MEGAMUX 6	UART2 RXD			SPI0 SCK		TEST OUT 6
LP_GPIO_7	14	Up/Down	GPIO 7	MEGAMUX 7	UART2 TXD			SPI0 MOSI		TEST OUT 7
LP_GPIO_8	15	Up/Down	GPIO 8	MEGAMUX 8	I <sup>2</sup> C0 SDA	I <sup>2</sup> C2 SDA		SPI0 SSN		TEST OUT 8
LP_GPIO_9	16	Up/Down	GPIO 9	MEGAMUX 9	I <sup>2</sup> C0 SCL	I <sup>2</sup> C2 SCL		SPI0 MISO		TEST OUT 9
LP_GPIO_10	17	Up/Down	GPIO 10	MEGAMUX 10	SPI0 SCK					TEST OUT 10
LP_GPIO_11	18	Up/Down	GPIO 11	MEGAMUX 11	SPI0 MOSI					TEST OUT 11
LP_GPIO_12	19	Up/Down	GPIO 12	MEGAMUX 12	SPI0 SSN					TEST OUT 12
LP_GPIO_13	20	Up/Down	GPIO 13	MEGAMUX 13	SPI0 MISO					TEST OUT 13
LP_GPIO_14	36	Up/Down	GPIO 14	MEGAMUX 14	UART2 CTS		I <sup>2</sup> C1 SDA			TEST OUT 14
LP_GPIO_15	37	Up/Down	GPIO 15	MEGAMUX 15	UART2 RTS		I <sup>2</sup> C1 SCL			TEST OUT 15
LP_GPIO_16	38	Up/Down	GPIO 16	MEGAMUX 16			SPI1 SSN	SPI0 SCK		TEST OUT 16
LP_GPIO_17	40	Up/Down	GPIO 17	MEGAMUX 17		I <sup>2</sup> C2 SDA	SPI1 SCK	SPI0 MOSI		TEST OUT 17
LP_GPIO_18	41	Up/Down	GPIO 18	MEGAMUX 18		I <sup>2</sup> C2 SCL	SPI1 MISO	SPI0 SSN		TEST OUT 18
LP_GPIO_19	42	Up/Down	GPIO 19	MEGAMUX 19			SPI1 MOSI	SPI0 MISO		TEST OUT 19
LP_GPIO_20	43	Up/Down	GPIO 20	MEGAMUX 20						TEST OUT 20
LP_GPIO_22	10	Up/Down	GPIO 22	MEGAMUX 22						
LP_GPIO_23	11	Up/Down	GPIO 23	MEGAMUX 23						
AO_GPIO_0	33	Up	GPIO 31	WAKEUP	RTC CLK IN	32KHZ CLKOUT				
AO_GPIO_1	34	Up	GPIO 30	WAKEUP	RTC CLK IN	32KHZ CLKOUT				
AO_GPIO_2	35	Up	GPIO 29	WAKEUP	RTC CLK IN	32KHZ CLKOUT				

Pin Name	Pin #	Pull	MUX0	MUX1	MUX2	MUX3	MUX4	MUX5	MUX6	MUX7
GPIO_MS1	24	Up/Down	GPIO 47							
GPIO_MS2	25	Up/Down	GPIO 46							
GPIO_MS3	27	Up/Down	GPIO 45							
GPIO_MS4	28	Up/Down	GPIO 44							

Table 10-2 shows the various software selectable MEGAMUX options that correspond to specific peripheral functionality. Several MEGAMUX options provide an interface to manage Wi-Fi BLE coexistence issues.

**Table 10-2. SAMB11 Software Selectable MEGAMUX Options**

MUX_Sel	Function	Notes
0	UART1 RXD	
1	UART1 TXD	
2	UART1 CTS	
3	UART1 RTS	
4	UART2 RXD	
5	UART2 TXD	
6	UART2 CTS	
7	UART2 RTS	
8	I2C0 SDA	
9	I2C0 SCL	
10	I2C1 SDA	
11	I2C1 SCL	
12	PWM 1	
13	PWM 2	
14	PWM 3	
15	PWM 4	
16	LP CLOCK OUT	32kHz clock output (RC Osc or RTC XO)
17	WLAN TX ACTIVE	Coexistence: Wi-Fi is currently transmitting
18	WLAN RX ACTIVE	Coexistence: Wi-Fi is currently receiving
19	BLE TX ACTIVE	Coexistence: BLE is currently transmitting
20	BLE RX ACTIVE	Coexistence: BLE is currently receiving
21	BLE IN PROCESS	Coexistence Signal
22	BLE MBSY	Coexistence Signal
23	BLE SYNC	Coexistence Signal
24	BLE RXNTX	Coexistence Signal
25	BLE PTI 0	Coexistence: BLE Priority
26	BLE PTI 1	Coexistence: BLE Priority

MUX_Sel	Function	Notes
27	BLE PTI 2	Coexistence: BLE Priority
28	BLE PTI 3	Coexistence: BLE Priority
29	QUAD DEC X IN A	
30	QUAD DEC X IN B	
31	QUAD DEC Y IN A	
32	QUAD DEC Y IN B	
33	QUAD DEC Z IN A	
34	QUAD DEC Z IN B	

An example of peripheral assignment using these MEGAMUX options is as follows:

- I<sup>2</sup>C0 pin-muxed on LP\_GPIO\_10 and LP\_GPIO\_11 via MUX1 and MEGAMUX=8 and 9
- I<sup>2</sup>C1 pin-muxed on LP\_GPIO\_0 and LP\_GPIO\_1 via MUX1 and MEGAMUX=10 and 11
- PWM pin-muxed on LP\_GPIO\_16 via MUX1 and MEGAMUX=12

Another example is to illustrate the available options for pin LP\_GPIO\_3, depending on the pin-MUX option selected:

- MUX0: the pin will function as bit 3 of the GPIO bus and is controlled by the GPIO controller in the ARM subsystem
- MUX1: any option from the MEGAMUX table can be selected, for example, it can be a quad\_dec, pwm, or any of the other functions listed in the MEGAMUX table
- MUX2: the pin will function as UART1 TXD; this can be also achieved with the MUX1 option via MEGAMUX, but the MUX2 option allows a shortcut for the recommended pinout
- MUX3: this option is not used and thus defaults to the GPIO option (same as MUX0)
- MUX4: the pin will function as SPI1 MOSI (this option is not available through MEGAMUX)
- MUX5: the pin will function as SPI0 MOSI (this option is not available through MEGAMUX)
- MUX6: the pin will function as SPI FLASH SCK (this option is not available through MEGAMUX)
- MUX7: the pin will function as bit 3 of the test output bus, giving access to various debug signals

## 10.2 I<sup>2</sup>C Master/Slave Interface

### 10.2.1 Description

The SAMB11 provides I<sup>2</sup>C Interface that can be configured as Slave or Master. The I<sup>2</sup>C Interface is a two-wire serial interface consisting of a serial data line (SDA) and a serial clock line (SCL). The SAMB11 I<sup>2</sup>C supports I<sup>2</sup>C bus Version 2.1 - 2000 and can operate in the following speed modes:

- Standard mode (100kb/s)
- Fast mode (400kb/s)
- High-speed mode (3.4Mb/s)

The I<sup>2</sup>C is a synchronous serial interface. The SDA line is a bidirectional signal and changes only while the SCL line is low, except for STOP, START, and RESTART conditions. The output drivers are open-drain to perform wire-AND functions on the bus. The maximum number of devices on the bus is limited by only the maximum capacitance specification of 400pF. Data is transmitted in byte packages.

For specific information, refer to the Philips Specification entitled "The I<sup>2</sup>C -Bus Specification, Ver2.1".

## 10.2.2 I<sup>2</sup>C Interface Timing

The I<sup>2</sup>C Interface timing (common to Slave and Master) is provided in Figure 10-1. The timing parameters for Slave and Master modes are specified in Table 10-3 and Table 10-4 respectively.

Figure 10-1. SAMB11 I<sup>2</sup>C Slave Timing Diagram

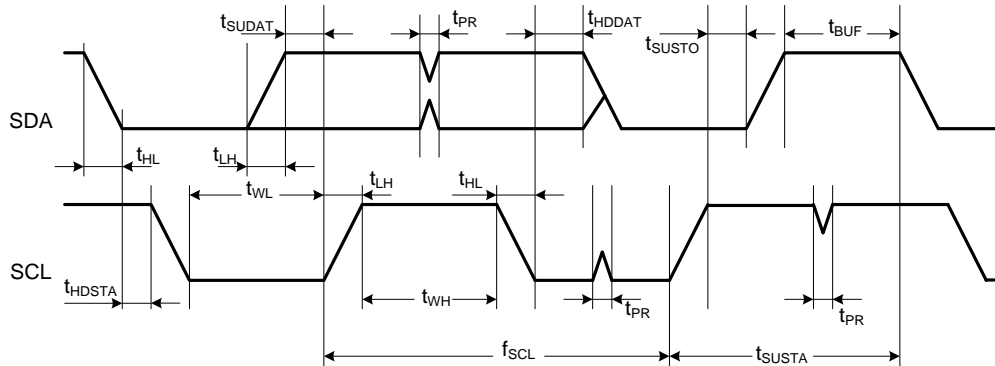

Table 10-3. SAMB11 I<sup>2</sup>C Slave Timing Parameters

Parameter	Symbol	Min.	Max.	Units	Remarks
SCL Clock Frequency	$f_{SCL}$	0	400	kHz	
SCL Low Pulse Width	$t_{WL}$	1.3		$\mu$ s	
SCL High Pulse Width	$t_{WH}$	0.6			
SCL, SDA Fall Time	$t_{HL}$		300	ns	This is dictated by external components
SCL, SDA Rise Time	$t_{LH}$		300		
START Setup Time	$t_{SUSTA}$	0.6		$\mu$ s	
START Hold Time	$t_{HDSTA}$	0.6			
SDA Setup Time	$t_{SUDAT}$	100		ns	Slave and Master Default Master Programming Option
SDA Hold Time	$t_{HDDAT}$	0 40			
STOP Setup time	$t_{SUSTO}$	0.6		$\mu$ s	
Bus Free Time Between STOP and START	$t_{BUF}$	1.3			
Glitch Pulse Reject	$t_{PR}$	0	50	ns	

Table 10-4. SAMB11 I<sup>2</sup>C Master Timing Parameters

Parameter	Symbol	Standard mode		Fast mode		High-speed mode		Units
		Min.	Max.	Min.	Max.	Min.	Max.	
SCL Clock Frequency	$f_{SCL}$	0	100	0	400	0	3400	kHz
SCL Low Pulse Width	$t_{WL}$	4.7		1.3		0.16		$\mu$ s
SCL High Pulse Width	$t_{WH}$	4		0.6		0.06		
SCL Fall Time	$t_{HL}$		300		300	10	40	ns

Parameter	Symbol	Standard mode		Fast mode		High-speed mode		Units
		Min.	Max.	Min.	Max.	Min.	Max.	
SDA Fall Time	t <sub>HLSDA</sub>		300		300	10	80	
SCL Rise Time	t <sub>LHSCCL</sub>		1000		300	10	40	
SDA Rise Time	t <sub>LHSDA</sub>		1000		300	10	80	
START Setup Time	t <sub>SUSTA</sub>	4.7		0.6		0.16		μs
START Hold Time	t <sub>HDSTA</sub>	4		0.6		0.16		
SDA Setup Time	t <sub>SUDAT</sub>	250		100		10		ns
SDA Hold Time	t <sub>HDDAT</sub>	5		40		0	70	
STOP Setup time	t <sub>SUSTO</sub>	4		0.6		0.16		μs
Bus Free Time Between STOP and START	t <sub>BUF</sub>	4.7		1.3				
Glitch Pulse Reject	t <sub>PR</sub>			0	50			ns

## 10.3 SPI Master/Slave Interface

### 10.3.1 Description

SAMB11 provides a Serial Peripheral Interface (SPI) that can be configured as Master or Slave. The SPI Interface pins are mapped as shown in [Table 10-5](#). The SPI Interface is a full-duplex slave-synchronous serial interface. When the SPI is not selected, i.e., when SSN is high, the SPI interface will not interfere with data transfers between the serial-master and other serial-slave devices. When the serial slave is not selected, its transmitted data output is buffered, resulting in a high impedance drive onto the serial master receive line. The SPI Slave interface responds to a protocol that allows an external host to read or write any register in the chip as well as initiate DMA transfers. For the details of the SPI protocol and more specific instructions, refer to SAMB11 Programming Guide.

**Table 10-5. SAMB11 SPI Interface Pin Mapping**

Pin Name	SPI Function
SSN	Active Low Slave Select
SCK	Serial Clock
MOSI	Master Out Slave In (Data)
MISO	Master In Slave Out (Data)

### 10.3.2 SPI Interface Modes

The SPI Interface supports four standard modes as determined by the Clock Polarity (CPOL) and Clock Phase (CPHA) settings. These modes are illustrated in Table 10-6 and Figure 10-2. The red lines in Figure 10-2 correspond to Clock Phase = 0 and the blue lines correspond to Clock Phase = 1.

Table 10-6. SAMB11 SPI Modes

Mode	CPOL	CPHA
0	0	0
1	0	1
2	1	0
3	1	1

Figure 10-2. SAMB11 SPI Clock Polarity and Clock Phase Timing

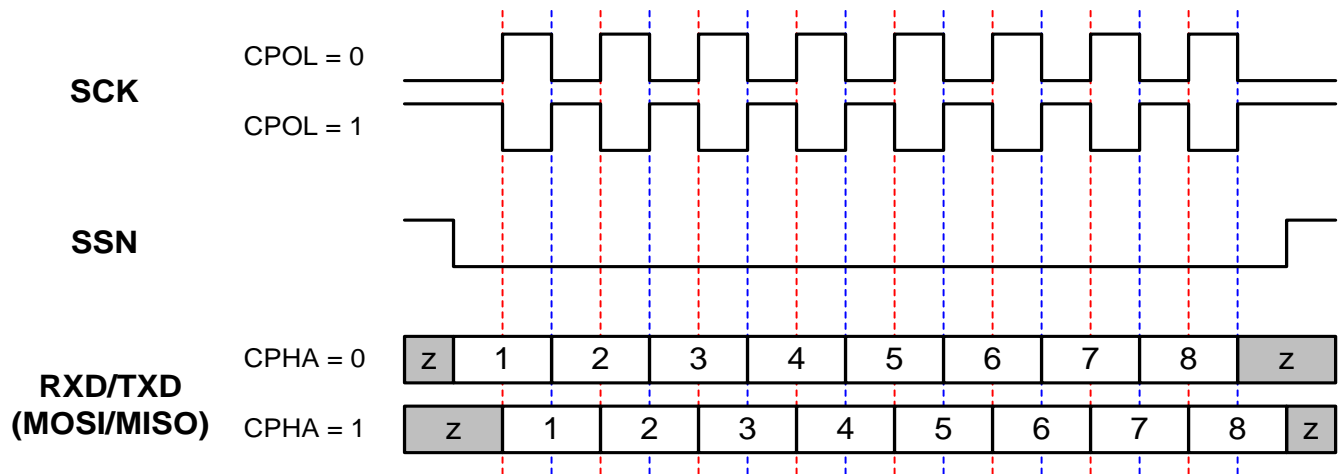

### 10.3.3 SPI Slave Timing

The SPI Slave timing is provided in [Figure 10-3](#) and [Table 10-7](#).

**Figure 10-3. SAMB11 SPI Slave Timing Diagram**

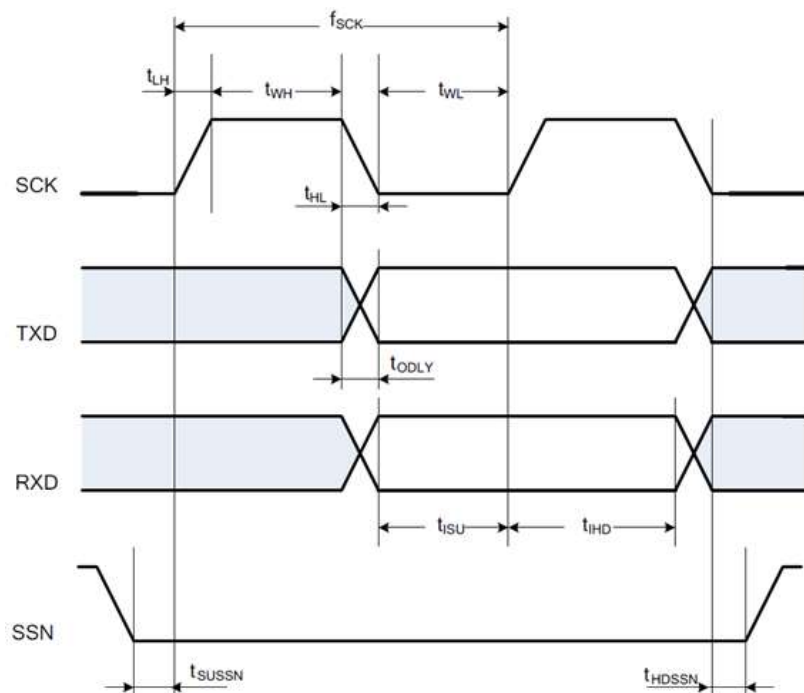

**Table 10-7. ATBTLC1000 SPI Slave Timing Parameters<sup>(1)</sup>**

Parameter	Symbol	Min.	Max.	Units
Clock Input Frequency <sup>(2)</sup>	$f_{SCK}$		2	MHz
Clock Low Pulse Width	$t_{WL}$	55		ns
Clock High Pulse Width	$t_{WH}$	55		
Clock Rise Time	$t_{LH}$	0	7	
Clock Fall Time	$t_{HL}$	0	7	
TXD Output Delay <sup>(3)</sup>	$t_{ODLY}$	7	28	
RXD Input Setup Time	$t_{ISU}$	5		
RXD Input Hold Time	$t_{IHD}$	10		
SSN Input Setup Time	$t_{SUSSN}$	5		
SSN Input Hold Time	$t_{HDSSN}$	10		

- Notes:
1. Timing is applicable to all SPI modes
  2. Maximum clock frequency specified is limited by the SPI Slave interface internal design, actual maximum clock frequency can be lower and depends on the specific PCB layout
  3. Timing based on 15pF output loading



### 10.3.4 SPI Master Timing

The SPI Master Timing is provided in 0 and Table 10-8.

Figure 10-4. SAMB11 SPI Master Timing Diagram

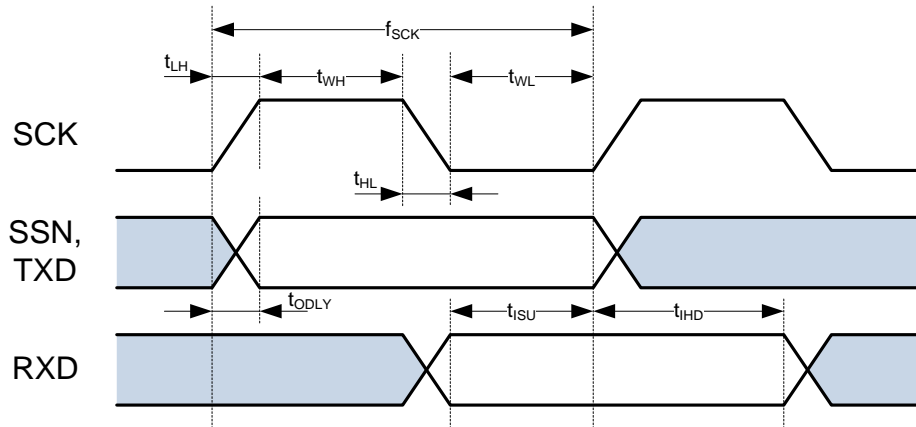

Table 10-8. ATBTLC1000 SPI Master Timing Parameters <sup>(1)</sup>

Parameter	Symbol	Min.	Max.	Units
Clock Output Frequency <sup>(2)</sup>	$f_{SCK}$		4	MHz
Clock Low Pulse Width	$t_{WL}$	30		ns
Clock High Pulse Width	$t_{WH}$	32		
Clock Rise Time <sup>(3)</sup>	$t_{LH}$		7	
Clock Fall Time <sup>(3)</sup>	$t_{HL}$		7	
RXD Input Setup Time	$t_{ISU}$	23		
RXD Input Hold Time	$t_{IHD}$	0		
SSN/TXD Output Delay <sup>(3)</sup>	$t_{ODLY}$	0	12	

- Notes:
1. Timing is applicable to all SPI modes
  2. Maximum clock frequency specified is limited by the SPI Master interface internal design, actual maximum clock frequency can be lower and depends on the specific PCB layout
  3. Timing based on 15pF output loading

## 10.4 UART Interface

SAMB11 provides Universal Asynchronous Receiver/Transmitter (UART) interfaces for serial communication. The Bluetooth subsystem has two UART interfaces: a 4-pin interface for control and data transfer. The UART interfaces are compatible with the RS-232 standard, where SAMB11 operates as Data Terminal Equipment (DTE). The 2-pin UART has receive and transmit pins (RXD and TXD), and the 4-pin UART has two additional pins used for flow control/handshaking: Request To Send (RTS) and Clear To Send (CTS).

### IMPORTANT

**The RTS and CTS are used for hardware flow control; they MUST be connected to the host MCU UART and enabled for the UART interface to be functional.**

The pins associated with each UART interfaces can be enabled on several alternative pins by programming their corresponding pin-MUX control registers (see [Table 10-1](#) and [Table 10-2](#) for available options).

The UART features programmable baud rate generation with fractional clock division, which allows transmission and reception of a wide variety of standard and non-standard baud rates. The Bluetooth UART input clock is selectable between 26MHz, 13MHz, 6.5MHz, and 3.25MHz. The clock divider value is programmable as 13 integer bits and three fractional bits (with 8.0 being the smallest recommended value for normal operation). This results in the maximum supported baud rate of  $26\text{MHz}/8.0 = 3.25\text{MBd}$ .

The UART can be configured for seven or eight bit operation, with or without parity, with four different parity types (odd, even, mark, or space), and with one or two stop bits. It also has RX and TX FIFOs, which ensure reliable high speed reception and low software overhead transmission. FIFO size is 4 x 8 for both RX and TX direction. The UART also has status registers showing the number of received characters available in the FIFO and various error conditions, as well the ability to generate interrupts based on these status bits.

An example of UART receiving or transmitting a single packet is shown in [Figure 10-5](#). This example shows 7-bit data (0x45), odd parity, and two stop bits.

For more specific instructions, refer to SAMB11 Programming Guide.

**Figure 10-5. Example of UART RX or TX packet**

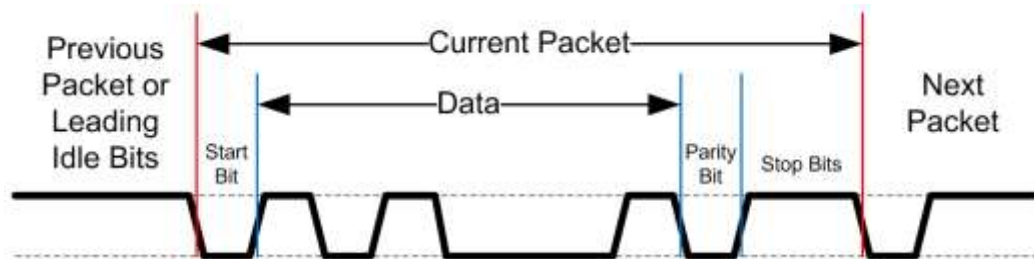

## 10.5 GPIOs

Thirty General Purpose Input/Output (GPIO) pins total, labeled LP\_GPIO, GPIO\_MS, and AO\_GPIO, are available to allow for application specific functions. Each GPIO pin can be programmed as an input (the value of the pin can be read by the host or internal processor) or as an output. The host or internal processor can program output values.

LP\_GPIO are digital interface pins, GPIO\_MS are mixed signal/analog interface pins and AO\_GPIO is an always-on digital interface pin that can detect interrupt signals while in deep sleep mode for wake-up purposes.

The LP\_GPIO have interrupt capability, but only when in active/standby mode. In sleep mode, they are turned off to save power consumption.



## 10.6 Analog to Digital Converter (ADC)

### 10.6.1 Overview

The SAMB11 has an integrated Successive Approximation (SAR) ADC with 11-bit resolution and variable conversion speed up to 1MS/s. The key building blocks are the capacitive DAC, comparator, and synchronous SAR engine as shown in Figure 10-6.

Figure 10-6. SAMB11 SAR ADC Block Diagram

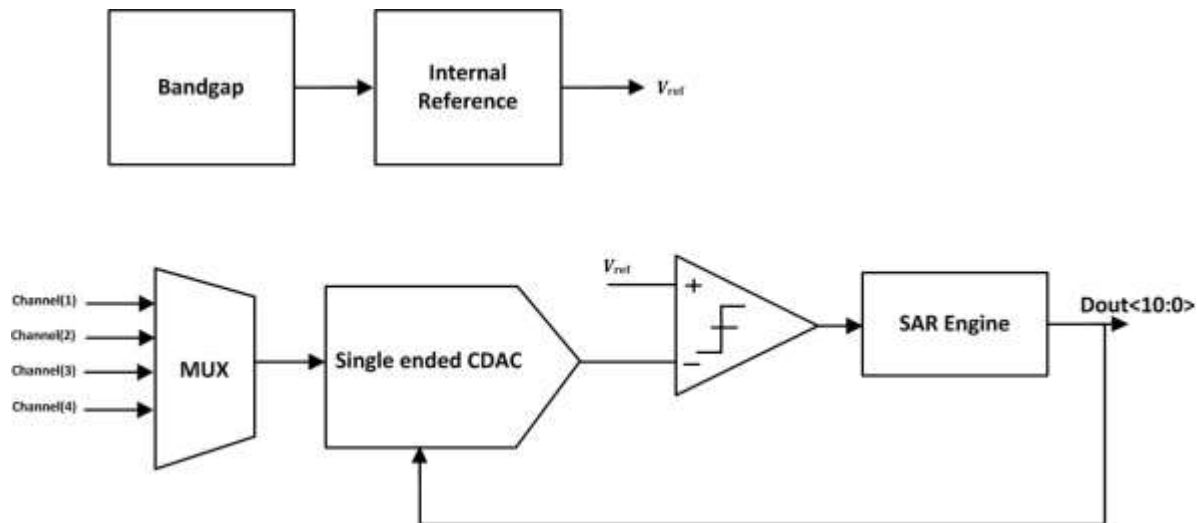

The ADC reference voltage can be either generated internally or set externally via one of the four available Mixed Signal GPIO pins on the SAMB11.

There are two modes of operation:

- A. High resolution (11-bit): Set the reference voltage to half the supply voltage or below. In this condition the input signal, dynamic range is equal to twice the reference voltage (ENOB=10bit).
- B. Medium Resolution (10-bit): Set the reference voltage to any value below supply voltage (up to supply voltage - 300mV) and in this condition the input dynamic range is from zero to the reference voltage (ENOB = 9bit).

There are four input channels that are time multiplexed to the input of the SAR ADC.

In power saving mode, the internal reference voltage is completely off and the reference voltage is set externally.

The ADC characteristics are summarized in Table 10-9.

Table 10-9. SAR ADC Characteristics

Conversion rate	1ks → 1MS
Selectable Resolution	10 → 11bit
Power consumption	13.5µA (at 100KS/s) <sup>(1)</sup>

Note: 1. With external reference.

### 10.6.2 Timing

The ADC timing is shown in Figure 10-7. The input signal is sampled twice, in the first sampling cycle the input range is defined either to be above reference voltage or below it and in the second sampling instant the ADC starts its normal operation.

The ADC takes two sampling instants and N-1 conversion cycle (N=ADC resolution) and one cycle to sample the data out. Therefore, for the 11-bit resolution, it takes 13 clock cycles to do one Sample conversion.

The Input clock equals N+2 the sampling clock frequency (N is the ADC resolution).

CONV signal : Gives indication about the end of conversion.

SAMPL : The input signal is sampled when this signal is high.

RST ENG : When High SAR Engine is in reset mode (SAR engine output is set to mid-scale).

**Figure 10-7. SAR ADC Timing**

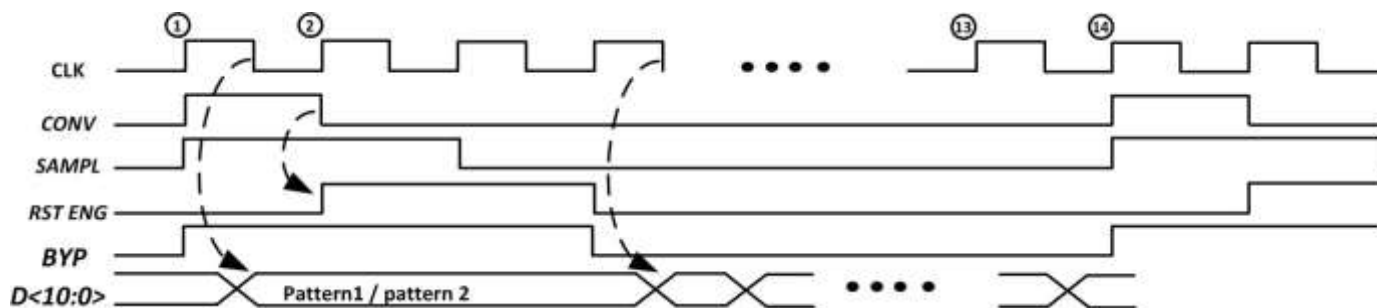

### 10.6.3 Performance

**Table 10-10. Static Performance of SAR ADC**

Parameter	Condition	Min.	Typ.	Max.	Unit
Input voltage range		0		VBAT	V
Resolution			11		bits
Sample rate			100	1000	KSPS
Input offset	Internal VREF	-10		+10	mV
Gain error	Internal VREF	-4		+4	%
DNL	100KSPS. Internal VREF=1.6V. Same result for external VREF.	-0.75		+1.75	LSB
INL	100KSPS. Internal VREF=1.6V. Same result for external VREF.	-2		+2.5	
THD	1kHz sine input at 100KSPS		73		dB
SINAD	1kHz sine input at 100KSPS		62.5		
SFDR	1kHz sine input at 100KSPS		73.7		
Conversion time			13		cycles
Current consumption	Using external VREF, at 100KSPS		13.5		$\mu$ A
	Using internal VREF, at 100KSPS		25.0		
	Using external VREF, at 1MSPS		94		
	Using internal VREF, at 1MSPS		150		
	Using internal VREF, during VBATT monitoring		100		
	Using internal VREF, during temperature monitoring		50		

Parameter	Condition	Min.	Typ.	Max.	Unit
Internal reference voltage	Mean value using VBAT=2.5V		1.026 <sup>(1)</sup>		V
	Standard deviation across parts		10.5		
VBATT sensor accuracy	Without calibration	-55		+55	mV
	With offset and gain calibration	-17		+17	
Temperature sensor accuracy	Without calibration	-9		+9	°C
	With offset calibration	-4		+4	

Note: 1. Effective VREF is 2xInternal Reference Voltage.

$T_c = 25^{\circ}C$   $V_{BAT} = 3.0V$ , unless otherwise noted

Figure 10-8. INL of SAR ADC

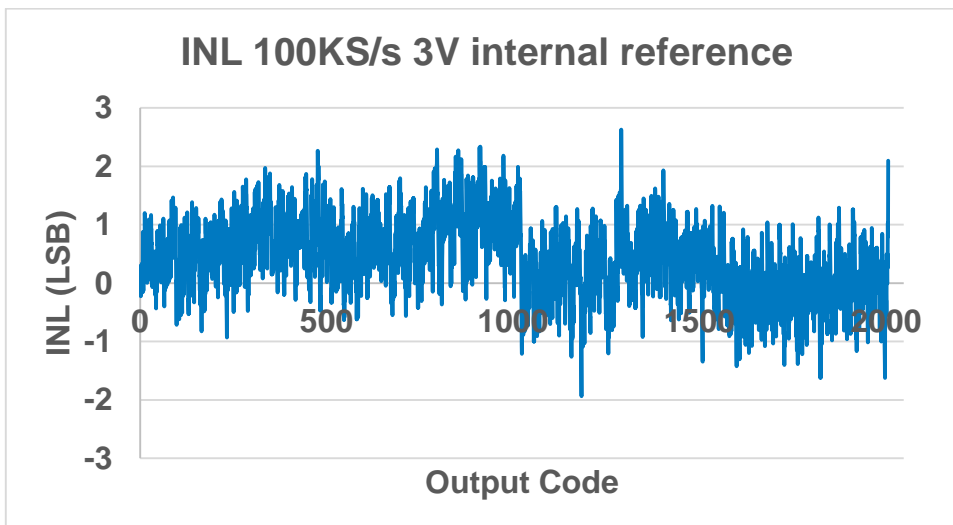
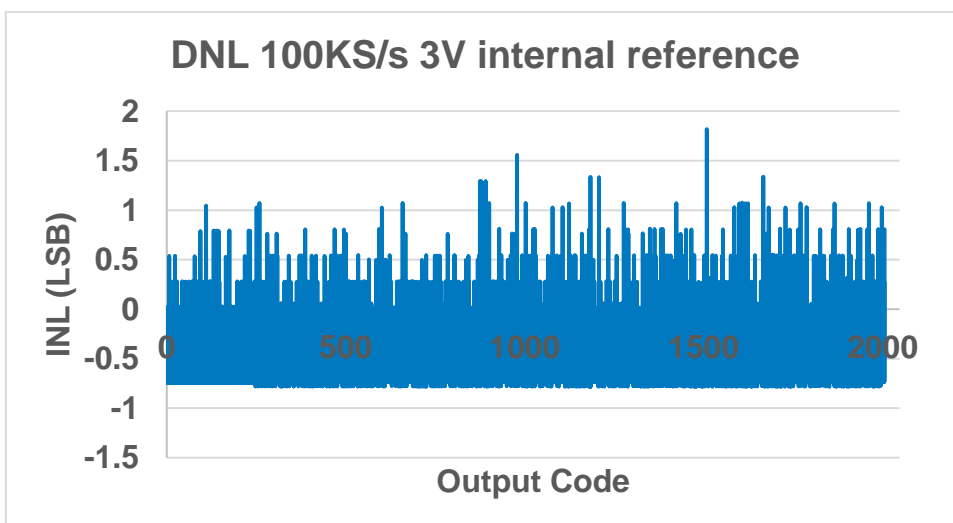
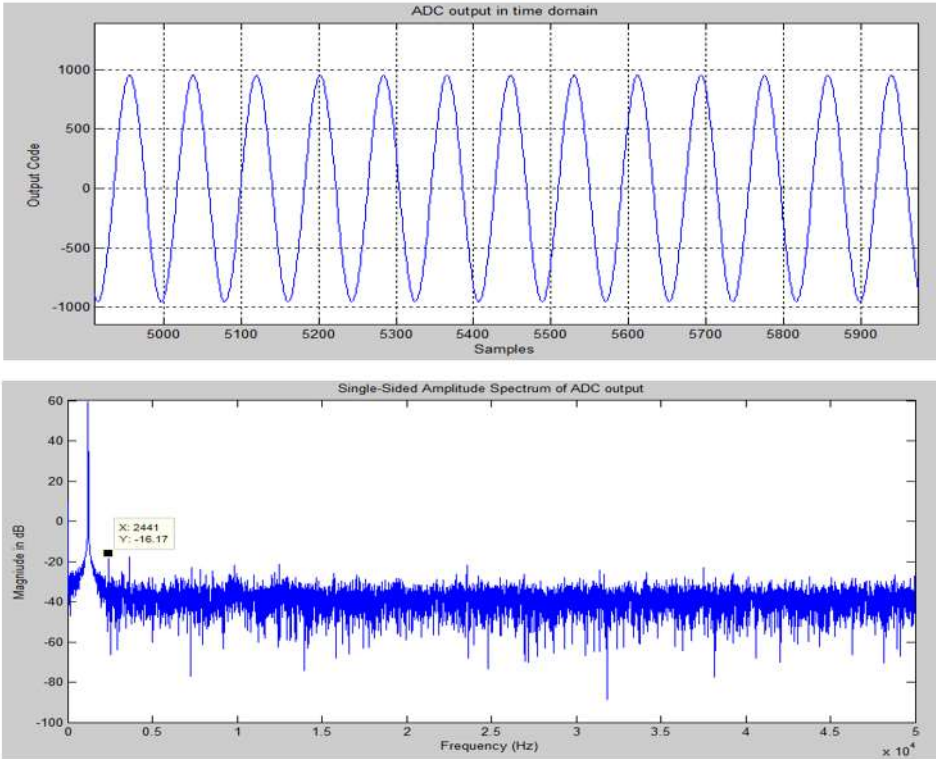

Figure 10-9. DNL of SAR ADC

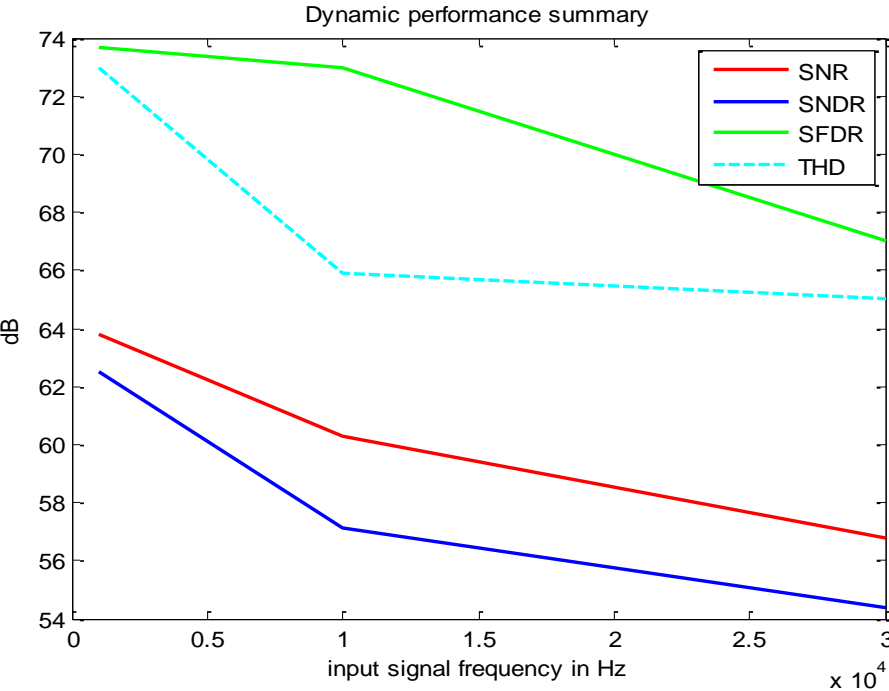

**Figure 10-10. Sensor ADC Dynamic Measurement with Sinusoidal Input**



- Notes:
1. 25°C, 3.6V VBAT, and 100kS/s  
Input Signal: 1kHz sine wave, 3Vp-p amplitude
  2. SNDR = 62.6dB  
SFDR = 73.7dB  
THD = 73.0db

**Figure 10-11. Sensor ADC Dynamic Performance Summary at 100KSPS**



## 10.7 Software Programmable Timer and Pulse Width Modulator

SAMB11 contains four individually configurable pulse width modulator (PWM) blocks to provide external control voltages. The base frequency of the PWM block ( $f_{PWM\_base}$ ) is derived from the XO clock (26MHz) or the RC oscillator followed by a programmable divider.

The frequency of each PWM pulse ( $f_{PWM}$ ) is programmable in steps according to the following relationship:

$$f_{PWM} = \frac{f_{PWM\_base}}{64 * 2^i} \quad i = 0,1,2, \dots, 8$$

The duty cycle of each PWM signal is configurable with 10-bit resolution (minimum duty cycle is 1/1024 and the maximum is 1023/1024).

$f_{PWM\_base}$  can be selected to have different values according to the following table. Minimum and maximum frequencies supported for each clock selection are listed in the table as well.

**Table 10-11.  $f_{PWM}$  Range for Different  $f_{PWM}$  Base Frequencies**

$f_{PWM\_base}$	$f_{PWM}$ max.	$f_{PWM}$ min.
26MHz	406.25kHz	1.586 kHz
13MHz	203.125kHz	793.25 Hz
6.5MHz	101.562kHz	396.72 Hz
3.25MHz	50.781kHz	198.36 Hz

## 10.8 Clock Output

SAMB11 has an ability to output a clock. The clock can be output to any GPIO pin via the test MUX. Note that this feature requires that the ARM and BLE power domains stay on. If BLE is not used, the clocks to the BLE core are gated off, resulting in small leakage. The following two methods can be used to output a clock.

### 10.8.1 Variable Frequency Clock Output Using Fractional Divider

SAMB11 can output the variable frequency ADC clock using a fractional divider of the 26MHz oscillator. This clock needs to be enabled using bit 10 of the `lpmcu_clock_enables_1` register. The clock frequency can be controlled by the divider ratio using the `sens_adc_clk_ctrl` register (12-bits integer part, 8-bit fractional part). The division ratio can vary from 2 to 4096 delivering output frequency between 6.35kHz to 13MHz. This is a digital divider with pulse swallowing implementation so the clock edges may not be at exact intervals for the fractional ratios. However, it is exact for integer division ratios.

### 10.8.2 Fixed Frequency Clock Output

SAMB11 can output the following fixed-frequency clocks:

- 52MHz derived from XO
- 26MHz derived from XO
- 2MHz derived from the 2MHz RC Osc.
- 31.25kHz derived from the 2MHz RC Osc.
- 32.768kHz derived from the RTC XO
- 26MHz derived from 26MHz RC Osc.
- 6.5MHz derived from XO
- 3.25MHz derived from 26MHz RC Osc.

For clocks 26MHz and above, ensure that external pad load on the board is minimized to get a clean waveform.



## 10.9 Three-axis Quadrature Decoder

SAMB11 has a three-axis Quadrature decoder (X, Y, and Z) that can determine the direction and speed of movement on three axes, requiring in total six GPIO pins to interface with the sensors. The sensors are expected to provide pulse trains as inputs to the quadrature decoder.

Each axis channel input will have two pulses with  $\pm 90$  degrees phase shift depending on the direction of movement. The decoder counts the edges of the two waveforms to determine the speed and uses the phase relationship between the two inputs to determine the direction of motion.

The decoder is configured to interrupt ARM based on independent thresholds for each direction. Each quadrature clock counter (X, Y, and Z) is an unsigned 16-bit counter and the system clock uses a programmable sampling clock ranging from 26MHz, 13, 6.5, to 3.25MHz.

If a wake up is desired from threshold detection on an axis input, the always-on GPIO needs to be used.

# 11 Reference Design

Figure 11-1. SAMB11 – Reference Schematic.

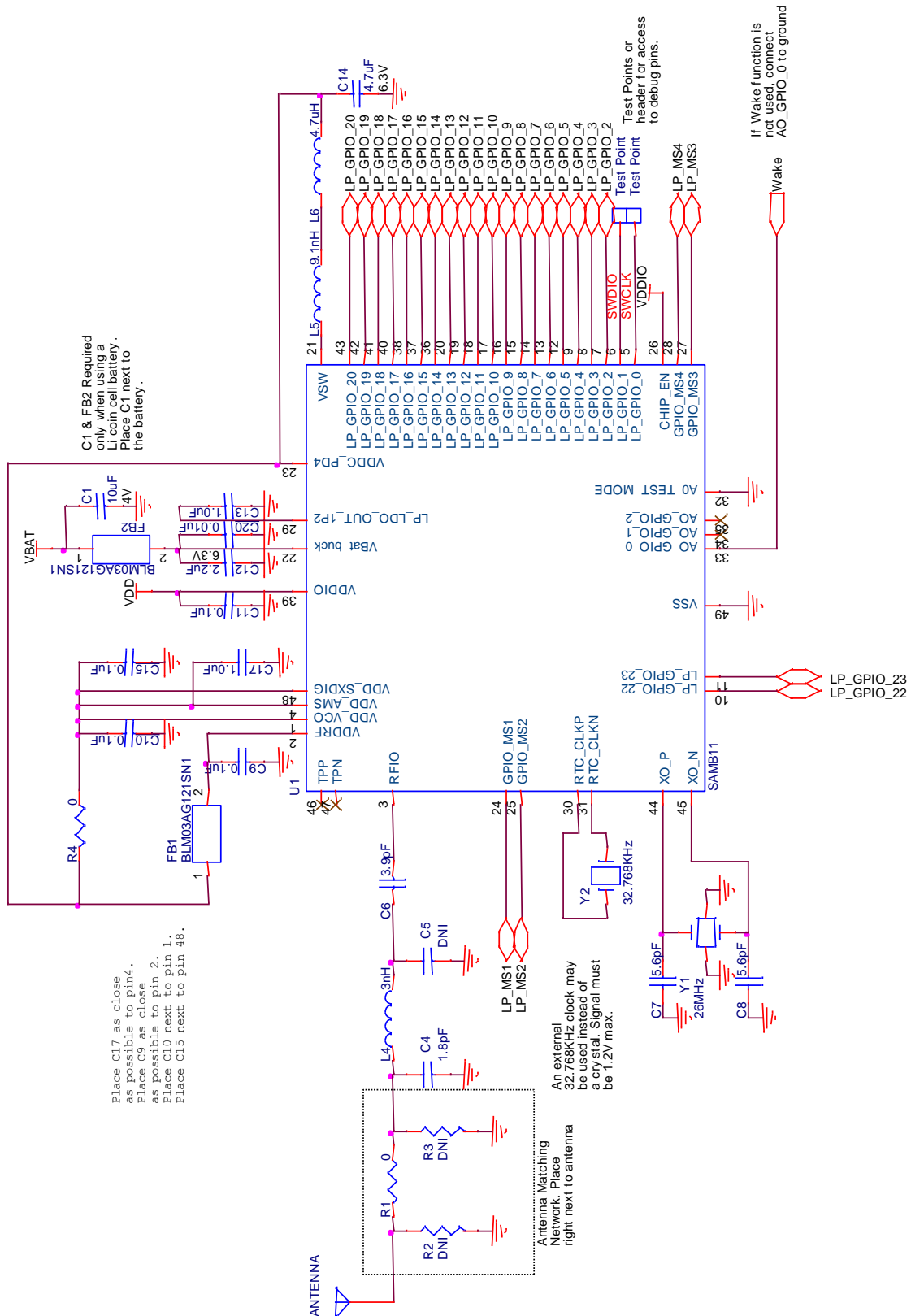

# 12 Bill of Material (BOM)

Figure 12-1. SAMB11 QFN SoC BOM

Item Qty Reference	Value	Description	Manufacturer	Part Number	Manufacturer 2	Part Number 2	Footprint
1 1 ANTENNA		Antenna, ceramic, 2.4-2.5GHz, 50ohm, -40 +85C					
2 1 C1	10uF	CAP,CER,10uF,20%,XSR,0402,4V,-55-85C	TDK	C1005XSR0G105M030BC	Taiyo Yuden	AMN105CB1106VM-F	0402
3 1 C4	1.5uF	CAP,CER,1.5uF,+/-0.1uF,NPO,0201,25V,-55-125C	TDK	C0603COG1E155RC			0201
4 1 C5	DN1	CAP,CER,1.0uF,+/-0.1uF,NPO,0201,25V,-55-125C	Murata	GRM0335C1E1R0R4011			0201
5 1 C6	3.9uF	CAP,CER,3.9uF,+/-0.1uF,NPO,0201,25V,-55-125C	Samsung	C103C9R08A3GNWC			0201
6 2 C7,C8	5.6uF	CAP,CER,5.6uF,+/-0.5uF,NPO,0201,25V,-55-125C	TDK	C0603COG1E15600300BA			0201
7 4 C9,C10,C11,C15	0.1uF	CAP,CER,0.1uF,10%,XSR,0201,6.3V,-55-125C	Murata	GRM033R60104KE119D			0201
8 1 C12	2.2uF	CAP,CER,2.2uF,10%,XSR,0402,6.3V,-55-85C	TDK	C1005XSR0225K			0402
9 1 C13	1.0uF	CAP,CER,1.0uF,20%,XSR,0201,4V,-55-85C	TDK	C0603XSR0105M030BC	Samsung	C103A105M03CSMC	0201
10 1 C14	4.7uF	CAP,CER,4.7uF,10%,XSR,0402,6.3V,-55-85C	TDK	C1005XSR0475K020BC			0402
11 1 C17	1.0uF	CAP,CER,1.0uF,20%,X65,0201,4V,-55-85C	Murata	GRM033C8G1051MEAZD			0201
12 1 C20	0.01uF	CAP,CER,0.01uF,10%,XSR,0201,10V,-55-125C	Murata	GRM033R61A103KA01D			0201
13 2 FB1,FB2	BUK93AG1215N1	FERRITE,120 OHM @100kHz,200mA,0201,-55-125C	Murata	BUK93AG1215N1			0201
14 1 L4	3mH	Inductor,3mH,+/-0.2mH,Q=13,6p500MHz,SIF=8,1GR0,0201,-55-125C	Taiyo Yuden	HCC00603S300C-T			0201
15 1 L5	9.1uH	INDUCTOR,Multilayer,9.1uH,5%,300mA,0.32 ohms Q=8@100kHz,-55C-125C,0402	Murata	UDG129HS9V100Z			0402
16 1 L6	4.7uH	INDUCTOR,unshielded,4.7uH,20%,120mA,Saturation,0.5ohms,SIF=80kHz,0603,-55-125C	TDK	ML21020M4R7WT000			0603
17 2 RL1,RL4		0 RESISTOR,Thick Film,0 ohm,0201	Panasonic	ERJ-1GNUR00C			0201
18 2 RL2,RL3	DN1	RESISTOR,Thick Film,0 ohm,0201	Panasonic	ERJ-1GNUR00C			0201
19 2 TP1,TP2	Non-component	Test Point,Surface Mount,0.0407sq w/0.25" hole					0.04" SQx0.025" H
20 1 U1	SAMB11	IC, BLE, Stacked FLASH, 480FN	Atmel	SAMB11			480FN
21 1 Y1	26MHz	CRYSTAL,26MHz,CL=8pF,20ppm temp.,-40-85C,ESR=80.2.5k2/mhz	Taitien	A01B3-X-001-3			2.5x2.0mm
22 1 Y2	32.768kHz	Crystal, 32.768kHz,+/-20ppm,-40 +85C,CL=7pF,2 load, 5M	ECS	ECS-327-7-39-TR			

SAMB11 Reference Schematic Revised: Thursday, January 21, 2016  
 SAMB11 Ref Revision: 6

Bill Of Materials February 2, 2016 17:11:44

## 13 Electrical Characteristics

There are voltage ranges where different VDDIO levels apply. The reason for this separation is for the IO drivers whose drive strength is directly proportional to the IO supply voltage. In the ATSAMB11 products, there is a gap in the IO supply voltage range (2.3 to 3.6V). A guarantee on drive strength across this voltage range would be intolerable to most vendors who only use a subsection of the IO supply range. As such, these voltages are segmented into two manageable sections referenced as VDDIO<sub>M</sub>, and VDDIO<sub>H</sub>, in tables listed in this document.

### 13.1 Absolute Maximum Ratings

The values listed in this section are ratings that can be peaked by the device, but not sustained without causing irreparable damage to the device.

**Table 13-1. SAMB11 Absolute Maximum Ratings**

Symbol	Characteristic	Minimum	Maximum	Unit
VDDIO	I/O Supply Voltage	-0.3	4.2	V
VBATT	Battery Supply Voltage	-0.3	5.0	
V <sub>IN</sub> <sup>(1)</sup>	Digital Input Voltage	-0.3	VDDIO	
V <sub>AIN</sub> <sup>(2)</sup>	Analog Input Voltage	-0.3	1.5	
V <sub>ESDHBM</sub> <sup>(3)</sup>	ESD Human Body Model	-1000, -2000(see notes below)	+1000, +2000(see notes below)	
T <sub>A</sub>	Storage Temperature	-65	150	°C
	Junction Temperature		125	

- Notes:
1. V<sub>IN</sub> corresponds to all the digital pins.
  2. V<sub>AIN</sub> corresponds to all the analog pins.
  3. For V<sub>ESDHBM</sub>, each pin is classified as Class 1, or Class 2, or both:
    - The Class 1 pins include all the pins (both analog and digital)
    - The Class 2 pins include all digital pins only
    - V<sub>ESDHBM</sub> is ±1kV for Class1 pins. V<sub>ESDHBM</sub> is ±2kV for Class2 pins

### 13.2 Recommended Operating Conditions

**Table 13-2. SAMB11 Recommended Operating Conditions**

Symbol	Characteristic	Min.	Typ.	Max.	Unit
VDDIO <sub>M</sub>	I/O Supply Voltage Mid-Range	2.30	2.50	3.00	V
VDDIO <sub>H</sub>	I/O Supply Voltage High Range	3.00	3.30	3.60	
VBATT	Battery Supply Voltage <sup>(1)</sup>	2.30	3.30	4.30	
	Operating Temperature	-40		85	°C

- Note: 1. VBATT must not be less than VDDIO.

### 13.3 DC Characteristics

Table 13-3 provides the DC characteristics for the SAMB11 digital pads.

**Table 13-3. SAMB11 DC Electrical Characteristics**

VDDIO Condition	Characteristic	Minimum	Typical	Maximum	Unit
VDDIOM	Input Low Voltage VIL	-0.30		0.63	V
	Input High Voltage VIH	VDDIO-0.60		VDDIO+0.30	
	Output Low Voltage VOL			0.45	
	Output High Voltage VOH	VDDIO-0.50			
VDDIOH	Input Low Voltage VIL	-0.30		0.65	
	Input High Voltage VIH	VDDIO-0.60		VDDIO+0.30 (up to 3.60)	
	Output Low Voltage VOL			0.45	
	Output High Voltage VOH	VDDIO-0.50			
All	Output Loading			20	pF
	Digital Input Load			6	
VDDIOM	Pad drive strength (regular pads) <sup>(1)</sup>	3.4	6.6		mA
VDDIOH	Pad drive strength (regular pads) <sup>(1)</sup>	10.5	14		
VDDIOM	Pad drive strength (high-drive pads) <sup>(1)</sup>	6.8	13.2		
VDDIOH	Pad drive strength (high-drive pads) <sup>(1)</sup>	21	28		

Note: 1. The following are high-drive pads: GPIO\_8, GPIO\_9; all other pads are regular.

## 14 Reflow Profile Information

This section provides guidelines for reflow processes in getting the Atmel module soldered to the customer's design.

### 14.1 Storage Condition

#### 14.1.1 Moisture Barrier Bag Before Opened

A moisture barrier bag must be stored in a temperature of less than 30°C with humidity under 85% RH.

The calculated shelf life for the dry-packed product shall be 12 months from the date the bag is sealed.

#### 14.1.2 Moisture Barrier Bag Open

Humidity indicator cards must be blue, < 30%.

### 14.2 Stencil Design

The recommended stencil is laser-cut, stainless-steel type with a thickness of 100µm to 130µm and approximately a 1:1 ratio of stencil opening to pad dimension. To improve paste release, a positive taper with bottom opening 25µm larger than the top can be utilized. Local manufacturing experience may find other combinations of stencil thickness and aperture size to get good results.

### 14.3 Baking Conditions

This module is rated at MSL level 3. After sealed bag is opened, no baking is required within 168 hours so long as the devices are held at  $\leq 30$  °C/60% RH or stored at <10% RH.

The module will require baking before mounting if:

The sealed bag has been open for > 168 hours.

Humidity Indicator Card reads >10%.

SIPs need to be baked for 8 hours at 125 °C.

### 14.4 Soldering and Reflow Condition

#### 14.4.1 Reflow Oven

It is strongly recommended that a reflow oven equipped with more heating zones and Nitrogen atmosphere be used for lead-free assembly. Nitrogen atmosphere has shown to improve the wet-ability and reduce temperature gradient across the board. It can also enhance the appearance of the solder joints by reducing the effects of oxidation.

The following items should also be observed in the reflow process:

1. Some recommended pastes include NC-SMQ® 230 flux and Indalloy® 241 solder paste made up of 95.5 Sn/3.8 Ag/0.7 Cu or SENJU N705-GRN3360-K2-V Type 3, no clean paste.
2. Allowable reflow soldering iterations: Three times based on the following reflow soldering profile (as shown in [Figure 14-1](#)).
3. Temperature profile:
  - Reflow soldering shall be done according to the following temperature profile (as shown in [Figure 14-1](#)).
  - The Peak temperature is 250°C.

Figure 14-1. Solder Reflow Profile

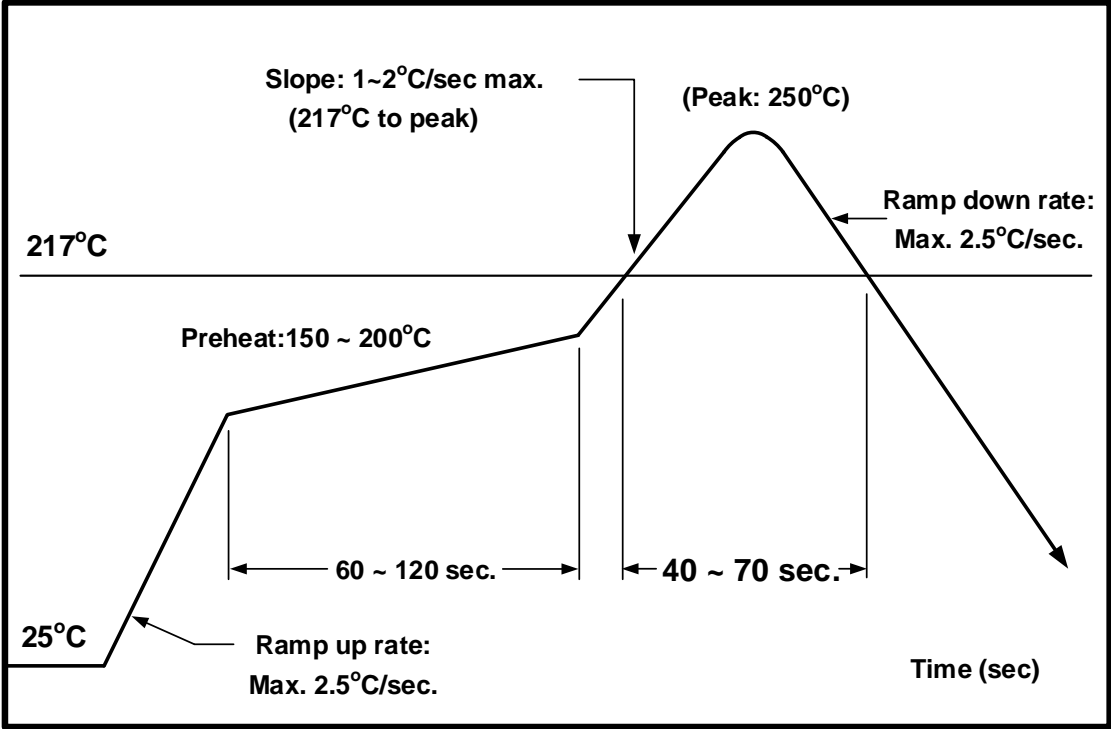

## 15 Errata

**Issue:** In the ATSAMB11 Datasheet, the measured advertisement current for the cases listed in [Table 6-3](#) will be higher than what is reported.

SDK5.0 does not resemble the same conditions where [Table 6-3](#) has been measured.

For example:

The power and timing parameters in the SDK5.0 release have not been fully optimized to their final values.

IDRAM1 and IDRAM2 are always enabled/retained for ROM patches and application development.

SDK5.0 enables clocks to different peripheral blocks to allow easier application development.

Continuous access to the SWD debug interface is needed. Therefore, debug clocks cannot be turned OFF.

A small sample measurement has been performed they show the following results:

Measurement condition:

- 1-sec adverting interval
- 37 byte advertising payload
- Connectable beacon
- Advertising on three channels (37, 38, 39)
- VBATT and VDDIO are set to 3.3V

Average advertising current: 13.65 $\mu$ A

Average sleep current between beacons: 2.00 $\mu$ A

With VBATT set to 3.6V, the average advertising current under the same conditions is 12.67 $\mu$ A.



## 16 Reference Documentation and Support

### 16.1 Reference Documents

Atmel offers a set of collateral documentation to ease integration and device ramp. The following table list documents available on Atmel website or integrated into development tools.

**Table 16-1. Reference Documents**

Title	Content
Datasheet	This document
Ultra Low Power BLE 4.1 SoC - Hardware Design Guidelines	ATSAMB11 hardware design guide with references for placement and routing, external RTC, restrictions on power states, type of information.
ATSAMB11 BluSDK Smart Release Package for Atmel Studio 7 Software	This package contains the software development kit and all the necessary documentation including getting started guides for interacting with different hardware devices, device drivers, and API call references.

For a complete listing of development support tools and documentation, visit <http://www.atmel.com/>, or contact the nearest Atmel field representative.

## 17 Document Revision History

Doc Rev.	Date	Comments
42426D	08/2016	<ol style="list-style-type: none"> <li>1. Corrected minimum voltage ranges in Features/Integrate Power Management.</li> <li>2. Revised 26MHz crystal ESR in Table 7-1.</li> <li>3. Revised <math>f_{pwm}</math> frequency minimum values in Table 10-11.</li> <li>4. Added RTC clocks to Absolute Maximum Ratings Table 13-1.</li> <li>5. Revised GPIO info in Features/Peripherals in the first page.</li> <li>6. Supplemented GPIO pin descriptions in Table 4-1.</li> <li>7. Added GPIO state behavior section 6.6.</li> <li>8. Revised resistor pull direction in Table 10-1.</li> <li>9. Revised SPI Slave Timing info in Table 10-7.</li> <li>10. Revised SPI Master Timing info in Table 10-8.</li> <li>11. Revised SPI Flash Master Timing Info in Table 10-9.</li> <li>12. Updated VDDIO values in Table 6-3, and removed Footnote 3.</li> <li>13. Removed agency RF information since there is no antenna.</li> <li>14. Added reflow profile section 14.</li> <li>15. Revised Maximum VDDIO in Table 13-1.</li> <li>16. Revised Receiver performance values in Table 9-1.</li> <li>17. Clarified RTC XO text in section 7.3.2.</li> <li>18. Added text to describe meanings for VDDIOm and VDDIOh ratings in section 13.</li> <li>19. Revised DC/DC Battery typical voltage in Table 6-1.</li> <li>20. Added Section 16 to provide reference documentation.</li> </ol>

Doc Rev.	Date	Comments
42426C	02/2016	<ol style="list-style-type: none"> <li>1. Updated current numbers and Integrated Power Management in the feature list.</li> <li>2. Updated DC/DC Converter data in section 6.2, and Table 6-1, and provided efficiency graph in Figure 6-2.</li> <li>3. Updated current numbers and added comments in Table 6-3.</li> <li>4. Updated advertising current chart in Figure 6-3.</li> <li>5. Revised Notes in Section 6.5, updated Figure 6-5 and Figure 6-6.</li> <li>6. New figure for Clock Architecture in Figure 7-1. Revised values in Table 7-1.</li> <li>7. Added new figures in Figure 7-2 and Figure 7-3.</li> <li>8. Updated capacitance value in section 7.2.</li> <li>9. Updated voltage value in Table 7-3.</li> <li>10. Added table for 26MHz on-chip programming in Table 7-4.</li> <li>11. Updated capacitance value and text in section 7.3.1.</li> <li>12. Added 32kHz RC Oscillator performance charts in Section 7.3.</li> <li>13. Revised and added more detailed data to Section 8.1.</li> <li>14. Updated eFuse and Flash information Sections 8.3, 8.4, and Figure 8-2.</li> <li>15. Updated Receiver performance numbers and comments in Table 9-1.</li> <li>16. Updated Transmitter performance numbers and comments in Table 9-2.</li> <li>17. Added notice about UART Flow Control in Section 0.</li> <li>18. Replaced the whole ADC performance Table 10-10.</li> <li>19. Revised values in SPI Slave timing in Table 10-7.</li> <li>20. Revised values on SPI Master timing in Table 10-8.</li> <li>21. Updated ADC power consumption and added comment in Table 10-9.</li> <li>22. Replaced ADC performance charts: Figure 10-8 and Figure 10-9.</li> <li>23. Added new ADC performance charts: Figure 10-10 and Figure 10-11.</li> <li>24. Added <math>f_{pwm}</math> range table in Table 10-11 for the software Programmable times.</li> <li>25. Revised reference schematics in Section 11.</li> <li>26. Revised Table 13-1 showing more Pad drive strength.</li> <li>27. Added section 14 Errata.</li> <li>28. Updated section 13 text and tables to clarify VDDIO<sub>M</sub> and VDDIO<sub>H</sub>.</li> </ol> <p>Several minor corrections in the text and according to the template.</p>

Doc Rev.	Date	Comments
42426B	07/2015	<ol style="list-style-type: none"> <li>1. Updated feature list (peripherals, clock, and power bullets).</li> <li>2. Updated pinout information in Section 4.</li> <li>3. Updated power architecture drawing in (Figure 6-1).</li> <li>4. Added DC/DC converter description (Section 6.2).</li> <li>5. Updated power consumption numbers and description (Section 6.3).</li> <li>6. Minor correction in power-up sequence (Section 6.4).</li> <li>7. Minor correction in POR and BOD description (Section 6.5).</li> <li>8. Updated clocking description, figures, charts, and numbers (Section 6.5).</li> <li>9. Updated eFuse map (Figure 8-2).</li> <li>10. Updated receiver and transmitter performance numbers (Table 9-1 and Table 9-2).</li> <li>11. Updated pin MUX description and tables (Section 10.1).</li> <li>12. Merged I2C master and slave into one section (Section 10.2).</li> <li>13. Added SPI master (Section 10.3), updated description and fixed typos in timing.</li> <li>14. Removed SPI Flash from the document.</li> <li>15. Updated ADC performance numbers and added figures (Section 0).</li> <li>16. Updated PWM numbers and added table (Section 10.7).</li> <li>17. Added Clock Output section (Section 10.8).</li> <li>18. Updated max VBATT and VDDIO voltage and added a note on VBATT (Section 13.2).</li> <li>19. Added pad drive strength numbers (Table 13-3).</li> <li>20. Miscellaneous minor updates, corrections, and formatting changes throughout the document.</li> </ol>
42426A	03/2015	Initial document release.



**Atmel Corporation**      1600 Technology Drive, San Jose, CA 95110 USA      T: (+1)(408) 441.0311      F: (+1)(408) 436.4200      | [www.atmel.com](http://www.atmel.com)

© 2016 Atmel Corporation. Rev.: Atmel-42426D-SAM-B11-Ultra-Low-Power-BLE-4.1-SoC-Datasheet\_08/2016

Atmel®, Atmel logo and combinations thereof, Enabling Unlimited Possibilities®, and others are registered trademarks or trademarks of Atmel Corporation in U.S. and other countries. ARM® and Cortex® are the registered trademarks or trademarks of ARM Ltd. Other terms and product names may be trademarks of others.

**DISCLAIMER:** The information in this document is provided in connection with Atmel products. No license, express or implied, by estoppel or otherwise, to any intellectual property right is granted by this document or in connection with the sale of Atmel products. EXCEPT AS SET FORTH IN THE ATMEL TERMS AND CONDITIONS OF SALES LOCATED ON THE ATMEL WEBSITE, ATMEL ASSUMES NO LIABILITY WHATSOEVER AND DISCLAIMS ANY EXPRESS, IMPLIED OR STATUTORY WARRANTY RELATING TO ITS PRODUCTS INCLUDING, BUT NOT LIMITED TO, THE IMPLIED WARRANTY OF MERCHANTABILITY, FITNESS FOR A PARTICULAR PURPOSE, OR NON-INFRINGEMENT. IN NO EVENT SHALL ATMEL BE LIABLE FOR ANY DIRECT, INDIRECT, CONSEQUENTIAL, PUNITIVE, SPECIAL OR INCIDENTAL DAMAGES (INCLUDING, WITHOUT LIMITATION, DAMAGES FOR LOSS AND PROFITS, BUSINESS INTERRUPTION, OR LOSS OF INFORMATION) ARISING OUT OF THE USE OR INABILITY TO USE THIS DOCUMENT, EVEN IF ATMEL HAS BEEN ADVISED OF THE POSSIBILITY OF SUCH DAMAGES. Atmel makes no representations or warranties with respect to the accuracy or completeness of the contents of this document and reserves the right to make changes to specifications and products descriptions at any time without notice. Atmel does not make any commitment to update the information contained herein. Unless specifically provided otherwise, Atmel products are not suitable for, and shall not be used in, automotive applications. Atmel products are not intended, authorized, or warranted for use as components in applications intended to support or sustain life.

**SAFETY-CRITICAL, MILITARY, AND AUTOMOTIVE APPLICATIONS DISCLAIMER:** Atmel products are not designed for and will not be used in connection with any applications where the failure of such products would reasonably be expected to result in significant personal injury or death ("Safety-Critical Applications") without an Atmel officer's specific written consent. Safety-Critical Applications include, without limitation, life support devices and systems, equipment or systems for the operation of nuclear facilities and weapons systems. Atmel products are not designed nor intended for use in military or aerospace applications or environments unless specifically designated by Atmel as military-grade. Atmel products are not designed nor intended for use in automotive applications unless specifically designated by Atmel as automotive-grade.

# Mouser Electronics

Authorized Distributor

Click to View Pricing, Inventory, Delivery & Lifecycle Information:

[Microchip:](#)

[ATSAMB11G18A-MU-Y](#) [ATSAMB11G18A-MU-T](#) [ATSAMB11ZR-XPRO](#)

Компания «Life Electronics» занимается поставками электронных компонентов импортного и отечественного производства от производителей и со складов крупных дистрибьюторов Европы, Америки и Азии.

С конца 2013 года компания активно расширяет линейку поставок компонентов по направлению коаксиальный кабель, кварцевые генераторы и конденсаторы (керамические, пленочные, электролитические), за счёт заключения дистрибьюторских договоров

Мы предлагаем:

- Конкурентоспособные цены и скидки постоянным клиентам.
- Специальные условия для постоянных клиентов.
- Подбор аналогов.
- Поставку компонентов в любых объемах, удовлетворяющих вашим потребностям.
- Приемлемые сроки поставки, возможна ускоренная поставка.
- Доставку товара в любую точку России и стран СНГ.
- Комплексную поставку.
- Работу по проектам и поставку образцов.
- Формирование склада под заказчика.
- Сертификаты соответствия на поставляемую продукцию (по желанию клиента).
- Тестирование поставляемой продукции.
- Поставку компонентов, требующих военную и космическую приемку.
- Входной контроль качества.
- Наличие сертификата ISO.

В составе нашей компании организован Конструкторский отдел, призванный помогать разработчикам, и инженерам.

Конструкторский отдел помогает осуществить:

- Регистрацию проекта у производителя компонентов.
- Техническую поддержку проекта.
- Защиту от снятия компонента с производства.
- Оценку стоимости проекта по компонентам.
- Изготовление тестовой платы монтаж и пусконаладочные работы.



Тел: +7 (812) 336 43 04 (многоканальный)

Email: [org@lifeelectronics.ru](mailto:org@lifeelectronics.ru)