

features

- Low dielectric loss at high frequency (high Q)
- Narrow tolerance of capacitance
- Excellent temperature characteristics
- High reliability and no polarity by single layer ceramic substrate construction
- 0.10 - 1.3 pF available by 0.05 pF range (HFC1005 series)
- 0.10 - 1.20 pF available by 0.05 pF range (HFC1410, 1608, 1610, 1612 series)
- Marking: Brown body color with no marking
- Products with lead-free terminations meet EU RoHS requirements

dimensions and construction

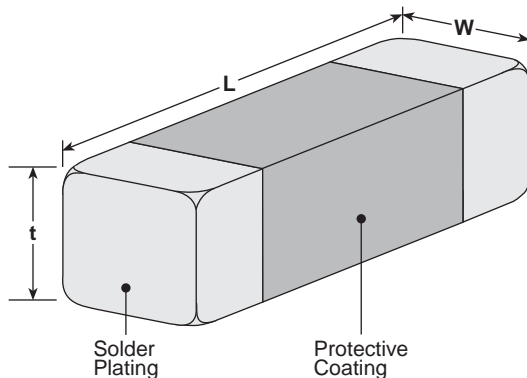

Size	Dimensions inches (mm)		
	L	W	t
1005	.039±.006 (1.0±0.15)	.02±.004 (0.5±0.1)	.02±.004 (0.5±0.1)
1410	.055±.006 (1.4±0.15)	.039±.004 (1.0±0.1)	.039±.004 (1.0±0.1)
1608	.063±.006 (1.6±0.15)	.031±.004 (0.8±0.1)	.028±.008 (0.7±0.2)
1610	.063±.006 (1.6±0.15)	.039±.004 (1.0±0.1)	.033±.01 (0.85±0.25)
1612	.063±.006 (1.6±0.15)	.047±.004 (1.2±0.1)	.043±.008 (1.1±0.2)

capacitors

ordering information

New Part #	HFC	1608	C	T	TD	R10
	Type	Size	Material Code	Termination Material	Packaging	Nominal Capacitance
		1005: 1.0 x 0.5 mm 1410: 1.4 x 1.0 mm 1608: 1.6 x 0.8 mm 1610: 1.6 x 1.0 mm 1612: 1.6 x 1.2 mm	B C G H K N S T V W	T: Sn	TD: Paper tape (1005 only - 10,000 pieces/reel) TE: Embossed taping (1410, 1610, 1612 - 3,000 pieces/reel) (1608 - 4,000 pieces/reel)	2 significant digits + zeros "R" indicates decimal point

For further information on packaging, please refer to Appendix A.

characteristics of dielectric materials

HFC1005 Series

Material Code	ϵ_r	τ_r (ppm/°C)
T	37.0±1.5	0±10
N	70.0±3.0	6±10
K	92.0±2.0	6±10
V	113.0±5.0	30±10
H	140.0±3.0	0±30
G	160.0±4.0	0±30
S	180.0±4.0	0±30

HFC1005 Series (continued)

Material Code	ϵ_r	τ_r (ppm/°C)
B	200.0±5.0	0±30
W	260.0±5.0	0±60

HFC1410, 1608, 1610, 1612 Series

Material Code	ϵ_r	τ_r (ppm/°C)
C	21.5±2.0	0±10
T	37.0±1.5	0±10
N	70.0±3.0	6±10
V	113.0±5.0	30±10

applications and ratings

Part Designation	Capacitance (pF)	Tolerance Code (pF)	Material Code	Rated Voltage DC (V)	Operating Temperature Range	
HFC1005TTTDR10	0.10	±0.015	T	50	-55°C to +125°C	
HFC1005TTTDR15	0.15					
HFC1005NTTDR20	0.20	±0.030	N			
HFC1005NTTDR25	0.25					
HFC1005KTTDR30	0.30		K			
HFC1005KTTDR35	0.35					
HFC1005VTTDR40	0.40		V			
HFC1005VTTDR45	0.45					
HFC1005VTTDR50	0.50					
HFC1005VTTDR55	0.55					
HFC1005VTTDR60	0.60		±0.050			H
HFC1005HTTDR65	0.65					
HFC1005HTTDR70	0.70	G				
HFC1005HTTDR75	0.75					
HFC1005GTTDR80	0.80					
HFC1005GTTDR85	0.85					
HFC1005GTTDR90	0.90	S				
HFC1005GTTDR95	0.95					
HFC1005STTD1R0	1.00					
HFC1005BTTD1R1	1.10	B				
HFC1005WTTD1R2	1.20					
HFC1005WTTD1R3	1.30					

Specifications given herein may be changed at any time without prior notice. Please confirm technical specifications before you order and/or use.

3/10/07

applications and ratings (continued)

Part Designation	Capacitance (pF)	Tolerance Code (pF)	Material Code	Rated Voltage DC (V)	Operating Temperature Range				
HFC1410VTTE1R1	1.10	±0.075	V	50	-55°C to +125°C				
HFC1410VTTE1R2	1.20								
HFC1410VTTE1R3	1.30								
HFC1608CTTER10	0.10	±0.015	C	50	-55°C to +125°C				
HFC1608TTTER15	0.15		T						
HFC1608NTTER20	0.20	±0.030	N	50	-55°C to +125°C				
HFC1608NTTER25	0.25								
HFC1608NTTER30	0.30								
HFC1608NTTER35	0.35								
HFC1608VTTER40	0.40								
HFC1608VTTER45	0.45		V						
HFC1608VTTER50	0.50								
HFC1608VTTER55	0.55								
HFC1610VTTER60	0.60					±0.030	V	50	-55°C to +125°C
HFC1610VTTER65	0.65								
HFC1610VTTER70	0.70								
HFC1610VTTER75	0.75	±0.050	V	50	-55°C to +125°C				
HFC1610VTTER80	0.80								
HFC1610VTTER85	0.85								
HFC1610VTTER90	0.90								
HFC1612VTTER95	0.95					±0.050	V	50	-55°C to +125°C
HFC1612VTTE1R0	1.00								

capacitors

environmental applications

HFC1410, 1608, 1610, 1612 Series Type: HFC1612VT1R0R05M50 (1.0 PF)

Self Resonant Frequency (SRF) vs. Capacitance Value

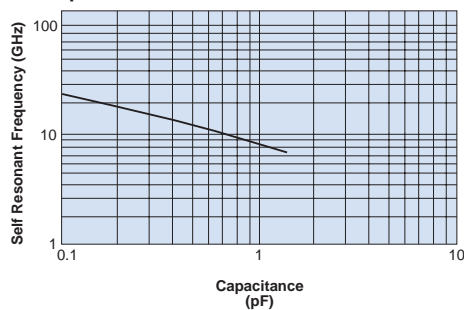

Q vs. Frequency

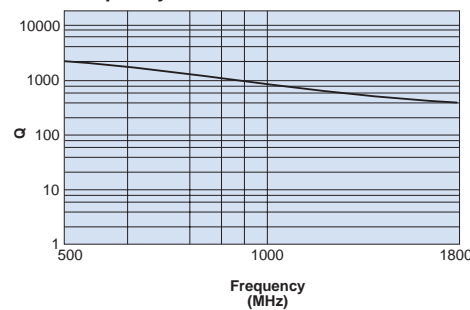

ESR vs. Frequency

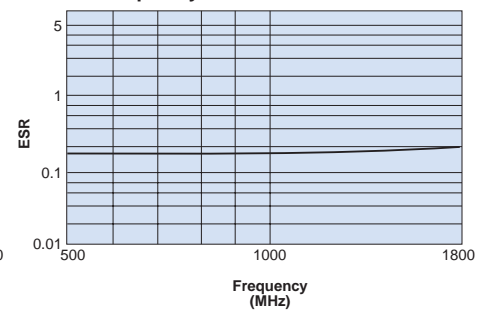

environmental applications (continued)

Electrical Characteristics

Parameter	Requirement	Test Method
Capacitance	Within the specified tolerance of parts	Frequency: 1 MHz Voltage: 1 Vrms Instrument: YHP4278A
Q Value	100 or more	Frequency: 1 MHz Voltage: 1 Vrms Instrument: YHP4278A
Insulation Resistance	10,000 MΩ or more	Test Voltage: Rated voltage Electrification Time: 60 seconds ± 5 seconds
Breakdown Voltage	No breakdown	Test Voltage: 300% of the rated voltage Electrification Time: 1 second to 5 seconds Limit Surge Current: 50 mA or less

Mechanical Characteristics

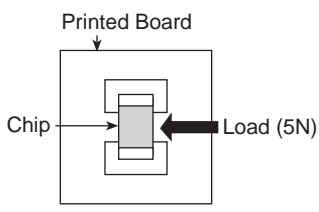
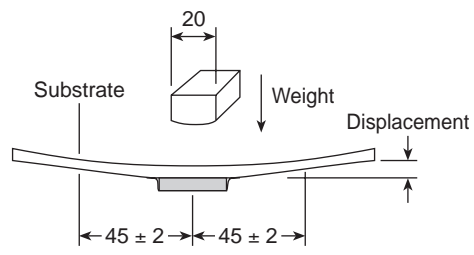
Parameter	Requirement	Test Method
Adhesion of Electrodes	No mechanical damage	A static load of 5N (0.5 kgf) shall be applied in the direction of the arrow as follows 
Core Body Strength	No mechanical damage	A static load of 5N (0.5 kgf) using a R 0.5 pressure rod shall be applied on the core of the component and held for 10 seconds
Substrate Bending Test	Visual Examination: No mechanical damage Capacitance: Within ±2.0% or ±0.02 pF whichever is more Q value: 100 or more Insulation Resistance: 10,000 MΩ or more	Solder a specimen to the substrate and bend it (Displacement: 2mm) 

environmental applications (continued)

Endurance Characteristics

Parameter	Requirement	Test Method
Solderability	A new coating of solder shall cover a minimum of 95% of the surface being immersed	Flux: 25 wt% colophony Solder: H60A (silver 3%) Preheating: 150°C for 1 minute Soldering Temperature: 230°C ± 5°C Soldering Temperature: 215°C ± 5°C (HFC1005) Immersion Time: 3 seconds ± 1 second
Resistance to Solder Heat	Visual Examination: No mechanical damage Capacitance: Within ±2.0% or ±0.02 pF whichever is more Q value: 100 or more Insulation Resistance: 10,000 MΩ or more	Flux: 25 wt% colophony Solder: H60A (silver 3%) Soldering Temperature: 270°C ± 5°C Immersion Time: 10 seconds ± 1 second
Resistance to Humidity (Load Test)		Temperature: 60°C ± 2°C Relative Humidity: 95% RH Test Voltage: Rated voltage Test Hours: 1000 -0/+48 hours
Resistance to Humidity (Unload Test)		Temperature: 85°C ± 2°C Relative Humidity: 85% RH Test Hours: 1000 -0/+48 hours
Resistance to High Temperature		Temperature: 125°C ± 2°C Test Voltage: Rated voltage Test Hours: 1000 -0/+48 hours
Resistance to Low Heat		Temperature: -55°C ± 2°C Test Hours: 1000 -0/+48 hours
Temperature Cycle		Temperature: -55°C for 30 min., 125°C for 30 min. Hours for 1 Cycle: 2 hours Temperature Cycle: 50 cycles or more
Vibration		Frequency of Vibration: 10 to 100 Hz Sweeping: 10→100→10 Hz, 5 minutes, 5.0 G This motion shall be applied for a period of 2 hours in each of 3 mutually perpendicular axis
Shock		Half of sine wave (100 G) shall be applied for a period of 5 msec. in each of 3 mutually perpendicular axis

capacitors

The specimen shall be subjected to standard atmospheric condition for 24 hours after which measurement shall be made.

Компания «Life Electronics» занимается поставками электронных компонентов импортного и отечественного производства от производителей и со складов крупных дистрибьюторов Европы, Америки и Азии.

С конца 2013 года компания активно расширяет линейку поставок компонентов по направлению коаксиальный кабель, кварцевые генераторы и конденсаторы (керамические, пленочные, электролитические), за счёт заключения дистрибьюторских договоров

Мы предлагаем:

- Конкурентоспособные цены и скидки постоянным клиентам.
- Специальные условия для постоянных клиентов.
- Подбор аналогов.
- Поставку компонентов в любых объемах, удовлетворяющих вашим потребностям.
- Приемлемые сроки поставки, возможна ускоренная поставка.
- Доставку товара в любую точку России и стран СНГ.
- Комплексную поставку.
- Работу по проектам и поставку образцов.
- Формирование склада под заказчика.
- Сертификаты соответствия на поставляемую продукцию (по желанию клиента).
- Тестирование поставляемой продукции.
- Поставку компонентов, требующих военную и космическую приемку.
- Входной контроль качества.
- Наличие сертификата ISO.

В составе нашей компании организован Конструкторский отдел, призванный помогать разработчикам, и инженерам.

Конструкторский отдел помогает осуществить:

- Регистрацию проекта у производителя компонентов.
- Техническую поддержку проекта.
- Защиту от снятия компонента с производства.
- Оценку стоимости проекта по компонентам.
- Изготовление тестовой платы монтаж и пусконаладочные работы.



Тел: +7 (812) 336 43 04 (многоканальный)

Email: org@lifeelectronics.ru