

700mA High Voltage Adjustable Current Regulator With Enable Control

TO-252-5L
(PPAK)



Pin Definition:

1. VIN
2. ISET
3. GND
4. EN
5. OUT

General Description

The TS19601 is a high voltage, low dropout current regulator of maximum output current up to 700mA. The output current is decided by an external resistor, and the output sink current could be disabled via OE pin. TS19601 has internally also build-in thermal protection to prevent the chip over heat damage.

Features

- 0.5V V_{DROP} @ 700mA
- 700mA Maximum Output Current
- Output Current Controlled by External Resistor
- 3 μ s Fast Response Output Stage Enable Control
- Output Sustaining Voltage up to 75V
- Wide Supply Voltage Range: 5~50V

Applications

- High Power LED Driver
- RGB Full Color Power LED Driver
- LCD Monitor/TV LED Backlight Driver
- LED Table Lamp

Typical Application Circuit

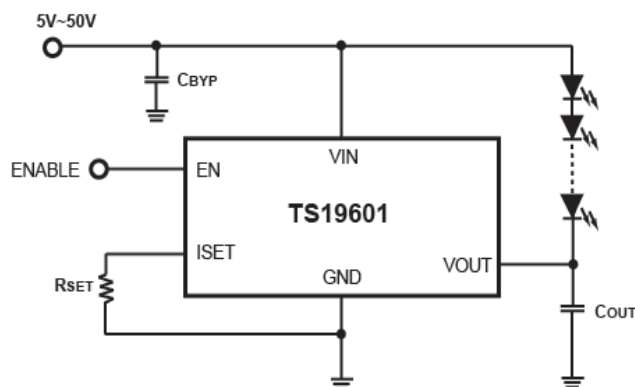

Ordering Information

Part No.	Package	Packing
TS19601CP5 ROG	TO-252-5L	2.5kpcs / 13" Reel

Note: "G" denotes for Halogen- and Antimony-free as those which contain <900ppm bromine, <900ppm chlorine (<1500ppm total Br + Cl) and <1000ppm antimony compounds

Absolute Maximum Rating

Parameter	Symbol	Value	Unit
Input Voltage	V_{IN}	55	V
Output Sustaining Voltage	V_{DSN}	75	V
Output Sink Current	I_{OUT}	700	mA
Output Enable Voltage	V_{EN}	13.2	V
Operating Junction Temperature Range	T_{OPR}	+150	$^{\circ}$ C
Storage Temperature Range	T_{STG}	-55 ~ +150	$^{\circ}$ C

Thermal Information (Note 1)

Parameter	Symbol	Range	Unit
Thermal Resistance Junction to Air	$R_{\theta JA}$	80	$^{\circ}$ C/W

700mA High Voltage Adjustable Current Regulator With Enable Control

Recommend Operating Conditions

Parameter	Symbol	Min	Typ	Max	Unit
Input Voltage	V_{IN}	5	--	50	V
Output Enable Voltage	V_{EN}	--	--	12	V
Output Sink Current	T_{OPR}	100	--	700	mA
Operating Free-Air Temperature Range	T_{STG}	-40	--	+85	°C

Electrical Specification ($V_{IN}=24V$, $T_C=25^{\circ}C$, unless otherwise specified.)

Parameter	Conditions	Min	Typ	Max	Unit
Output Current	$V_{OUT}=0.5V$, $R_{SET}=3k\Omega$	--	200	--	mA
	$V_{OUT}=0.5V$, $R_{SET}=1.71k\Omega$	--	350	--	
	$V_{OUT}=0.5V$, $R_{SET}=1k\Omega$	--	600	--	
Output Current Deviation	$V_{OUT}=0.5V$, $I_{OUT}=350mA\sim 600mA$	--	--	± 5	%
SET Current Range		200	--	1400	μA
Minimum Output Current	$I_{SET}=200\mu A$	--	100	--	mA
Maximum Output Current	$I_{SET}=1400\mu A$	--	700	--	mA
Output Dropout Voltage	$I_{SET}=1000\mu A$ (Note 2)	--	0.35	--	V
Load Regulation	$V_{OUT}=0.5V$ to $3V$, $I_{OUT}=350mA$	--	--	3	mA/V
Line Regulation	$V_{OUT}=0.5V$, $I_{OUT}=350mA$, $V_{IN}=5\sim 50V$	--	0.08	0.15	%/V
Enable Low Input Voltage		0	--	0.8	V
Enable High Input Voltage	Should lower than V_{IN}	2	--	12	V
Enable Low Input Current		-20	--	+20	μA
Enable High Input Current		-5	--	+5	μA
Output Enable Delay Time	EN from low to high. $V_{OUT}=0.5V$, $I_{OUT}=350mA$, Duty 50%	--	3	--	μs
Output Disable Delay Time	EN from high to low. $V_{OUT}=0.5V$, $I_{OUT}=350mA$, Duty 50%	--	3	--	μs
Supply Current Consumption		--	--	5	mA

Note :

1. Thermal Resistance is specified with the component mounted on a low effective thermal conductivity test board in free air at $T_A=25^{\circ}C$.
2. Output Dropout Voltage: Duty 90% x $I_{OUT}@V_{OUT}=0.5V$.

Pin Function Description

Pin Number	Pin Name	Pin Function
1	V_{IN}	Power Supply Pin
2	ISET	Output Current Setting pin. Connect a resistor from ISET to GND to set the LED bias current. $I_{SET}=1.2V/R_{SET}$
3	GND	Ground Pin
4	EN	Output Stage Enable Control pin. High enable the output pin. It can be left floating for normally on.
5	OUT	Output pin. Sink current is decided by the current on R_{SET} connected to I_{SET} pin. $I_{OUT}=500 \times I_{SET}=500 \times 1.2V/R_{SET}$

Electrical Characteristics Curve

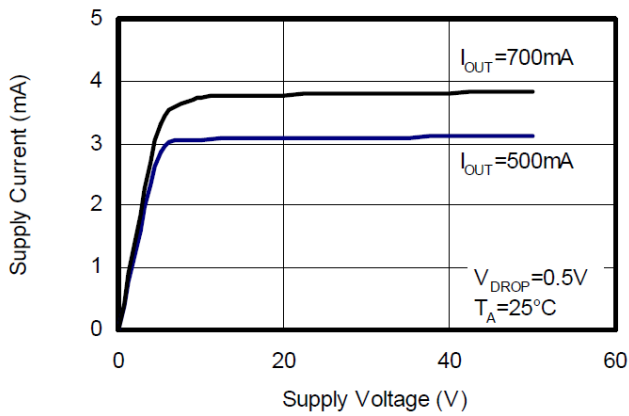

Figure 1. Supply Current vs. Supply Voltage

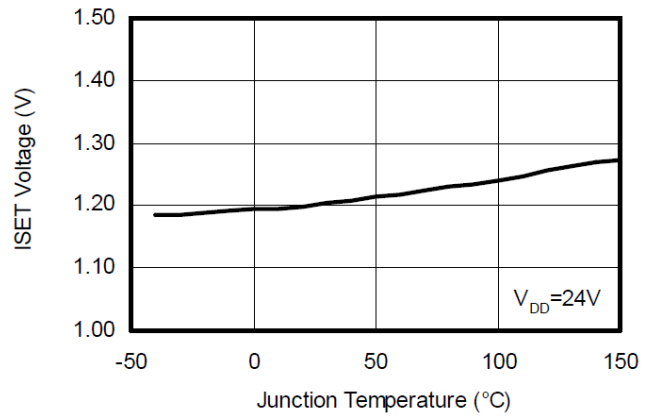

Figure 2. ISET Voltage vs. Junction Temperature

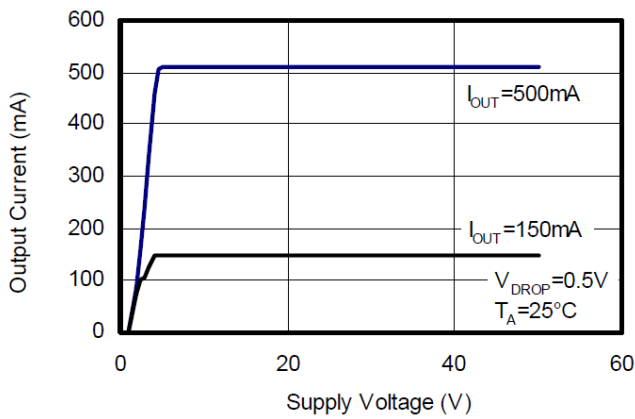

Figure 3. Output Current vs. Supply Voltage

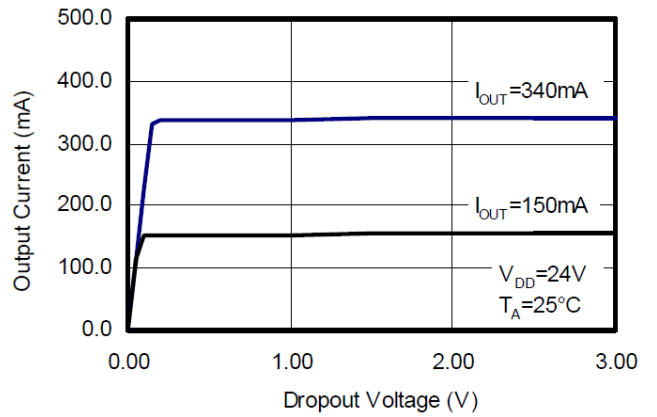

Figure 4. Output Current vs. Dropout Voltage

700mA High Voltage Adjustable Current Regulator With Enable Control

Application Information

TS19601 is a high voltage, low dropout current regulator for maximum output current up to 700mA with OE pin control. The current could be linearly adjusted through variable resistor connected to ISET pin, or by PWM control via OE pin. Although the absolute maximum rating of OUT pin 75V, the dropout voltage between OUT pin and GND pin should not be too large when current is sinking because of the thermal dissipation capability of the package.

Here are some of the typical application examples:

DC Voltage Input

Any DC voltage level between 5V to 50V could be adopted as power source VDD for typical application of TS19601 as long as VDD is larger than the total forward voltage drop of the LED string (at expecting current) by 0.35V. If 50V ~ 60V voltage level is adopted as power source to positive end of the LED string, one Zener shunt regulator could be used to provide appropriate voltage to VDD pin.

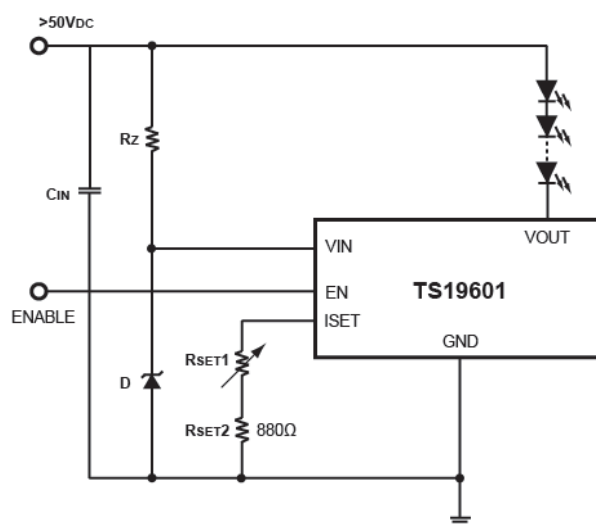
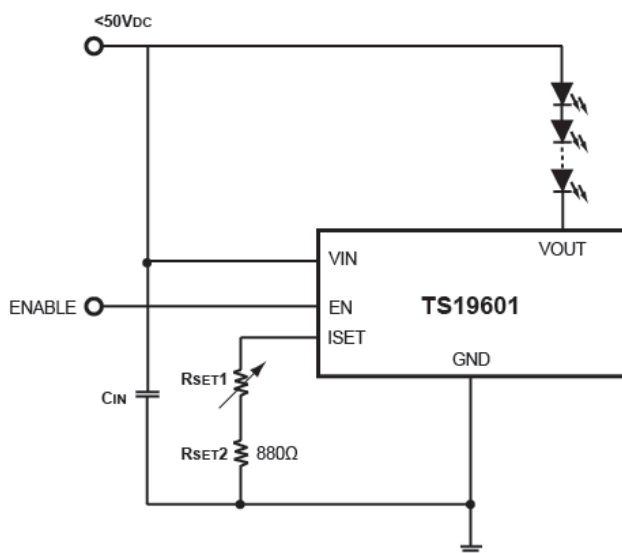

700mA High Voltage Adjustable Current Regulator With Enable Control

Application Information (Continue)

LED Backlight Solution

TS19601 could coordinate with any type of DC-to-DC converter through feedback path to realized LED backlight module. The number of LEDs in the string is variable even with certain fixed power source since the output voltage of the DC-to-DC converter could be modulated according to feedback signal.

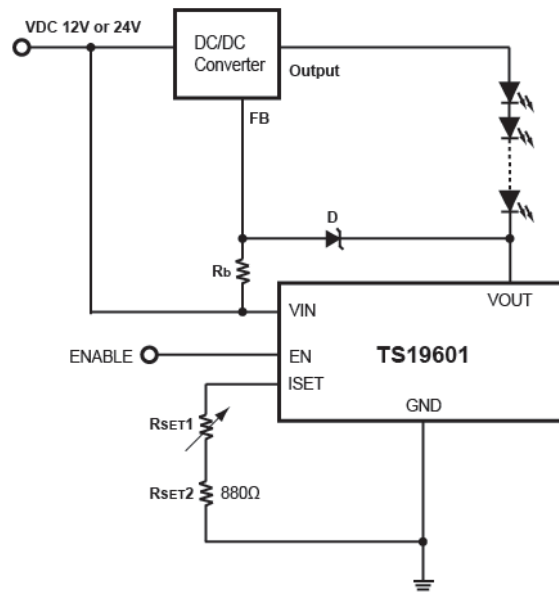

AC Voltage Input

TS19601 could work with any kind of well-known or well-developed switch-mode power supply system. Simply cut off the internal feedback path of the power supply system and then feed the signal from TS19601 back to the power supply system instead.

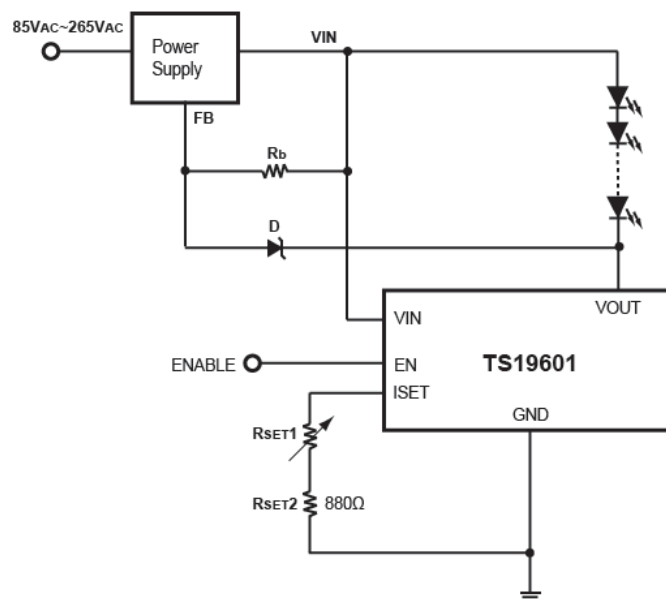

Thermal Consideration Information

The Maximum Power Dissipation on Current Regulator

$$P_{D(MAX)} = V_{OUT(MAX)} \times I_{OUT(NOM)} + V_{IN(MAX)} \times I_{DD}$$

Where :

- $V_{OUT(MAX)}$ = the maximum voltage on output pin;
- $I_{OUT(NOM)}$ = the nominal output current;
- I_{DD} = the quiescent current the regulator consumes at $I_{OUT(NOM)}$;
- $V_{IN(MAX)}$ = the maximum input voltage.

Thermal Consideration

The TS19601 has internal power and thermal limiting circuitry designed to protect the device under overload conditions. However, maximum junction temperature ratings should not be exceeded under continuous normal load conditions. The thermal protection circuit of TS19601 prevents the device from damage due to excessive power dissipation. When the device junction temperature rises to approximately 150°C, the regulator will be turned off. When power consumption is over about 1000mW (TO-252 package, at $T_A=70^\circ\text{C}$), additional heat sink is required to control the junction temperature below 125°C.

The junction temperature is:

$$T_J = P_D (R_{\theta JT} + R_{\theta CS} + R_{\theta SA}) + T_A$$

Where :

- P_D : Dissipated power.
- $R_{\theta JT}$: Thermal resistance from the junction to the mounting tab of the package.
For TO-252 package, $R_{\theta JT} = 7.0^\circ\text{C/W}$.
- $R_{\theta CS}$: Thermal resistance through the interface between the IC and the surface on which it is mounted.
(typically, $R_{\theta CS} < 1.0^\circ\text{C/W}$)
- $R_{\theta SA}$: Thermal resistance from the mounting surface to ambient (thermal resistance of the heat sink).

If PC Board copper is going to be used as a heat sink, below table can be used to determine the appropriate size of copper foil required. For multi-layered PCB, these layers can also be used as a heat sink. They can be connected with several through-holes via.

PCB $R_{\theta JA}$ °C/W	59	45	38	33	27	24	21
PCB heat sink size	500	1000	1500	2000	3000	4000	5000

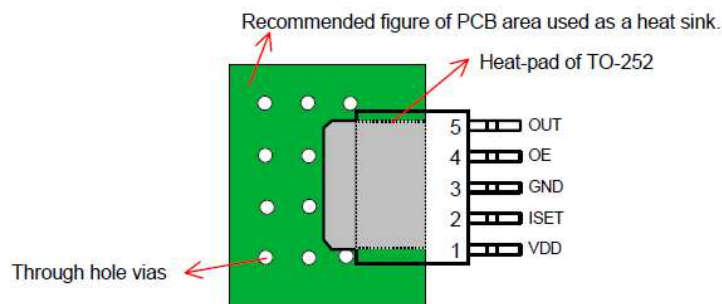

TO-252-5L Mechanical Drawing

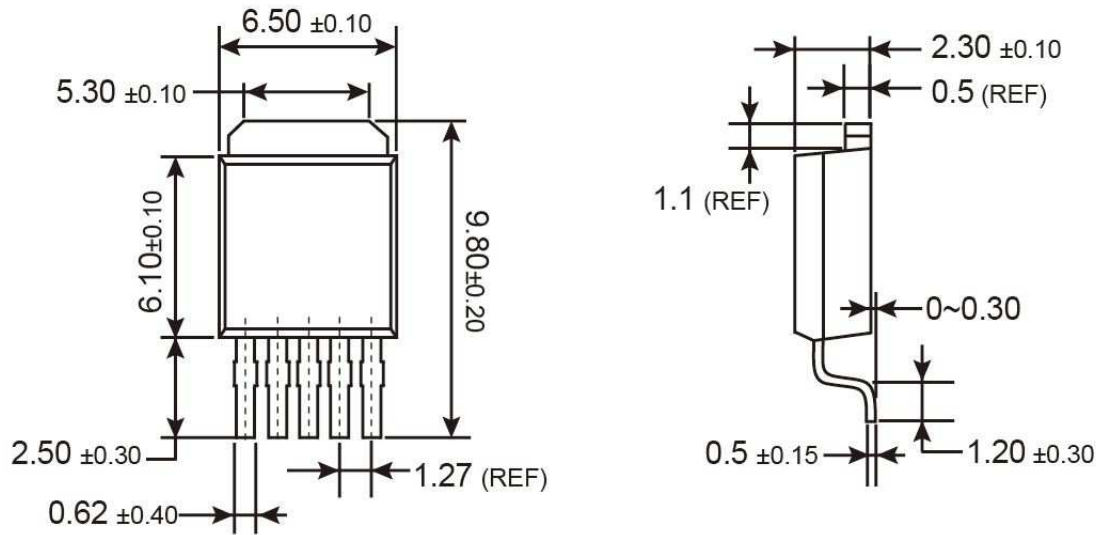

Unit: Millimeters

Marking Diagram

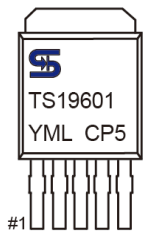

- Y** = Year Code
- M** = Month Code for Halogen Free Product
 - O** =Jan **P** =Feb **Q** =Mar **R** =Apr
 - S** =May **T** =Jun **U** =Jul **V** =Aug
 - W** =Sep **X** =Oct **Y** =Nov **Z** =Dec
- L** = Lot Code

TS19601

700mA High Voltage Adjustable Current Regulator With Enable Control

Notice

Specifications of the products displayed herein are subject to change without notice. TSC or anyone on its behalf, assumes no responsibility or liability for any errors or inaccuracies.

Information contained herein is intended to provide a product description only. No license, express or implied, to any intellectual property rights is granted by this document. Except as provided in TSC's terms and conditions of sale for such products, TSC assumes no liability whatsoever, and disclaims any express or implied warranty, relating to sale and/or use of TSC products including liability or warranties relating to fitness for a particular purpose, merchantability, or infringement of any patent, copyright, or other intellectual property right.

The products shown herein are not designed for use in medical, life-saving, or life-sustaining applications. Customers using or selling these products for use in such applications do so at their own risk and agree to fully indemnify TSC for any damages resulting from such improper use or sale.

Компания «Life Electronics» занимается поставками электронных компонентов импортного и отечественного производства от производителей и со складов крупных дистрибьюторов Европы, Америки и Азии.

С конца 2013 года компания активно расширяет линейку поставок компонентов по направлению коаксиальный кабель, кварцевые генераторы и конденсаторы (керамические, пленочные, электролитические), за счёт заключения дистрибьюторских договоров

Мы предлагаем:

- Конкурентоспособные цены и скидки постоянным клиентам.
- Специальные условия для постоянных клиентов.
- Подбор аналогов.
- Поставку компонентов в любых объемах, удовлетворяющих вашим потребностям.
- Приемлемые сроки поставки, возможна ускоренная поставка.
- Доставку товара в любую точку России и стран СНГ.
- Комплексную поставку.
- Работу по проектам и поставку образцов.
- Формирование склада под заказчика.
- Сертификаты соответствия на поставляемую продукцию (по желанию клиента).
- Тестирование поставляемой продукции.
- Поставку компонентов, требующих военную и космическую приемку.
- Входной контроль качества.
- Наличие сертификата ISO.

В составе нашей компании организован Конструкторский отдел, призванный помогать разработчикам, и инженерам.

Конструкторский отдел помогает осуществить:

- Регистрацию проекта у производителя компонентов.
- Техническую поддержку проекта.
- Защиту от снятия компонента с производства.
- Оценку стоимости проекта по компонентам.
- Изготовление тестовой платы монтаж и пусконаладочные работы.



Тел: +7 (812) 336 43 04 (многоканальный)

Email: org@lifeelectronics.ru