

HC-23724-000

SHT 1.1

NOTE:

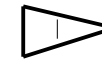

LOCATED FROM TWO SURFACES FOR CUSTOMER CONVENIENCE. ONLY APPLICABLE FROM ONE SURFACE, NOT TO BE USED TOGETHER. HORIZONTAL LOCATION FOR TERMINAL CENTERED TO ±0,17 [.007]

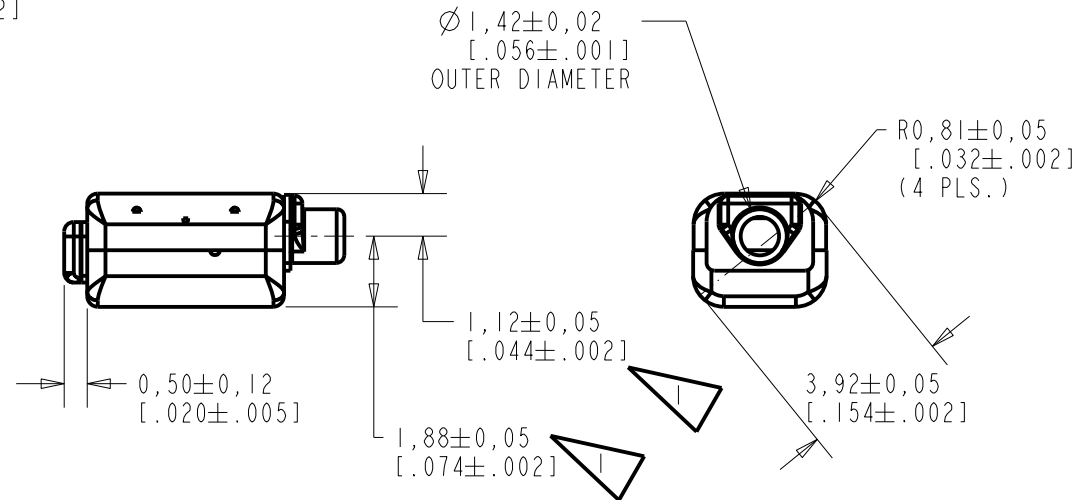
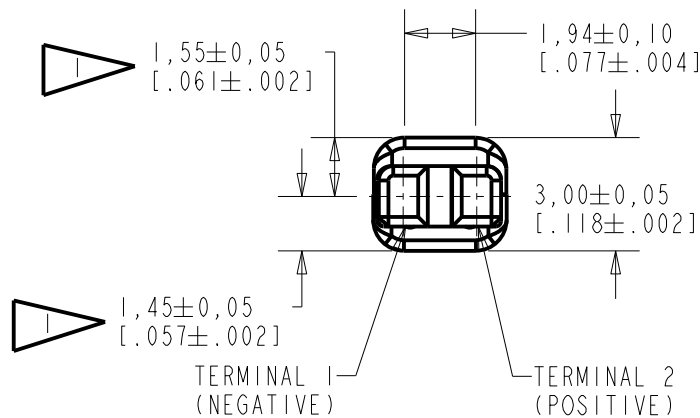
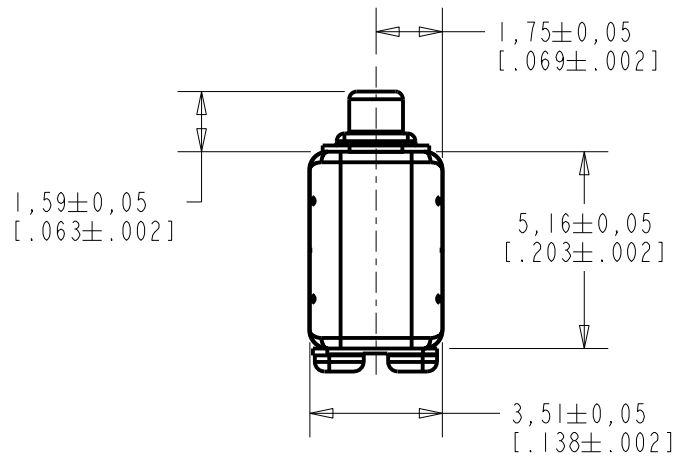

SCALE 2:1

NOMINAL WEIGHT
.23 GRAMS

DIMENSIONS IN MILLIMETERS [INCHES]

KNOWLES ELECTRONICS
ITASCA, ILLINOIS U.S.A.

Revision	C.O. #	Implementation Date	RELEASE LEVEL	REVISION
			Active	D
D	CI0115023P	10-14-13		

SCALE: 5:1		DR. BY: AB	DATE: 11-29-05
DO NOT SCALE DRAWING			
TITLE: RECEIVER		HC-23724-000	
OUTLINE DRAWING		SHT 1.1	
		CK. BY: GJP	DATE: 12-5-05
		APP. BY: GJP	DATE: 12-5-05

DESCRIPTION

NO DAMPING

HC-23724-000

SHEET 2.1

THE HC-23724-000 IS A MAGNETIC BALANCED ARMATURE RECEIVER INTENDED FOR USE IN ITC AND CIC HEARING INSTRUMENTS. THE HC FAMILY OFFERS 6 dB HIGHER OUTPUT LEVELS IN THE SAME SIZE PACKAGE AS THE FC FAMILY. ALL HC UNITS HAVE SHOCK PROTECTION. THIS MODEL HAS MEDIUM-LOW IMPEDANCE AND IS UNDAMPED.

NOTE: SPECIFICATIONS FOLLOWED BY AN ASTERISK (*) ARE 100% TESTED.

CONSTANT VOLTAGE DRIVE RESPONSE

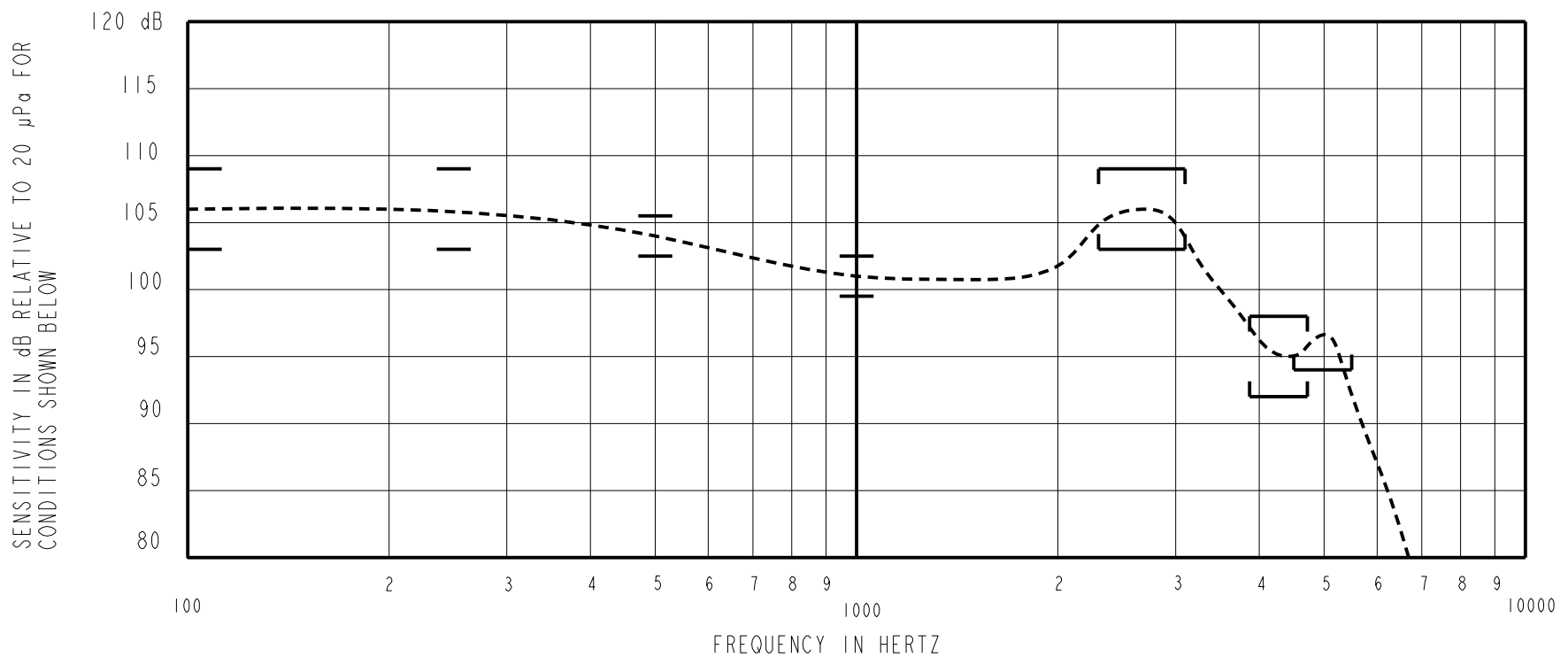

ACOUSTICAL

SENSITIVITY*

DEVICE WILL PRODUCE THE SPL LISTED BELOW WITH THE TEST CONDITIONS DESCRIBED IN TABLE 3. NOMINAL SENSITIVITY AT 1 kHz IS dB RELATIVE TO 20µPa. ALL OTHER VALUES IN dB RELATIVE TO THE SENSITIVITY AT 1 kHz.

FREQUENCY (Hz)	MINIMUM	NOMINAL	MAXIMUM
100	+2.0	+5.0	+8.0
250	+2.0	+5.0	+8.0
500	+1.5	+3.0	+4.5
1000	-1.5	101.0	+1.5
2300-3100 PEAK	+2.0	+5.0	+8.0
3680-4720 VALLEY	-9.0	-6.0	-3.0
4500-5500 PEAK	-7.0	---	---

TABLE 1.

TOTAL HARMONIC DISTORTION*

DEVICE WILL NOT EXCEED TOTAL HARMONIC DISTORTION LEVELS LISTED BELOW.

FREQUENCY (Hz)	DRIVE (Vrms)	DC BIAS (mA)	LIMIT (%)
900	.200 V	0	5
1350	.200 V	0	5
500	.564 V	0	10

TABLE 2.

TEST CONDITIONS

NOMINAL SOURCE VOLTAGE	.200 Vrms, 0 mA DC BIAS
SOURCE IMPEDANCE	< 1 Ω
TUBING	10 mm (.394) LONG, 1 mm (.039) ID.
COUPLER CAVITY	2 CC SIMULATED ANSI S3.7 TYPE HA-3, (IEC 60318-5)

TABLE 3.

POLARITY *

POSITIVE SIGNAL APPLIED TO TERMINAL 2 WILL PRODUCE A DECREASE IN SOUND PRESSURE AT THE SOUND OUTLET.

ELECTRICAL

DC RESISTANCE	63 Ω ±10%	*
IMPEDANCE @ 500 Hz	89 Ω ±15%	*
IMPEDANCE @ 1 kHz	141 Ω ±20%	*
INDUCTANCE @ 500Hz	20 mH ±15%	
CAPACITANCE @ 10 MHz	6 pF ±20%	

TABLE 4.

ISOLATION: THE CASE WILL BE ELECTRICALLY ISOLATED FROM THE COIL CIRCUIT*

MAGNETIC RADIATION

WORST CASE: FIELD WILL BE LESS THAN LEVEL STATED BELOW AT AMPLIFIER CLIPPING (.920 V).

134 dB re 1µA/m

DISTANCE OF 6.3 mm FROM CENTER OF RECEIVER

ANGLE OF 120 DEGREES FROM TUBE

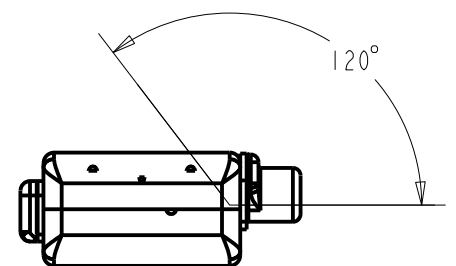

MECHANICAL

PORT LOCATION: 12C

SOLDER TYPE: SAC305

TEMPERATURE

OPERATING: SENSITIVITY WILL NOT VARY MORE THAN +1/-3 dB FROM -17°C TO 63°C

STORAGE: -40°C TO 63°C

RELIABILITY

UNITS WILL SURVIVE ANY OF THE FOLLOWING ACCELERATED LIFE TESTS, REPORT AVAILABLE FROM QA DEPARTMENT

HALT TEST (8 WEEKS, 63°C, 95% RH, 0.83V, 500 Hz SIGNAL)

HIGH TEMPERATURE STORAGE (63°C, 72 HOURS)

LOW TEMPERATURE STORAGE (-40°C, 72 HOURS)

DAMP HEAT CYCLING (ALTERNATE 25°C TO 63°C, 93% RH, 20 CYCLES)

THERMAL SHOCK (-40°C TO 63°C, 5 CYCLES)

SOLDER/DESOLDER CYCLING (5 CYCLES)

SOLDER PAD STRENGTH (STRENGTH > 1.8 LBS.)

STRESS TEST (3.72 Vrms AT 2700 Hz SIGNAL, 1 HOUR)

MECHANICAL SHOCK

LEAK TEST AFTER AGING (NO LEAK AFTER ANY OF THE ABOVE TESTS)

Revision	C.O. #	Implementation Date	RELEASE LEVEL	REVISION
			Active	D
D	C10115023P	10-14-13		
WHEN TEST LIMITS ARE USED TO ESTABLISH INCOMING INSPECTION ACCEPTANCE/REJECTION CRITERIA, CORRELATION OF TEST EQUIPMENT WITH KNOWLES IS ALSO REQUIRED FOR ELIMINATION OF EQUIPMENT AND TEST METHOD VARIATION			DR. BY	DATE
TITLE: RECEIVER PERFORMANCE SPECIFICATION			AB	11-29-05
			HC-23724-000 SHT 2.1	
			CK. BY	DATE
			GJP	12-5-05
			APP. BY	DATE
			GJP	12-5-05

KNOWLES ELECTRONICS
ITASCA, ILLINOIS U.S.A.

Компания «Life Electronics» занимается поставками электронных компонентов импортного и отечественного производства от производителей и со складов крупных дистрибьюторов Европы, Америки и Азии.

С конца 2013 года компания активно расширяет линейку поставок компонентов по направлению коаксиальный кабель, кварцевые генераторы и конденсаторы (керамические, пленочные, электролитические), за счёт заключения дистрибьюторских договоров

Мы предлагаем:

- Конкурентоспособные цены и скидки постоянным клиентам.
- Специальные условия для постоянных клиентов.
- Подбор аналогов.
- Поставку компонентов в любых объемах, удовлетворяющих вашим потребностям.
- Приемлемые сроки поставки, возможна ускоренная поставка.
- Доставку товара в любую точку России и стран СНГ.
- Комплексную поставку.
- Работу по проектам и поставку образцов.
- Формирование склада под заказчика.
- Сертификаты соответствия на поставляемую продукцию (по желанию клиента).
- Тестирование поставляемой продукции.
- Поставку компонентов, требующих военную и космическую приемку.
- Входной контроль качества.
- Наличие сертификата ISO.

В составе нашей компании организован Конструкторский отдел, призванный помогать разработчикам, и инженерам.

Конструкторский отдел помогает осуществить:

- Регистрацию проекта у производителя компонентов.
- Техническую поддержку проекта.
- Защиту от снятия компонента с производства.
- Оценку стоимости проекта по компонентам.
- Изготовление тестовой платы монтаж и пусконаладочные работы.



Тел: +7 (812) 336 43 04 (многоканальный)
Email: org@lifeelectronics.ru