



DT SERIES ELEMENTS WITH LEAD ATTACHMENT

SPECIFICATIONS

- ◆ Piezoelectric film sensor
- ◆ AC Coupled
- ◆ Silver Ink Electrodes
- ◆ Protective Coating over Electrodes
- ◆ Lead Wires Attached with Rivets.

The DT Series of Piezo film sensors elements are rectangular elements of Piezo film with silver ink screen printed electrodes. They are available in a variety of different sizes and thicknesses. Lead attachment is accomplished using a riveted lug going to 12" (300 mm) of 28 AWG wire.

The DT film element produces more than 10 millivolts per micro-strain. The capacitance is proportional to the area and inversely proportional to the thickness of the element.

The DT elements are supplied with a thin protective coating over the active electrode area to prevent oxidation to the top surface of the silver ink.

FEATURES

- ◆ Minimum Impedance: 1 MΩ
- ◆ Preferred Impedance: 10 MΩ and higher
- ◆ Output Voltage: 10 mV to 100V depending on Force and Circuit Impedance
- ◆ Storage Temperature: -40°C to +70°C [-40°F to 60°F]
- ◆ Operating Temperature: 0°C to +70°C [32°F to 160°F]

APPLICATIONS

- ◆ Sensing Direct Contact Force
- ◆ Recording Time of an Event
- ◆ Counting Number of Impact Events
- ◆ Measuring Impact Related Events

TYPICAL PIEZO FILM PROPERTIES

Symbol	Parameter	PVDF	Units
t	Thickness	28, 52	μm
d ₃₁	Piezo Strain Constant	23	(10 ⁻¹²)C/N
d ₃₃		-33	
g ₃₁	Piezo Stress constant	216	(10 ⁻³)Vm/N
g ₃₃		-330	
k ₃₁	Electromechanical Coupling Factor	12%	
k _t		14%	
C	Capacitance	380 for 28μm	pF/cm ² . @ 1KHz
Y	Young's Modulus	2-4	10 ⁹ N/m ²
V ₀	Speed of Sound	2.2	10 ³ m/s in thickness direction

DT SERIES ELEMENTS WITH LEAD ATTACHMENT

DIMENSIONS and PART NUMBERS

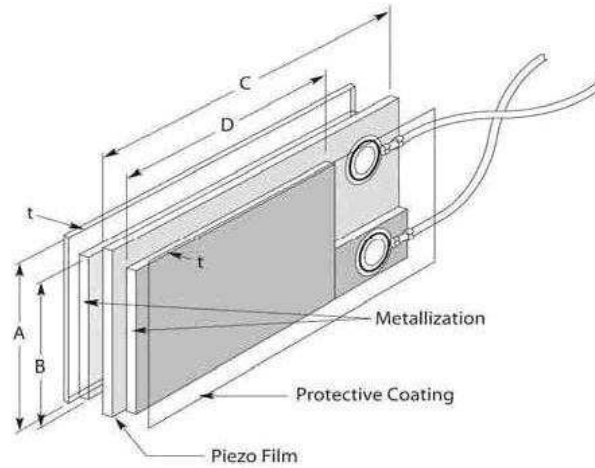

Dimensions in inches (mm)

Model Number	Part Number	Film Thickness	A Film	B Electrode	C Film	D Electrode	Total Thickness (μm)	Cap (nF)
DT1-028K/L w/rivets	1-1002908-0	28 μm	.64 (16)	.484 (12)	1.63 (41)	1.19 (30)	40	1.38
DT1-052K/L w/rivets	2-1002908-0	52 μm	.64 (16)	.484 (12)	1.63 (41)	1.19 (30)	64	.740
DT2-028K/L w/rivets	1-1003744-0	28 μm	.64 (16)	.484 (12)	2.86 (73)	2.42 (62)	40	2.78
DT2-052K/L w/rivets	2-1003744-0	52 μm	.64 (16)	.484 (12)	2.86 (73)	2.42 (62)	64	1.44
DT4-028K/L w/rivets	1-1002150-0	28 μm	.86 (22)	.740 (19)	6.72 (171)	6.72 (171)	40	11.00
DT4-052K/L w/rivets	2-1002150-0	52 μm	.86 (22)	.740 (19)	6.72 (171)	6.72 (171)	64	5.70

NORTH AMERICA

Measurement Specialties, Inc.,
a TE Connectivity Company
Tel: +1-800-522-6752
Email: customercare.dtmtd@te.com

EUROPE

MEAS Deutschland GmbH
a TE Connectivity Company
Tel: +49-800-440-5100
Email: customercare.dtmtd@te.com

ASIA

Measurement Specialties (China), Ltd.,
a TE Connectivity Company
Tel: +86 0400-820-6015
Email: customercare.chdu@te.com

TE.com/sensorsolutions

Measurement Specialties, Inc., a TE Connectivity company.

Measurement Specialties, TE Connectivity, TE Connectivity (logo) and EVERY CONNECTION COUNTS are trademarks. All other logos, products and/or company names referred to herein might be trademarks of their respective owners.

The information given herein, including drawings, illustrations and schematics which are intended for illustration purposes only, is believed to be reliable. However, TE Connectivity makes no warranties as to its accuracy or completeness and disclaims any liability in connection with its use. TE Connectivity's obligations shall only be as set forth in TE Connectivity's Standard Terms and Conditions of Sale for this product and in no case will TE Connectivity be liable for any incidental, indirect or consequential damages arising out of the sale, resale, use or misuse of the product. Users of TE Connectivity products should make their own evaluation to determine the suitability of each such product for the specific application.

© 2015 TE Connectivity Ltd. family of companies All Rights Reserved.

Компания «Life Electronics» занимается поставками электронных компонентов импортного и отечественного производства от производителей и со складов крупных дистрибьюторов Европы, Америки и Азии.

С конца 2013 года компания активно расширяет линейку поставок компонентов по направлению коаксиальный кабель, кварцевые генераторы и конденсаторы (керамические, пленочные, электролитические), за счёт заключения дистрибьюторских договоров

Мы предлагаем:

- Конкуренспособные цены и скидки постоянным клиентам.
- Специальные условия для постоянных клиентов.
- Подбор аналогов.
- Поставку компонентов в любых объемах, удовлетворяющих вашим потребностям.
- Приемлемые сроки поставки, возможна ускоренная поставка.
- Доставку товара в любую точку России и стран СНГ.
- Комплексную поставку.
- Работу по проектам и поставку образцов.
- Формирование склада под заказчика.
- Сертификаты соответствия на поставляемую продукцию (по желанию клиента).
- Тестирование поставляемой продукции.
- Поставку компонентов, требующих военную и космическую приемку.
- Входной контроль качества.
- Наличие сертификата ISO.

В составе нашей компании организован Конструкторский отдел, призванный помогать разработчикам, и инженерам.

Конструкторский отдел помогает осуществить:

- Регистрацию проекта у производителя компонентов.
- Техническую поддержку проекта.
- Защиту от снятия компонента с производства.
- Оценку стоимости проекта по компонентам.
- Изготовление тестовой платы монтаж и пусконаладочные работы.



Тел: +7 (812) 336 43 04 (многоканальный)
Email: org@lifeelectronics.ru