



Released

K-Band Doppler Sensor Module

RF Frequency: 24.05 to 24.25 GHz

Model No. NJR4265R series

Frequency Line-up:	F1: 24.05 to 24.25 GHz / EU
	F2: 24.15 to 24.25 GHz / EU
	F3: 24.075 to 24.175 GHz / US
	J1: 24.05 to 24.25 GHz / JAPAN
Software Version:	C1: Original Release

Specifications
Rev.05e July 11, 2017

© Copyright 2017

New Japan Radio Co., Ltd.
Microwave Division

-Notice of Proprietary Information-
Documents and contents are proprietary to New Japan Radio Co., Ltd.
This publication and its contents may not be reproduced or distributed for any
other purpose without the written permission of New Japan Radio Co., Ltd.

24GHz Microwave Intelligent Motion Sensor for Short Distance, Low Speed Applications

NJR4265R is intelligent motion sensor that is designed for the sensing of short distance low speed movement object of pedestrian etc. The steady sensing of moving object is realized by embedded software. It is suitable for the built-in use of the sensing function to various equipment as all functions are integrated in a small package and it can easily control from PC/MCU by UART interface. Further, stand-alone operation is also possible.

Features:

- Motion sensor using the 24GHz Microwave Doppler
- Antenna, RF circuit, IF amp, MCU and voltage regulator are integrated in a small package (14 x 20.4 x 8.8mm)
- Communication with PC/MCU is available by UART interface and stand-alone operation is also possible
- Signal processing software for the steady sensing
 - Enhancing the signal from movement object and decreasing random noises
 - Decreasing the mutual interference between sensors
 - Identification of direction for movement object (approaching and leaving).
- Low voltage operation and low power consumption
- Sleep mode for reducing power when unnecessary

Applications:

- Various equipment control by human sensing
 - Energy saving management
 - Entrance and exit management
 - Safety and Security

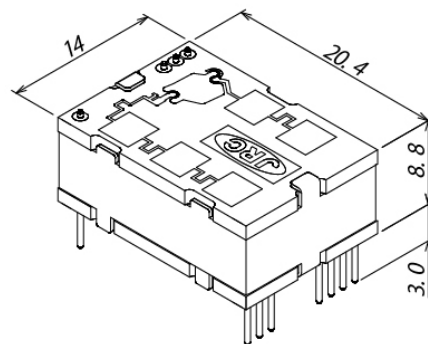

Functional Block diagram:

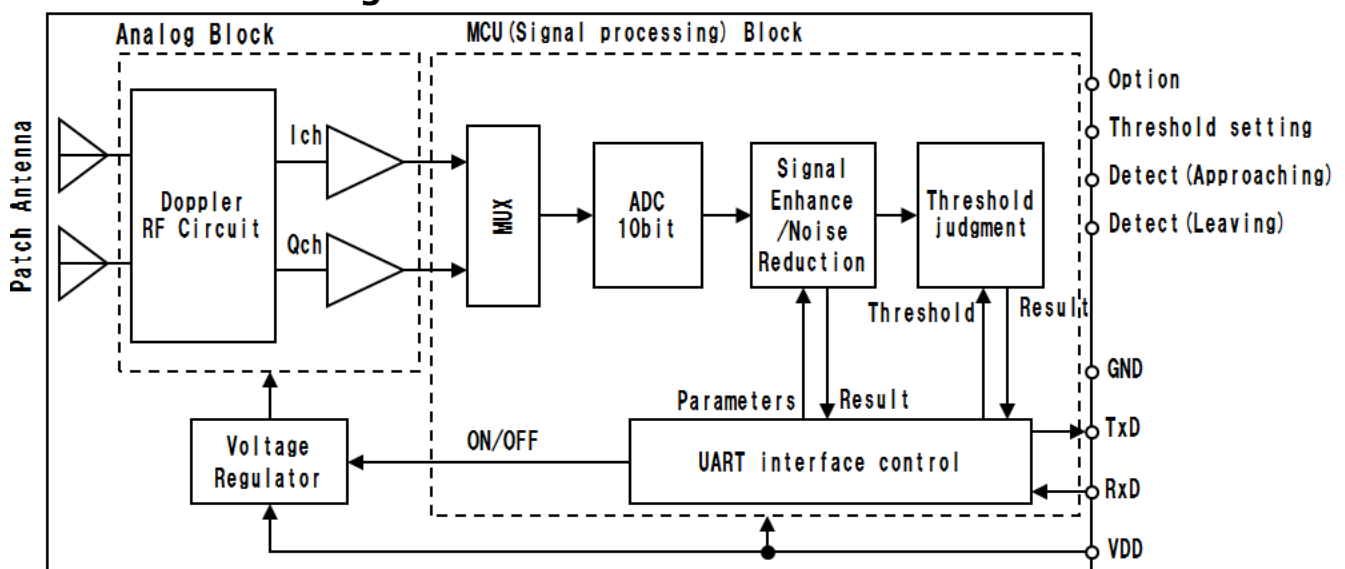

Products Line-up:

- **Model Numbering System**

N J R 4 2 6 5 R **F 1** C 1

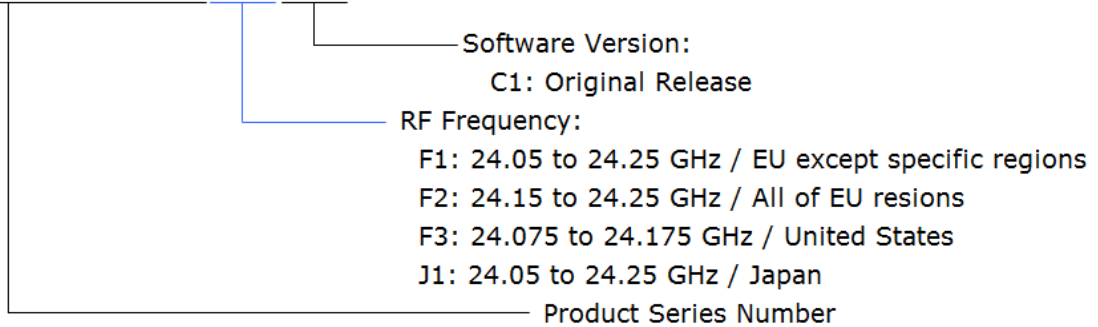

- **Model Number List**

Model No.	RF Frequency	Software Version	Region	Certification
NJR4265RF1C1	24.05 to 24.25 GHz (F1 type)	Original Release	EU except specific regions (UK, France, etc)	EU/EC Radio Equipment Directive (RED) 2014/53/EU (CE Marking)
NJR4265RF2C1	24.15 to 24.25 GHz (F2 type)		All of EU regions	
NJR4265RF3C1 <i>*Note</i>	24.075 to 24.175 GHz (F3 type)		US	FCC Part 15.245
NJR4265RJ1C1	24.075 to 24.175 GHz (J1 type)		JAPAN	MIC Technical Conformity ARIB STD-T73

**Note: The Model of FCC certification (Model No. NJR4265RF3C1) must refer to Appendix of "FCC Statement of NJR4265RF3".*

- **Evaluation Kit**

The evaluation kit is available for NJR4265R series. The contents of the evaluation kit are as follows.

- **Evaluation Kit P/N.: NJR4265J1K**

- **Contents**

1. Sensor Module
2. Evaluation Board (Functions are UART-to-USB convertor and analog threshold setting)
3. GUI Software
4. USB Cable

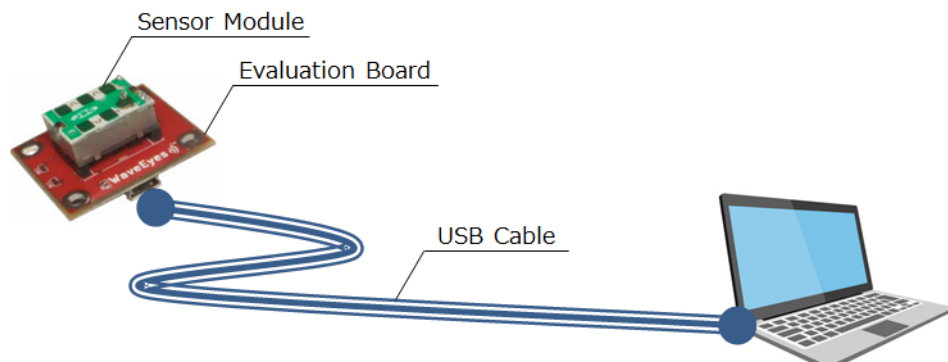

1. Absolute Maximum Rating

ITEM	MIN.	TYP.	MAX.	UNITS	REMARKS
Supply Voltage	0	—	6.5	V	
Operating Temperature	-40	—	+85	°C	
Storage Temperature	-40	—	+85	°C	

2. Electrical Characteristics

Common measure condition Ta= +25 °C

ITEM	MIN.	TYP.	MAX.	UNITS	REMARKS
Power Supply					
Operating Voltage	3.0	3.3/5.0	5.25	V	
Operating Current					
Sensing mode	—	60	—	mA	
Sleep mode	—	4	—	mA	
Sensor RF					
Conformity Standard	<ul style="list-style-type: none"> ● EU Certification: Radio Equipment Directive 2014/53/EU ● FCC Certification: Part 15.245 ● MIC Technical Conformity (Japan): ARIB STD-T73 				
Operating Frequency					
F1 type	24.05	—	24.25	GHz	EU Certification
F2 type	24.15	—	24.25	GHz	
F3 type	24.075	—	24.175	GHz	FCC Certification
J1 type	24.05	—	24.25	GHz	Japan Certification
Frequency Stability (Temp.)	—	+/-0.2	—	MHz/°C	Ta=-20 to +60 °C
Output Power (E.I.R.P.)	8.2	—	13	dBm	
2 nd Harmonics (E.I.R.P.)	—	—	-30	dBm	
Antenna					
-3dB beam width (Horizontal)	—	70	—	deg.	
-3dB beam width (Vertical)	—	54	—	deg.	
Side lobe suppression (Horizontal)	—	—	—	dB	No Side lobe
Side lobe suppression (Vertical)	—	—	—	dB	No Side lobe

Typical Radiation Pattern

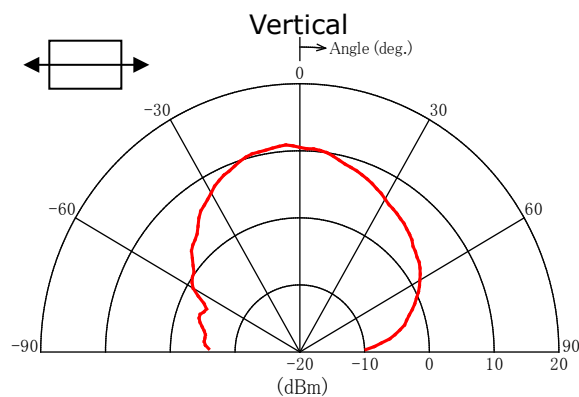
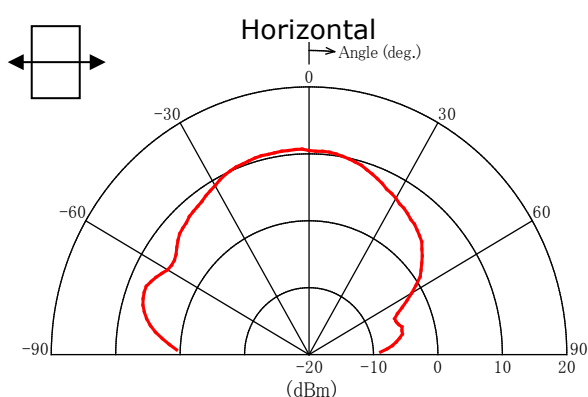

3. Environmental characteristics

ITEM	SPECIFICATION
Operation Temperature	-20 to +60 °C
Storage Temperature	-40 to +80 °C
Humidity	0 to 95 % @+30 °C
Vibration	49.03 m/s ² (5 G), 30 to 50 Hz, 10 minutes, XYZ direction
Shock	196.13 m/s ² (20 G), Half sine, 11 ms, XYZ direction, 3 times

4. Sensing Performance

Common measure condition $T_a = +25\text{ }^\circ\text{C}$

ITEM	PERFORMANCE	UNITS	REMARKS
Speed Range of Target	0.25 to 1.0	m/s	
Maximum Distance in Front	10	m	
Detectable Angle	+/-35	deg.	

*Note) This is not the specification to guarantee the performance of this product. As for the specification of the product, the electric characteristic standard is applied. Sensing performance shown here is an example of the result of being likely to obtain it when this product is used on the following conditions. Actual sensing performance would be greatly different in each environment used. Please do enough confirmation in the environment actually used.

Definition of Sensing Performance

- * Speed Range of Target: The range of the speed that the detection distance become 70% of the detection distance of 0.5 m/s
- * Maximum Distance in Front: Detectable distance that can be detected in front of sensor when a threshold value set to [999] or when VDD is added to a threshold setting terminal
- * Detectable Angle: Angle where detection distance becomes 70% of the front

Measurement condition of detection performance

- * Temperature: $T_a = +25\text{ }^\circ\text{C}$
- * Target of Measurement: An adult of 170cm/70kg approaching at the rate of 0.5m/s from the front of sensor
- * Installation of the Sensor: The sensor is installed as the antennas horizontal horizontally in a height of 1 m from the ground.



5. Signal processing for the steady sensing of moving object

This product is embedding software for the steady sensing of moving object. It is enhance the signal from movement object of pedestrian etc. and is reduce random noise and sudden signal which caused an incorrect detection by using the signal from IQ mixer, namely **Environmental Noise Reduction**.

The following effects are expectable.

- Reduction of false detection by random movement such as the shakes of plant by wind or the noise of rain etc.
- Reduction of the false detection by sudden movement such as the insect etc. which cross just before a sensor
- Steady detection of movement objects such as pedestrian under the environment where the above-mentioned noise exists.
- Reduction of the mutual interference of sensors
- Identification of direction of movement (approach and leaving)

*Note) This signal processing function assumes the following noises are reduced, and pedestrian's movement is emphasized. However, it is likely to become a counter productivity for a signal outside assumption.

6. Interface

6.1. Pin Assignment

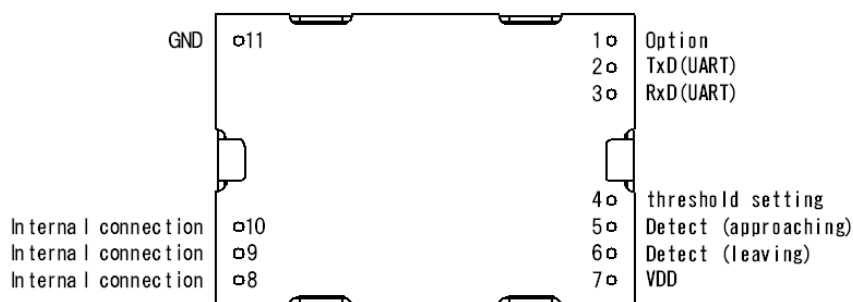

Pin diagram (Bottom View)

#	NAME	I/O	DESCRIPTION
1	Option	—	Option Pin Option pin is not assigned at NJR4265R. Keep it in electrically open state
2	TxD (UART)	O	UART TxD
3	RxD (UART)	I	UART RxD
4	Threshold Setting	I	Analog threshold voltage (V_{TH}) Available to set by the voltage applied to this pin. Threshold of detection distance = $V_{TH} / V_{DD} \times 10\text{ m}$ *Note1
5	Detect (approaching)	O	Output for approaching detection *Note2 H: Detect / L: No detect
6	Detect (leaving)	O	Output for leaving detection *Note2 H: Detect / L: No detect
7	VDD	I	Power Supply Input (V_{DD}): 3.0 to 5.25 V
8	—	—	Internal connection *Note3 DO NOT connect any signal lines including GND.
9	—	—	
10	—	—	
11	GND	—	GND Pin

*Note1) Detection distance assumes the case that an adult of 170cm/70kg approaches at the rate of 0.5m/s from the front.

*Note2) Pin 5 or 6 is changed to H level respectively when the movements of approaching or leaving is detected. (Output current < 5mA)

*Note3) Pin 8, 9 and 10 are used for internal connection. Those must be electrically open independently. These pins must use the via holes of an independent pad when the sensor install on a PCB.
Do not connect also between these terminals too.

6.2. Asynchronous Serial Data Bus (UART) Interface

NJR4265R is able to control of sensor mode, set of threshold level, acquisition of detection result and acquisition of various information of sensor states from PC or MCU, etc. by using UART Interface.

ITEM	FORMAT	UNITS	REMARKS
Signal Level	CMOS	—	Internally pulled-up by 10 Kohms
Communication Parameters			
Baud Rates	9600	bps	
Data Bits	8	bits	
Stop Bits	1	bits	
Parity	odd	—	
Handshake	non	—	
Byte Order	LSB	—	

7. Operational mode

MODE	DESCRIPTION
Power ON / Reset	CPU Reset.
Initialization Mode	Initialize and wait until sensor is stabilized. Notice command is sent out after the completion of initialization.
Detection Mode	Detection command is sent when following changes arise in the state of the sensor detection. 1. detect approaching object 2. detect leaving object 3. state change from detection to no-detection
Sleep Mode	Shutdown of all analog circuit for reducing the current. When returning to detection mode, about one second needs for stabilization of the sensor.

*Note) When the watch dog timer overflows, it is reset from any mode

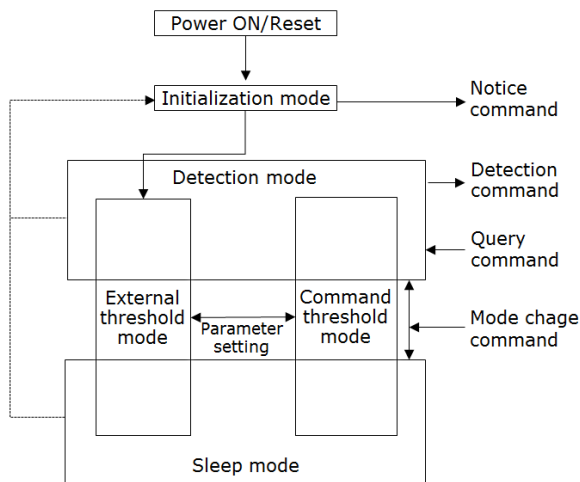

State Transition Diagram

		Event					
		Power ON	Self test	Mode change command (Sleep)	Mode change command (Detect)	Reset command	Watch dog timer
State	Reset	Initialization mode	Setting disable	Setting disable	Setting disable	Setting disable	Setting disable
	Initialization mode	Setting disable	Detection mode	ignore	ignore	ignore	Reset
	Detection mode	Setting disable	Setting disable	Sleep mode	ignore	Reset	Reset
	Sleep mode	Setting disable	Setting disable	ignore	Detection mode	Reset	Reset

State Transition Table

- The default detection mode at the Power-on or CPU reset is analog threshold mode. It is possible to change to the command threshold mode by sending parameter setting commands. (@SP, @SM and @SC)
- The @SA command is effective when changing from the command threshold to an analog threshold mode.
- When mode is changed to sleep mode or is resumed from sleep mode, the threshold mode is preserved. Moreover, the change of the threshold mode in sleep mode is also possible.

8. Communication command

8.1. Outline

COMMAND TYPE	DIRECTION	DESCRIPTION	EFFECTIVE MODE
Detection	Sensor to Host	Sending from sensor when movement is detected	Detection mode
Mode Change	Host to Sensor	Change the sensor mode	Detection mode Sleep mode
Parameter Setting	Host to Sensor	Setting and change of threshold parameters	
Query	Sensor to Host Host to Sensor	Reading of state of sensor (mode , parameters)	
Reset	Host to Sensor	Reset of sensor	
Start Notification	Sensor to Host	Sending from sensor when initialization is completed	Initialization mode
Error Response	Sensor to Host	Sending from sensor when error occurs	All mode

8.2. Communication Command List

Both Sensor-to-Host (S-to-H) and Host-to-sensor (H-to-S) use the following formats.

@ XXX xx <CR><LF>

- @:** Command header
- XXX:** Command characters, alphabet 1-3 characters. (Capital letter and small letter are Distinguished.)
- xx:** Command/configuration parameters (numerical value or alphabet one character or "?".)
- <CR><LF>:** Delimiter (CR+LF)

CONTENTS/EFFECTS	XXX	DIRECTION	FORMAT	REMARKS
Detection Commands				
Detected Approaching movement	C	S-to-H	@C<CR><LF>	
Detected Leaving movement	L	S-to-H	@L<CR><LF>	
Becomes undetected from detected	N	S-to-H	@N<CR><LF>	
Mode Change Commands				
Change to Detection mode	T	H-to-S	@T<CR><LF>	
Change to Sleep mode	U	H-to-S	@U<CR><LF>	
Parameter Setting Commands				
Setting an Approaching threshold	SP	H-to-S	@SPxxx<CR><LF>	
Setting a Leaving threshold	SM	H-to-S	@SMxxx<CR><LF>	
Change to Analog threshold mode	SA	H-to-S	@SA<CR><LF>	
Change to Command threshold mode	SC	H-to-S	@SC<CR><LF>	
Query Commands				
Acquire the present detection	Q1	H-to-S	@Q1?<CR><LF>	
Response of present detection		S-to-H	@C<CR><LF>	Approaching
			@L<CR><LF>	Leaving
			@N<CR><LF>	No detection
Acquire the present mode	Q2	H-to-S	@Q2?<CR><LF>	
Response of present mode		S-to-H	@T<CR><LF>	Detection mode
			@U<CR><LF>	Sleep mode

CONTENTS/EFFECTS	XXX	DIRECTION	FORMAT	REMARKS
Acquire the present threshold mode	Q6	H-to-S	@Q6?<CR><LF>	
Response of present threshold mode		S-to-H	@SA<CR><LF>	Analog threshold
			@SC<CR><LF>	Command threshold
Acquire the Approaching threshold	SP	H-to-S	@SP?<CR><LF>	
Response of Approaching threshold		S-to-H	@SPxxx<CR><LF>	*Note1
Acquire the Leaving threshold	SM	H-to-S	@SM?<CR><LF>	
Response of Leaving threshold		S-to-H	@SMxxx<CR><LF>	*Note1
Acquire the Analog threshold	SV	H-to-S	@SV?<CR><LF>	
Response Analog threshold		S-to-H	@SVxxxx<CR><LF>	Value of ADC
Acquire the software version	V	H-to-S	@V?<CR><LF>	
Response of software version		S-to-H	@Vx.xx<CR><LF>	x.xx: Version
Reset Command, Start Notification Command				
Reset Command	R	H-to-S	@R<CR><LF>	
Start Notification	W	S-to-H	@W<CR><LF>	
Error Response Commands				
Notification of UART framing error	EF	S-to-H	@EF<CR><LF>	
Notification of UART parity error	EP	S-to-H	@EP<CR><LF>	
Notification of Communication error	ER	S-to-H	@EP<CR><LF>	
Notification of Self-test	ES	S-to-H	@ER<CR><LF>	
Notification of watch dog timer error	EW	S-to-H	@EW<CR><LF>	

*Note1) Capable threshold setting range is Integer 1-999.

The relation between the threshold value and the detection distance (*Note2) can be shown by the following expressions:

$Da = SP/100$, [Da] is approaching detection distance (units: m)

$DI = SM/100$, [DI] is leaving detection distance (units: m)

*Note2) Detection distance assumes the case that an adult of 170cm/70kg approaches at the rate of 0.5m/s from the front.

NJR4265R series

9. Drawing

9.1. Outline

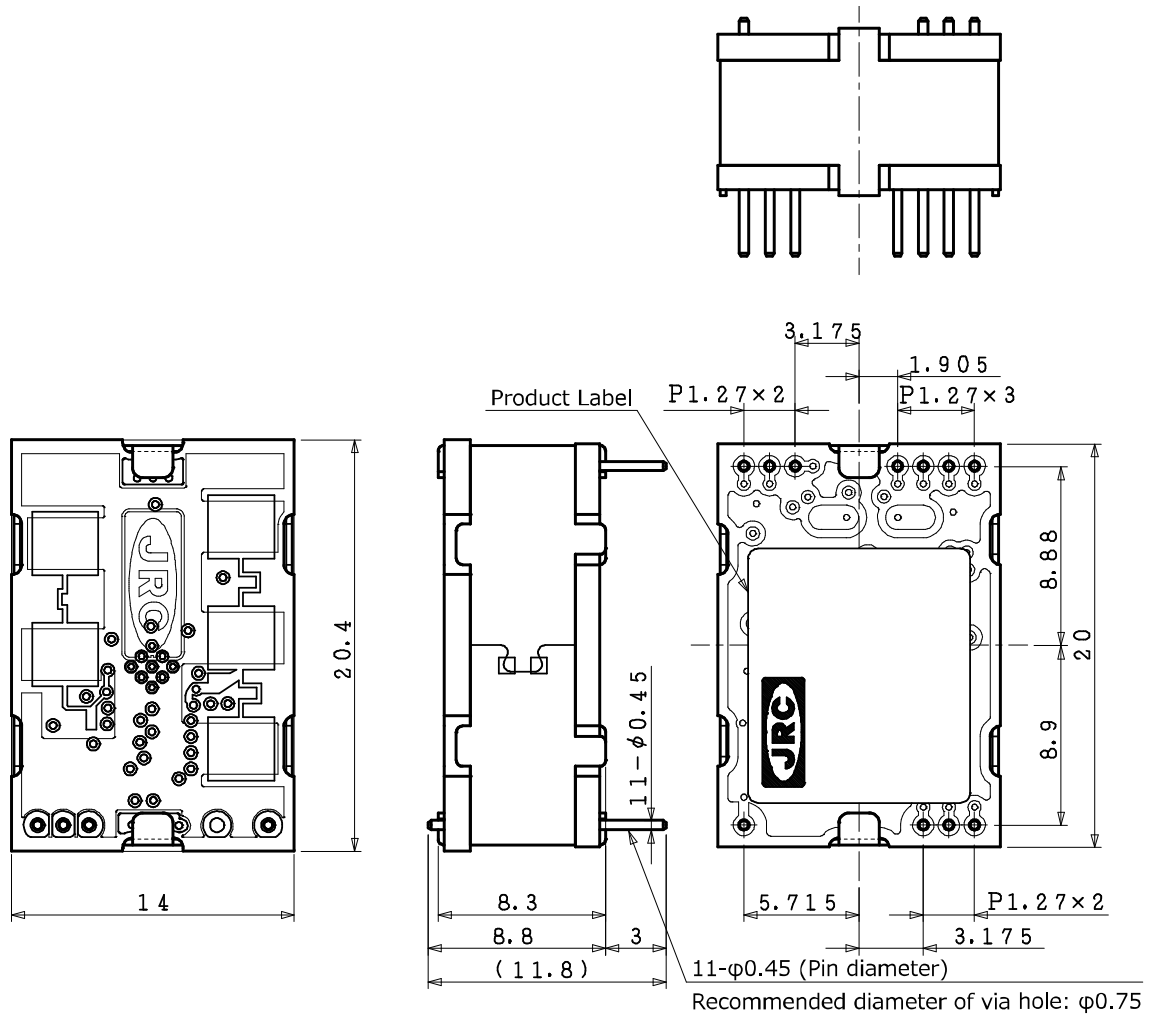

unit: mm
tolerance: +/-0.5

9.2. Label

NJR4265RF1C1	NJR4265RF2C1	NJR4265RF3C1	NJR4265RJ1C1
<p>NJR4265RF1C1 A00001A New Japan Radio Co., Ltd.</p>	<p>NJR4265RF2C1 A00001A New Japan Radio Co., Ltd.</p>	<p>JRC RoHS NJR4265RF3C1 A00001A FCC ID:2ACUJR4265</p>	<p>NJR4265R...J1 A000001A 001-A06676 RoHS 新日本無線株式会社</p>

10. Package

Standard Package

Packing Quantity: 500 pieces per shipping box

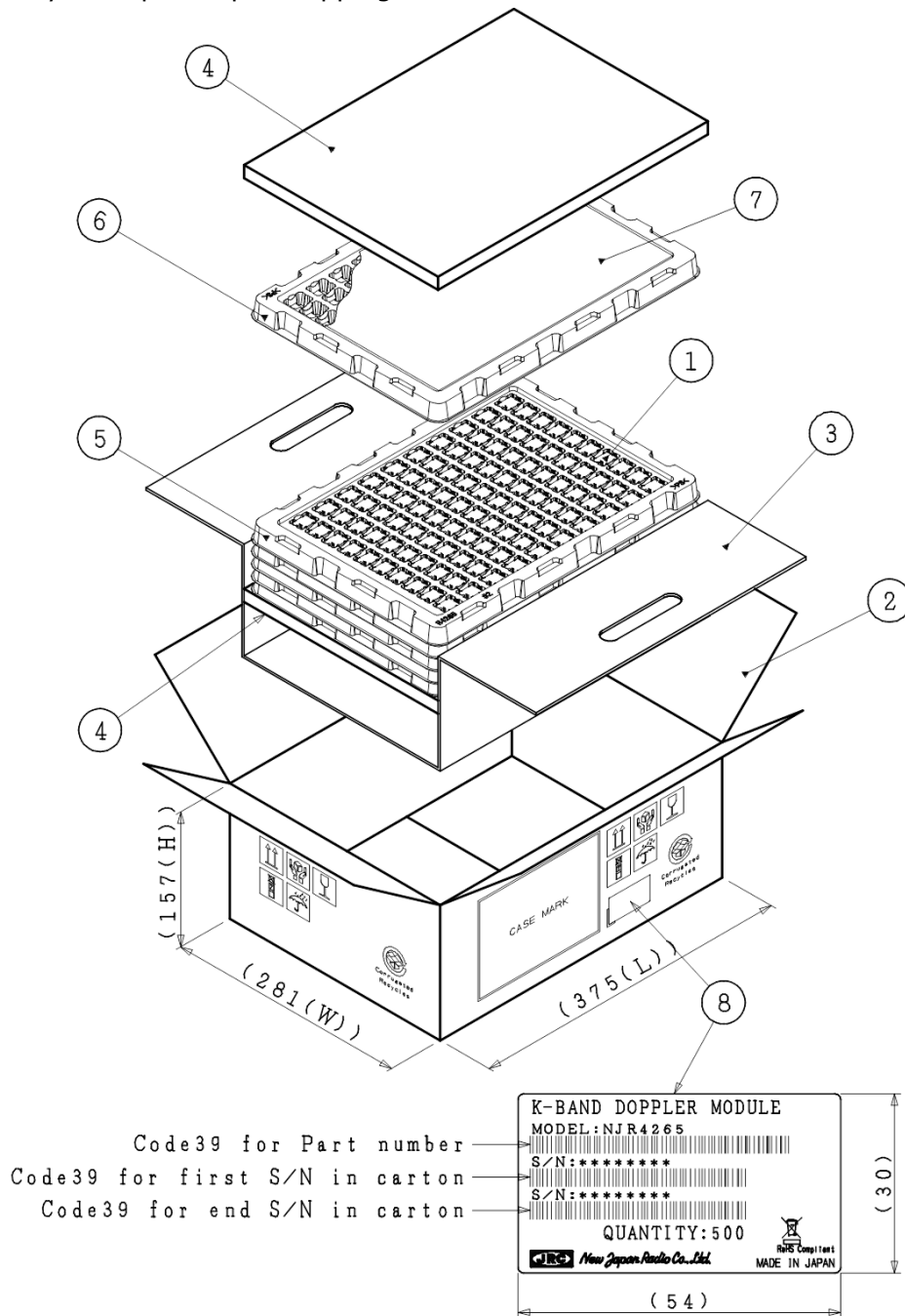

- ①NJR4265R 24GHz Doppler module
- ②Outer packaging:double wall corrugated fiberboard
- ③Inner packaging:single wall corrugated fiberboard
- ④Package cushioning:polyethylene foam
- ⑤Tray for modules (100 pcs×5 trays):conductive polystyrene
- ⑥Dummy tray:conductive polystyrene.
- ⑦Package label.

11. Reference Circuit

11.1. Example of connecting with MCU



11.2. Example of using it by stand-alone



12. Recommendation Mounting Conditions

12.1. Footprint dimensions

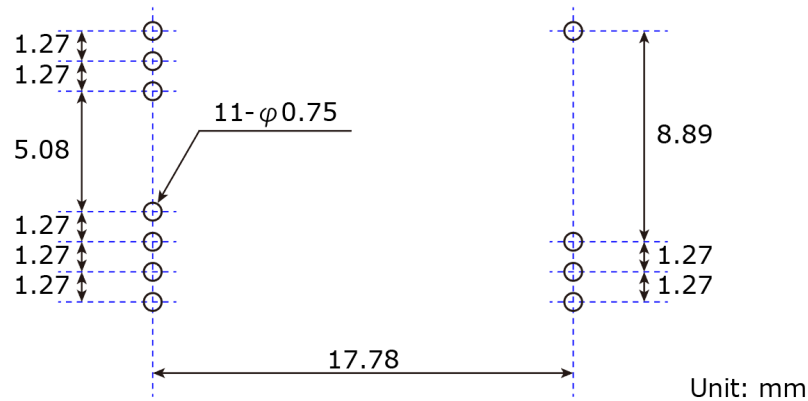

*Note) In actual design, please optimize in accordance with the situation of your board design and soldering condition.

12.2. Soldering conditions

- Soldering way: Solder iron *Note
- Solder iron temperature: 350 °C or less
- Mounting time: 3 second or less per pin

*Note) The soldering iron to be used must be grounded via a resistance of about 1 M Ω .



Caution

1. NJRC strives to produce reliable and high quality microwave components. NJRC's microwave components are intended for specific applications and require proper maintenance and handling. To enhance the performance and service of NJRC's microwave components, the devices, machinery or equipment into which they are integrated should undergo preventative maintenance and inspection at regularly scheduled intervals. Failure to properly maintain equipment and machinery incorporating these products can result in catastrophic system failures.
2. To ensure the highest levels of reliability, NJRC products must always be properly handled. The introduction of external contaminants (e.g. dust, oil or cosmetics) can result in failures of microwave components.
3. NJRC offers a variety of microwave components intended for particular applications. It is important that you select the proper component for your intended application. You may contact NJRC's sales office or sales representatives, if you are uncertain about the products listed in the catalog and the specification sheets.
4. Special care is required in designing devices, machinery or equipment, which demand high levels of reliability. This is particularly important when designing critical components or systems whose foreseeable failure can result in situations that could adversely affect health or safety. In designing such critical devices, equipment or machinery, careful consideration should be given to, amongst other things, their safety design, fail-safe design, back-up and redundancy systems, and diffusion design.
5. The products listed in the catalog and specification sheets may not be appropriate for use in certain equipment where reliability is critical or where the products may be subjected to extreme conditions. You should consult our sales office or sales representatives before using the products in any of the following types of equipment.
 - * Aerospace Equipment
 - * Equipment Used in the Deep Sea
 - * Power Generator Control Equipment (nuclear, steam, hydraulic)
 - * Life Maintenance Medical Equipment
 - * Fire Alarm/Intruder Detector
 - * Vehicle Control Equipment (automobile, airplane, railroad, ship, etc.)
 - * Various Safety Equipment
6. NJRC's products have been designed and tested to function within controlled environmental conditions. Do not use products under conditions that deviate from methods or applications specified in the catalog and specification sheets. Failure to employ NJRC's products in the proper applications can lead to deterioration, destruction or failure of the products. NJRC shall not be responsible for any bodily injury, fires or accidents, property damage or any consequential damages resulting from the misuse or misapplication of its products. PRODUCTS ARE SOLD WITHOUT WARRANTY OF ANY OF KIND, EITHER EXPRESS OR IMPLIED, INCLUDING BUT NOT LIMITED TO ANY IMPLIED WARRANTY OF MERCHANTABILITY OR FITNESS FOR A PARTICULAR PURPOSE.
7. The product specifications and descriptions listed in the catalog and specification sheets are subject to change at any time, without notice.

Responsible party:

New Japan Radio Co.,Ltd.
1-1, Fukuoka 2-chome Fujimino city Saitama Japan
Tel: +81-49-278-1271, Fax: +81-49-278-1234

This device complies with Part 15 of the FCC rules. Operation is a subject to the following two conditions:

- (1) This device may not cause harmful interference.
- (2) This device must accept any interference received, including interference that may cause undesired operation.

Caution

DC power supply for each module should be conformed to the electrical specifications as described in this section. **A host in which a module is integrated should provide stable DC power through suitable regulator circuit to the module.**

NOTE:

Changes or modifications to the device not expressly approved by the party responsible for compliance could void the user's authority to operate the equipment(s).

This equipment has been tested and found to comply with the limits for a Class B digital device, pursuant to part 15 of the FCC Rules. These limits are designed to provide reasonable protection against harmful interference in a residential installation. This equipment generates, uses and can radiate radio frequency energy and, if not installed and used in accordance with the instructions, may cause harmful interference to radio communications. However, there is no guarantee that interference will not occur in a particular installation. If this equipment does cause harmful interference to radio or television reception, which can be determined by turning the equipment off and on, the user is encouraged to try to correct the interference by one or more of the following measures:

- Reorient or relocate the receiving antenna.
- Increase the separation between the equipment and receiver.
- Connect the equipment into an outlet on a circuit different from that to which the receiver is connected.
- Consult the dealer or an experienced radio/TV technician for help.

The equipment complies with radio frequency exposure limits set forth by the FCC for an uncontrolled environment.

The device must not be co-located or operating in conjunction with any other antenna or transmitter.

Appendix)

WARNING:

The FCC regulations provide that changes or modifications not expressly approved by the party responsible for compliance could void the user's authority to operate the equipment.

Limitation for use of the modules:

When the module is installed in a host product, the module shall be connected directly to a PCB of the host product. It shall NOT be extended by any cable. DC power supply for each module must strictly be conformed to each electrical specification as described in the section 1 of this document.

Manual and Product Labeling information to the End User:

End user manual must include all required regulatory information and/or warning as show in this manual.

OEM Integrator must indicate "**Contain FCC ID: 2ACUJR4265**" at the outside of a host product such as label when the module is installed in the host product.

The following statement from FCC §15.19(a)(3) is required on the label of the host equipment.

This device complies with Part 15 of the FCC Rules. Operation is subject to the following two conditions:

- (1) this device may not cause harmful interference, and
- (2) this device must accept any interference received, including interference that may cause undesired operation.

OEM Integrator may be sure that the End user manual may not contain any information about the way to install or remove the modules from the host product.

APPLICABLE MODEL:

This FCC Statement is valid only for the following model number:

NJR4265RF3C1

Компания «Life Electronics» занимается поставками электронных компонентов импортного и отечественного производства от производителей и со складов крупных дистрибьюторов Европы, Америки и Азии.

С конца 2013 года компания активно расширяет линейку поставок компонентов по направлению коаксиальный кабель, кварцевые генераторы и конденсаторы (керамические, пленочные, электролитические), за счёт заключения дистрибьюторских договоров

Мы предлагаем:

- Конкурентоспособные цены и скидки постоянным клиентам.
- Специальные условия для постоянных клиентов.
- Подбор аналогов.
- Поставку компонентов в любых объемах, удовлетворяющих вашим потребностям.
- Приемлемые сроки поставки, возможна ускоренная поставка.
- Доставку товара в любую точку России и стран СНГ.
- Комплексную поставку.
- Работу по проектам и поставку образцов.
- Формирование склада под заказчика.
- Сертификаты соответствия на поставляемую продукцию (по желанию клиента).
- Тестирование поставляемой продукции.
- Поставку компонентов, требующих военную и космическую приемку.
- Входной контроль качества.
- Наличие сертификата ISO.

В составе нашей компании организован Конструкторский отдел, призванный помогать разработчикам, и инженерам.

Конструкторский отдел помогает осуществить:

- Регистрацию проекта у производителя компонентов.
- Техническую поддержку проекта.
- Защиту от снятия компонента с производства.
- Оценку стоимости проекта по компонентам.
- Изготовление тестовой платы монтаж и пусконаладочные работы.



Тел: +7 (812) 336 43 04 (многоканальный)

Email: org@lifeelectronics.ru