

## GENERAL DESCRIPTION

The XRP7664 is a synchronous current-mode PWM step down (buck) regulator capable of a constant output current up to 2Amps. A wide 4.75V to 18V input voltage range allows for single supply operations from industry standard 5V and 12V power rails.

With a 340kHz constant operating frequency and integrated high and low side 120mΩ/110mΩ MOSFETs, the XRP7664 reduces the overall component count and solution footprint. Current-mode control provides fast transient response and cycle-by-cycle current limit. An adjustable soft-start prevents inrush current at turn-on, and in shutdown mode the supply current drops to 0.1uA.

Built-in output over voltage (open load), over temperature, cycle-by-cycle over current and under voltage lockout (UVLO) protections insure safe operations under abnormal operating conditions.

The XRP7664 is a pin and function compatible device to MP1482.

The XRP7664 is offered in a RoHS compliant, "green"/halogen free 8-pin SOIC package.

## APPLICATIONS

- **Distributed Power Architectures**
- **Point of Load Converters**
- **Audio-Video Equipments**
- **Medical & Industrial Equipments**

## FEATURES

- **Pin/Function Compatible to MP1482**
- **2A Continuous Output Current**
- **4.75V to 18V Wide Input Voltage**
- **PWM Current Mode Control**
  - 340kHz Constant Operations
  - Up to 93% Efficiency
- **Adjustable Output Voltage**
  - 0.925V to 16V Range
  - 3% Accuracy
- **Programmable Soft-Start and Enable Function**
- **Built-in Thermal, Over Current, UVLO and Output Over Voltage Protections**
- **RoHS Compliant, "Green"/Halogen Free 8-Pin SOIC Package**

## TYPICAL APPLICATION DIAGRAM

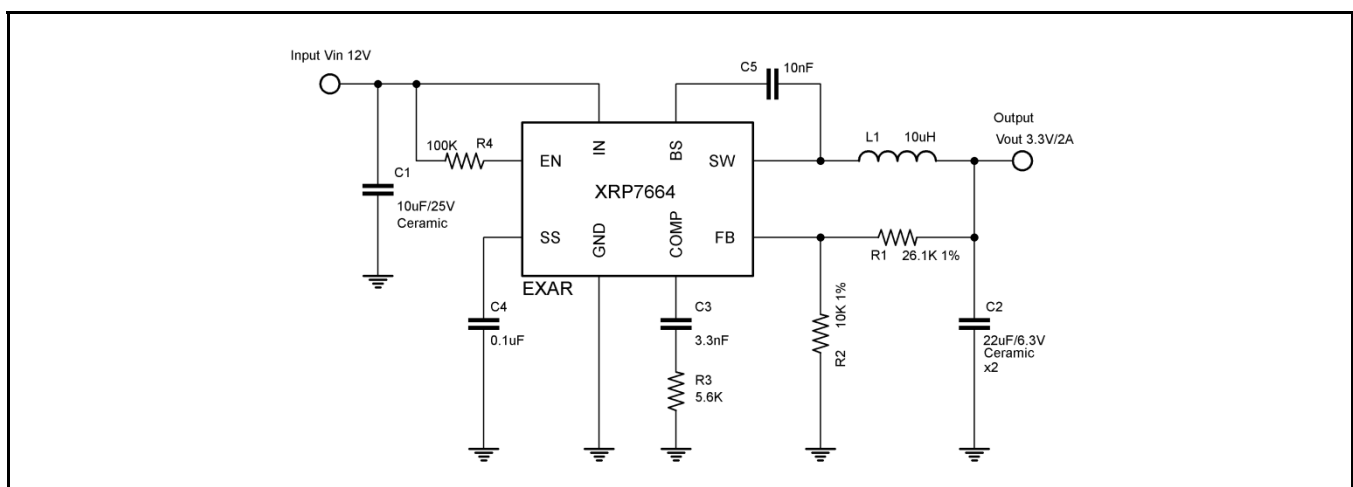

Fig. 1: XRP7664 Application Diagram



**ABSOLUTE MAXIMUM RATINGS**

These are stress ratings only and functional operation of the device at these ratings or any other above those indicated in the operation sections of the specifications below is not implied. Exposure to absolute maximum rating conditions for extended periods of time may affect reliability.

Supply Voltage  $V_{IN}$  ..... -0.3V to 20V  
 Switch Node Voltage  $V_{SW}$  ..... 21V  
 Boost Voltage  $V_{BS}$  ..... -0.3 to  $V_{SW}+6V$   
 Enable Voltage  $V_{EN}$ ..... -0.3 to  $V_{IN}$   
 All Other Pins ..... -0.3 to +6V  
 Junction Temperature ..... 150°C  
 Storage Temperature ..... -65°C to 150°C  
 Lead Temperature (Soldering, 10 sec) ..... 260°C  
 ESD Rating (HBM - Human Body Model) ..... 2kV  
 ESD Rating (MM - Machine Model) .....200V  
 Moisture Sensitivity Level (MSL) ..... 3

**OPERATING RATINGS**

Input Voltage  $V_{IN}$  ..... 4.75V to 18V  
 Ambient Operating Temperature ..... -40°C to 85°C  
 Maximum Output Current..... 2A min  
 Thermal Resistance  $\theta_{JA}$  .....105°C/W

**ELECTRICAL SPECIFICATIONS**

Specifications are for an Operating Ambient Temperature of  $T_A = 25^\circ\text{C}$  only; limits applying over the full Ambient Operating Temperature range are denoted by a “•”. Minimum and Maximum limits are guaranteed through test, design, or statistical correlation. Typical values represent the most likely parametric norm at  $T_A = 25^\circ\text{C}$ , and are provided for reference purposes only. Unless otherwise indicated,  $V_{IN} = V_{EN} = 12V$ ,  $V_{OUT}=3.3V$ .

Parameter	Min.	Typ.	Max.	Units	Conditions
Shutdown Supply Current		0.1	10	$\mu\text{A}$	$V_{EN}=0V$
Quiescent Current		1.0	1.2	mA	$V_{EN}=2V, V_{FB}=1V$
Feedback Voltage $V_{FB}$	0.900	0.925	0.950	V	•
Feedback Overvoltage Threshold		1.1		V	
Error Amplifier Voltage Gain $A_{EA}$ (Note 1)		400		V/V	
Error Amplifier Transconductance $G_{EA}$		800		$\mu\text{A}/V$	
High-Side switch On Resistance $R_{DS(ON)H}$ (Note 2)		120		m $\Omega$	$I_{SW}=0.2A\&0.7A$
Low-Side switch On Resistance $R_{DS(ON)L}$ (Note 2)		110		m $\Omega$	$I_{SW}=-0.2A\&-0.7A$
High-Side switch Leakage Current		0.1	10	$\mu\text{A}$	$V_{IN}=18V, V_{EN}=0V, V_{SW}=0V$
High-Side Switch Current Limit	2.7	3.5	4.3	A	
Low-Side Switch Current Limit		1.4		A	From Drain to Source
COMP to Current Sense Transconductance $G_{CS}$		3.5		A/V	
Oscillator Frequency $F_{OSC1}$	300	340	380	kHz	
Short Circuit Oscillator Frequency $F_{OSC2}$		90		kHz	
Maximum Duty Cycle $D_{MAX}$		90		%	$V_{FB}=0.85V$
Minimum Duty Cycle $D_{MIN}$			0	%	$V_{FB}=1V$
EN Threshold $V_{ENH}$	1.5			V	
EN Threshold $V_{ENL}$			0.5		
UVLO Threshold	3.65	4.00	4.45	V	$V_{IN}$ Rising
UVLO Hysteresis		0.30		V	
Soft-start Current		6		$\mu\text{A}$	
Soft-start Time (Note 1)		10		ms	$C_{SS}=0.1\mu\text{F}, I_{OUT}=500\text{mA}$

Parameter	Min.	Typ.	Max.	Units	Conditions
Thermal Shutdown (Note 1)		160		°C	
Thermal Shutdown Hysteresis (Note 1)		30		°C	
Feedback Bias Current	-0.1		0.1	µA	V <sub>FB</sub> =1V

Note 1: Guaranteed by design.

Note 2:  $R_{DS(on)} = (V_{SW1} - V_{SW2}) / (I_{SW1} - I_{SW2})$

**BLOCK DIAGRAM**

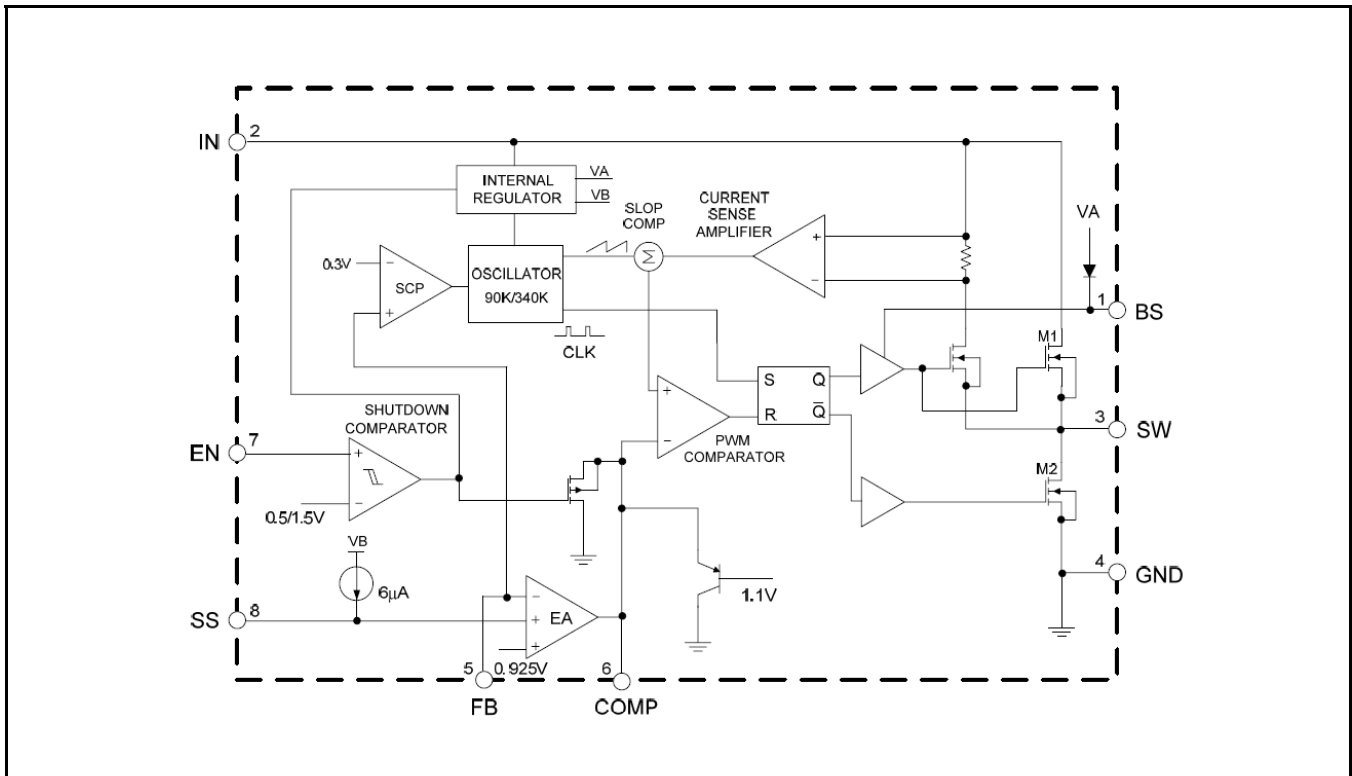

Fig. 2: XRP7664 Block Diagram

**PIN ASSIGNMENT**

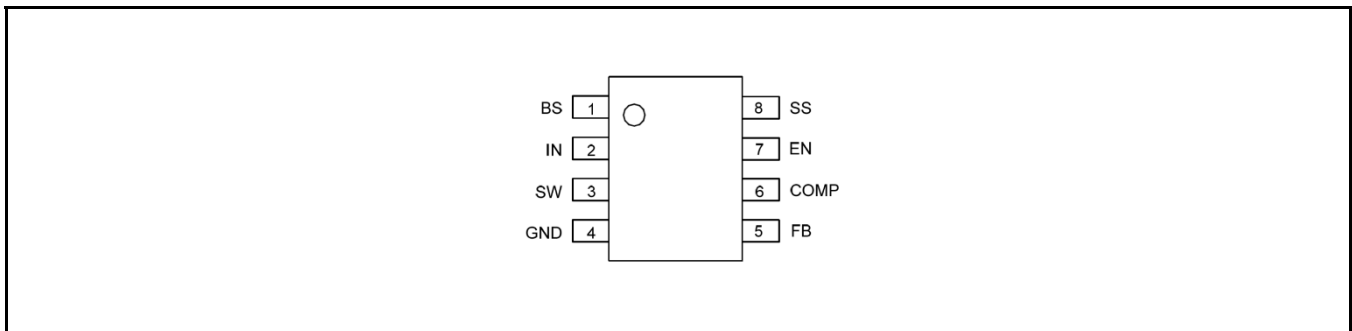

Fig. 3: XRP7664 Pin Assignment (SOIC-8)

**PIN DESCRIPTION**

Name	Pin Number	Description
BS	1	Bootstrap pin. Connect a 0.01 $\mu$ F or greater bootstrap capacitor between the BS pin and the SW pin. The voltage across the bootstrap capacitor drives the internal high-side power MOSFET.
IN	2	Power input pin. A capacitor should be connected between the IN pin and GND pin to keep the input voltage constant.
SW	3	Power switch output pin. This pin is connected to the inductor and the bootstrap capacitor.
GND	4	Ground signal pin.
FB	5	Feedback pin. An external resistor divider connected to FB programs the output voltage. If the feedback pin exceeds 1.1V the over-voltage protection will trigger. If the feedback voltage drops below 0.3V the oscillator frequency is lowered to achieve short-circuit protection.
COMP	6	Compensation pin. This is the output of transconductance error amplifier and the input to the current comparator. It is used to compensate the control loop. Connect an RC network from this pin to GND.
EN	7	Control input pin. Forcing this pin above 1.5V enables the IC. Forcing this pin below 0.5V shuts down the IC. When the IC is in shutdown mode all functions are disabled to decrease the supply current below 1 $\mu$ A.
SS	8	Soft-start control input pin. Connect a capacitor from SS to GND to set the soft-start period. A 0.1 $\mu$ F capacitor sets the soft start period to 10ms. To disable the soft-start feature, leave SS unconnected.

**ORDERING INFORMATION**

Part Number	Temperature Range	Marking	Package	Packing Quantity	Note 1	Note 2
XRP7664IDTR-F	-40°C ≤ T <sub>A</sub> ≤ +85°C	XRP7664I YYWWF X	SOIC-8	2.5K/Tape & Reel	RoHS Compliant Halogen Free	
XRP7664EVB	XRP7664 Evaluation Board					

“YY” = Year – “WW” = Work Week – “X” = Lot Number; when applicable.

**TYPICAL PERFORMANCE CHARACTERISTICS**

All data taken at  $V_{IN} = 12V$ ,  $V_{OUT}=3.3V$ ,  $T_J = T_A = 25^\circ C$ , unless otherwise specified - Schematic and BOM from Application Information section of this datasheet.

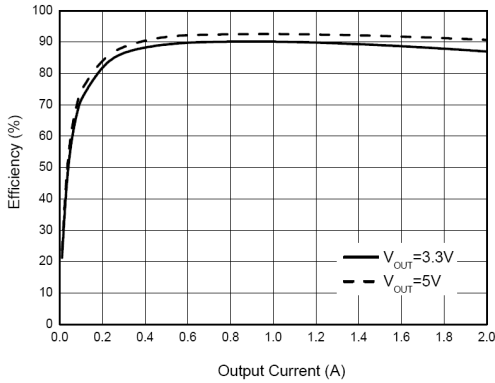

Fig. 4: Efficiency versus output current

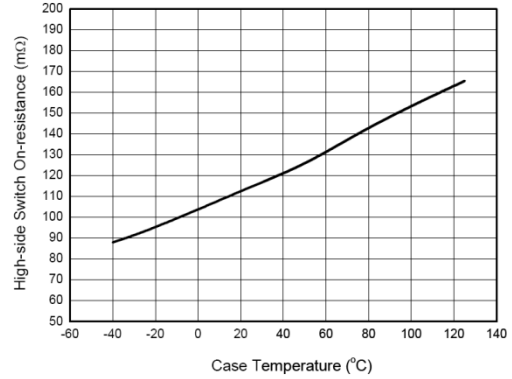

Fig. 5:  $R_{DS(on)H}$  versus case temperature

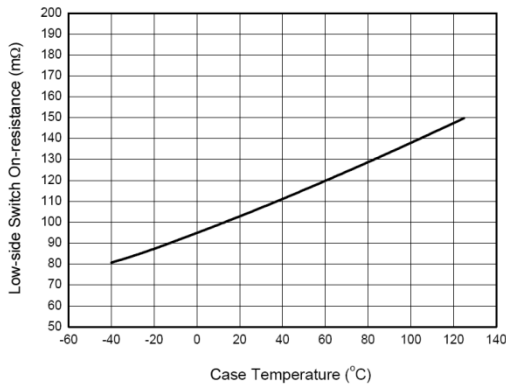

Fig. 6:  $R_{DS(on)L}$  versus case temperature

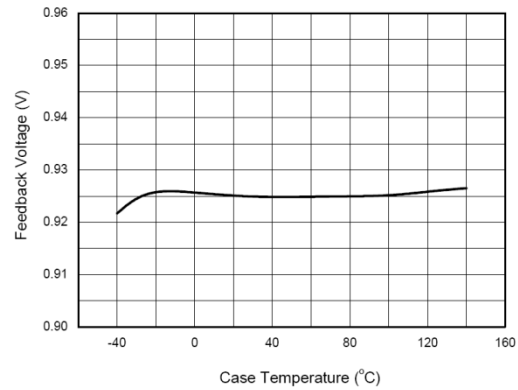

Fig. 7: Feedback voltage versus case temperature

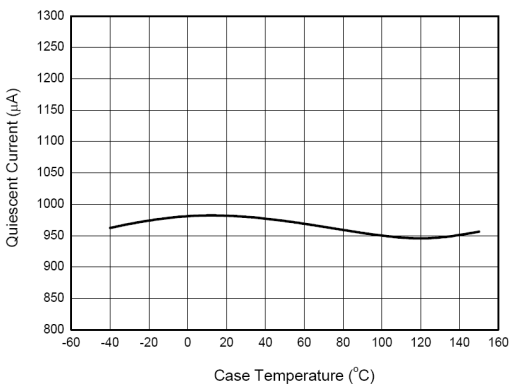

Fig. 8: Quiescent current versus case temperature

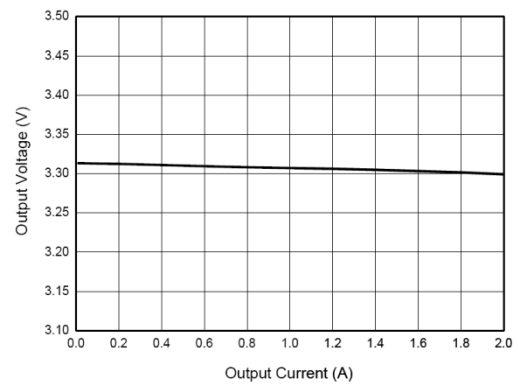

Fig. 9: Output voltage versus output current

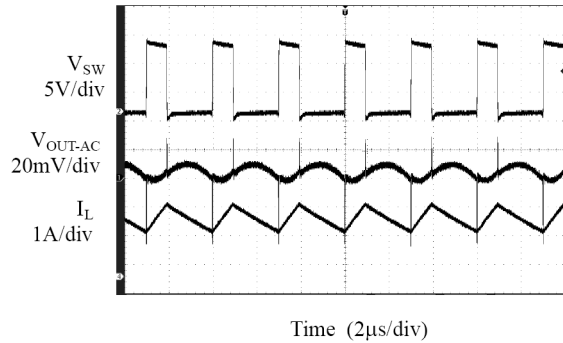

Fig. 10: Output voltage ripple,  $I_{OUT}=2A$

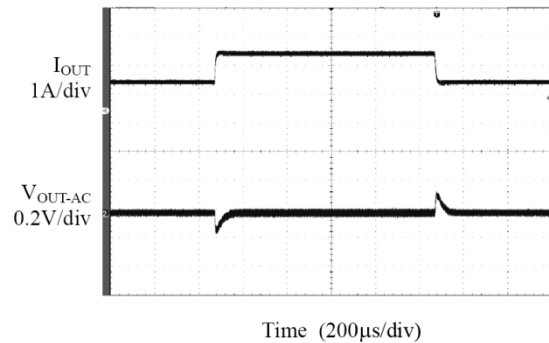

Fig. 11: Load transient ( $I_{OUT}=1A$  to  $2A$ )

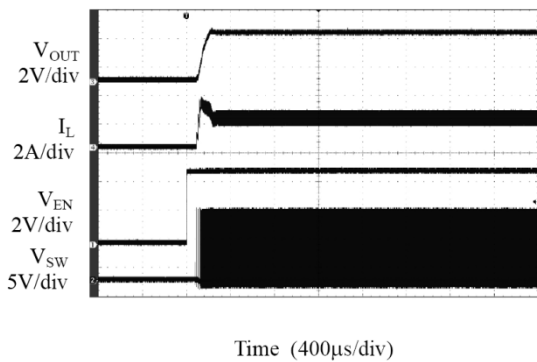

Fig. 12: Enable turn on ( $R_{LOAD}=1.6\Omega$ )

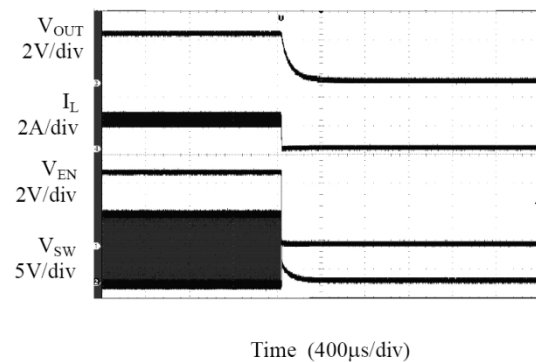

Fig. 13: Enable turn off ( $R_{LOAD}=1.6\Omega$ )

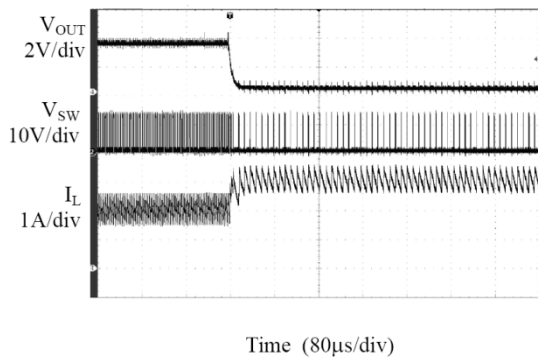

Fig. 14: Short-circuit protection,  $I_{OUT}=2A$

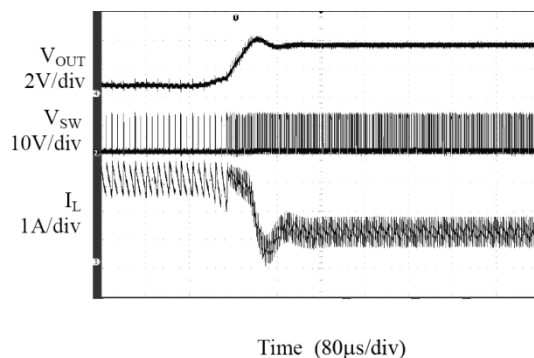

Fig. 15: Short-circuit recovery,  $I_{OUT}=2A$



## THEORY OF OPERATION

### FUNCTIONAL DESCRIPTION

The XRP7664 is a synchronous, current-mode, step-down regulator. It regulates input voltages from 4.75V to 18V and supplies up to 2A of load current. The XRP7664 uses current-mode control to regulate the output voltage. The output voltage is measured at FB through a resistive voltage divider and input to a transconductance error amplifier. The high-side switch current is compared to the output of the error amplifier to control the output voltage. The regulator utilizes internal N-channel MOSFETs to step-down the input voltage. A bootstrapping capacitor connected between BS and SW acts as a supply for high-side MOSFET. This capacitor is charged from the internal 5V supply when SW node is low. The XRP7664 has several powerful protection features including OCP, OVP, OTP, UVLO and output short-circuit.

### PROGRAMMABLE SOFT-START

The soft-start time is fully programmable via CSS capacitor, placed between the SS and GND pin. The CSS is charged by a 6 $\mu$ A constant-current source, generating a ramp signal fed into non-inverting input of the error amplifier. This ramp regulates the voltage on comp pin during the regulator startup, thus realizing soft-start. Calculate the required CSS from:

$$CSS = t_{SS} \times \frac{6\mu A}{V_{FB}}$$

Where:

t<sub>SS</sub> is the required soft-start time

V<sub>FB</sub> is the feedback voltage (0.925V nominal)

### OVERCURRENT PROTECTION OCP

The OCP protects against accidental increase in load current that can cause the regulator to fail. The current of internal switch M1 is monitored. If this current reaches 3.5A then M1 is turned off until next switching cycle.

### SHORT-CIRCUIT PROTECTION

If there is short-circuit across the output, the feedback voltage V<sub>FB</sub> will droop. If V<sub>FB</sub> drops below 0.3V the XRP7664 will detect a short-circuit condition and reduce the switching frequency to 90kHz for system protection. The regulator will restart once the short-circuit has been removed.

### OVERVOLTAGE PROTECTION OVP

The XRP7664 has internal OVP. When V<sub>OUT</sub> exceeds the OVP threshold (when V<sub>FB</sub> exceeds 1.1V) the power switching will be turned off. The XRP7664 will restart when overvoltage condition is removed.

### OVER-TEMPERATURE PROTECTION OTP

If the junction temperature exceeds 160°C the OTP circuit is triggered, turning off the internal control circuit and switched M1 and M2. When junction temperature drops below 130°C the XRP7664 will restart.

## APPLICATION INFORMATION

### SETTING THE OUTPUT VOLTAGE

Use an external resistor divider to set the output voltage. Program the output voltage from:

$$R1 = R2 \times \left( \frac{V_{OUT}}{0.925V} - 1 \right)$$

Where:

R1 is the resistor between V<sub>OUT</sub> and FB

R2 is the resistor between FB and GND (nominally 10k $\Omega$ )

0.925V is the nominal feedback voltage.

### OUTPUT INDUCTOR

Select the output inductor for inductance L, DC current rating I<sub>DC</sub> and saturation current rating I<sub>SAT</sub>. I<sub>DC</sub> should be larger than regulator output current. I<sub>SAT</sub>, as a rule of thumb, should be 50% higher than the regulator output current. Since the regulator is rated at 2A then I<sub>DC</sub>  $\geq$  2A and I<sub>SAT</sub>  $\geq$  3A. Calculate the inductance from:

$$L = (V_{IN} - V_{OUT}) \left( \frac{V_{OUT}}{\Delta I_L \times f_s \times V_{IN}} \right)$$

Where:

$\Delta I_L$  is peak-to-peak inductor current ripple nominally set to 30%-40% of  $I_{OUT}$

$f_s$  is nominal switching frequency (340kHz)

As an example, inductor values for several common output voltages are shown in tables 1 and 2. Note that example inductors shown in tables 1 and 2 are COOPER-Bussmann shielded inductors. If the target application is not sensitive to EMI then unshielded inductors may be used.

VOUT(V)	$\Delta I_{L(p-p)}$ (A)	L( $\mu$ H)	Inductor Example
5.0	0.86	10	DR74-100-R
3.3	0.70	10	DR74-100-R
2.5	0.70	8.2	DR74-8R2-R
1.8	0.66	6.8	DR74-6R8-R
1.5	0.57	6.8	DR74-6R8-R
1.2	0.68	4.7	DR74-4R7-R

Table 1. Suggested inductor values for  $V_{IN}=12V$  and  $I_{OUT}=2A$

VOUT(V)	$\Delta I_{L(p-p)}$ (A)	L( $\mu$ H)	Inductor Example
3.3	0.70	4.7	DR74-4R7-R
2.5	0.78	4.7	DR74-4R7-R
1.8	0.72	4.7	DR74-4R7-R
1.5	0.66	4.7	DR74-4R7-R
1.2	0.57	4.7	DR74-4R7-R

Table 2. Suggested inductor values for  $V_{IN}=5V$  and  $I_{OUT}=2A$

### OUTPUT CAPACITOR $C_{OUT}$

Select the output capacitor for voltage rating, capacitance  $C_{OUT}$  and Equivalent Series Resistance ESR. The voltage rating, as a rule of thumb, should be at least twice the output voltage. When calculating the required capacitance, usually the overriding requirement is current load-step transient. If the unloading transient (i.e., when load transitions from a high to a low current) is met, then usually the loading transient (when

load transitions from a low to a high current) is met as well. Therefore calculate the  $C_{OUT}$  based on the unloading transient requirement from:

$$C_{OUT} = L \times \left( \frac{I_{High}^2 - I_{Low}^2}{(V_{OUT} + V_{transient})^2 - V_{OUT}^2} \right)$$

Where:

L is the inductance calculated in the preceding step

$I_{High}$  is the value of load-step prior to unloading. This is nominally set equal to regulator current rating (2A).

$I_{Low}$  is the value of load-step after unloading. This is nominally set equal to 50% of regulator current rating (1A).

$V_{transient}$  is the maximum permissible voltage transient corresponding to the load step mentioned above.  $V_{transient}$  is typically specified from 3% to 5% of  $V_{OUT}$ .

ESR of the capacitor has to be selected such that the output voltage ripple requirement  $\Delta V_{OUT}$ , nominally 1% of  $V_{OUT}$ , is met. Voltage ripple  $\Delta V_{OUT}$  is mainly composed of two components: the resistive ripple due to ESR and capacitive ripple due to  $C_{OUT}$  charge transfer. For applications requiring low voltage ripple, ceramic capacitors are recommended because of their low ESR which is typically in the range of 5m $\Omega$ . Therefore  $\Delta V_{OUT}$  is mainly capacitive. For ceramic capacitors calculate the  $\Delta V_{OUT}$  from:

$$\Delta V_{OUT} = \frac{\Delta I_L}{8 \times C_{OUT} \times f_s}$$

Where:

$\Delta I_L$  is from table 1 or 2

$C_{OUT}$  is the value calculated above

$f_s$  is nominal switching frequency (340kHz)

If tantalum or electrolytic capacitors are used then  $\Delta V_{OUT}$  is essentially a function of ESR:

$$\Delta V_{OUT} = \Delta I_L \times ESR$$

### INPUT CAPACITOR $C_{IN}$

Select the input capacitor for voltage rating, RMS current rating and capacitance. The voltage rating should be at least 50% higher



than the regulator’s maximum input voltage. Calculate the capacitor’s current rating from:

$$I_{CIN,RMS} = I_{OUT} \times \sqrt{D \times (1 - D)}$$

Where:

$I_{OUT}$  is regulator’s maximum current (2A)

D is duty cycle ( $D=V_{OUT}/V_{IN}$ )

Calculate the  $C_{IN}$  capacitance from:

$$C_{IN} = \frac{I_{OUT} \times V_{OUT} \times (V_{IN} - V_{OUT})}{f_s \times V_{IN}^2 \times \Delta V_{IN}}$$

Where:

$\Delta V_{IN}$  is the permissible input voltage ripple, nominally set at 1% of  $V_{IN}$

**OPTIONAL SCHOTTKY DIODE**

An optional Schottky diode may be paralleled between the GND pin and SW pin to improve the regulator efficiency. Examples are shown in Table 3.

Part Number	Voltage/Current Rating	Vendor
B130	30V/1A	Diodes, Inc.
SK13	30V/1A	Diodes, Inc.
MBRS130	30V/1A	International Rectifier

Table 3. Optional Schottky diode

**EXTERNAL BOOTSTRAP DIODE**

A low-cost diode, such as 1N4148, is recommended for higher efficiency when the input voltage is 5V or the output is 5V or 3.3V. Circuit configuration is shown in figures 16 and 17. The external bootstrap diode is also recommended where duty cycle ( $V_{OUT}/V_{IN}$ ) is larger than 65%.

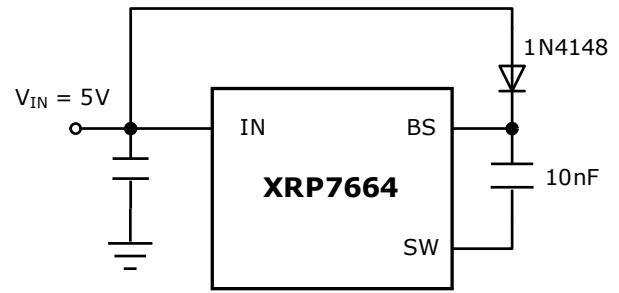

Figure 16. Optional external bootstrap diode where input voltage is fixed 5V

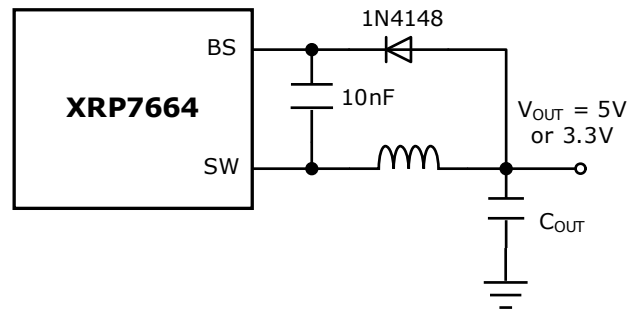

Figure 17. Optional external bootstrap diode where output voltage is 5V or 3.3V

**LOOP COMPENSATION**

XRP7664 utilizes current-mode control. This allows using a minimum of external components to compensate the regulator. In general only two components are needed: RC and CC. Proper compensation of the regulator (determining RC and CC) results in optimum transient response. In terms of power supply control theory, the goals of compensation are to choose RC and CC such that the regulator loop gain has a crossover frequency  $f_c$  between 15kHz and 34kHz. The corresponding phase-margin should be between 45 degrees and 65 degrees. An important characteristic of current-mode buck regulator is its dominant pole. The frequency of the dominant pole is given by:

$$f_p = \frac{1}{2\pi \times C_{OUT} \times R_{load}}$$

where  $R_{load}$  is the output load resistance.

The uncompensated regulator has a constant gain up to its pole frequency, beyond which

the gain decreases at -20dB/decade. The zero arising from the output capacitor's ESR is inconsequential if ceramic  $C_{OUT}$  is used. This simplifies the compensation. The RC and CC, which are placed between the output of XRP7664's Error Amplifier and ground, constitute a zero. The frequency of this compensating zero is given by:

$$f_z = \frac{1}{2\pi \times RC \times CC}$$

For the typical application circuit,  $RC=5.6k\Omega$  and  $CC=3.3nF$  provide a satisfactory compensation. Please contact EXAR if you need assistance with the compensation of your particular circuit.

**TYPICAL APPLICATIONS**

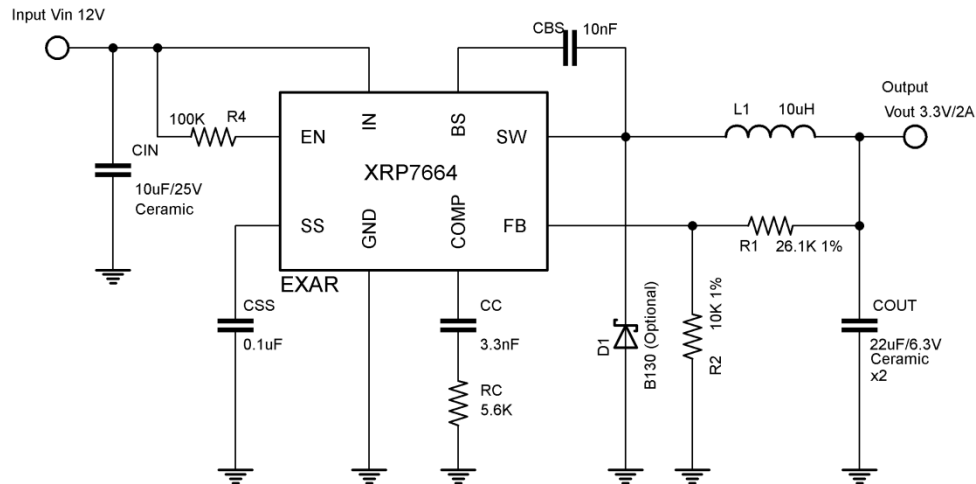
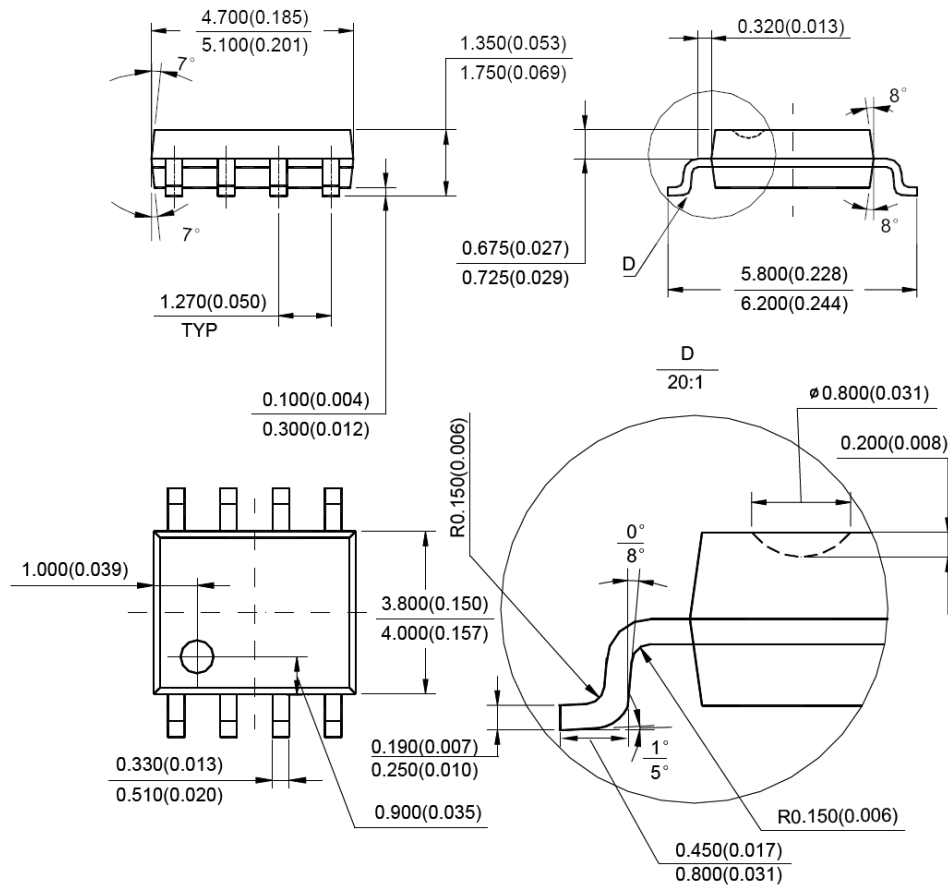

Fig. 16: XRP7664 Typical Application Diagram - 12V to 3.3V Conversion

**PACKAGE SPECIFICATION**

**8-PIN SOIC**

Unit: mm (inch)





**REVISION HISTORY**

Revision	Date	Description
1.0.0	11/02/2010	Initial release of data sheet
1.1.0	12/17/2010	RC(R3) changed from 2.2kΩ to 5.6kΩ - Updated schematics Added the protection features to theory of operation Added figures 16 and 17
1.2.0	10/13/2011	Added MSL level information

**FOR FURTHER ASSISTANCE**

Email:

[customersupport@exar.com](mailto:customersupport@exar.com)

Exar Technical Documentation:

<http://www.exar.com/TechDoc/default.aspx?>

**EXAR CORPORATION**

**HEADQUARTERS AND SALES OFFICES**

48720 Kato Road

Fremont, CA 94538 – USA

Tel.: +1 (510) 668-7000

Fax: +1 (510) 668-7030

[www.exar.com](http://www.exar.com)



**NOTICE**

EXAR Corporation reserves the right to make changes to the products contained in this publication in order to improve design, performance or reliability. EXAR Corporation assumes no responsibility for the use of any circuits described herein, conveys no license under any patent or other right, and makes no representation that the circuits are free of patent infringement. Charts and schedules contained here in are only for illustration purposes and may vary depending upon a user's specific application. While the information in this publication has been carefully checked; no responsibility, however, is assumed for inaccuracies.

EXAR Corporation does not recommend the use of any of its products in life support applications where the failure or malfunction of the product can reasonably be expected to cause failure of the life support system or to significantly affect its safety or effectiveness. Products are not authorized for use in such applications unless EXAR Corporation receives, in writing, assurances to its satisfaction that: (a) the risk of injury or damage has been minimized; (b) the user assumes all such risks; (c) potential liability of EXAR Corporation is adequately protected under the circumstances.

Reproduction, in part or whole, without the prior written consent of EXAR Corporation is prohibited.

Компания «Life Electronics» занимается поставками электронных компонентов импортного и отечественного производства от производителей и со складов крупных дистрибьюторов Европы, Америки и Азии.

С конца 2013 года компания активно расширяет линейку поставок компонентов по направлению коаксиальный кабель, кварцевые генераторы и конденсаторы (керамические, пленочные, электролитические), за счёт заключения дистрибьюторских договоров

Мы предлагаем:

- Конкурентоспособные цены и скидки постоянным клиентам.
- Специальные условия для постоянных клиентов.
- Подбор аналогов.
- Поставку компонентов в любых объемах, удовлетворяющих вашим потребностям.
- Приемлемые сроки поставки, возможна ускоренная поставка.
- Доставку товара в любую точку России и стран СНГ.
- Комплексную поставку.
- Работу по проектам и поставку образцов.
- Формирование склада под заказчика.
- Сертификаты соответствия на поставляемую продукцию (по желанию клиента).
- Тестирование поставляемой продукции.
- Поставку компонентов, требующих военную и космическую приемку.
- Входной контроль качества.
- Наличие сертификата ISO.

В составе нашей компании организован Конструкторский отдел, призванный помогать разработчикам, и инженерам.

Конструкторский отдел помогает осуществить:

- Регистрацию проекта у производителя компонентов.
- Техническую поддержку проекта.
- Защиту от снятия компонента с производства.
- Оценку стоимости проекта по компонентам.
- Изготовление тестовой платы монтаж и пусконаладочные работы.



Тел: +7 (812) 336 43 04 (многоканальный)

Email: [org@lifeelectronics.ru](mailto:org@lifeelectronics.ru)