

# MCH12140, MCK12140

## Phase-Frequency Detector

### Description

The MCH/K12140 is a phase frequency–detector intended for phase–locked loop applications which require a minimum amount of phase and frequency difference at lock. When used in conjunction with high performance VCO such as the MC100EL1648, a high bandwidth PLL can be realized. The device is functionally compatible with the MC12040 phase–frequency detector with the maximum frequency extending to 800 MHz.

When the Reference (R) and VCO (V) inputs are unequal in frequency and/or phase, the differential UP (U) and DOWN (D) outputs will provide pulse streams which when subtracted and integrated provide an error voltage for control of a VCO. See AND8040 for further information. The device is packaged in a small outline, surface mount 8–lead SOIC package. There are two versions of the device to provide I/O compatibility to the two existing ECL standards. The MCH12140 is compatible with MECL 10H™ logic levels while the MCK12140 is compatible to 100 K ECL logic levels. This device can also be used in +5.0 V systems. See AND8020 for termination information

### Features

- 800 MHz Typical Bandwidth
- Small Outline 8-Lead SOIC Package
- 75 kΩ Internal Input Pulldown Resistors
- >1000 V ESD Protection
- Pb–Free Packages are Available

For proper operation, the input edge rate of the R and V inputs should be less than 5.0 ns.



ON Semiconductor®

<http://onsemi.com>

### MARKING DIAGRAM



- x = H or K
- A = Assembly Location
- L = Wafer Lot
- Y = Year
- W = Work Week
- = Pb–Free Package

### PIN CONNECTIONS

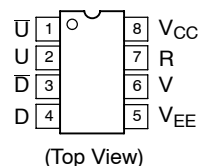

### ORDERING INFORMATION

See detailed ordering and shipping information in the package dimensions section on page 4 of this data sheet.

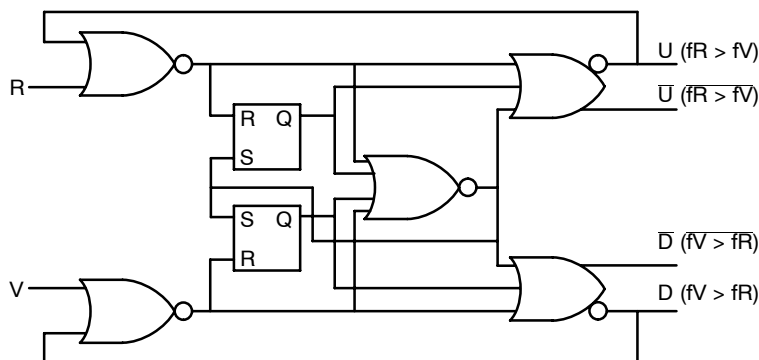

Figure 1. Logic Diagram

# MCH12140, MCK12140

**Table 1. TRUTH TABLE\***

Input		Output				Input		Output			
R	V	U	D	U	D	R	V	U	D	U	D
0	0	X	X	X	X	1	1	0	0	1	1
0	1	X	X	X	X	1	0	0	0	1	1
1	1	X	X	X	X	1	1	0	1	1	0
0	1	X	X	X	X	1	0	0	1	1	0
1	1	1	0	0	1	1	1	0	1	1	0
0	1	1	0	0	1	0	1	0	1	1	0
1	1	1	0	0	1	1	1	0	0	1	1
1	0	1	0	0	1	1	1	0	0	1	1

\*This is not strictly a functional table; i.e., it does not cover all possible modes of operation. However, it gives a sufficient number of tests to ensure that the device will function properly.

**Table 2. H-SERIES DC CHARACTERISTICS** ( $V_{EE} = V_{EE(min)} - V_{EE(max)}$ ;  $V_{CC} = \text{GND}$  (Note 1), unless otherwise noted.)

Symbol	Characteristic	-40°C		0°C		25°C		70°C		Unit
		Min	Max	Min	Max	Min	Max	Min	Max	
$V_{OH}$	Output HIGH Voltage	-1080	-890	-1020	-840	-980	-810	-910	-720	mV
$V_{OL}$	Output LOW Voltage	-1950	-1650	-1950	-1630	-1950	-1630	-1950	-1595	mV
$V_{IH}$	Input HIGH Voltage	-1230	-890	-1170	-840	-1130	-810	-1060	-720	mV
$V_{IL}$	Input LOW Voltage	-1950	-1500	-1950	-1480	-1950	-1480	-1950	-1445	mV
$I_{IL}$	Input LOW Current	0.5	-	0.5	-	0.5	-	0.3	-	μA

**Table 3. K-SERIES DC CHARACTERISTICS** ( $V_{EE} = V_{EE(min)} - V_{EE(max)}$ ;  $V_{CC} = \text{GND}$  (Note 2), unless otherwise noted.)

Symbol	Characteristic	-40°C			0°C to 70°C			Condition	Unit
		Min	Typ	Max	Min	Typ	Max		
$V_{OH}$	Output HIGH Voltage	-1085	-1005	-880	-1025	-955	-880	$V_{IN} = V_{IH(max)}$ or $V_{IL(min)}$	mV
$V_{OL}$	Output LOW Voltage	-1830	-1695	-1555	-1810	-1705	-1620		mV
$V_{OHA}$	Output HIGH Voltage	-1095	-	-	-1035	-	-	$V_{IN} = V_{IH(min)}$ or $V_{IL(max)}$	mV
$V_{OLA}$	Output LOW Voltage	-	-	-1555	-	-	-1610		mV
$V_{IH}$	Input HIGH Voltage	-1165	-	-880	-1165	-	-880	-	mV
$V_{IL}$	Input LOW Voltage	-1810	-	-1475	-1810	-	-1475	-	mV
$I_{IL}$	Input LOW Current	0.5	-	-	0.5	-	-	$V_{IN} = V_{IL(max)}$	μA

# MCH12140, MCK12140

**Table 4. MAXIMUM RATINGS**

Symbol	Rating	Value	Unit
$V_{EE}$	Power Supply ( $V_{CC} = 0\text{ V}$ )	-8.0 to 0	VDC
$V_I$	Input Voltage ( $V_{CC} = 0\text{ V}$ )	0 to -6.0	VDC
$I_{out}$	Output Current Continuous Surge	50 100	mA
$T_A$	Operating Temperature Range	-40 to +70	°C
$V_{EE}$	Operating Range (Note 3)	-5.7 to -4.2	V

Stresses exceeding Maximum Ratings may damage the device. Maximum Ratings are stress ratings only. Functional operation above the Recommended Operating Conditions is not implied. Extended exposure to stresses above the Recommended Operating Conditions may affect device reliability.

NOTE: ESD data available upon request.

- 10H circuits are designed to meet the DC specifications shown in the table after thermal equilibrium has been established. The circuit is in a test socket or mounted on a printed circuit board and transverse airflow greater than 500 lfpm is maintained. Outputs are terminated through a 50  $\Omega$  resistor to -2.0 V except where otherwise specified on the individual data sheets.
- This table replaces the three tables traditionally seen in ECL 100 K data books. The same DC parameter values at  $V_{EE} = -4.5\text{ V}$  now apply across the full  $V_{EE}$  range of -4.2 V to -5.5 V. Outputs are terminated through a 50  $\Omega$  resistor to -2.0 V except where otherwise specified on the individual data sheets.
- Parametric values specified at: H-Series: -4.20 V to -5.50 V  
K-Series: -4.94 V to -5.50 V

**Table 5. DC CHARACTERISTICS** ( $V_{EE} = V_{EE}(\text{min}) - V_{EE}(\text{max})$ ;  $V_{CC} = \text{GND}$ , unless otherwise noted.)

Symbol	Characteristic	-40°C			0°C			25°C			70°C			Unit
		Min	Typ	Max	Min	Typ	Max	Min	Typ	Max	Min	Typ	Max	
$I_{EE}$	Power Supply Current H K	-	45	-	38	45	52	38	45	52	38	45	52	mA
		-	45	-	38	45	52	38	45	52	42	50	58	
$V_{EE}$	Power Supply Voltage H K	-4.75	-5.2	-5.5	-4.75	-5.2	-5.5	-4.75	-5.2	-5.5	-4.75	-5.2	-5.5	V
		-4.20	-4.5	-5.5	-4.20	-4.5	-5.5	-4.20	-4.5	-5.5	-4.20	-4.5	-5.5	
$I_{IH}$	Input HIGH Current	-	-	150	-	-	150	-	-	150	-	-	150	$\mu\text{A}$

NOTE: Device will meet the specifications after thermal equilibrium has been established when mounted in a test socket or printed circuit board with maintained transverse airflow greater than 500 lfpm. Electrical parameters are guaranteed only over the declared operating temperature range. Functional operation of the device exceeding these conditions is not implied. Device specification limit values are applied individually under normal operating conditions and not valid simultaneously.

**Table 6. AC CHARACTERISTICS** ( $V_{EE} = V_{EE}(\text{min}) - V_{EE}(\text{max})$ ;  $V_{CC} = \text{GND}$ , unless otherwise noted.)

Symbol	Characteristic	-40°C			0°C			25°C			70°C			Unit
		Min	Typ	Max	Min	Typ	Max	Min	Typ	Max	Min	Typ	Max	
$F_{MAX}$	Maximum Toggle Frequency	-	800	-	650	800	-	650	800	-	650	800	-	-
$t_{PLH}$ $t_{PHL}$	Propagation Delay-to-Output R, V to D, U	250	375	500	250	375	500	250	375	500	250	375	500	ps
$t_r$ $t_f$	Output Rise/Fall Times Q (20 to 80%)	-	225	-	100	225	350	100	225	350	100	225	350	ps

NOTE: Device will meet the specifications after thermal equilibrium has been established when mounted in a test socket or printed circuit board with maintained transverse airflow greater than 500 lfpm. Electrical parameters are guaranteed only over the declared operating temperature range. Functional operation of the device exceeding these conditions is not implied. Device specification limit values are applied individually under normal operating conditions and not valid simultaneously.

# MCH12140, MCK12140

## APPLICATIONS INFORMATION

The 12140 is a high speed digital circuit used as a phase comparator in an analog phase-locked loop. The device determines the “lead” or “lag” phase relationship and time difference between the leading edges of a VCO (V) signal and a Reference (R) input. Since these edges occur only once per cycle, the detector has a range of  $\pm 2\pi$  radians.

The operation of the 12140 can best be described using the plots of Figure 2. Figure 2 plots the average value of  $\bar{U}$ ,  $\bar{D}$  and the difference between  $\bar{U}$  and  $\bar{D}$  versus the phase difference between the V and R inputs.

There are four potential relationships between V and R: R lags or leads V and the frequency of R is less than or greater than the frequency of V. Under these four conditions the 12140 will function as follows:

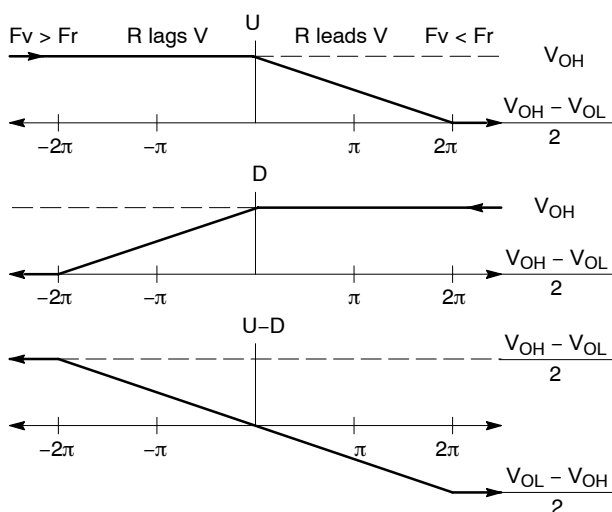

Figure 2. Average Output Voltage vs. Phase Difference

### R lags V in phase

When the R and V inputs are equal in frequency and the phase of R lags that of V the  $\bar{U}$  output will stay HIGH while the  $\bar{D}$  output will pulse from HIGH to LOW. The magnitude of the pulse will be proportional to the phase difference between the V and R inputs reaching a minimum 50% duty cycle under a  $180^\circ$  out of phase condition. The signal on  $\bar{D}$  indicates to the VCO to decrease in frequency to bring the loop into lock.

### V frequency > R frequency

When the frequency of V is greater than that of R the 12140 behaves in a similar fashion as above. Again the signal on  $\bar{D}$  indicates that the VCO frequency must be decreased to bring the loop into lock.

### R leads V in phase

When the R and V inputs are equal in frequency and the phase of R leads that of V the  $\bar{D}$  output will stay HIGH while the  $\bar{U}$  output pulses from HIGH to LOW. The magnitude of the pulse will be proportional to the phase difference between the V and R inputs reaching a minimum 50% duty cycle under a  $180^\circ$  out of phase condition. The signal on  $\bar{U}$  indicates to the VCO to increase in frequency to bring the loop into lock.

### V frequency < R frequency

When the frequency of V is less than that of R the 12140 behaves in a similar fashion as above. Again the signal on  $\bar{U}$  indicates that the VCO frequency must be decreased to bring the loop into lock.

From Figure 2 when V and R are at the same frequency and in phase the value of  $\bar{U} - \bar{D}$  is zero thus providing a zero error voltage to the VCO. This situation indicates the loop is in lock and the 12140 action will maintain the loop in its locked state.

## ORDERING INFORMATION

Device	Package	Shipping†
MCH12140D	SOIC-8	98 Units / Rail
MCH12140DG	SOIC-8 (Pb-Free)	98 Units / Rail
MCH12140DR2	SOIC-8	2500 / Tape & Reel
MCH12140DR2G	SOIC-8 (Pb-Free)	2500 / Tape & Reel
MCK12140D	SOIC-8	98 Units / Rail
MCK12140DG	SOIC-8 (Pb-Free)	98 Units / Rail
MCK12140DR2	SOIC-8	2500 / Tape & Reel
MCK12140DR2G	SOIC-8 (Pb-Free)	2500 / Tape & Reel

†For information on tape and reel specifications, including part orientation and tape sizes, please refer to our Tape and Reel Packaging Specifications Brochure, BRD8011/D.

# MCH12140, MCK12140

## PACKAGE DIMENSIONS

### SOIC-8 NB CASE 751-07 ISSUE AH

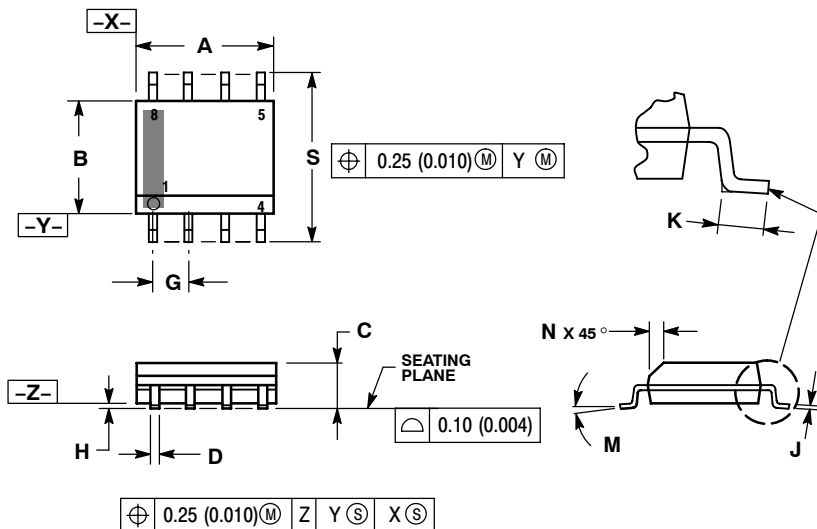

#### NOTES:

1. DIMENSIONING AND TOLERANCING PER ANSI Y14.5M, 1982.
2. CONTROLLING DIMENSION: MILLIMETER.
3. DIMENSION A AND B DO NOT INCLUDE MOLD PROTRUSION.
4. MAXIMUM MOLD PROTRUSION 0.15 (0.006) PER SIDE.
5. DIMENSION D DOES NOT INCLUDE DAMBAR PROTRUSION. ALLOWABLE DAMBAR PROTRUSION SHALL BE 0.127 (0.005) TOTAL IN EXCESS OF THE D DIMENSION AT MAXIMUM MATERIAL CONDITION.
6. 751-01 THRU 751-06 ARE OBSOLETE. NEW STANDARD IS 751-07.

DIM	MILLIMETERS		INCHES	
	MIN	MAX	MIN	MAX
A	4.80	5.00	0.189	0.197
B	3.80	4.00	0.150	0.157
C	1.35	1.75	0.053	0.069
D	0.33	0.51	0.013	0.020
G	1.27 BSC		0.050 BSC	
H	0.10	0.25	0.004	0.010
J	0.19	0.25	0.007	0.010
K	0.40	1.27	0.016	0.050
M	0°	8°	0°	8°
N	0.25	0.50	0.010	0.020
S	5.80	6.20	0.228	0.244

### SOLDERING FOOTPRINT\*

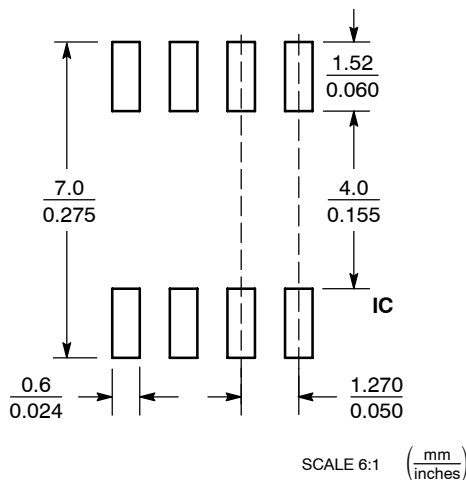

\*For additional information on our Pb-Free strategy and soldering details, please download the ON Semiconductor Soldering and Mounting Techniques Reference Manual, SOLDERRM/D.

MECL 10H is a trademark of Motorola, Inc.

ON Semiconductor and are registered trademarks of Semiconductor Components Industries, LLC (SCILLC). SCILLC reserves the right to make changes without further notice to any products herein. SCILLC makes no warranty, representation or guarantee regarding the suitability of its products for any particular purpose, nor does SCILLC assume any liability arising out of the application or use of any product or circuit, and specifically disclaims any and all liability, including without limitation special, consequential or incidental damages. "Typical" parameters which may be provided in SCILLC data sheets and/or specifications can and do vary in different applications and actual performance may vary over time. All operating parameters, including "Typicals" must be validated for each customer application by customer's technical experts. SCILLC does not convey any license under its patent rights nor the rights of others. SCILLC products are not designed, intended, or authorized for use as components in systems intended for surgical implant into the body, or other applications intended to support or sustain life, or for any other application in which the failure of the SCILLC product could create a situation where personal injury or death may occur. Should Buyer purchase or use SCILLC products for any such unintended or unauthorized application, Buyer shall indemnify and hold SCILLC and its officers, employees, subsidiaries, affiliates, and distributors harmless against all claims, costs, damages, and expenses, and reasonable attorney fees arising out of, directly or indirectly, any claim of personal injury or death associated with such unintended or unauthorized use, even if such claim alleges that SCILLC was negligent regarding the design or manufacture of the part. SCILLC is an Equal Opportunity/Affirmative Action Employer. This literature is subject to all applicable copyright laws and is not for resale in any manner.

### PUBLICATION ORDERING INFORMATION

LITERATURE FULFILLMENT:  
Literature Distribution Center for ON Semiconductor  
P.O. Box 5163, Denver, Colorado 80217 USA  
Phone: 303-675-2175 or 800-344-3860 Toll Free USA/Canada  
Fax: 303-675-2176 or 800-344-3867 Toll Free USA/Canada  
Email: orderlit@onsemi.com

N. American Technical Support: 800-282-9855 Toll Free  
USA/Canada  
Europe, Middle East and Africa Technical Support:  
Phone: 421 33 790 2910  
Japan Customer Focus Center  
Phone: 81-3-5773-3850

ON Semiconductor Website: [www.onsemi.com](http://www.onsemi.com)  
Order Literature: <http://www.onsemi.com/orderlit>

For additional information, please contact your local Sales Representative

Компания «Life Electronics» занимается поставками электронных компонентов импортного и отечественного производства от производителей и со складов крупных дистрибьюторов Европы, Америки и Азии.

С конца 2013 года компания активно расширяет линейку поставок компонентов по направлению коаксиальный кабель, кварцевые генераторы и конденсаторы (керамические, пленочные, электролитические), за счёт заключения дистрибьюторских договоров

Мы предлагаем:

- Конкурентоспособные цены и скидки постоянным клиентам.
- Специальные условия для постоянных клиентов.
- Подбор аналогов.
- Поставку компонентов в любых объемах, удовлетворяющих вашим потребностям.
- Приемлемые сроки поставки, возможна ускоренная поставка.
- Доставку товара в любую точку России и стран СНГ.
- Комплексную поставку.
- Работу по проектам и поставку образцов.
- Формирование склада под заказчика.
- Сертификаты соответствия на поставляемую продукцию (по желанию клиента).
- Тестирование поставляемой продукции.
- Поставку компонентов, требующих военную и космическую приемку.
- Входной контроль качества.
- Наличие сертификата ISO.

В составе нашей компании организован Конструкторский отдел, призванный помогать разработчикам, и инженерам.

Конструкторский отдел помогает осуществить:

- Регистрацию проекта у производителя компонентов.
- Техническую поддержку проекта.
- Защиту от снятия компонента с производства.
- Оценку стоимости проекта по компонентам.
- Изготовление тестовой платы монтаж и пусконаладочные работы.



Тел: +7 (812) 336 43 04 (многоканальный)

Email: [org@lifeelectronics.ru](mailto:org@lifeelectronics.ru)