

TENTATIVE SPECIFICATIONS

DATE Aug.27 2013

PRODUCT NAME: LC706200CM

1. Case Outline: Wafer Ring(8inch)
2. Function: Semiconductor IC for Digital Silicon Microphone includes Pre-amplifier and Sigma Delta Modulator and Charge Pump.
3. Application: Cellular phone and other
4. Absolute Maximum Ratings at Ta=25°C, GND = 0V

Parameter	Symbol	Pin Name	Min	Max	Units
Maximum power supply voltage	V _{DD} max	VDD	-0.3	+4.0	V
Maximum input voltage	V _{CLK} max	CLK,CLKSEL	-0.3	VDD+0.3	V
	V _{IN} max	IN	-0.3	VDD+0.3	V
Maximum output voltage	V _{omax}	DATA	-0.3	VDD+0.3	V
Operating temperature range	Ta		-30	70	°C
Storage temperature range	Tstg		-40	85	°C

Stresses exceeding Maximum Ratings may damage the device. Maximum Ratings are stress ratings only. Functional operation above the Recommended Operating Conditions is not implied. Extended exposure to stresses above the Recommended Operating Conditions may affect device reliability.

Pad Coordinate (0,0)

PAD Size

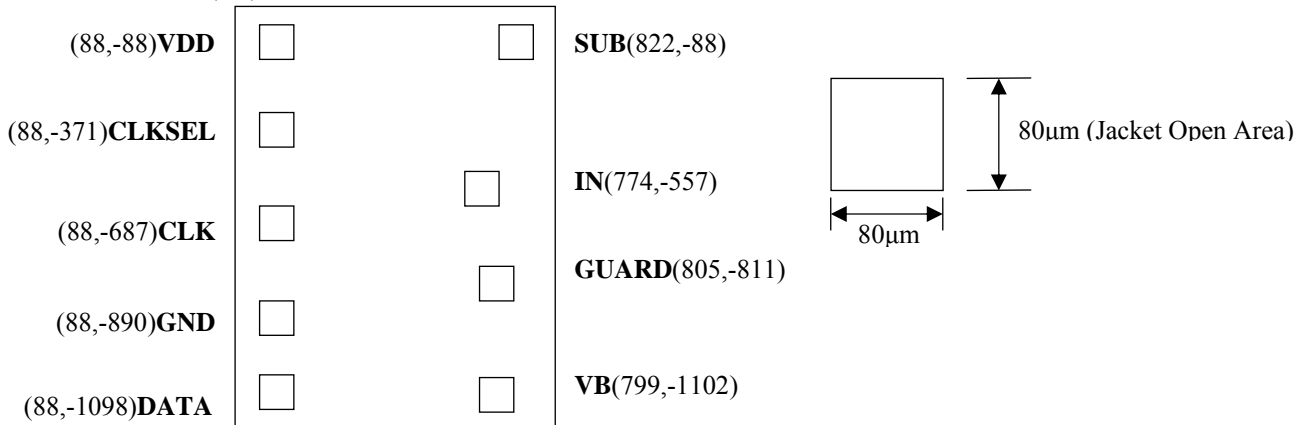

5. Circuit Parameters

Parameter	Symbol	Pin Name	Test Condition	Min	Typ	Max	Units
Input capacitance of die	C _{in}	IN			0.4		pF

Note: IN-Pin has a limited protection against ESD. Value of IN-Pin is proven by design.

6. DC Electrical Characteristics Ratings at Ta=25°C, VDD=3.3V, GND=0V, Fclk=2.4MHz, Fduty =50%

Parameter	Symbol	Pin Name	Condition	Min	Typ	Max	Units
Power supply voltage	VDD	VDD		1.64	3.3	3.6	V
Power consumption (IO Power consumption is not Included)	IDD	VDD	VDD=3.3V		800		uA
Standby Current	ISTBY	VDD	VDD=3.3V			200	nA
Input/Output LOW level	V _{iol}	CLK, DATA CLKSEL	DATA : I _{ol} =0.5mA			0.35×VDD	V
Input/Output HIGH level	V _{ioh}	CLK, DATA CLKSEL	DATA : I _{oh} =-0.5mA	0.65×VDD			V

(-)

Charge pump voltage	Vbias	VB/SUB	VDD=3.3V		10.5		V
Parameter	Symbol	Pin Name	Condition	Min	Typ	Max	Units
Charge Pump voltage tolerance	Tolerance	VB/SUB		-8		+8	%

7. AC Electrical Characteristics Ratings at Ta=+25°C, VDD=3.3V, GND=0V, Signal Frequency=1KHz, Measurement frequency=100Hz~20KHz, Fclk=2.4MHz, Fduty =50%, Bypass capacitor=0.1uF(VDD-GND)

Parameter	Symbol	Pin Name	Condition	Min	Typ	Max	Units
Clock Frequency (Normal Operation)	Fclk	CLK		1	2.4	3.25	MHz
Clock Frequency (Sleep Mode)	Fclk_SL	CLK				1	KHz
Clock Duty	Fduty	CLK		40		60	%
Over Sampling Ratio	OSR				50		
Maximum Input Voltage (Input Full Scale Voltage)	Vin	IN	0dBFS (= 120dB SPL)		158.5		mVrms
THD / THD+N	THD_0	DATA	Vout=0dBFS (= 120dB SPL) (= 158.5mVrms)			10	% (THD)
	THD+N_1 ※1	DATA	Vout=-5dBFS (= 115dB SPL) (= 89.1mVrms) 1KHz Sin-Wave			5	% (THD+N)
	THD+N_2 ※1	DATA	Vout=-20dBFS (= 100dB SPL) (= 15.8mVrms) 50-4KHz Sin-Wave			1	% (THD+N)
Digital Noise Floor	DNF1	DATA	Bandwidth 20KHz A-weighted		-87		dBFS
PSRR ※1	PSRR	DATA	217Hz Square, 10MHz-Broadband Noise, 100mVpp		-70		dBFS
Transfer function ※2	TF1	DATA			18		dB
Wake Up Time ※1	WUT	CLK	Fclk=2.4MHz			10	ms
Fall Asleep Time ※1	FAT		Fclk=1KHz			10	ms

Note1 : ※1 are Reference data:No measurement.

Note2 : ※2 Each product has been designed with performance of +/-0.5dB tolerance for transfer function however it's not checked in outgoing inspection.

Note3: Input Full Scale Voltage 0dBFS is equivalent to 120dB SPL (= 158.5mVrms).

Note4: SNR Input Level Condition is -26dBFS (= 7.9mVrms, 94dB SPL, 1Pa).

Block Diagram

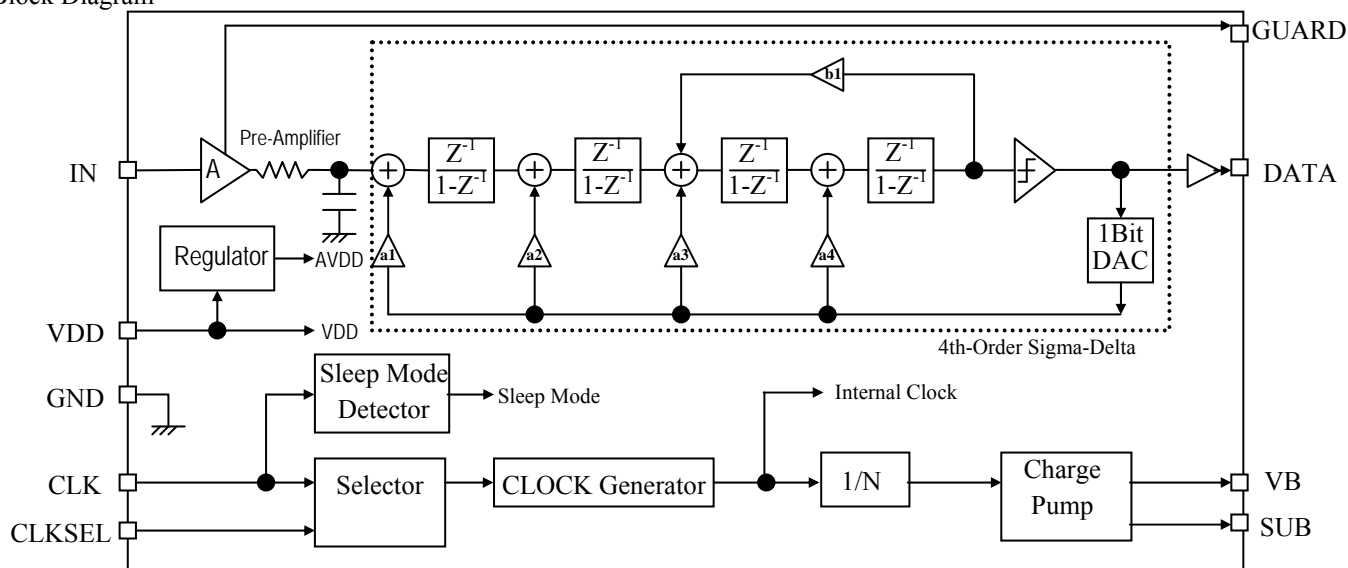

Pin Descriptions

No.	Pin Name	Function	I/O	Pin conditions
-	GND	Ground	—	—
-	VDD	Power Supply	—	—
-	GUARD	Connect to GUARD of MEMS	—	—
-	SUB	Connect to SUB of MEMS	—	—
-	DATA	PDM Data Output	output	
-	CLKSEL	CLK Select signal input Case1: When CLKSEL is LOW, PDM data is outputted in sync with negative edge of CLK. Case2: When CLKSEL is HIGH, PDM data is outputted in sync with positive edge of CLK.	Input	
-	CLK	Clock input	Input	
-	VB	Charge Pump Voltage Output	output	-
-	IN	Audio signal input	Input	

Switching Characteristics

(Ta=+25°C, VDD=1.8V, GND=0V, Fclk=2.4MHz, Fduty=50%)

Case1 : CLKSEL=LOW

Parameter	Symbol	Pin Name	Condition	Min	Typ	Max	Units
Clock Rise Time	Tcr	CLK				10	ns
Clock Fall Time	Tcf	CLK				10	ns
Output Data Delay	Tpd_l	DATA	CL=13pF,RL=1MΩ	20	31	40	ns
Output Hi-Z Delay	Tpzd_l	DATA	CL=13pF,RL=1MΩ	0	8	15	ns

Note1: Tpd_l > Tpzd_l

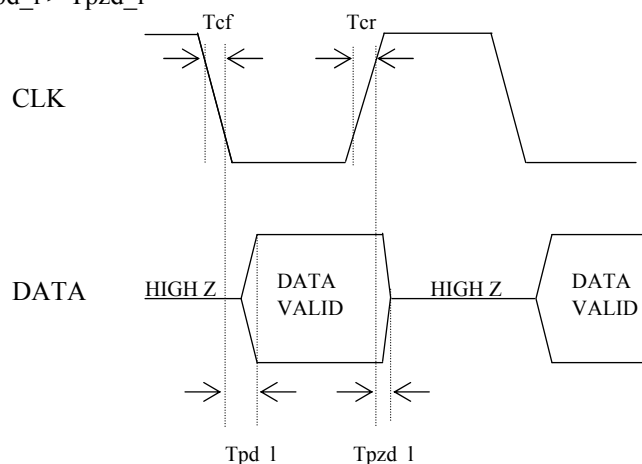

Case2 : CLKSEL=HIGH

Parameter	Symbol	Pin Name	Condition	Min	Typ	Max	Units
Clock Rise Time	Tcr	CLK				10	ns
Clock Fall Time	Tcf	CLK				10	ns
Output Data Delay	Tpd_h	DATA	CL=13pF,RL=1MΩ	20	31	40	ns
Output Hi-Z Delay	Tpzd_h	DATA	CL=13pF,RL=1MΩ	0	8	15	ns

Note2: Tpd_h > Tpzd_h

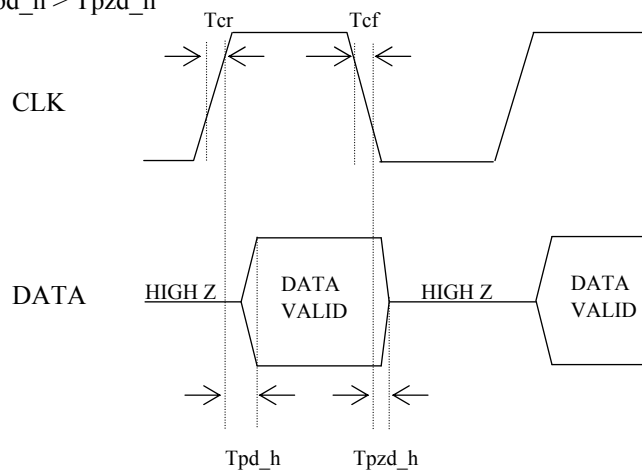

ON Semiconductor and the ON logo are registered trademarks of Semiconductor Components Industries, LLC (SCILLC). SCILLC owns the rights to a number of patents, trademarks, copyrights, trade secrets, and other intellectual property. A listing of SCILLC's product/patent coverage may be accessed at www.onsemi.com/site/pdf/Patent-Marking.pdf. SCILLC reserves the right to make changes without further notice to any products herein. SCILLC makes no warranty, representation or guarantee regarding the suitability of its products for any particular purpose, nor does SCILLC assume any liability arising out of the application or use of any product or circuit, and specifically disclaims any and all liability, including without limitation special, consequential or incidental damages. "Typical" parameters which may be provided in SCILLC data sheets and/or specifications can and do vary in different applications and actual performance may vary over time. All operating parameters, including "Typicals" must be validated for each customer application by customer's technical experts. SCILLC does not convey any license under its patent rights nor the rights of others. SCILLC products are not designed, intended, or authorized for use as components in systems intended for surgical implant into the body, or other applications intended to support or sustain life, or for any other application in which the failure of the SCILLC product could create a situation where personal injury or death may occur. Should Buyer purchase or use SCILLC products for any such unintended or unauthorized application, Buyer shall indemnify and hold SCILLC and its officers, employees, subsidiaries, affiliates, and distributors harmless against all claims, costs, damages, and expenses, and reasonable attorney fees arising out of, directly or indirectly, any claim of personal injury or death associated with such unintended or unauthorized use, even if such claim alleges that SCILLC was negligent regarding the design or manufacture of the part. SCILLC is an Equal Opportunity/Affirmative Action Employer. This literature is subject to all applicable copyright laws and is not for resale in any manner.

Компания «Life Electronics» занимается поставками электронных компонентов импортного и отечественного производства от производителей и со складов крупных дистрибьюторов Европы, Америки и Азии.

С конца 2013 года компания активно расширяет линейку поставок компонентов по направлению коаксиальный кабель, кварцевые генераторы и конденсаторы (керамические, пленочные, электролитические), за счёт заключения дистрибьюторских договоров

Мы предлагаем:

- Конкурентоспособные цены и скидки постоянным клиентам.
- Специальные условия для постоянных клиентов.
- Подбор аналогов.
- Поставку компонентов в любых объемах, удовлетворяющих вашим потребностям.
- Приемлемые сроки поставки, возможна ускоренная поставка.
- Доставку товара в любую точку России и стран СНГ.
- Комплексную поставку.
- Работу по проектам и поставку образцов.
- Формирование склада под заказчика.
- Сертификаты соответствия на поставляемую продукцию (по желанию клиента).
- Тестирование поставляемой продукции.
- Поставку компонентов, требующих военную и космическую приемку.
- Входной контроль качества.
- Наличие сертификата ISO.

В составе нашей компании организован Конструкторский отдел, призванный помогать разработчикам, и инженерам.

Конструкторский отдел помогает осуществить:

- Регистрацию проекта у производителя компонентов.
- Техническую поддержку проекта.
- Защиту от снятия компонента с производства.
- Оценку стоимости проекта по компонентам.
- Изготовление тестовой платы монтаж и пусконаладочные работы.



Тел: +7 (812) 336 43 04 (многоканальный)

Email: org@lifeelectronics.ru