

SPSTET4-01

Power Shelf

SPSTET4-01 power-shelf solutions provide rectification, system management, and power distribution, while maintaining high reliability and offering flexibility for future expansion.

The power shelf can be configured with up to six hot-swap capable TET4000-48-069RA AC/DC-DC power supplies that convert 3-phase AC mains power into a main output of 54.5 VDC for powering IT racks, OCP racks and Data centers.

The shelf has an optional slot for Network Attached Controller for providing control functions and monitoring through a 10/100 MB base Ethernet port and can be connected directly to the data center management network.

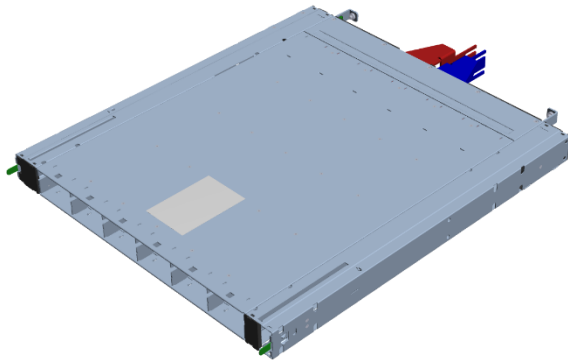

Key Features & Benefits

- Two 3-Phase inputs, one AC inlet powers 3 power modules.
- Modules are hot-swap capable
- Modules support CAN communication interface for control, programming and monitoring with CAN communication protocol
- Modules implement the following protections: Overtemperature, output overvoltage and output overcurrent
- Overall dimensions: 436.5 x 47 x 710 mm (17.2 x 1.85 x 27.9 in)
- RoHS Compliant

Applications

- IT racks
- OCP racks
- Data centers



bel POWER
SOLUTIONS &
PROTECTION

a bel group

belfuse.com/power-solutions

1. ORDERING INFORMATION

MODEL	INPUT AND OUTPUT CONFIGURATION
SPSTET4-01	3-phase, 200-277 / 346-480 VAC Line to Line input with Neutral line Single output blade for +54.5 V output for OCP Shallow Rack.
SPSTET4-01C	3-phase, 200-277 / 346-480 VAC Line to Line input with Neutral line Single output blade for +54.5 V output for OCP Shallow Rack. Network Attached Controller included

2. TECHNICAL DATA

PARAMETER	DESCRIPTION / CONDITION
Input	3-phase, 200-277 / 346-480 VAC Line to Line input with Neutral ¹
AC Inlet Configuration	3 power modules are powered from one AC inlet
Auxiliary AC Outlet	3pcs. low power AC outlet providing 230 / 277 VAC output with max. 6A – 10A, Protected by T 10A – F 15 A / 500 VAC Fuse (serviceable) When T _A : +45 °C to +55 °C, Output load current must be derated to 75%.
Redundant Configuration	5+1 configuration
Rated Power	19260 W ²
Output Connection	1 set of output blade for +54.5 VDC output
Standby Output	60 W (Standby output 12 V / 5 A)
Communication	CAN Interface / Ethernet – SNMPv3/ HTTPs / USB 2.0
NAC1026-01	Network Attached Controller: Ethernet – SNMPv3 / HTTP

3. SAFETY WARNING

The user assumes all responsibility and liability for proper and safe handling of the goods. Further, the user indemnifies Bel Power Solutions Inc. from all claims arising from the handling or use of the goods. Persons handling the product(s) must have electronics training and observe good engineering practice standards.

CAUTION: Multiple power source. Disconnect all power cords before servicing.

4. REFERENCE DOCUMENTS

DOCUMENT NUMBER	DESCRIPTION
BCD.00883	TET4000-48-069RA Datasheet
BCA.00231.0	TET4000-48-069RA CAN Communication Manual
BCA.00253.0	Network Attached Controller Documentation
BCA.00254.0	SPSTET4-0x CAN Communication Manual
BCA.00255.0	SPSTET4-0x HID Communication Manual
BCM.00TBD	Installation Instruction SPSTET4-0x

¹ Power modules are connected Line to Neutral.

² Rated Power is reduced as per current share accuracy characteristic. See TET4000-48-069RA Datasheet.

5. OVERVIEW

The SPSTET4-01 Power Shelf is a 10U height power shelf. It can be configured with up to six hot-swap capable TET4000-48-069RA AC/DC power supplies that convert standard AC mains power into a main output of 54.5 VDC for powering IT racks, OCP racks and Data centers.

The CAN communication is routed through the CAN BUS inside the shelf. PSU Modules support CAN communication interface for control, programming and monitoring with the CAN communication protocol.

The shelf has a slot for network attached controller (NAC) for providing control functions and monitoring through a 10/100 MB base Ethernet port and can be connected directly to the data center management network. It is hot-pluggable and supplied via the 12 V standby provided by the power supplies in the shelf. The controller can be configured through a web interface; the monitoring and control functions are accessed through SNMPv3.

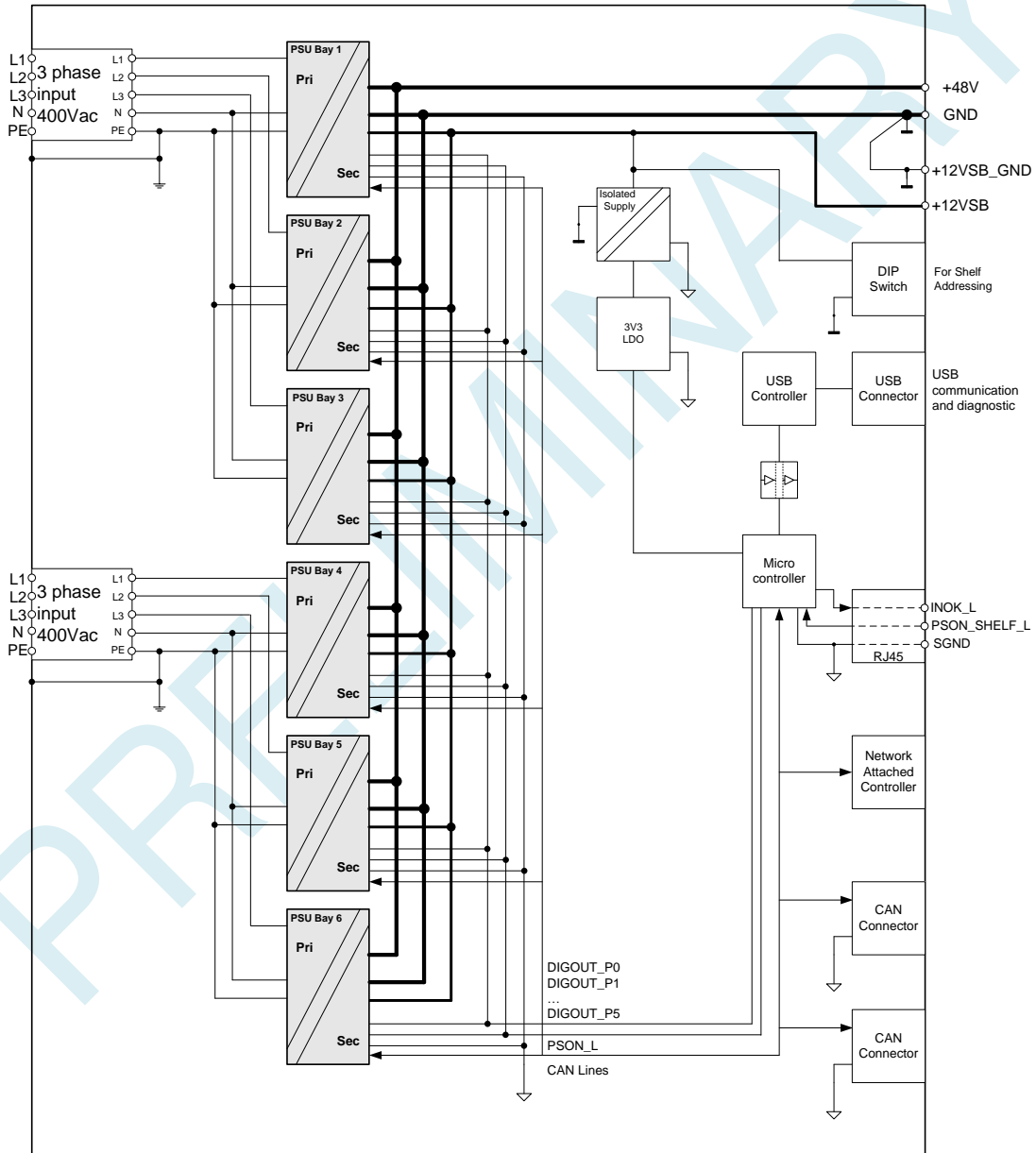

Figure 1. SPSTET4-01 Block Diagram (will be updated for Auxiliary AC Outlet)

6. INPUT SPECIFICATIONS

PARAMETER	DESCRIPTION / CONDITION	MIN	NOM	MAX	UNIT
<i>Input Connector (J106, J107)</i>					
AC Nominal Input Voltage	Line to Line input		400 / 480		VAC
AC Input Voltage Ranges	Line to Neutral input	180		300	VAC
Max Input Current	per line			28	Arms
Input Frequency		47	50 / 60	63	Hz

7. OUTPUT SPECIFICATIONS

PARAMETER	DESCRIPTION / CONDITION	MIN	NOM	MAX	UNIT
<i>Main Output V1 (Output Bus Bar)</i>					
Nominal Output Voltage			54.5		VDC
Voltage Regulation	Programmable PSU module	-12		+6.5	% Vout nom
Nominal Output Power	5+1 configuration, $T_a < 45^\circ\text{C}$			19200	W
Derated Output Power	5+1 configuration, $T_a = 55^\circ\text{C}$			14400	W
Nominal Output Current	5+1 configuration, $T_a < 45^\circ\text{C}$			352	ADC
Derated Output Current	5+1 configuration, $T_a = 55^\circ\text{C}$			264	ADC

<i>Standby Output VSB (J23)</i>					
Output Voltage			12		VDC
Voltage Regulation		-5		+5	% Vout nom
Output Power				60	W
Output Current				5	ADC

<i>Auxiliary AC Outlet (J123, J124, and J125)</i>					
AC Output Voltage (J123)	L1 to Neutral		230 / 277		VAC
AC Output Voltage (J124)	L2 to Neutral		230 / 277		VAC
AC Output Voltage (J125)	L3 to Neutral		230 / 277		VAC
AC Output Current (J123)	L3 to Neutral			6	Arms
AC Output Current (J124, J125)	L1, L2 to Neutral			10	Arms
Fuse Protection per Line (F123)	Serviceable (10 A / 500 VAC Time Lag fuse)				
Fuse Protection per Line (F124, F125)	Serviceable (15 A / 500 VAC Fast-Acting fuse)				

Note: When T_a : $+45^\circ\text{C}$ to $+55^\circ\text{C}$, Output load current must be derated to 75%.

7.1 PROTECTION (PER MODULE)

PARAMETER	DESCRIPTION / CONDITION	MIN	NOM	MAX	UNIT
Input Fuses (L+N)	Not user accessible, fast-acting (F)		30		A
OV Threshold I_1	Hardware protection	64	67	70	VDC
OV Latch Off Time I_1				1	ms
Nominal Power Limitation	$V_{in} > 180V_{ac}$, $T_a \leq 45^{\circ}C$, $V_1 \geq 48$ VDC	4000	4100		W
Nominal Current Limitation	$V_{in} > 180V_{ac}$, $T_a \leq 45^{\circ}C$, $V_1 \geq 48$ VDC	73	76		A
Power Limit Blanking Time	Time until power limit is reduced to nominal value		5		ms
Power limit during oversubscription V_1	Maximum duration 5 ms	4400	4500		W
Current limit during Oversubscription I_1	Maximum duration 5ms	83	86		A
Max Short Circuit Current I_1	$V_1 < 10$ VDC			83 ³	A
Short Circuit Latch Off Time	Time to latch off when in short circuit or output under voltage ($V_1 < 42$ VDC)		20		ms
UV Threshold V_1	Output under voltage protection	42.5	43	43.5	VDC
V_1 Output under voltage protection delay time	$V_1 < V_1_{uv}$		20		ms
Over Temperature on Critical Points	Inlet Ambient Temperature			60	°C
	PFC Primary Heatsink Temperature			90	
	Secondary Sync Mosfet Temperature			90	
	Secondary OR-ing Mosfet Temperature			100	
UV Threshold V_{SB}	Output under voltage protection standby	11	11.2	11.3	VDC
Current Limitation V_{SB}	Standby over current limit		5.5		A

7.2 LOGIC SIGNALS

PSON_SHELF_L signal is an internally pulled-up input signal (3.3 V) to enable / disable the main output V_1 of the Shelf. This active-low pin is also used to clear any latched fault condition, this is similar to the PSON_L on the PSU level. The internal INOK_L_Px signal of each individual module is fed to the backplane microcontroller for modules synchronized AC startup. This allows the shelf to start up with load > 4000 W during AC application. The microcontroller provides an INOK_L output signal. INOK_L is low when there is at least one module supplied with correct input voltage. A pull up resistor of 10k Ω to 3.3 V within the shelf provides the high-level voltage for the INOK_L signal.

RJ11 PIN OUTS (J15)	FUNCTION	DESCRIPTION
1	NC	NC
2	INOK_L	INOK signal: active-low
3	PSON_SHELF_L	Power shelf on input: active-low
8	SGND	Signal ground

Table 1. Signal Connector (RJ11) Pin Out

³ Limit doesn't include effects of main output capacitive discharge

7.3 CAN COMMUNICATION

The PSU Modules are individually set to six fixed different address. CAN communication for the PSU Modules are described in more detail in document BCA.00231. The CAN communication to the PSU Modules are routed through CAN BUS. The PSON function of the shelf can also be controlled by a command similar to PMBus® command sent to the backplane Controller, see document BCA.00254.0 for further information and the table below.

There is a dual port Dsub9 connector for daisy chain operations.

The current share between different shelves is achieved by daisy chain connection of the CAN connectors.

Dsub 9 PIN OUTS (J13)	FUNCTION	DESCRIPTION
1	NC	NC
2	CAN_L	Dominant Low
3	CAN_GROUND	Ground
4	NC	NC
5	CAN_SHIELD	Shield, Optional
6	CAN_GROUND	Ground, Optional
7	CAN_H	Dominant High
8	NC	NC
9	NC	NC

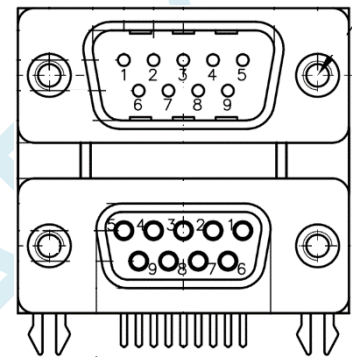

Front View

7.4 PSU / SHELF ADDRESSING

The PSU address inside shelf are configurable via DIP Switch (S1);

The Default Shelf Controller Node address is 0x0F.

POSITION 1	POSITION 2	POSITION 3	PSU Address PSU1, PSU2...PSU6		
			PSU1	PSU2	PSU6
OFF	OFF	OFF	0x01	0x02	0x06
OFF	OFF	ON	0x11	0x12	0x16
OFF	ON	OFF	0x21	0x22	0x26
OFF	ON	ON	0x31	0x32	0x36
ON	OFF	OFF	0x41	0x42	0x46
ON	OFF	ON	0x51	0x52	0x56
ON	ON	OFF	0x61	0x62	0x66
ON	ON	ON	0x71	0x72	0x76

NOTE: SPSTET4-0x CAN Communication Manual, see document BCA.00254.0

Table 2. DIP Switch Setting (S1)

7.5 NETWORK ATTACHED CONTROLLER (optional)

The Network Attached Controller is a shelf level controller providing monitoring and control functions through a 10/100 MB base Ethernet port and can be connected directly to the data center management network. It is hot-pluggable and supplied via the 12 V redundant standby provided by the power supplies in the shelf. The controller can be configured through a web interface; the monitoring and control functions are accessed through SNMP.

See BCA.00253.0 for Network Attached Controller Documentation.



Asia-Pacific +86 755 298 85888 Europe, Middle East +353 61 225 977 North America +1 408 785 5200

7.6 CONTROL LEDs

Each PSU front-end module has 2 LEDs to indicate status condition. LED number one is green and indicates AC power is on or off, while LED number two is bi-colored: green and yellow and indicates DC power presence or fault situations.

OPERATING CONDITION	LED SIGNALING
AC LED	
AC Line within range	Solid Green
AC Line UV condition	Off
DC LED⁴	
V_1 or V_{SB} out of regulation	Solid Yellow
Over temperature shutdown	
Output over voltage shutdown (V_1 or V_{SB})	
Output under voltage shutdown (V_1 or V_{SB})	
Output over current shutdown (V_1 or V_{SB})	Blinking Yellow
Invalid Node Id	
Power Supply Turned Off	Blinking Green
Normal Operation	Solid Green
PSU back-supplied	Blinking Yellow
Otherwise	All LEDs off

7.7 +12VSB CONNECTOR (J23)

+12VSB output is capable of delivering 5 A.

PIN OUTS (J23)	FUNCTION	DESCRIPTION
1, 3	VSB_GND	+12VSB return
2, 4	VSB	+12VSB output

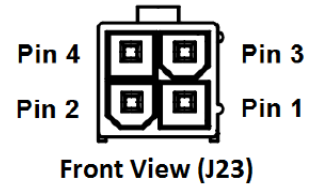

7.8 AUXILIARY AC OUTLET

The 3 connectors (J123, J124, and J125) are used to provide AC power to the Network Switch Devices. Each connector is connected to one of the LIVE terminals (L1, L2, and L3) and NEUTRAL from the 3-phase input (J107). These are protected by a 10 A / 500 Vac Time Lag fuse on the LIVE terminal (F123) and 15 A / 500 Vac Fast-Acting fuse on the LIVE terminal (F124 and F125). See Safety Warning when servicing the fuse.

When power shelf is operated at ambient temp of +45 °C to +55 °C, the output load current must be derated to 75%.

⁴ The order of the criteria in the table corresponds to the testing precedence in the controller. LEDs are only available if sufficient input voltage is applied for operation of the internal supply circuits.

8. SAFETY, REGULATORY AND EMC SPECIFICATIONS

PARAMETER	DESCRIPTION / CONDITION	CRITERION
Agency Approvals Pending	Approved to the latest revisions/amendments of the following standards: UL 62368-1 2nd edition CAN/CSA-C22.2 No. 62368-1 2nd edition IEC 62368-1 2nd edition EN 62368-1 2nd edition	Approved by independent body (see CE Declaration)
Insulation	Input (L/N) to case (PE) Input (L/N) to output Output to case (PE)	Basic Reinforced Functional
Creepage / Clearance (<i>dc</i>)	Primary (L/N) to protective earth (PE) Primary to secondary	
Electrical Strength Test	Input to case Input to output (tested by manufacturer only)	Min. 2121 VDC Min. 4242 VDC
Conducted Emission	EN55022 / CISPR 22: 0.15 ... 30 MHz, QP and AVG	Class A
Radiated Emission	EN55022 / CISPR 22: 30 MHz ... 1 GHz, QP	Class A
Harmonic Emissions (per module)	IEC61000-3-2, $V_{in} = 230$ VAC, 50 Hz, 100% Load (per module)	Class A
Acoustical Noise	Sound power statistical declaration (ISO 9296, ISO 7779, IS9295) @ 50% load	TBD dBA
AC Flicker	IEC / EN 61000-3-3, $d_{max} < 3.3\%$	PASS
ESD Contact Discharge	IEC / EN 61000-4-2, ± 8 kV, 25+25 discharges per test point (metallic case, LEDs, connector body)	A
ESD Air Discharge	IEC / EN 61000-4-2, ± 15 kV, 25+25 discharges per test point (non-metallic user accessible surfaces)	A
Radiated Electromagnetic Field	IEC / EN 61000-4-3, 10 V/m, 1 kHz/80% Amplitude Modulation, 1 μ s Pulse Modulation, 10 kHz...2 GHz	A
Burst	IEC / EN 61000-4-4, level 3 AC port ± 2 kV, 1 minute DC port ± 1 kV, 1 minute	A
Surge	IEC / EN 61000-4-5 Line to earth: level 3, ± 2 kV Line to line: level 2, ± 1 kV	A
RF Conducted Immunity	IEC/EN 61000-4-6, Level 3, 10 Vrms, CW, 0.1 ... 80 MHz	A
Voltage Dips and Interruptions (per module)	IEC/EN 61000-4-11 (per module) 1: V_i 230 VAC, 100% Load, Dip 100%, Duration 12 ms 2: V_i 230 VAC, 100% Load, Dip 100%, Duration < 150 ms 3: V_i 230 VAC, 100% Load, Dip 100%, Duration > 150 ms	A V1: B, VSB: A B

9. ENVIRONMENTAL SPECIFICATIONS

PARAMETER	DESCRIPTION / CONDITION	MIN	NOM	MAX	UNIT
Operating Temperature	@ full load, up to 4000 m:	0		+35	°C
	@ full load, up to 1800 m:	0		+45	
	@ 75% load, up to 1800 m:	0		+55	
Non-Operating Temperature		-40		+70	°C
Humidity	Operating: @ at 40 °C, non-condensing	7		93	%RH
	Non-Operating: non-condensing	5		95	
Altitude	Operating:			4000	m
	Non-Operating:			13000	
Shock	Operating: 11 ms half-sine shocks in Z axis 10+ve, 10-ve		5		g
	Non-Operating: 11 ms half-sine shocks in Z axis 10+ve, 10-ve		30		
Vibration	Operating: 0.2 g_{rms} random	5		500	Hz
	Non-Operating: 1 g_{rms} random	2		200	
Acoustic Noise Emissions	@ normal operation, and 50% load sharing			TBD	dBA
	Fan speed			TBD	
Cooling	When equipped with operating PSUs			50	Pa

10. MECHANICAL SPECIFICATIONS

PARAMETER	SPSTET4-01
Dimensions (W x H x D)	534.5 x 46.5 x 600 (overall: 436.5 x 47 x 710 mm)
Weight (Shelf only)	9 kg
Weight (6 PSU installed)	25 kg

10.1 CONNECTORS

DESCRIPTION	REFERENCE DESIGNATOR	TYPE	MANUFACTURER	MPN
Input Connector	J106, J107	3-phase input	Positronic Industries	SP5YYE48M0LN9A1/AA-PA1067
Logic Signal Connector	J15	RJ11	Bel Fuse Inc.	SS-6444-NF
+12VSB output connector	J23		Molex	39-30-0040
CAN Connector	J13	Dual port D-SUB 9	Norcomp	189-009-413R571
Auxiliary AC Outlet	J123	Single phase output	Molex	172043-0302
Auxiliary AC Outlet	J124, J125	Single phase output	Rong Feng	RF-203P-HP-A-1.0
Auxiliary AC Outlet Fuse	F123	5 x 20 mm Time Lag Fuse	Bel Fuse Inc. Eaton	0ADKC9100-BE BK1-S505H-10-R
Auxiliary AC Outlet Fuse	F124, F125	6.3 x 32 mm Fast-Acting Fuse	Bel Fuse Inc. Littelfuse Inc.	0ADEC9150-BE 0505015.MXP

SHELF

HIGH VOLTAGE CONNECTOR PIN ASSIGNMENT

3-Phase Input Connector
(J106, J107)

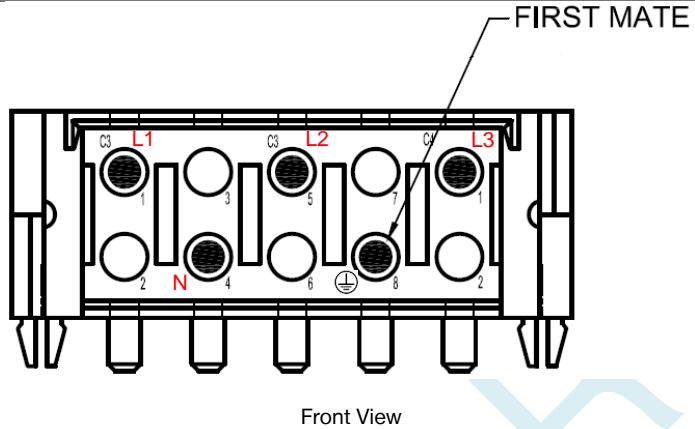

Front View

MPN

SP5YYE48M0LN9A1/AA-PA1067

Mating Part

SP5YYE1F0091/AA

Auxiliary AC Outlet
(J123)

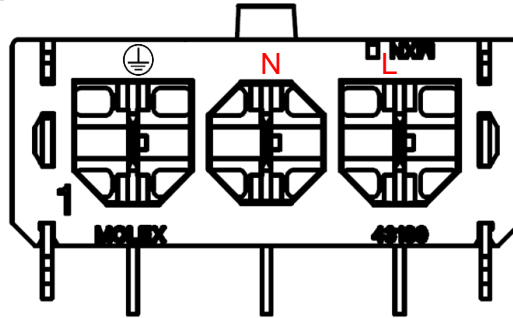

Front View

MPN

172043-0302

Mating Part

172672-2003

Auxiliary AC Outlet
(J124, J125)

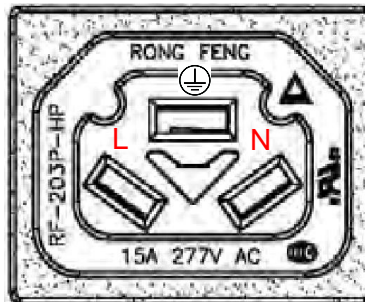

Front View

MPN

RF-203P-HP-A-1.0

10.2 SPSTET4-01 MECHANICAL DATA: (Note: finished good may look different from images.)

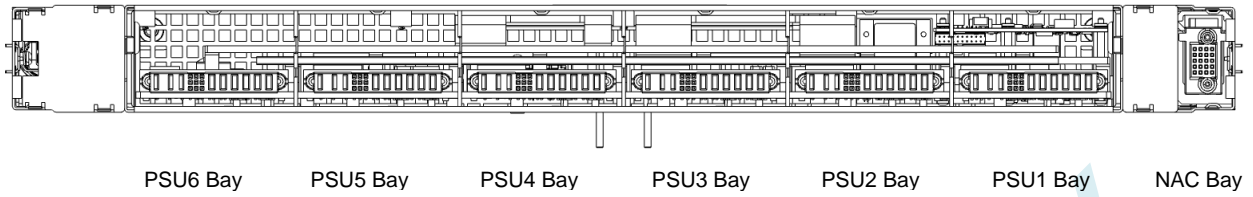

Figure 3. SPSTET4-01 Front View

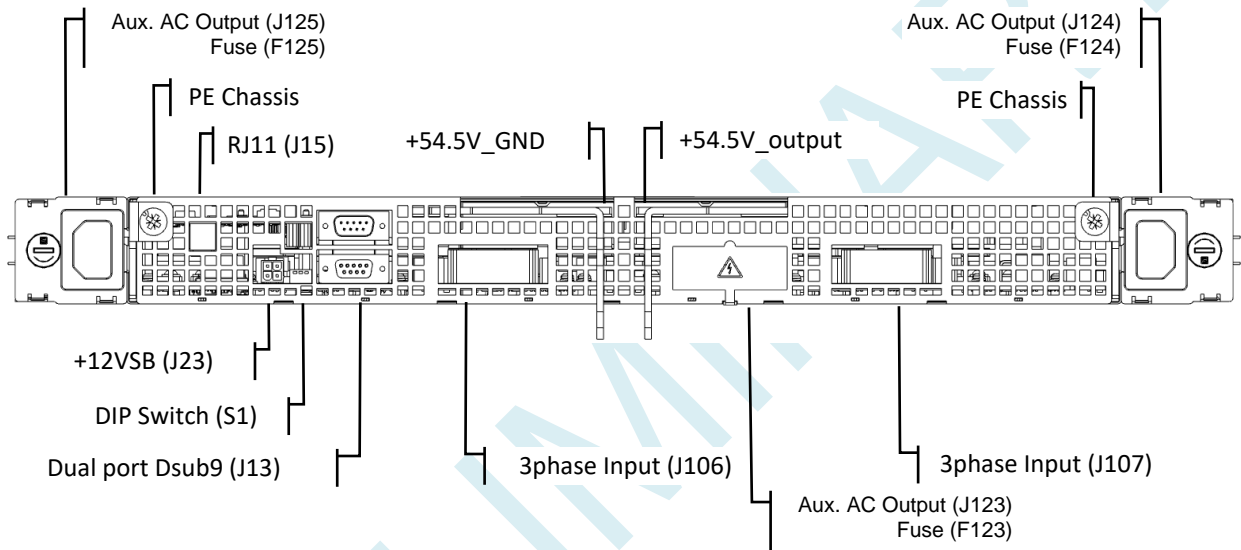

Figure 4. SPSTET4-01 Rear View

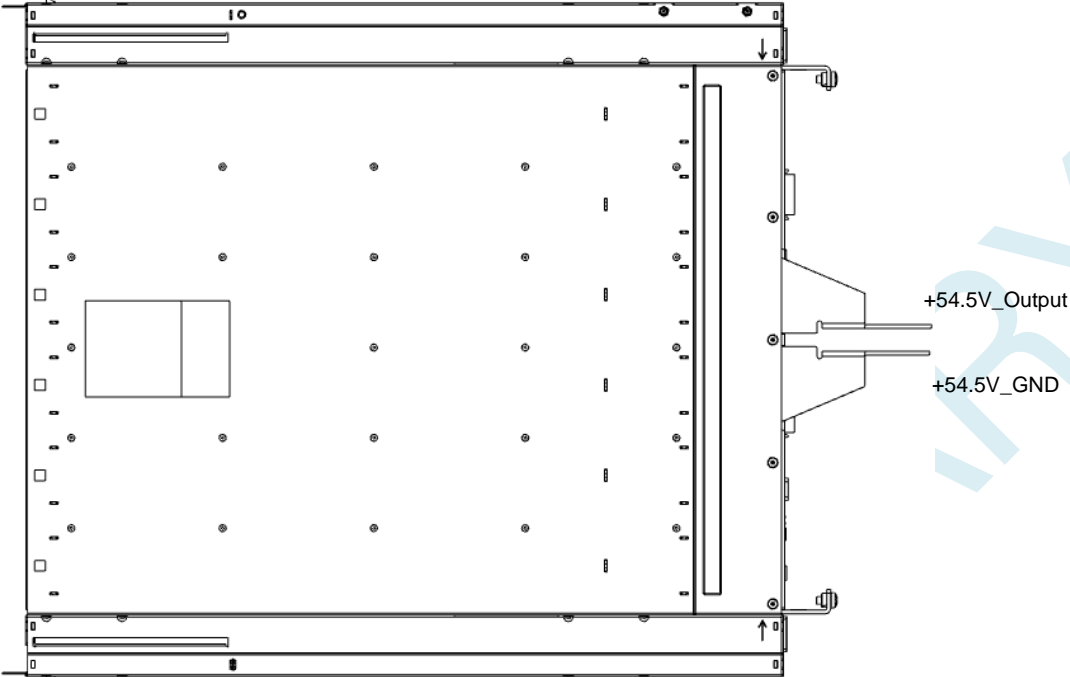

Figure 5. SPSTET4-01 Top View

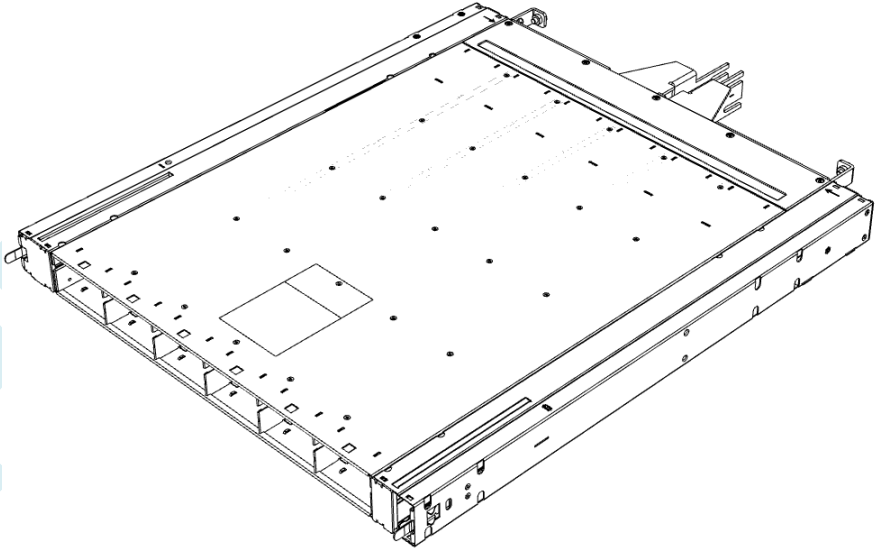



Figure 6. SPSTET4-01 Isometric View

11. ACCESSORIES

ITEM	DESCRIPTION	ORDERING PN	SOURCE
	I ² C Utility Windows Vista/7/8 compatible GUI to program, control and monitor PFE Front-Ends (and other I ² C units)	N/A	belfuse.com/power-solutions

12. REVISION HISTORY

REV	DESCRIPTION	PRODUCT VERSION	DATE	AUTHOR
001	Initial Draft	V001	27.05.2018	GS

For more information on these products consult: tech.support@psbel.com

NUCLEAR AND MEDICAL APPLICATIONS - Products are not designed or intended for use as critical components in life support systems, equipment used in hazardous environments, or nuclear control systems.

TECHNICAL REVISIONS - The appearance of products, including safety agency certifications pictured on labels, may change depending on the date manufactured. Specifications are subject to change without notice.



Asia-Pacific	Europe, Middle East	North America
+86 755 298 85888	+353 61 225 977	+1 408 785 5200

Компания «Life Electronics» занимается поставками электронных компонентов импортного и отечественного производства от производителей и со складов крупных дистрибьюторов Европы, Америки и Азии.

С конца 2013 года компания активно расширяет линейку поставок компонентов по направлению коаксиальный кабель, кварцевые генераторы и конденсаторы (керамические, пленочные, электролитические), за счёт заключения дистрибьюторских договоров

Мы предлагаем:

- Конкурентоспособные цены и скидки постоянным клиентам.
- Специальные условия для постоянных клиентов.
- Подбор аналогов.
- Поставку компонентов в любых объемах, удовлетворяющих вашим потребностям.
- Приемлемые сроки поставки, возможна ускоренная поставка.
- Доставку товара в любую точку России и стран СНГ.
- Комплексную поставку.
- Работу по проектам и поставку образцов.
- Формирование склада под заказчика.
- Сертификаты соответствия на поставляемую продукцию (по желанию клиента).
- Тестирование поставляемой продукции.
- Поставку компонентов, требующих военную и космическую приемку.
- Входной контроль качества.
- Наличие сертификата ISO.

В составе нашей компании организован Конструкторский отдел, призванный помогать разработчикам, и инженерам.

Конструкторский отдел помогает осуществить:

- Регистрацию проекта у производителя компонентов.
- Техническую поддержку проекта.
- Защиту от снятия компонента с производства.
- Оценку стоимости проекта по компонентам.
- Изготовление тестовой платы монтаж и пусконаладочные работы.



Тел: +7 (812) 336 43 04 (многоканальный)

Email: org@lifeelectronics.ru