

**16-Bit, 2-Port, Low Voltage  
Translator Bus Switch**
**Product Features**

- Near zero propagation delay
- Low ON resistance switches connect inputs to outputs
- 2.5V to 3.3V Supply Voltage Operation
- 2.5V or 1.8V switching
- Packages available:
  - 40-pin, 150mil wide plastic BQSOP (B)

**Applications**

- 3.3V to 2.5V level shifting (voltage translation)
- 2.5V to 1.8V level shifting (voltage translation)

**Product Description**

Pericom Semiconductor's PI3VT series of logic circuits are produced using the Company's advanced submicron CMOS technology, achieving industry leading performance.

The PI3VT32X245, a 2.5V or 3.3V 16-bit 2-port bus switch, is designed with a low ON resistance (5 ohms). The switches are turned ON or enabled by the Bus Enable ( $\overline{BEn}$ ) input signals.

Given a 3.3V supply and an input voltage of 3.3V, the switch translates to an output voltage of 2.5V. Similarly, when operated with a 2.5V supply and given 2.5V inputs, the device translates the outputs to 1.8V.

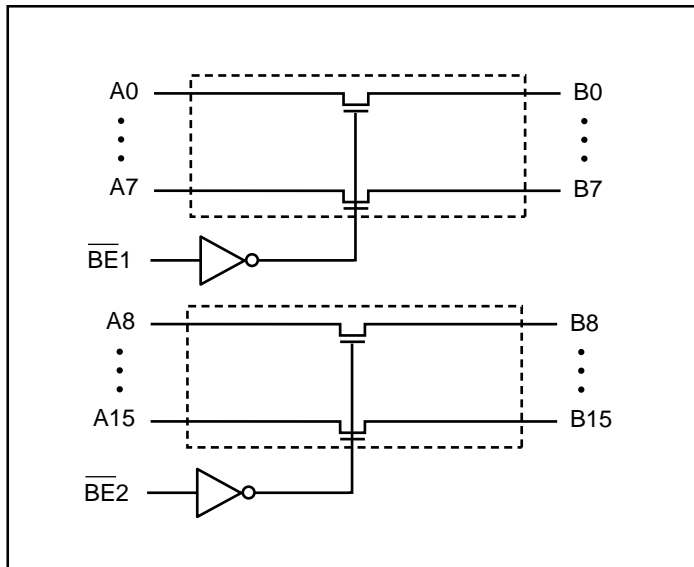
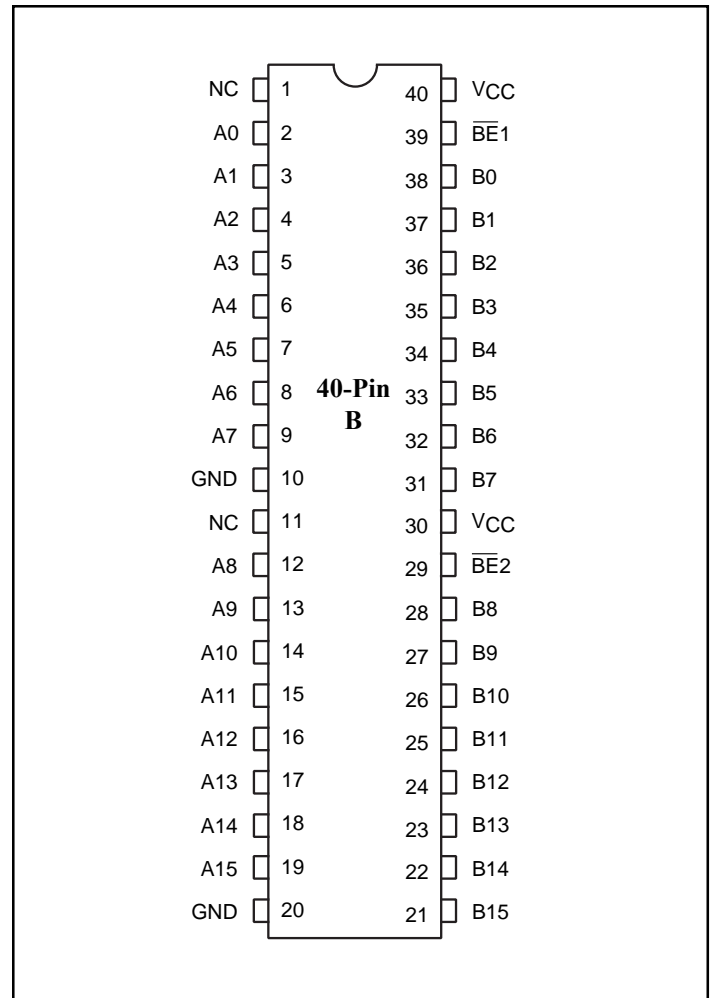
**Logic Block Diagram**

**Product Pin Configuration**

### Product Pin Description

Pin Name	I/O	Description
$\overline{\text{BEN}}$	I	Bus Enable Input (Active LOW)
A0-A15	I/O	Bus A
B0-B15	I/O	Bus B

### Truth Table<sup>(1)</sup>

Function	$\overline{\text{BEN}}$	A0-15
Disconnect	H	Hi-Z
Connect	L	B0-15

**Notes:**

- H = High Voltage Level  
 L = Low Voltage Level  
 Hi-Z = High Impedance

### Maximum Ratings

(Above which the useful life may be impaired. For user guidelines, not tested.)

Storage Temperature .....	-65°C to +150°C
Ambient Temperature with Power Applied .....	-40°C to +85°C
Supply Voltage to Ground Potential .....	-0.5V to +4.6V
DC Input Voltage .....	-0.5V to +5.5V
DC Output Current .....	120mA
Power Dissipation .....	0.5W

**Note:**

Stresses greater than those listed under MAXIMUM RATINGS may cause permanent damage to the device. This is a stress rating only and functional operation of the device at these or any other conditions above those indicated in the operational sections of this specification is not implied. Exposure to absolute maximum rating conditions for extended periods may affect reliability.

### DC Electrical Characteristics (Over Operating Range, $T_A = -40^\circ\text{C}$ to $+85^\circ\text{C}$ , $V_{CC} = 3.3\text{V} \pm 10\%$ )

Parameters	Description	Test Conditions <sup>(1)</sup>	Min.	Typ. <sup>(2)</sup>	Max.	Units
$V_{IH}$	Input HIGH Voltage	Guaranteed Logic HIGH Level	1.8		$V_{CC} + 0.3\text{V}$	V
$V_{IL}$	Input LOW Voltage	Guaranteed Logic LOW Level	-0.5		0.8	
$V_{IH}$	Input HIGH Voltage	$V_{CC} = 2.5\text{V}$	1.6		$V_{CC} + 0.3\text{V}$	
$V_{IL}$	Input LOW Voltage	$V_{CC} = 2.5\text{V}$	-0.5		0.6	
$I_{IH}$	Input HIGH Current	$V_{CC} = \text{Max.}, V_{IN} = V_{CC}$			$\pm 1$	$\mu\text{A}$
$I_{IL}$	Input LOW Current	$V_{CC} = \text{Max.}, V_{IN} = \text{GND}$			$\pm 1$	
$I_{OZH}$	High Impedance Output Current	$0 \leq A, B \leq V_{CC}$			$\pm 1$	
$R_{ON}$	Switch On Resistance	$V_{CC} = \text{Min.}, V_{IN} = 0.0\text{V}, I_{ON} = -8\text{mA}$		5	8	$\Omega$
		$V_{CC} = \text{Min.}, V_{IN} = 1.7\text{V}, I_{ON} = -8\text{mA}$		10	22	
		$V_{CC} = 2.3\text{V}, V_{IN} = 0.0\text{V}, I_{ON} = -8\text{mA}$		6	9	
		$V_{CC} = 2.3\text{V}, V_{IN} = 1.3\text{V}, I_{ON} = -8\text{mA}$		25	30	
$V_P$	Pass Voltage	$V_{IN} = V_{CC} = 3.3\text{V}, I_{OUT} = -5\mu\text{A}$	2.3	2.5	2.9	V
		$V_{IN} = V_{CC} = 2.5\text{V}, I_{OUT} = -5\mu\text{A}$		1.8		

**Capacitance** ( $T_A = 25^\circ\text{C}$ ,  $f = 1\text{ MHz}$ )

Parameters <sup>(5)</sup>	Description	Test Conditions	Typ.	Units
$C_{IN}$	Input Capacitance	$V_{IN} = 0\text{V}$	3.5	pF
$C_{OFF}$	A/B Capacitance, Switch Off		5.0	
$C_{ON}$	A/B Capacitance, Switch On		10.0	

**Notes:**

1. For Max. or Min. conditions, use appropriate value specified under Electrical Characteristics for the applicable device type.
2. Typical values are at  $V_{CC} = 3.3\text{V}$ ,  $T_A = 25^\circ\text{C}$  ambient and maximum loading.
3. Not more than one output should be shorted at one time. Duration of the test should not exceed one second.
4. Measured by the voltage drop between A and B pin at indicated current through the switch. ON resistance is determined by the lower of the voltages on the two (A,B) pins.
5. This parameter is determined by device characterization but is not production tested.

**Power Supply Characteristics**

Parameters	Description	Test Conditions <sup>(1)</sup>		Min.	Typ. <sup>(2)</sup>	Max.	Units
$I_{CC}$	Quiescent Power Supply Current	$V_{CC} = \text{Max.}$	$V_{IN} = \text{GND or } V_{CC}$			6	$\mu\text{A}$
$\Delta I_{CC}$	Quiescent Current per Input HIGH		$V_{IN} = 3\text{V}^{(3)}$			50	

**Notes:**

1. For Max. or Min. conditions, use appropriate value specified under Electrical Characteristics for the applicable device.
2. Typical values are at  $V_{CC} = 3.3\text{V}$ ,  $+25^\circ\text{C}$  ambient.
3. Per driven input (control input only); A and B pins do not contribute to  $\Delta I_{CC}$ .

**Switching Characteristics over  $3.3\text{V} \pm 0.3\text{V}$  Operating Range**

Parameters	Description	Condition <sup>(1)</sup>	Com		Units
			Min.	Max.	
$t_{PLH}$ $t_{PHL}$	Propagation Delay <sup>(2,3)</sup> Ax to Bx	$C_L = 50\text{pF}$ , $R_L = 500\text{ ohms}$		0.25	ns
$t_{PZH}$ $t_{PZL}$	Bus Enable Time BE to Ax or Bx	$C_L = 50\text{pF}$ , $R_L = 500\text{ ohms}$	1.5	6.5	
$t_{PHZ}$ $t_{PLZ}$	Bus Disable Time BE to Ax or Bx		$R = 500\text{ ohms}$	1.5	

**Switching Characteristics over 2.5V ±0.2V Operating Range**

Parameters	Description	Condition <sup>(1)</sup>	Com		Units
			Min.	Max.	
t <sub>PLH</sub> t <sub>PHL</sub>	Propagation Delay <sup>(2,3)</sup> Ax to Bx	C <sub>L</sub> = 50pF, R <sub>L</sub> = 500 ohms		0.25	ns
t <sub>PZH</sub> t <sub>PZL</sub>	Bus Enable Time BE to Ax or Bx	C <sub>L</sub> = 50pF, R <sub>L</sub> = 500 ohms	1.5	9.8	
t <sub>PHZ</sub> t <sub>PLZ</sub>	Bus Disable Time BE to Ax or Bx	R = 500 ohms	1.5	8.3	

**Notes:**

1. See test circuit and waveforms.
2. This parameter is guaranteed but not tested on Propagation Delays.
3. The bus switch contributes no propagational delay other than the RC delay of the ON resistance of the switch and the load capacitance. The time constant for the switch alone is of the order of 0.25ns for 50pF load. Since this time constant is much smaller than the rise/fall times of typical driving signals, it adds very little propagational delay to the system. Propagational delay of the bus switch when used in a system is determined by the driving circuit on the driving side of the switch and its interaction with the load on the driven side.

**Packaging Mechanical: 40-pin BQSO (B)**

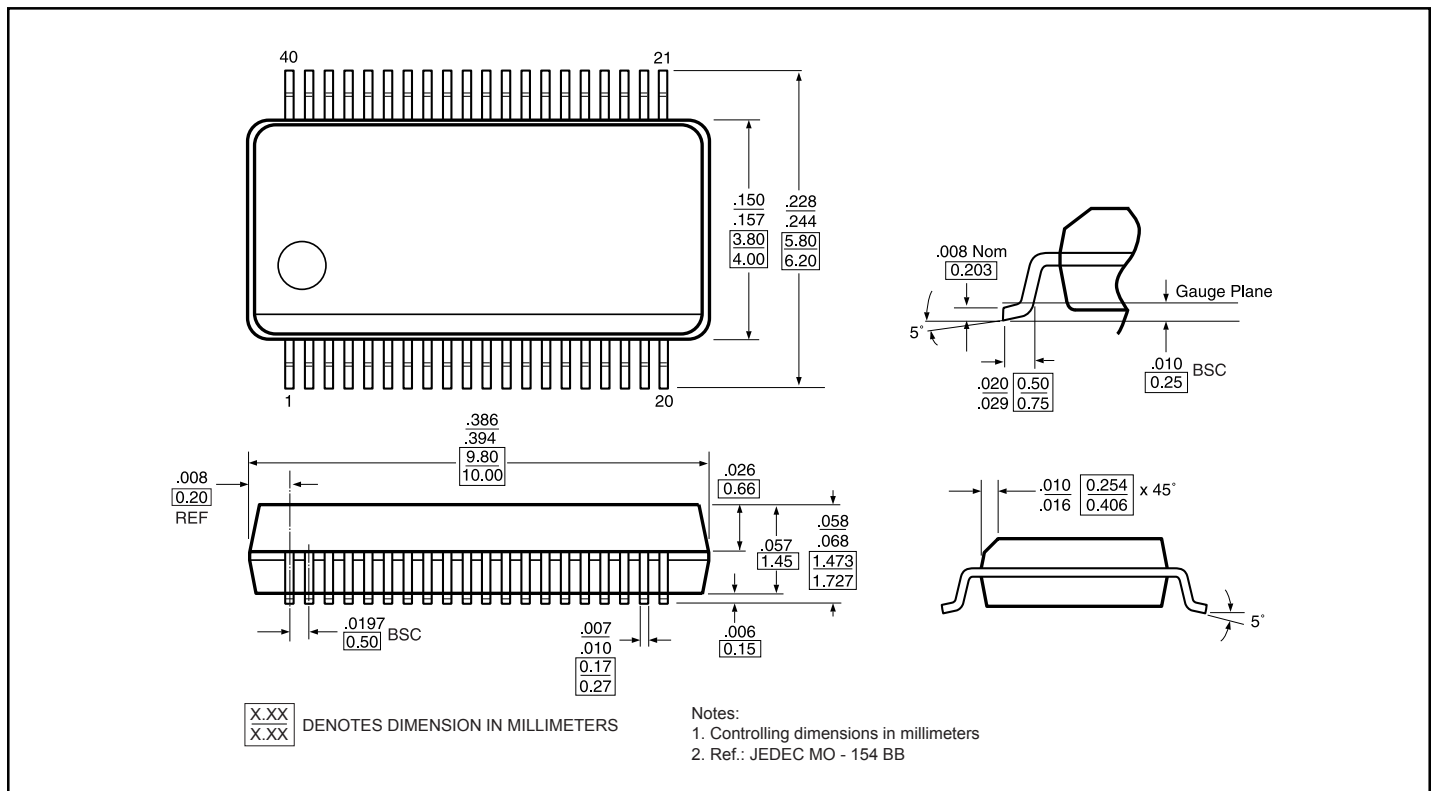

**Ordering Information**

Ordering Code	Packaging Code	Package Type
PI3VT32X245B	B	40-BQSOP

# Mouser Electronics

Authorized Distributor

Click to View Pricing, Inventory, Delivery & Lifecycle Information:

[Diodes Incorporated:](#)

[PI3VT32X245BE](#) [PI3VT32X245BEX](#)

Компания «Life Electronics» занимается поставками электронных компонентов импортного и отечественного производства от производителей и со складов крупных дистрибьюторов Европы, Америки и Азии.

С конца 2013 года компания активно расширяет линейку поставок компонентов по направлению коаксиальный кабель, кварцевые генераторы и конденсаторы (керамические, пленочные, электролитические), за счёт заключения дистрибьюторских договоров

Мы предлагаем:

- Конкурентоспособные цены и скидки постоянным клиентам.
- Специальные условия для постоянных клиентов.
- Подбор аналогов.
- Поставку компонентов в любых объемах, удовлетворяющих вашим потребностям.
- Приемлемые сроки поставки, возможна ускоренная поставка.
- Доставку товара в любую точку России и стран СНГ.
- Комплексную поставку.
- Работу по проектам и поставку образцов.
- Формирование склада под заказчика.
- Сертификаты соответствия на поставляемую продукцию (по желанию клиента).
- Тестирование поставляемой продукции.
- Поставку компонентов, требующих военную и космическую приемку.
- Входной контроль качества.
- Наличие сертификата ISO.

В составе нашей компании организован Конструкторский отдел, призванный помогать разработчикам, и инженерам.

Конструкторский отдел помогает осуществить:

- Регистрацию проекта у производителя компонентов.
- Техническую поддержку проекта.
- Защиту от снятия компонента с производства.
- Оценку стоимости проекта по компонентам.
- Изготовление тестовой платы монтаж и пусконаладочные работы.



Тел: +7 (812) 336 43 04 (многоканальный)

Email: [org@lifeelectronics.ru](mailto:org@lifeelectronics.ru)