

### Description

The 9DML0441 / 9DML0451 devices are 3.3V members of IDT's Full-Featured PCIe family. They support PCIe Gen1-4 Common Clocked (CC), Separate Reference no Spread (SRnS), and Separate Reference Independent Spread (SRIS) architectures. The parts provide a choice of asynchronous and glitch-free switching modes, and offer a choice of integrated output terminations for direct connection to 85Ω or 100Ω transmission lines. The 9DML04P1 can be factory programmed with a user-defined power-up default configuration.

### Typical Applications

Servers, ATCA, ATE, Storage, Master/Slave applications

### Output Features

- Four 1–200MHz Low-Power HCSL (LP-HCSL) DIF pairs
  - 9DML0441 default Z<sub>OUT</sub> = 100Ω
  - 9DML0451 default Z<sub>OUT</sub> = 85Ω
  - 9DML04P1 factory programmable defaults
- See [AN-891](#) for easy termination to other logic levels

### Features

- Direct connection to 100Ω (xx41) or 85Ω (xx51) transmission lines saves up to 16 resistors
- 79mW typical power consumption
- Spread Spectrum (SS) compatible
- Factory programmed P1 device allows exact optimization to customer requirements:
  - Control input polarity
  - Control input pull up/downs
  - Slew rate for each output
  - Differential output amplitude
  - Output impedance for each output
- OE# pins for each output
- HCSL-compatible differential inputs; can be driven by common clock source
- Selectable asynchronous or glitch-free switching; allows the mux to be selected at power-up even if both inputs are not running, then transition to glitch-free switching mode
- Space saving 4 × 4 mm 24-VFQFPN

### Key Specifications

- PCIe Gen1–4 CC compliant
- PCIe Gen2–3 SRIS compliant
- Output-to-output skew < 50ps
- PCIe Gen4 additive phase jitter is < 0.1 ps rms
- 12kHz–20MHz additive phase jitter 285fs rms typical at 156.25MHz

### Block Diagram

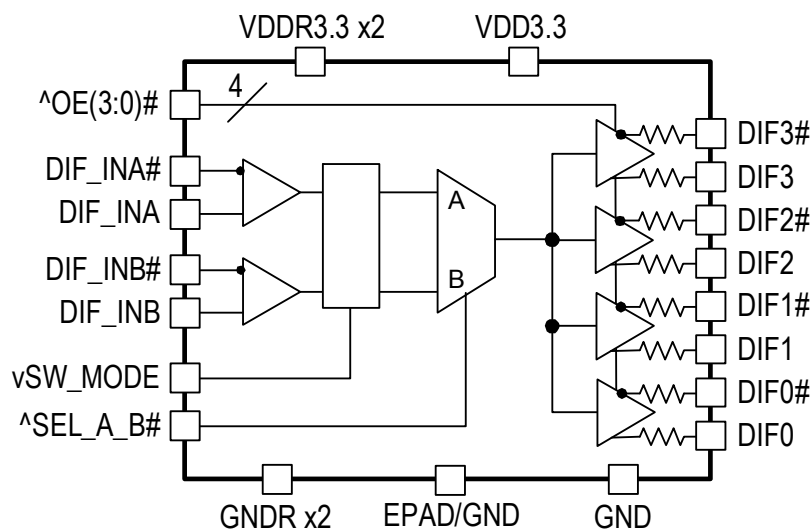

**Note:** Resistors default to internal on xx41/xx51 devices. P1 devices have programmable default impedances on an output-by-output basis.

## Pin Configuration

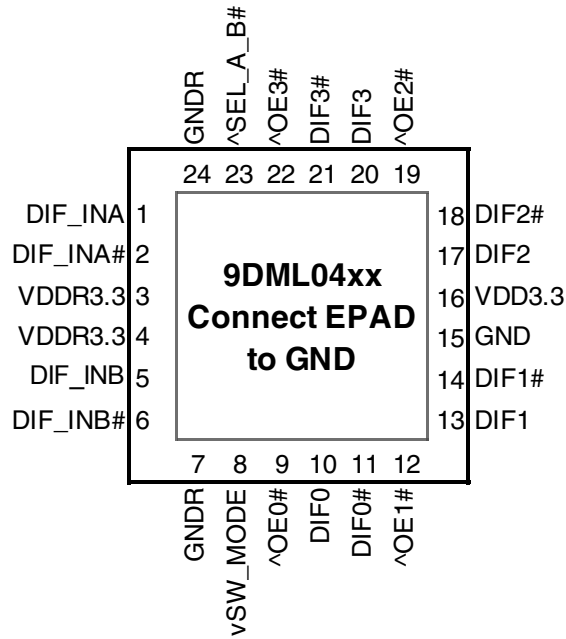

### 24-VFQFPN, 4 x 4 mm, 0.5mm pitch

^ prefix indicates internal pull-up resistor  
 v prefix indicates internal pull-down resistor

### Power Management Table

OEx# Pin	DIF_IN	DIFx	
		True O/P	Comp. O/P
0	Running	Running	Running
1	Running	Low	Low

### Power Connections

Pin Number		Description
VDD	GND	
3	24	Input A receiver analog
4	7	Input B receiver analog
16	15	DIF outputs

## Pin Descriptions

Pin#	Pin Name	Type	Pin Description
1	DIF_INA	IN	HCSL Differential True input
2	DIF_INA#	IN	HCSL Differential Complement Input
3	VDDR3.3	PWR	3.3V power for differential input clock (receiver). This VDD should be treated as an Analog power rail and filtered appropriately.
4	VDDR3.3	PWR	3.3V power for differential input clock (receiver). This VDD should be treated as an Analog power rail and filtered appropriately.
5	DIF_INB	IN	HCSL Differential True input
6	DIF_INB#	IN	HCSL Differential Complement Input
7	GNDR	GND	Analog Ground pin for the differential input (receiver)
8	vSW_MODE	IN	Switch Mode. This pin selects either asynchronous or glitch-free switching of the mux. Use asynchronous mode if 0 or 1 of the input clocks is running. Use glitch-free mode if both input clocks are running. This pin has an internal pull down resistor of ~120kohms. 0 = asynchronous mode 1 = glitch-free mode
9	^OE0#	IN	Active low input for enabling DIF pair 0. This pin has an internal pull-up resistor. 1 =disable outputs, 0 = enable outputs
10	DIF0	OUT	Differential true clock output
11	DIF0#	OUT	Differential Complementary clock output
12	^OE1#	IN	Active low input for enabling DIF pair 1. This pin has an internal pull-up resistor. 1 =disable outputs, 0 = enable outputs
13	DIF1	OUT	Differential true clock output
14	DIF1#	OUT	Differential Complementary clock output
15	GND	GND	Ground pin.
16	VDD3.3	PWR	Power supply, nominal 3.3V
17	DIF2	OUT	Differential true clock output
18	DIF2#	OUT	Differential Complementary clock output
19	^OE2#	IN	Active low input for enabling DIF pair 2. This pin has an internal pull-up resistor. 1 =disable outputs, 0 = enable outputs
20	DIF3	OUT	Differential true clock output
21	DIF3#	OUT	Differential Complementary clock output
22	^OE3#	IN	Active low input for enabling DIF pair 3. This pin has an internal pull-up resistor. 1 =disable outputs, 0 = enable outputs
23	^SEL_A_B#	IN	Input to select differential input clock A or differential input clock B. This input has an internal pull-up resistor. 0 = Input B selected, 1 = Input A selected.
24	GNDR	GND	Analog Ground pin for the differential input (receiver)
25	EPAD	GND	Connect to Ground.

## Test Loads

Low-Power HCSL Differential Output Test Load

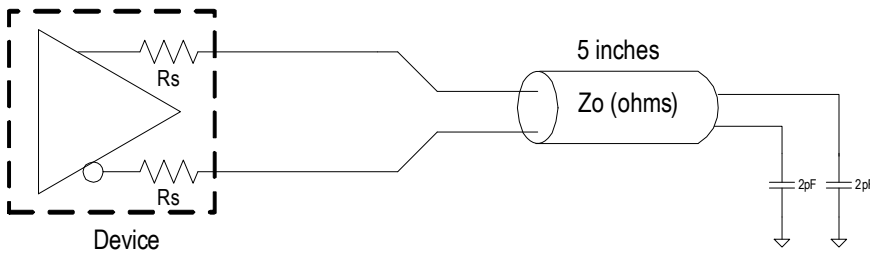

### Terminations

Device	Zo ( $\Omega$ )	Rs ( $\Omega$ )
9DML0441	100	None needed
9DML0451	100	7.5
9DML04P1	100	Prog.
9DML0441	85	N/A
9DML0451	85	None needed
9DML04P1	85	Prog.

## Alternate Terminations

The 9DML family can easily drive LVPECL, LVDS, and CML logic. See [“AN-891 Driving LVPECL, LVDS, and CML Logic with IDT's "Universal" Low-Power HCSL Outputs”](#) for details.

## Absolute Maximum Ratings

Stresses above the ratings listed below can cause permanent damage to the 9DML0441 / 9DML0451. These ratings, which are standard values for IDT commercially rated parts, are stress ratings only. Functional operation of the device at these or any other conditions above those indicated in the operational sections of the specifications is not implied. Exposure to absolute maximum rating conditions for extended periods can affect product reliability. Electrical parameters are guaranteed only over the recommended operating temperature range.

Parameter	Symbol	Conditions	Minimum	Typical	Maximum	Units	Notes
Supply Voltage	VDDx				4.6	V	1,2
Input Voltage	V <sub>IN</sub>		-0.5		V <sub>DD</sub> +0.5	V	1,3
Input High Voltage, SMBus	V <sub>IHSMB</sub>	SMBus clock and data pins			3.9	V	1
Storage Temperature	T <sub>s</sub>		-65		150	°C	1
Junction Temperature	T <sub>j</sub>				125	°C	1
Input ESD protection	ESD prot	Human Body Model	2500			V	1

<sup>1</sup>Guaranteed by design and characterization, not 100% tested in production.

<sup>2</sup>Operation under these Conditions is neither implied nor guaranteed.

<sup>3</sup>Not to exceed 4.6V.

## Electrical Characteristics—Clock Input Parameters

T<sub>A</sub> = T<sub>AMB</sub>, Supply Voltages per normal operation Conditions, See Test Loads for Loading Conditions

Parameter	Symbol	Conditions	Minimum	Typical	Maximum	Units	Notes
Input Common Mode Voltage - DIF_IN	V <sub>COM</sub>	Common Mode Input Voltage	150		900	mV	1
Input Swing - DIF_IN	V <sub>SWING</sub>	Differential value	300			mV	1
Input Slew Rate - DIF_IN	dv/dt	Measured differentially	0.4		8	V/ns	1,2
Input Leakage Current	I <sub>IN</sub>	V <sub>IN</sub> = V <sub>DD</sub> , V <sub>IN</sub> = GND	-5		5	uA	
Input Duty Cycle	d <sub>in</sub>	Measurement from differential waveform	45		55	%	1
Input Jitter - Cycle to Cycle	J <sub>DIFin</sub>	Differential Measurement	0		125	ps	1

<sup>1</sup>Guaranteed by design and characterization, not 100% tested in production.

<sup>2</sup>Slew rate measured through +/-75mV window centered around differential zero.

## Electrical Characteristics–Current Consumption

$T_A = T_{AMB}$ , Supply Voltages per normal operation Conditions, See Test Loads for Loading Conditions

Parameter	Symbol	Conditions	Minimum	Typical	Maximum	Units	Notes
Operating Supply Current	$I_{DD}$	VDD, All outputs active at 100MHz		24	31	mA	
Powerdown Current	$I_{DDPD}$	VDD, all outputs disabled		2	3	mA	1

<sup>1</sup> Input clock stopped.

## Electrical Characteristics–Input/Supply/Common Parameters–Normal Operating Conditions

$T_A = T_{AMB}$ , Supply Voltages per normal operation Conditions, See Test Loads for Loading Conditions

Parameter	Symbol	Conditions	Minimum	Typical	Maximum	Units	Notes
Supply Voltage	VDDx	Supply voltage for core and analog	3.135	3.3	3.465	V	
Ambient Operating Temperature	$T_{AMB}$	Industrial range	-40	25	85	°C	
Input High Voltage	$V_{IH}$	Single-ended inputs, except SMBus	$0.75 V_{DD}$		$V_{DD} + 0.3$	V	
Input Low Voltage	$V_{IL}$	Single-ended inputs, except SMBus	-0.3		$0.25 V_{DD}$	V	
Input Current	$I_{IN}$	Single-ended inputs, $V_{IN} = GND$ , $V_{IN} = V_{DD}$	-5		5	uA	
	$I_{INP}$	Single-ended inputs $V_{IN} = 0$ V; Inputs with internal pull-up resistors $V_{IN} = V_{DD}$ ; Inputs with internal pull-down resistors	-50		50	uA	
Input Frequency	$F_{ibyp}$		1		200	MHz	2
Pin Inductance	$L_{pin}$				7	nH	1
Capacitance	$C_{IN}$	Logic Inputs, except DIF_IN	1.5		5	pF	1
	$C_{INDIF\_IN}$	DIF_IN differential clock inputs	1.5		2.7	pF	1
	$C_{OUT}$	Output pin capacitance			6	pF	1
Clk Stabilization	$T_{STAB}$	From $V_{DD}$ Power-Up and after input clock stabilization or de-assertion of PD# to 1st clock		0.74	1	ms	1,2
Input SS Modulation Frequency PCIe	$f_{MODINPCIe}$	Allowable Frequency for PCIe Applications (Triangular Modulation)	30	31.5	33	kHz	
Input SS Modulation Frequency non-PCIe	$f_{MODIN}$	Allowable Frequency for non-PCIe Applications (Triangular Modulation)	0		66	kHz	
OE# Latency	$t_{LATOE\#}$	DIF start after OE# assertion DIF stop after OE# deassertion	1	2	3	clocks	1,3
Tfall	$t_f$	Fall time of single-ended control inputs			5	ns	2
Trise	$t_r$	Rise time of single-ended control inputs			5	ns	2

<sup>1</sup> Guaranteed by design and characterization, not 100% tested in production.

<sup>2</sup> Control input must be monotonic from 20% to 80% of input swing.

<sup>3</sup> Time from deassertion until outputs are > 200 mV.

## Electrical Characteristics–DIF Low-Power HCSL Outputs

$T_A = T_{AMB}$ , Supply Voltages per normal operation Conditions, See Test Loads for Loading Conditions

Parameter	Symbol	Conditions	Minimum	Typical	Maximum	Units	Notes
Slew rate	dV/dt	Scope averaging on, default settings	1.5	2.4	4	V/ns	1, 2, 3
Slew rate matching	$\Delta dV/dt$	Slew rate matching		8.1	20	%	1, 4
Voltage High	$V_{HIGH}$	Statistical measurement on single-ended signal using oscilloscope math function. (Scope averaging on)	660	783	850	mV	7
Voltage Low	$V_{LOW}$		-150	-24	150		7
Maximum Voltage	$V_{Maximum}$	Measurement on single ended signal using absolute value. (Scope averaging off)		814	1150	mV	7
Minimum Voltage	$V_{Minimum}$		-300	-66			7
Crossing Voltage (abs)	$V_{cross\_abs}$	Scope averaging off	250	368	550	mV	1, 5
Crossing Voltage (var)	$\Delta-V_{cross}$	Scope averaging off		17	140	mV	1, 6

<sup>1</sup>Guaranteed by design and characterization, not 100% tested in production.

<sup>2</sup>Measured from differential waveform

<sup>3</sup>Slew rate is measured through the  $V_{swing}$  voltage range centered around differential 0V. This results in a +/-150mV window around differential 0V. These are defaults for the 41/51 devices, alternate settings are available in the P1 device.

<sup>4</sup>Matching applies to rising edge rate for Clock and falling edge rate for Clock#. It is measured using a +/-75mV window centered on the average cross point where Clock rising meets Clock# falling. The median cross point is used to calculate the voltage thresholds the oscilloscope is to use for the edge rate calculations.

<sup>5</sup> $V_{cross}$  is defined as voltage where Clock = Clock# measured on a component test board and only applies to the differential rising edge (i.e. Clock rising and Clock# falling).

<sup>6</sup>The total variation of all  $V_{cross}$  measurements in any particular system. Note that this is a subset of  $V_{cross\_Minimum/Maximum}$  ( $V_{cross}$  absolute) allowed. The intent is to limit  $V_{cross}$  induced modulation by setting  $\Delta-V_{cross}$  to be smaller than  $V_{cross}$  absolute.

<sup>7</sup>These are defaults for the 41/51 devices. They are factory adjustable in the P1 device.

## Electrical Characteristics–Output Duty Cycle, Jitter, Skew and PLL Characteristics

$T_A = T_{AMB}$ , Supply Voltages per normal operation Conditions, See Test Loads for Loading Conditions

Parameter	Symbol	Conditions	Minimum	Typical	Maximum	Units	Notes
Duty Cycle Distortion	$t_{DCD}$	Measured differentially, at 100MHz	0	0.2	0.7	%	1,3
Skew, Input to Output	$t_{pd}$	$V_T = 50\%$	2637	3381	4273	ps	1
Skew, Output to Output	$t_{sk3}$	$V_T = 50\%$		23	50	ps	1
Jitter, Cycle to cycle	$t_{cyc-cyc}$	Additive Jitter in Bypass Mode			1	ps	1,2

<sup>1</sup>Guaranteed by design and characterization, not 100% tested in production.

<sup>2</sup>Measured from differential waveform.

<sup>3</sup>Duty cycle distortion is the difference in duty cycle between the output and the input clock.

## Electrical Characteristics—Filtered Phase Jitter Parameters - PCIe Common Clocked (CC) Architectures

T<sub>AMB</sub> = over the specified operating range. Supply Voltages per normal operation Conditions, See Test Loads for Loading Conditions

Parameter	Symbol	Conditions	Minimum	Typical	Maximum	Industry Limit	Units	Notes
Additive Phase Jitter	t <sub>jphPCIeG1-CC</sub>	PCIe Gen 1		1.5	5	n/a	ps (p-p)	1,2,3,5
	t <sub>jphPCIeG2-CC</sub>	PCIe Gen 2 Lo Band 10kHz < f < 1.5MHz (PLL BW of 5-16MHz or 8-5MHz, CDR = 5MHz)		0.01	0.10		ps (rms)	1,2,4,5
		PCIe Gen 2 High Band 1.5MHz < f < Nyquist (50MHz) (PLL BW of 5-16MHz or 8-5MHz, CDR = 5MHz)		0.16	0.21		ps (rms)	1,2,4,5
	t <sub>jphPCIeG3-CC</sub>	PCIe Gen 3 (PLL BW of 2-4MHz or 2-5MHz, CDR = 10MHz)		0.07	0.10		ps (rms)	1,2,4,5
	t <sub>jphPCIeG4-CC</sub>	PCIe Gen 4 (PLL BW of 2-4MHz or 2-5MHz, CDR = 10MHz)		0.07	0.10		ps (rms)	1,2,4,5

<sup>1</sup> Applies to all outputs.

<sup>2</sup> Based on PCIe Base Specification Rev4.0 version 1.0. See <http://www.pcisig.com> for latest specifications.

<sup>3</sup> Sample size of at least 100K cycles. This figure extrapolates to 108ps pk-pk at 1M cycles for a BER of 1<sup>-12</sup>.

<sup>4</sup> For RMS values additive jitter is calculated by solving the following equation for b [ $a^2+b^2=c^2$ ] where "a" is rms input jitter and "c" is rms total jitter.

<sup>5</sup> Driven by 9FGL0841 or equivalent.

## Electrical Characteristics—Filtered Phase Jitter Parameters - PCIe Separate Reference Independent Spread (SRIS) Architectures<sup>5</sup>

T<sub>AMB</sub> = over the specified operating range. Supply Voltages per normal operation Conditions, See Test Loads for Loading Conditions

Parameter	Symbol	Conditions	Minimum	Typical	Maximum	Industry Limit	Units	Notes
Additive Phase Jitter	t <sub>jphPCIeG2-SRIS</sub>	PCIe Gen 2 (PLL BW of 16MHz, CDR = 5MHz)		0.21	0.26	n/a	ps (rms)	1,2,4
	t <sub>jphPCIeG3-SRIS</sub>	PCIe Gen 3 (PLL BW of 2-4MHz or 2-5MHz, CDR = 10MHz)		0.06	0.11		ps (rms)	1,2,4

<sup>1</sup> Applies to all outputs.

<sup>2</sup> Based on PCIe Base Specification Rev3.1a. These filters are different than Common Clock filters. See <http://www.pcisig.com> for latest

<sup>3</sup> Sample size of at least 100K cycles. This figure extrapolates to 108ps pk-pk at 1M cycles for a BER of 1<sup>-12</sup>.

<sup>4</sup> For RMS values, additive jitter is calculated by solving the following equation for b [ $a^2+b^2=c^2$ ] where "a" is rms input jitter and "c" is rms total jitter.

<sup>5</sup> As of PCIe Base Specification Rev4.0 v1.0, SRIS is not currently defined for Gen1 or Gen4.

## Electrical Characteristics– Unfiltered Phase Jitter Parameters

$T_A = T_{AMB}$ , Supply Voltages per normal operation Conditions, See Test Loads for Loading Conditions

Parameter	Symbol	Conditions	Minimum	Typical	Maximum	Industry Limit	Units	Notes
Additive Phase Jitter, Fanout Mode	$t_{jph156M}$	156.25MHz, 1.5MHz to 10MHz, -20dB/decade rollover < 1.5MHz, -40db/decade rolloff > 10MHz		114		n/a	fs (rms)	1,2,3
	$t_{jph156M12k-20}$	156.25MHz, 12kHz to 20MHz, -20dB/decade rollover <12kHz, -40db/decade rolloff > 20MHz		285			fs (rms)	1,2,3

<sup>1</sup> Guaranteed by design and characterization, not 100% tested in production.

<sup>2</sup> Driven by Rhode & Schwartz SMA100.

<sup>3</sup> For RMS values additive jitter is calculated by solving the following equation for b [ $a^2+b^2=c^2$ ] where "a" is rms input jitter and "c" is rms total jitter.

## Marking Diagrams



Notes:

1. "LOT" is the lot sequence number.
2. "YYWW" or "YWW" is the digits of the year and week that the part was assembled.
3. "I" denotes industrial temperature range device.
4. "P" denotes factory programmable defaults.
5. "\*\*\*" denotes the lot sequence.
6. "\$" denotes the mark code.

## Thermal Characteristics

Parameter	Symbol	Conditions	PKG	Typical VALUE	Units	Notes
Thermal Resistance	$\theta_{JC}$	Junction to Case	NLG24	42	°C/W	1
	$\theta_{Jb}$	Junction to Base		2.4	°C/W	1
	$\theta_{JA0}$	Junction to Air, still air		39	°C/W	1
	$\theta_{JA1}$	Junction to Air, 1 m/s air flow		33	°C/W	1
	$\theta_{JA3}$	Junction to Air, 3 m/s air flow		28	°C/W	1
	$\theta_{JA5}$	Junction to Air, 5 m/s air flow		27	°C/W	1

<sup>1</sup> EPAD soldered to board.



## Package Outline Drawings

The package outline drawings are appended at the end of this document and are accessible from the link below. The package information is the most current data available.

[www.idt.com/document/psc/nlnlg24p1-package-outline-40-x-40-mm-body-05-mm-pitch-qfn-epad-size-245-x-245-mm](http://www.idt.com/document/psc/nlnlg24p1-package-outline-40-x-40-mm-body-05-mm-pitch-qfn-epad-size-245-x-245-mm)

## Ordering Information

Part / Order Number	Notes	ShippingPackaging	Package	Temperature
9DML0441AKILF	100Ω	Trays	24-VFQFPN	-40 to +85° C
9DML0441AKILFT		Tape and Reel	24-VFQFPN	-40 to +85° C
9DML0451AKILF	85Ω	Trays	24-VFQFPN	-40 to +85° C
9DML0451AKILFT		Tape and Reel	24-VFQFPN	-40 to +85° C
9DML04P1AxxxKILF	Factory configurable. Contact IDT for additional information.	Trays	24-VFQFPN	-40 to +85° C
9DML04P1AxxxKILFT		Tape and Reel	24-VFQFPN	-40 to +85° C

“LF” suffix to the part number are the Pb-Free configuration and are RoHS compliant.

“A” is the device revision designator (will not correlate with the datasheet revision).

“xxx” is a unique factory assigned number to identify a particular default configuration.

---

## Revision History

Issue Date	Description	Page #
8/27/2018	1. Minor updates to electrical tables. 2. Updated front page text. 3. Updated block diagram.	Various
6/6/2016	1. Updated leakage current spec for inputs with pull/up/down to +/-50 $\mu$ A. 2. Updated electrical tables with characterization data. 3. Update Front page text. 4. Updated ordering information. 5. Move to Final.	Various



**Corporate Headquarters**  
6024 Silver Creek Valley Road  
San Jose, CA 95138 USA  
[www.IDT.com](http://www.IDT.com)

**Sales**  
1-800-345-7015 or 408-284-8200  
Fax: 408-284-2775  
[www.IDT.com/go/sales](http://www.IDT.com/go/sales)

**Tech Support**  
[www.idt.com/go/support](http://www.idt.com/go/support)

DISCLAIMER Integrated Device Technology, Inc. (IDT) and its affiliated companies (herein referred to as "IDT") reserve the right to modify the products and/or specifications described herein at any time, without notice, at IDT's sole discretion. Performance specifications and operating parameters of the described products are determined in an independent state and are not guaranteed to perform the same way when installed in customer products. The information contained herein is provided without representation or warranty of any kind, whether express or implied, including, but not limited to, the suitability of IDT's products for any particular purpose, an implied warranty of merchantability, or non-infringement of the intellectual property rights of others. This document is presented only as a guide and does not convey any license under intellectual property rights of IDT or any third parties.

IDT's products are not intended for use in applications involving extreme environmental conditions or in life support systems or similar devices where the failure or malfunction of an IDT product can be reasonably expected to significantly affect the health or safety of users. Anyone using an IDT product in such a manner does so at their own risk, absent an express, written agreement by IDT.

Integrated Device Technology, IDT and the IDT logo are trademarks or registered trademarks of IDT and its subsidiaries in the United States and other countries. Other trademarks used herein are the property of IDT or their respective third party owners. For datasheet type definitions and a glossary of common terms, visit [www.idt.com/go/glossary](http://www.idt.com/go/glossary). Integrated Device Technology, Inc. All rights reserved.

Компания «Life Electronics» занимается поставками электронных компонентов импортного и отечественного производства от производителей и со складов крупных дистрибьюторов Европы, Америки и Азии.

С конца 2013 года компания активно расширяет линейку поставок компонентов по направлению коаксиальный кабель, кварцевые генераторы и конденсаторы (керамические, пленочные, электролитические), за счёт заключения дистрибьюторских договоров

Мы предлагаем:

- Конкурентоспособные цены и скидки постоянным клиентам.
- Специальные условия для постоянных клиентов.
- Подбор аналогов.
- Поставку компонентов в любых объемах, удовлетворяющих вашим потребностям.
- Приемлемые сроки поставки, возможна ускоренная поставка.
- Доставку товара в любую точку России и стран СНГ.
- Комплексную поставку.
- Работу по проектам и поставку образцов.
- Формирование склада под заказчика.
- Сертификаты соответствия на поставляемую продукцию (по желанию клиента).
- Тестирование поставляемой продукции.
- Поставку компонентов, требующих военную и космическую приемку.
- Входной контроль качества.
- Наличие сертификата ISO.

В составе нашей компании организован Конструкторский отдел, призванный помогать разработчикам, и инженерам.

Конструкторский отдел помогает осуществить:

- Регистрацию проекта у производителя компонентов.
- Техническую поддержку проекта.
- Защиту от снятия компонента с производства.
- Оценку стоимости проекта по компонентам.
- Изготовление тестовой платы монтаж и пусконаладочные работы.



Тел: +7 (812) 336 43 04 (многоканальный)

Email: [org@lifeelectronics.ru](mailto:org@lifeelectronics.ru)