

1. Scope:**1.1 Contents**

This specification covers the requirements for product performance, test methods and quality assurance provisions of FBIS-2 Connector.

Applicable product descriptions and part numbers are as shown in Appendix 2.

2. Applicable Documents:

The following documents form a part of this specification to the extent specified herein. In the event of conflict between the requirements of this specification and the product drawing, the product drawing shall take precedence. In the event of conflict between the requirements of this specification and the referenced documents, this specification shall take precedence.

2.1 AMP Specifications :

- A.109-5000 Test Specification,
General Requirements for Test Methods.
- B.501-61056 Test Report:

2.2 Commercial Standards and Specifications:

- A. MIL-STD-202: Test Methods for Electronic and
Electrical Component Parts.
- B.EIA 364: Test Specification

3. Requirements

3.1 Design and Construction

Product shall be of the design, construction and physical dimensions specified on the applicable product drawing.

3.2 Materials

A. Contact

- Material: Copper Alloy
- Finish: Nickel-under plated all over.
Gold plated at contact area.
Gold flash plated at soldering area.

B. Housing

Thermoplastic Molding Compound
Color: Black, UL94V-0 / UL94HB

C. Solder Peg

- Material: Copper Alloy
- Finish: Nickel-under plated all over.
Tin plated all over.

3.3 Ratings

A. Voltage Rating: 30V DC

B. Current Rating: 1.5 A /Contact

C. Temperature Rating : -40°C to +85°C

High limit temperature includes raised temperature by operation.

D. Keeping Temperature : -10°C to +50°C

3.4 Performance Requirements and Test Descriptions

The product shall be designed to meet the electrical, mechanical and environmental performance requirements specified in Fig. 1. All tests shall be performed in the room temperature, unless otherwise specified.

3.5 Test Requirements and Procedures Summary

Para.	Test Items	Requirements	Procedures
3.5.1	Examination of Product	Meets requirements of product drawing.	Visual inspection No physical damage
Electrical Requirements			
3.5.2	Termination Resistance (Low Level)	30 mΩ Max. (Initial) Δ R 10mΩ Max.(Final)	<ul style="list-style-type: none"> • Subject mated contacts assembled in housing to 20 mV Max. open circuit at 100 mA. • As shown in Fig.2 • EIA 364-23
3.5.3	Dielectric withstanding Voltage (DWV)	There shall be no evidence of arc-over, insulation breakdown or leakage current in excess of 1mA	<ul style="list-style-type: none"> • 500Vrms at 60Hz, between terminals and terminals to case • 60 seconds. • The connector shall be mounted but not soldered to P.C board • The voltage shall be applied across a minimum of 50% of each of the adjacent and opposing contacts per connector • EIA 364-20
3.5.4	Insulation Resistance (I.R)	The insulation resistance of mated connectors shall not be less than 500MΩ	<ul style="list-style-type: none"> • 100V DC • 2 minutes • The connector shall be mated but not soldered to P.C board • The insulation resistance shall be measured between a minimum of 50% of each of the adjacent and opposing contacts per connector • EIA 364-21B
3.5.5	Temperature Rising	30°C Max.	<ul style="list-style-type: none"> • 1.5 Amps RMS continues • 3.5Amps RMS over any 2 second time period • Measure temperature rising by Energized current
Mechanical Requirements			
3.5.6	Mechanical Shock	No electrical discontinuity greater than 25 μ sec. shall occur	<ul style="list-style-type: none"> • 100g's,6ms duration • 1/2 sine pulse • 3 shocks in each direction • 3 mutually perpend, planes 18 shocks total • EIA 364-27
3.5.7	Vibration	No electrical discontinuity greater than 25 μ sec. shall occur	<ul style="list-style-type: none"> • Random Vibration • 3 mutually perpend. Planes • 15g peak • 10-2000Hz, 0.4g2/Hz • 20min per plane • EIA 364-28

Fig. 1 (CONT.)

Para.	Test Items	Requirements	Procedures
3.5.8	Insertion Force (Mating Force)	1Pos.: 1 N Max.	<ul style="list-style-type: none"> • Operation Speed: 100mm/min. • Measure the force required to mate connectors • EIA 364-13
3.5.9	Withdrawal Force (Un-mating Force)	1Pos.: 0.1 N Min.	<ul style="list-style-type: none"> • Operation Speed: 100mm/min. • Measure the force required to unmate connectors • EIA 364-13
3.5.10	Durability (Automatic Operation)	No contact crack allowed	<ul style="list-style-type: none"> • Operation Speed: 600cycles/hour Max. • Number of Cycles: 1000 cycles • As shown in Fig.3-1, 3-2 • EIA 364-9
3.5.11	Manual Durability	No contact crack allowed	<ul style="list-style-type: none"> • Number of Cycles: 1000 cycles • As shown in Fig.3-1, 3-2 • EIA 364-9
Environmental Requirements			
3.5.12	Thermal Shock	No physical damage allowed	<ul style="list-style-type: none"> • Mated connector, • -55°C/30min. 105°C/30min. Make this a cycle, repeat 5 cycles. • 5min(max.)transition to 105°C, • 5min(max.)transition to -55°C • EIA 364-32
3.5.13	Cyclic Humidity	No physical damage allowed	<ul style="list-style-type: none"> • Mated connector, • 25°C±3°C at 80%±3% RH and 65°C±3°C at 50%±3% RH. 24cycles • Ramp times should be 0.5 hour and dwell times should be 1.0hour. Dwell times start when the temperature and humidity have stabilized within the specified levels. • EIA 364—31
3.5.14	Temperature Life (Heat Aging)	No physical damage allowed	<ul style="list-style-type: none"> • Mated connector • 85°C for 120 hours • EIA 364-32
3.5.15	Salt Spray	No corrosion that damages function of connector allowed	<ul style="list-style-type: none"> • Mated connectors with 5% , 35°C concentration for 96hours • EIA 364-26
3.5.16	Resistance to Reflow Heat	No physical damage allowed	<ul style="list-style-type: none"> • Temperature profile; IPC/JEDEC J-STD-020D or latest revision level

Fig. 1 (End)

3.5 Product Qualification Test Sequence

Test Examination	Test Group						
	1	2	3	4	5	6	7
	Test Flow (a)						
Examination of Product	1,9	1,14	1,10	1,8	1,6	1,10	1,4
Resistance to Reflow heat	2	2	2		2	2	2
Low Level Contact resistance(LLCR)	3,6	5,9, 11,13	5,7		3,5	5,7	
Dielectric Withstanding Voltage(DWV)				2,6			
Insulation Resistance(I.R)				3,7			
Temperature Rising							3
Mechanical Shock	4						
Vibration	5						
Insertion(Mating) Force	7	3,7	3,8			3,8	
Withdrawal (Un-mating) Force	8	4,8	4,9			4,9	
Durability (Automatic Operation)		6					
Manual Durability			6				
Thermal Shock		10		4			
Cyclic Humidity		12		5			
Temperature Life (Heat Aging)						6	
Salt Spray					4		

Appendix 1

(a) Numbers indicate sequence in which the tests are performed.

The applicable product descriptions and part numbers are as shown in Appendix.2.

Product Part No.	Description
1554829-3	FLOATING BATTERY INTERCONNECTION SYSTEMS RECEPTACLE ASSEMBLY
2134167-1	FBIS-II PLUG ASSEMBLY 4 POS H TYPE

Appendix 2

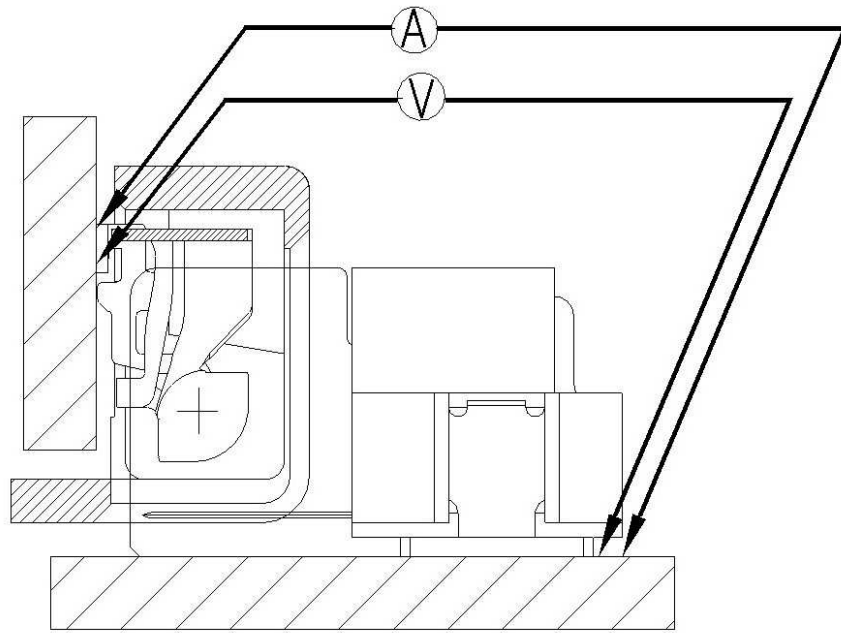

Fig.2 Termination Resistance Measuring Points

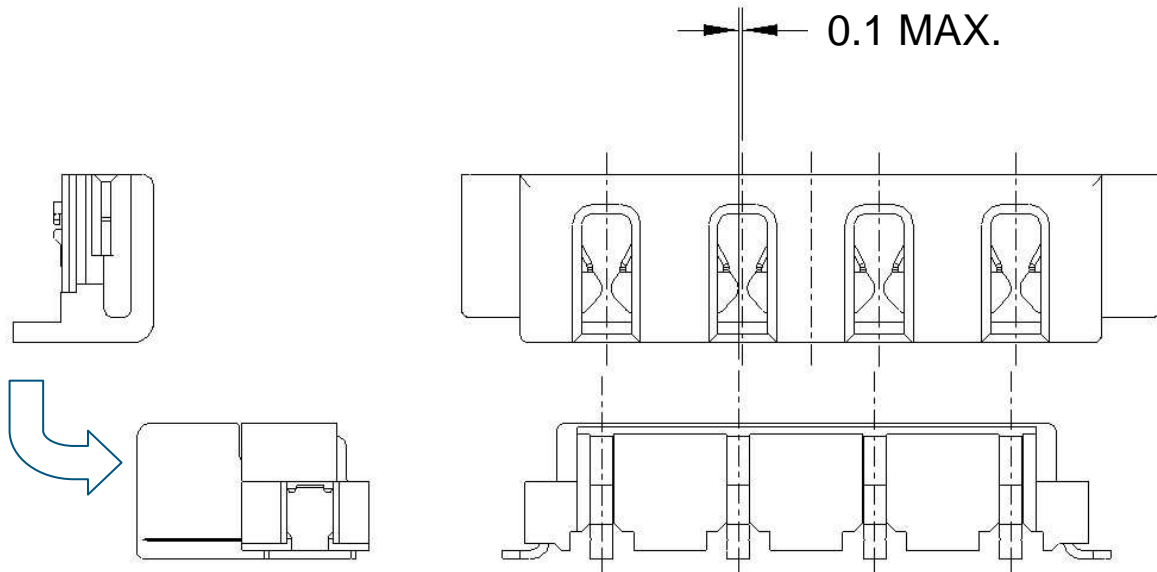

Fig.3-1 Displacement allowance for durability test

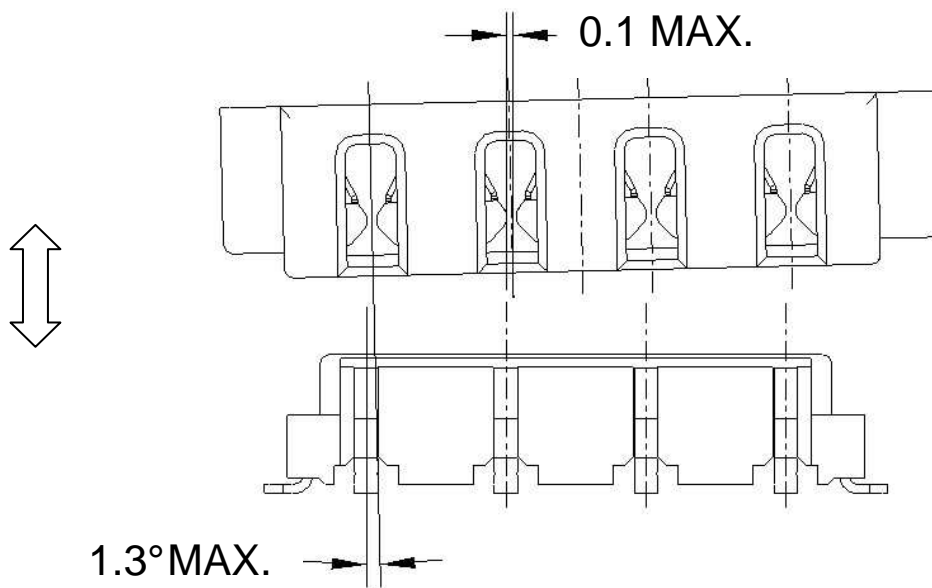

Fig.3-2 Tilt allowance for durability test

Компания «Life Electronics» занимается поставками электронных компонентов импортного и отечественного производства от производителей и со складов крупных дистрибьюторов Европы, Америки и Азии.

С конца 2013 года компания активно расширяет линейку поставок компонентов по направлению коаксиальный кабель, кварцевые генераторы и конденсаторы (керамические, пленочные, электролитические), за счёт заключения дистрибьюторских договоров

Мы предлагаем:

- Конкурентоспособные цены и скидки постоянным клиентам.
- Специальные условия для постоянных клиентов.
- Подбор аналогов.
- Поставку компонентов в любых объемах, удовлетворяющих вашим потребностям.
- Приемлемые сроки поставки, возможна ускоренная поставка.
- Доставку товара в любую точку России и стран СНГ.
- Комплексную поставку.
- Работу по проектам и поставку образцов.
- Формирование склада под заказчика.
- Сертификаты соответствия на поставляемую продукцию (по желанию клиента).
- Тестирование поставляемой продукции.
- Поставку компонентов, требующих военную и космическую приемку.
- Входной контроль качества.
- Наличие сертификата ISO.

В составе нашей компании организован Конструкторский отдел, призванный помогать разработчикам, и инженерам.

Конструкторский отдел помогает осуществить:

- Регистрацию проекта у производителя компонентов.
- Техническую поддержку проекта.
- Защиту от снятия компонента с производства.
- Оценку стоимости проекта по компонентам.
- Изготовление тестовой платы монтаж и пусконаладочные работы.



Тел: +7 (812) 336 43 04 (многоканальный)

Email: org@lifeelectronics.ru