



Features

- Cabinet can be pole or wall mounted for increased mounting flexibility
- All-weather NEMA 3R design steel cabinet is UL 50E tested for durability, ensuring long service life
- Conformal coating on all circuit boards protects against moisture
- Wide temperature AGM batteries ensure optimum performance and long service life
- Temperature-compensated three-stage charger improves reliability and performance
- Heavy-duty surge protection and noise filtering assures quality output
- Wide AC input voltage window lengthens battery life

U02 DC Series Outdoor UPS (AC/DC)

The Bourns® U02 DC Series Outdoor Uninterruptible Power Supply (UPS) is ideal for DC powered applications needing back-up power in extreme environmental conditions. This Outdoor DC UPS incorporates wide temperature AGM batteries and is housed in a weather-protected enclosure tested to UL 50E. It provides a wide input voltage range(100 - 140 V), heavy-duty surge protection and noise filtering.

The outdoor DC UPS provides a well-regulated DC output and uses a three-stage, temperature compensated battery charger for optimal battery life.

This heavy-duty outdoor UPS system is designed for outdoor telecommunications infrastructures, perimeter surveillance cameras (CCTV), wireless access points and industrial Remote Terminal Units (RTUs).

Characteristics

Specification	Model U02120-006-12-A	Model U02120-010-24-B	Model U02120-015-12-B	Model U02120-015-24-B
UPS Topology	AC to DC rectifier, battery charger and valve-regulated AGM batteries			
INPUT				
Nominal Voltage	120 V			
Operating Voltage	100 - 140 V			
Input Current	3.5 A	4.5 A	6.0 A	6.0 A
Operating Frequency	57 - 63 Hz			
AC Connections	Holes for 1/2 inch conduit connectors. Euro style wiring terminals for AWG 16			
Surge Voltage Withstand and Let-Through Performance	With ANSI/IEEE 6 kV, 1.2 x 50 μ s / 3 kA, 8 x 20 μ s; V out + to V out - <450 V, V out + or V out - to ground < 300 V			
OUTPUT				
Nominal Voltage	60 W 12 VDC	100 W 24 VDC	150 W 12 VDC	150 W 24 VDC
Operating Voltage	10 - 14 VDC	20 - 28 VDC	10 - 14 VDC	20 - 28 VDC
Output Current	5.22 A	4.26 A	13.04 A	5.22 A
Efficiency: Line/Back-up	84 / 96 %	84 / 98 %	84 / 95.5 %	84 / 98 %
Power On/Off Switch	On/off rocker style power switch			
Transfer Time to Back-up	0 ms			
DC Connections	Holes for 1/2 inch conduit connectors. Euro style wiring terminals for AWG 16			
BATTERY				
Battery Type: AGM	12 VDC 12 Ah	12 VDC 7 Ah x 2		
Recharge Time to 90 %	2 hrs. 45 min.	4 hrs.	2 hrs. 45 min.	2 hrs. 30 min.
Battery Back-up Time	93 min.	57 min.	37 min.	37 min.
PHYSICAL				
Dimensions	318 mm (12.5 ") wide x 305 mm (12 ") high x 165 mm (6.5 ") deep			
Steel Cabinet	All weather NEMA 3R design, UL 50E rain tested, padlockable enclosure			
Weight (lbs. / kg. w/Batteries)	30 / 13.6	32 / 14.5		
Mounting Options	Wall or optional bracket for pole (mounting bands not included)			
Latch	Unit doors are attached with Phillips Head #2 Pan head screws			
SAFETY STANDARDS				
cETLus 	ANSI/UL 60950-1 CAN/CSA C22.2: No. 60950-1-07 Clause; ANSI/UL 1778 CAN/CSAC22.2: No. 107.3-05 Clause; ANSI/UL 50E CAN/CSA C22.2: No. 94-2-07 Clause)			
ENVIRONMENTAL				
Operating Temperature	+14 to +131 °F / -10 to +55 °C -40 to +131 °F / -40 to +55 °C with BH5 optional battery heater			
Maximum Operating Temperature	+149 °F / +65 °C			

Specifications are subject to change without notice.

The device characteristics and parameters in this data sheet can and do vary in different applications and actual device performance may vary over time. Users should verify actual device performance in their specific applications.

Applications

- Perimeter surveillance cameras (CCTV)
- Wireless access points
- Industrial Remote Terminal Units (RTUs)

U02 DC Series Outdoor UPS (AC/DC)

BOURNS®

How to Order

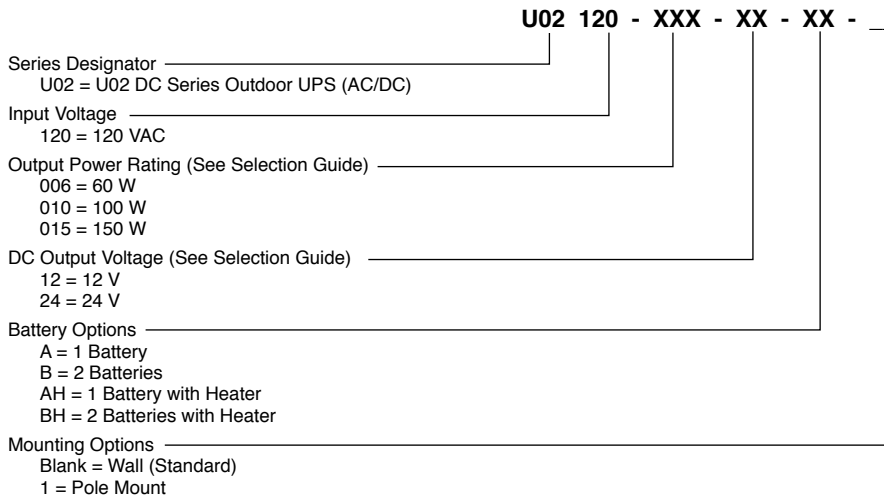

Standard Offering: Wall mount, Standard latch, 1 string, heated/unheated.

Product Images



Front View



Inside Front Panel



Side View

Selection Guides

How to Select Correct Output Power Rating and DC Output Voltage

DC Output Voltage	Output Power Rating		
	60 W	100 W	150 W
24 V	N/A	X	X
12 V	X	N/A	X

How to Select Battery Option w/Heater

DC Output Voltage	Output Power Rating		
	60 W	100 W	150 W
24 V	N/A	BH	BH
12 V	AH	N/A	BH

Mounting Options



Wall Mount



Rear View

Specifications are subject to change without notice.

The device characteristics and parameters in this data sheet can and do vary in different applications and actual device performance may vary over time.

Users should verify actual device performance in their specific applications.

U02 DC Series Outdoor UPS (AC/DC)

BOURNS®

DC Series Outdoor UPS (AC/DC) System Wiring Diagram

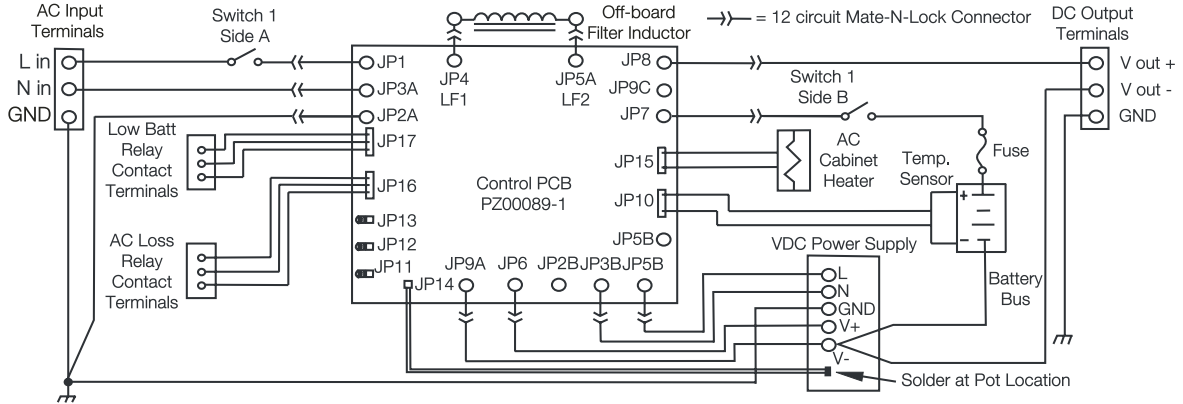

BOURNS®

Asia-Pacific: Tel: +886-2 2562-4117 • Fax: +886-2 2562-4116

EMEA: Tel: +36 88 520 390 • Fax: +36 88 520 211

The Americas: Tel: +1-951 781-5500 • Fax: +1-951 781-5700

www.bourns.com

REV. B 03/16

Specifications are subject to change without notice.

The device characteristics and parameters in this data sheet can and do vary in different applications and actual device performance may vary over time. Users should verify actual device performance in their specific applications.

Компания «Life Electronics» занимается поставками электронных компонентов импортного и отечественного производства от производителей и со складов крупных дистрибьюторов Европы, Америки и Азии.

С конца 2013 года компания активно расширяет линейку поставок компонентов по направлению коаксиальный кабель, кварцевые генераторы и конденсаторы (керамические, пленочные, электролитические), за счёт заключения дистрибьюторских договоров

Мы предлагаем:

- Конкурентоспособные цены и скидки постоянным клиентам.
- Специальные условия для постоянных клиентов.
- Подбор аналогов.
- Поставку компонентов в любых объемах, удовлетворяющих вашим потребностям.
- Приемлемые сроки поставки, возможна ускоренная поставка.
- Доставку товара в любую точку России и стран СНГ.
- Комплексную поставку.
- Работу по проектам и поставку образцов.
- Формирование склада под заказчика.
- Сертификаты соответствия на поставляемую продукцию (по желанию клиента).
- Тестирование поставляемой продукции.
- Поставку компонентов, требующих военную и космическую приемку.
- Входной контроль качества.
- Наличие сертификата ISO.

В составе нашей компании организован Конструкторский отдел, призванный помогать разработчикам, и инженерам.

Конструкторский отдел помогает осуществить:

- Регистрацию проекта у производителя компонентов.
- Техническую поддержку проекта.
- Защиту от снятия компонента с производства.
- Оценку стоимости проекта по компонентам.
- Изготовление тестовой платы монтаж и пусконаладочные работы.



Тел: +7 (812) 336 43 04 (многоканальный)

Email: org@lifeelectronics.ru