

I/O module - IB ST ZF 24 BDO 32/2 - 2750691

Please be informed that the data shown in this PDF Document is generated from our Online Catalog. Please find the complete data in the user's documentation. Our General Terms of Use for Downloads are valid (<http://phoenixcontact.com/download>)



INTERBUS-ST digital output module, 32 outputs, 24 V DC, 500 mA, 2-wire connection method, IP20 protection, consisting of: Terminal part with spring-cage connection and module electronics

The illustration shows version IB ST
24 BDO 32/2

Product Description

INTERBUS ST standard digital output modules

The digital INTERBUS output modules are designed for the connection of digital actuators, such as electromechanical valves, contactors or lamps. In addition to the standard IB ST 24 BDO modules, the range is rounded off by modules with extended functionality.

The scope of functions provided by the standard models covers the majority of applications. On top of this, several modules provide additional electronic functions, such as:

- Output channels in up to four electrically isolated groups
- Separate electronic short-circuit protection for each output channel
- Higher output current, which are needed in individual applications.

All the typical advantages of INTERBUS-ST handling, such as multi-wire connection methods and plug-in electronics are provided by both product lines.

Product Features

- 32 digital outputs
- Nominal current per output: 500 mA
- Connection of actuators in 2-wire technology
- Electrical isolation
- Diagnostic and status indicators



Key Commercial Data

Packing unit	1 pc
Weight per Piece (excluding packing)	706.3 g
Custom tariff number	85389091
Country of origin	Germany

Technical data

Note

I/O module - IB ST ZF 24 BDO 32/2 - 2750691

Technical data

Note

Utilization restriction	EMC: class A product, see manufacturer's declaration in the download area
-------------------------	---

Dimensions

Width	118 mm
Height	117 mm
Depth	116 mm

Ambient conditions

Ambient temperature (operation)	0 °C ... 55 °C
Ambient temperature (storage/transport)	-25 °C ... 70 °C
Permissible humidity (operation)	75 % (non-condensing)
Permissible humidity (storage/transport)	95 % (non-condensing)
Air pressure (operation)	86 kPa ... 108 kPa (1500 m above sea level)
Air pressure (storage/transport)	86 kPa ... 108 kPa (1500 m above sea level)
Degree of protection	IP20

Interfaces

Fieldbus system	Lokalbus
Designation	ST local bus
Connection method	ST local bus connector
Transmission speed	500 kBit/s

Digital outputs

Output name	Digital outputs
Connection method	Spring-cage connection
	2-wire
Number of outputs	32
Protective circuit	Short-circuit protection Electronic
Maximum output current per channel	500 mA
Maximum output current per module / terminal block	16 A
Maximum output current per group	16 A
Nominal load, inductive	12 VA
Nominal load, lamp	4 W
Nominal load, ohmic	12 W

Power supply for module electronics

Supply voltage	24 V DC
Supply voltage range	20 V DC ... 30 V DC (including ripple)
Ripple	3.6 V _{pp} within the allowable voltage range

I/O module - IB ST ZF 24 BDO 32/2 - 2750691

Technical data

Power supply for module electronics

Current consumption	100 mA
Communications power U _L	9 V DC
Current consumption	max. 100 mA

General

Mounting type	DIN rail
Net weight	691.3 g

Standards and Regulations

Test section	Supply voltage logic / I/O 500 V AC 50 Hz 1 min.
Connection in acc. with standard	CUL
Protection class	III, IEC 61140, EN 61140, VDE 0140-1

Classifications

eCl@ss

eCl@ss 4.0	27250302
eCl@ss 4.1	27250302
eCl@ss 5.0	27250302
eCl@ss 5.1	27242604
eCl@ss 6.0	27242604
eCl@ss 7.0	27242604
eCl@ss 8.0	27242604
eCl@ss 9.0	27242604

ETIM

ETIM 2.0	EC001430
ETIM 3.0	EC001599
ETIM 4.0	EC001599
ETIM 5.0	EC001599

UNSPSC

UNSPSC 6.01	43172015
UNSPSC 7.0901	43201404
UNSPSC 11	43172015
UNSPSC 12.01	43201404
UNSPSC 13.2	43201404

I/O module - IB ST ZF 24 BDO 32/2 - 2750691

Approvals

Approvals

Approvals

UL Recognized / cUL Recognized / EAC / cULus Recognized

Ex Approvals

Approvals submitted

Approval details

UL Recognized	
mm ² /AWG/kcmil	26-14
Nominal current I _N	0.005 A
Nominal voltage U _N	24 V

cUL Recognized	
mm ² /AWG/kcmil	26-14
Nominal current I _N	0.005 A
Nominal voltage U _N	24 V

EAC

cULus Recognized	
------------------	--

Accessories

Accessories

I/O module - IB ST ZF 24 BDO 32/2 - 2750691

Accessories

Bridge

Jumper - IB ST LBC - 2836492



Spare local bus cable, for INTERBUS-ST modules

Fuse

Fuse - IBS TR5 5AT - 2767383



Replacement fuse, for INTERBUS-ST modules

I/O component

Replacement electronics module - IB STME 24 BDO 32/2 - 2751713



Replacement module electronics for IB ST (ZF) 24 BDO 32/2

Replacement clamping part - IB STTB ZF 24 DO32/2 - 2750523



Replacement clamping part for IB ST ZF 24 (B)DO 32/2

Spare parts

I/O module - IB ST ZF 24 BDO 32/2 - 2750691

Accessories

Jumper - IB ST LBC - 2836492



Spare local bus cable, for INTERBUS-ST modules

Fuse - IBS TR5 5AT - 2767383



Replacement fuse, for INTERBUS-ST modules

Replacement electronics module - IB STME 24 BDO 32/2 - 2751713



Replacement module electronics for IB ST (ZF) 24 BDO 32/2

Drawings

Connection diagram

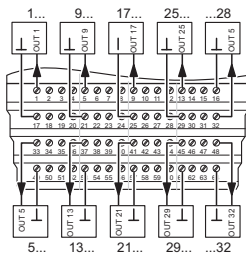

Dimensional drawing

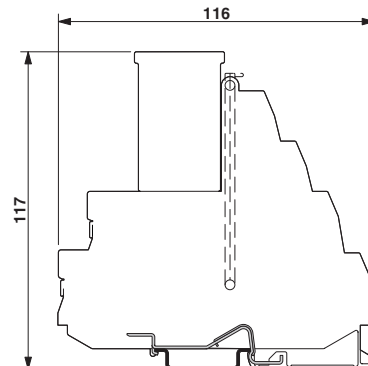

I/O module - IB ST ZF 24 BDO 32/2 - 2750691

Block diagram

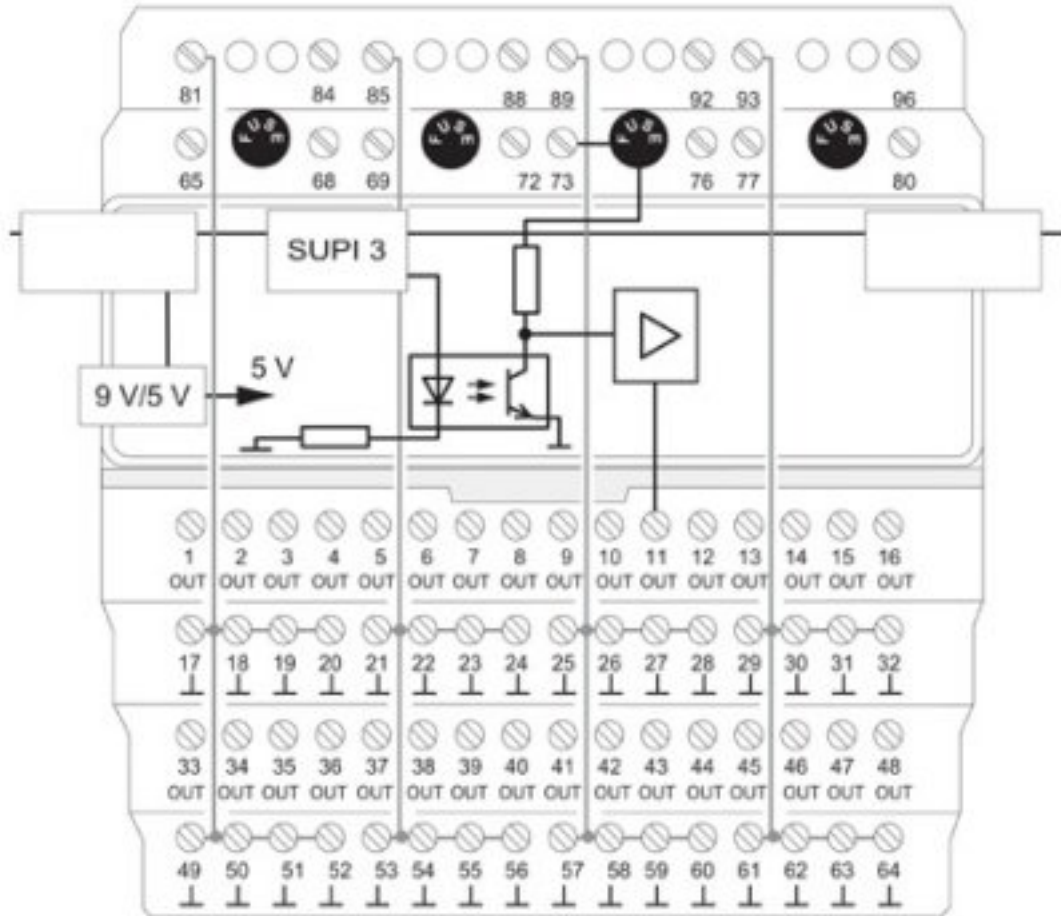

Компания «Life Electronics» занимается поставками электронных компонентов импортного и отечественного производства от производителей и со складов крупных дистрибьюторов Европы, Америки и Азии.

С конца 2013 года компания активно расширяет линейку поставок компонентов по направлению коаксиальный кабель, кварцевые генераторы и конденсаторы (керамические, пленочные, электролитические), за счёт заключения дистрибьюторских договоров

Мы предлагаем:

- Конкурентоспособные цены и скидки постоянным клиентам.
- Специальные условия для постоянных клиентов.
- Подбор аналогов.
- Поставку компонентов в любых объемах, удовлетворяющих вашим потребностям.
- Приемлемые сроки поставки, возможна ускоренная поставка.
- Доставку товара в любую точку России и стран СНГ.
- Комплексную поставку.
- Работу по проектам и поставку образцов.
- Формирование склада под заказчика.
- Сертификаты соответствия на поставляемую продукцию (по желанию клиента).
- Тестирование поставляемой продукции.
- Поставку компонентов, требующих военную и космическую приемку.
- Входной контроль качества.
- Наличие сертификата ISO.

В составе нашей компании организован Конструкторский отдел, призванный помогать разработчикам, и инженерам.

Конструкторский отдел помогает осуществить:

- Регистрацию проекта у производителя компонентов.
- Техническую поддержку проекта.
- Защиту от снятия компонента с производства.
- Оценку стоимости проекта по компонентам.
- Изготовление тестовой платы монтаж и пусконаладочные работы.



Тел: +7 (812) 336 43 04 (многоканальный)

Email: org@lifeelectronics.ru