

NEW



LED Power Supply Card Edge Type Connector

CONNECTOR

ES3 Series
(cULus Certified Product)

MB-0221-3

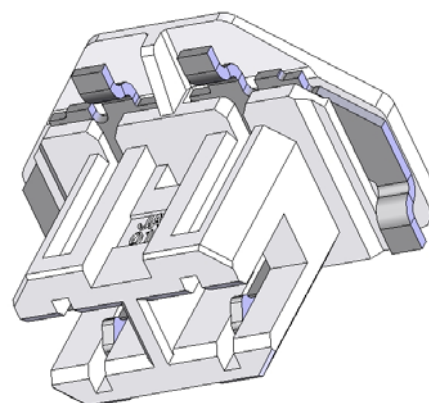
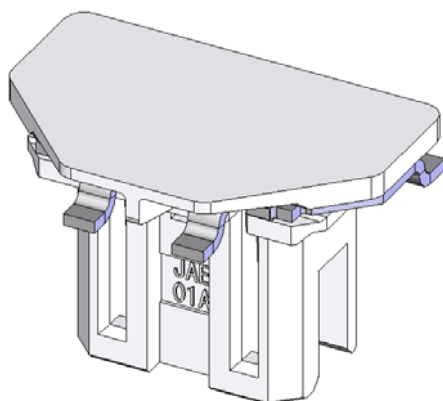
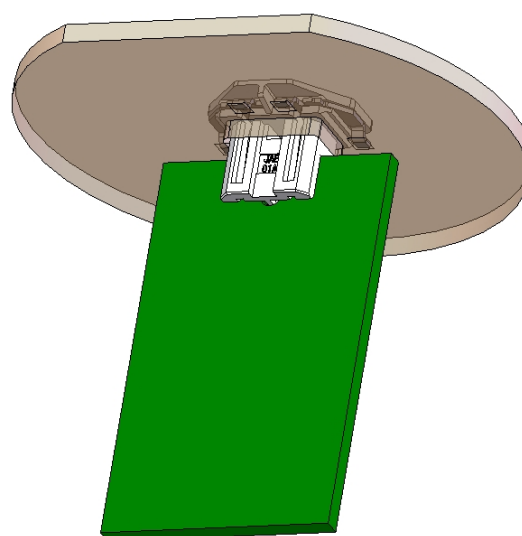
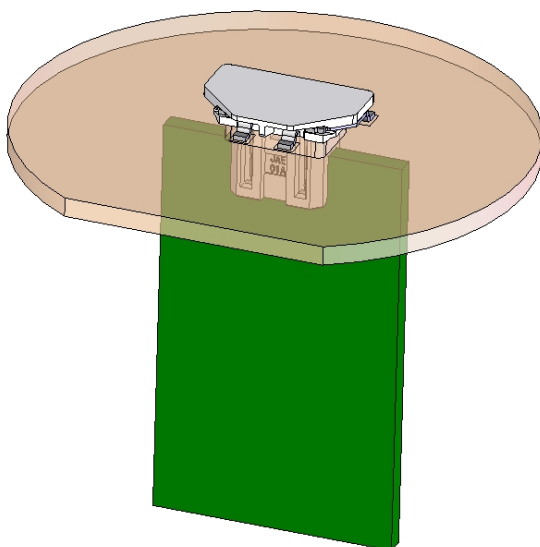
July 2012

RoHS Compliant

ES3B002WF1

The ES3 Series is a card edge connector for LED lighting power supply that enables direct connection of the converter board and the LED mounting board.

This connector is a 2-position card edge type ideal for LED bulb and LED lighting devices.

The ES3 Series connectors are available in embossed tape, compatible with SMT mounting.

The connector allows reflow solder mounting to the LED mounting board to occur at the same time that other parts like LED and SMT components are mounted.

Features

- Low-profile 1.6mm mounting height, designed with consideration for light shielding.
- Insulator is made of white LCP for heat and light resistance.
- Direct connection of converter board and LED mounting board allows for reduced assembly work time.
- Cable-less connection makes reduction in the number of parts possible.
- SMT type, can be mounted at the same time as other components to the LED mounting board.
- cULus Certification: File No. E67741 

General Specifications

- No. of Contacts: 2 pos.
- Contact Resistance: 60m Ω max. (initial)
- Dielectric Withstanding Voltage: AC 500Vr.m.s (per minute)
- Durability: 20 mating cycles
- Board Insertion Force: 30N max.
- Rated Current: AC, DC 1A
- Rated Voltage: AC, DC 200V
- Insulation Resistance: 10M Ω min. (after test)
- Operating Temperature: -40 to+105 Deg. C

Materials and Finishes

Component	Material / Finish
Insulator	White LCP
Contact-R	Copper alloy / Sn plating
Contact-L	Copper alloy / Sn plating

Ordering Information

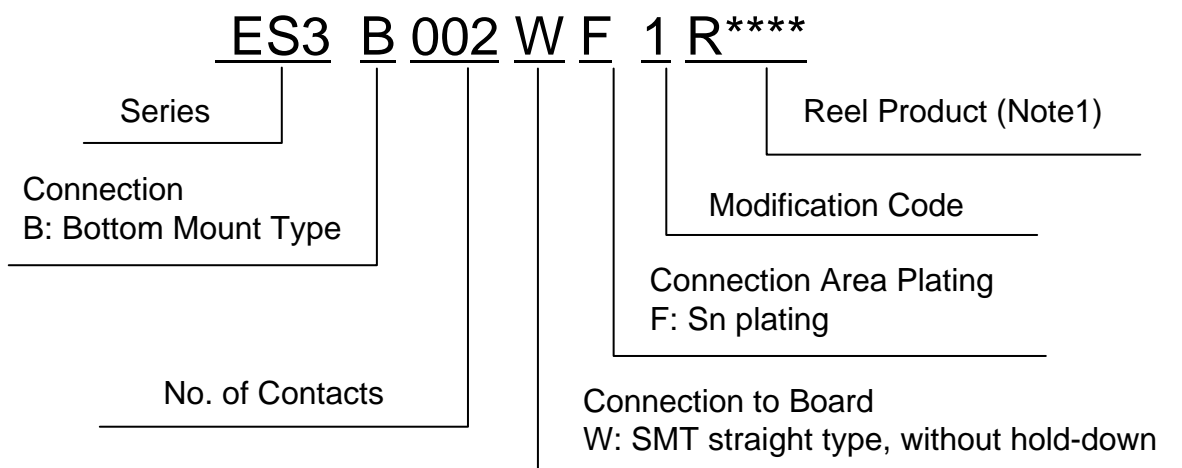

Note1) An embossed tape reel contains 1,000 pieces.

Drawing

Part Number	ES3B002WF1
SJ Drawing	SJ110395

Unit: mm

LISTED BY UL/cUL

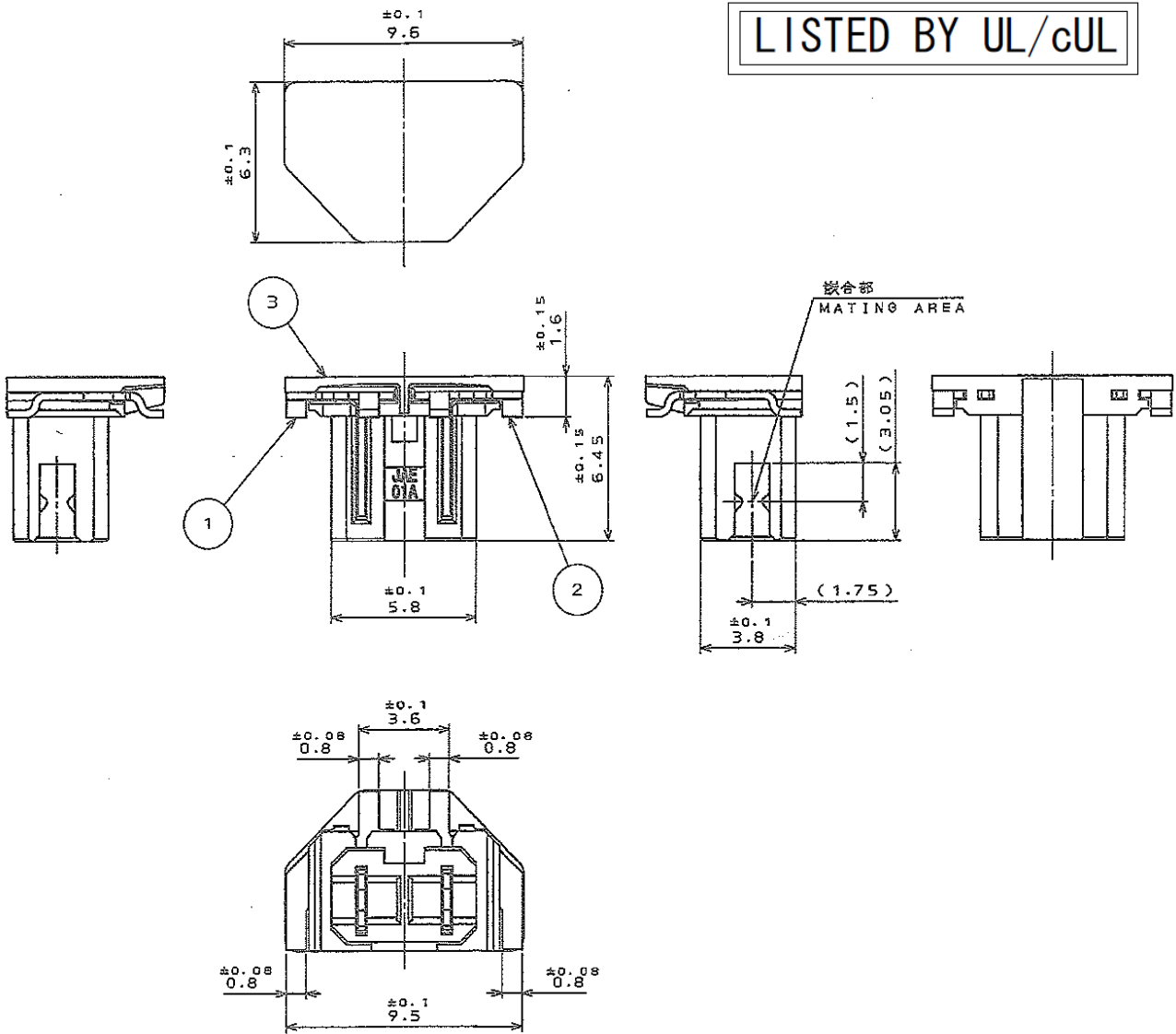

3	INSULATOR インシュレータ	1	LOP		COLOR: WHITE
2	CONTACT-R コンタクト-R	1	COPPER ALLOY 銅合金	LEAD-FREE TIN PLATING	
1	CONTACT-L コンタクト-L	1	COPPER ALLOY 銅合金	LEAD-FREE TIN PLATING	
符号 NO.	名称 DESCRIPTION	個数 QTY.	材料 MATERIAL	仕上 FINISH	備考 REMARKS

Unit: mm

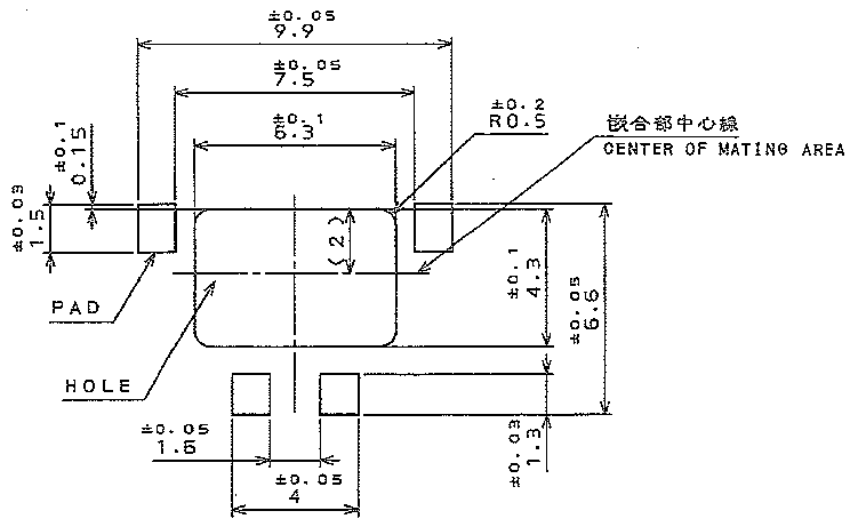

参考適合基板寸法 (SMT側)
APPLICABLE P.C.B. DIMENSION(SMT) (REF.)

Applicable Dimensions of Board
(SMT side, for reference)

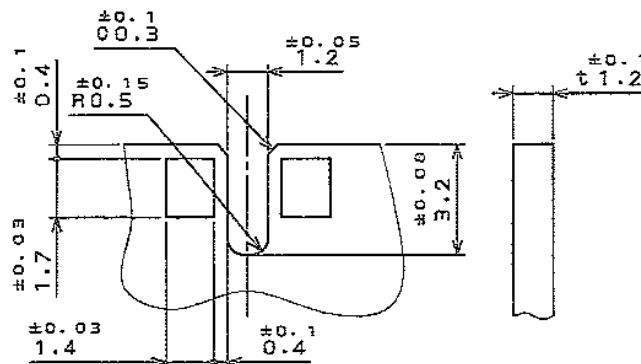

参考適合基板寸法 (カード側)
 (錫または錫合金めっき)
APPLICABLE P.C.B. DIMENSION(CARD) (REF.)
 (TIN / TIN ALLOY -PLATED)

Applicable Dimensions of Board
(Card side, for reference)

Part Number	ES3B002WF1R1000
SJ Drawing	SJ110396

Unit: mm

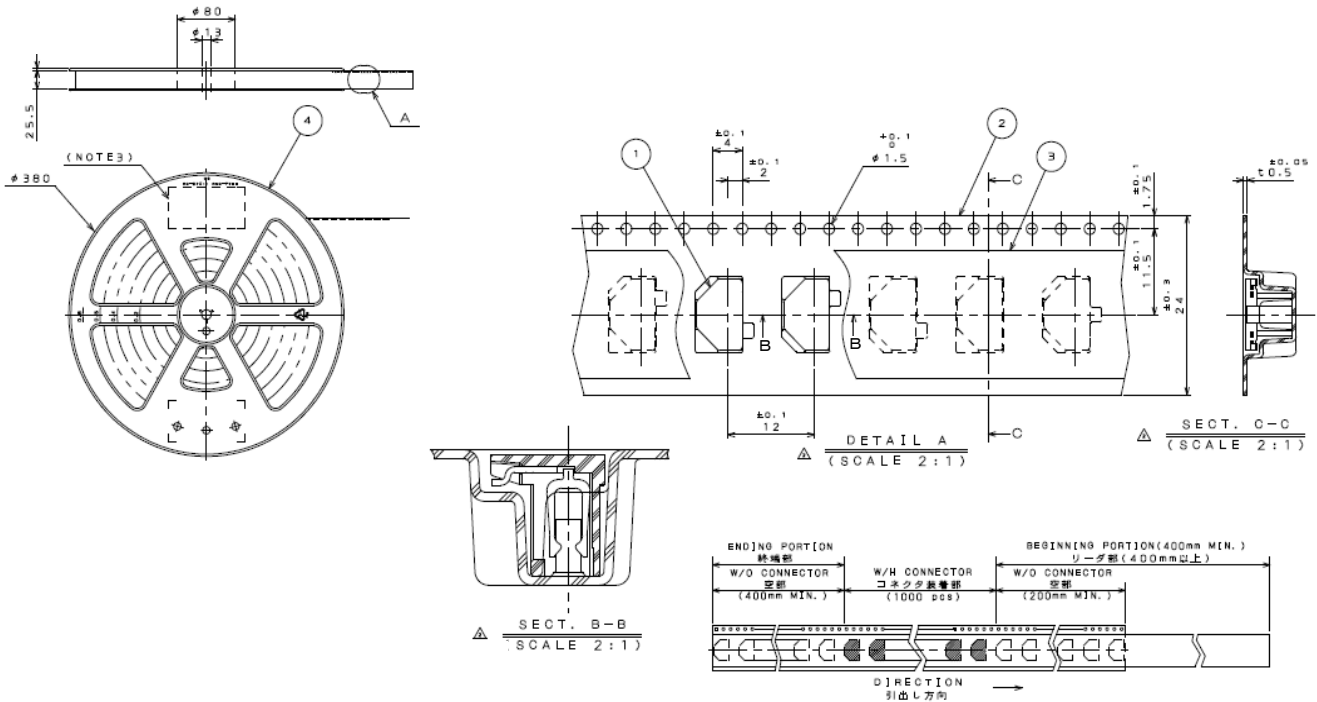

4	REEL	1	POLYSTYRENE	_____	
3	COVER TAPE	1	POLYESTER	_____	
2	CARRIER TAPE	1	POLYSTYRENE	_____	
1	CONNECTOR	1000	_____	_____	ES3B002WF1 SJ110395(連2)

Notice: Products shown in this brochure are made for the applications listed below. However, if the above-mentioned products are to be used in aerospace devices, marine cable-connection devices, atomic power control systems, medical equipment for life-support systems, or any other specific application requiring extremely high reliability, please contact JAE for further information.
Recommended applications: Computers, Office machines, Measuring devices, Telecommunication devices (Terminals, Mobile devices), AV devices, Household applications, FA devices, etc.

Japan Aviation Electronics Industry, Limited

Product Marketing Division
Aobadai Building, 3-1-19, Aobadai, Meguro-ku, Tokyo 153-8539
Phone: +81-3-3780-2787 FAX: +81-3-3780-2946

* The specifications in this brochure are subject to change without notice. Please contact JAE for information.

Mouser Electronics

Authorized Distributor

Click to View Pricing, Inventory, Delivery & Lifecycle Information:

[JAE Electronics:](#)

[ES3B002WF1R1000](#)

Компания «Life Electronics» занимается поставками электронных компонентов импортного и отечественного производства от производителей и со складов крупных дистрибьюторов Европы, Америки и Азии.

С конца 2013 года компания активно расширяет линейку поставок компонентов по направлению коаксиальный кабель, кварцевые генераторы и конденсаторы (керамические, пленочные, электролитические), за счёт заключения дистрибьюторских договоров

Мы предлагаем:

- Конкурентоспособные цены и скидки постоянным клиентам.
- Специальные условия для постоянных клиентов.
- Подбор аналогов.
- Поставку компонентов в любых объемах, удовлетворяющих вашим потребностям.
- Приемлемые сроки поставки, возможна ускоренная поставка.
- Доставку товара в любую точку России и стран СНГ.
- Комплексную поставку.
- Работу по проектам и поставку образцов.
- Формирование склада под заказчика.
- Сертификаты соответствия на поставляемую продукцию (по желанию клиента).
- Тестирование поставляемой продукции.
- Поставку компонентов, требующих военную и космическую приемку.
- Входной контроль качества.
- Наличие сертификата ISO.

В составе нашей компании организован Конструкторский отдел, призванный помогать разработчикам, и инженерам.

Конструкторский отдел помогает осуществить:

- Регистрацию проекта у производителя компонентов.
- Техническую поддержку проекта.
- Защиту от снятия компонента с производства.
- Оценку стоимости проекта по компонентам.
- Изготовление тестовой платы монтаж и пусконаладочные работы.



Тел: +7 (812) 336 43 04 (многоканальный)

Email: org@lifeelectronics.ru