

# HITFET

Smart Low Side Power Switch

# BTS3800SL

Small Protected Automotive Relay Driver  
Single Channel, 800m $\Omega$

## Datasheet

Rev. 1.1, 2011-04-30

Automotive

<b>1</b>	<b>Overview</b> .....	<b>3</b>
<b>2</b>	<b>Block Diagram</b> .....	<b>5</b>
2.1	Terms .....	5
<b>3</b>	<b>Pin Configuration</b> .....	<b>6</b>
3.1	Pin Assignment BTS3800SL .....	6
3.2	Pin Definitions and Functions .....	6
<b>4</b>	<b>General Product Characteristics</b> .....	<b>7</b>
4.1	Absolute Maximum Ratings .....	7
4.2	Functional Range .....	8
4.3	Thermal Resistance .....	8
<b>5</b>	<b>Input Stage</b> .....	<b>9</b>
5.1	Input Circuit .....	9
5.2	Input Characteristics .....	9
<b>6</b>	<b>Power stage</b> .....	<b>10</b>
6.1	Output On-state Resistance .....	10
6.2	Output Timing .....	11
6.3	Power Characteristics .....	11
<b>7</b>	<b>Protection Functions</b> .....	<b>13</b>
7.1	Over Load Protection .....	13
7.2	Over Temperature Protection .....	13
7.3	Reverse Polarity Protection .....	13
7.4	Protection Characteristics .....	14
<b>8</b>	<b>Package Outlines BTS3800SL</b> .....	<b>16</b>
<b>9</b>	<b>Revision History</b> .....	<b>17</b>



## 1 Overview

### Features

- Short circuit and over load protection
- Thermal shutdown with latch behavior
- ESD protection
- Over voltage protection
- Logic level input suitable for 5V and 3.3V
- Small footprint automotive power package
- Green Product (RoHS compliant)
- AEC Qualified

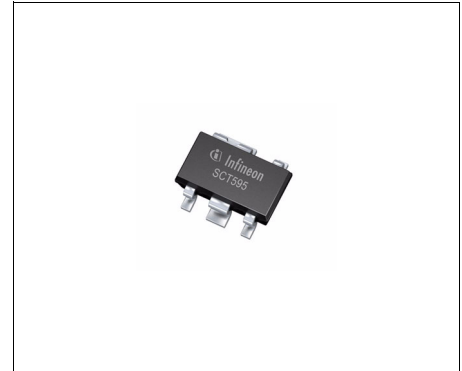

**PG-SCT595**

### Description

The BTS3800SL is a single channel Low Side power switch with embedded protective functions in PG-SCT595 package. The device is monolithically integrated with a N channel power MOSFET and additional protection functions.

The BTS3800SL is especially designed as a protected relay driver in automotive and industrial applications.

**Table 1 Product Summary**

Drain voltage <sup>1)</sup>	$V_{DS}$	41 V
Maximum Input Voltage	$V_{IN}$	5.5 V
Maximum On resistance at 150°C and 5V input voltage	$R_{DS(ON)}$	1.6 $\Omega$
Typical On-State resistance at 25°C and 5V input voltage	$R_{DS(ON)}$	0.8 $\Omega$
Nominal load current	$I_{D(nom)}$	350 mA
Minimum Current threshold level	$I_{D(OVL)}$	0.75 A
Single Clamping Energy	$E_{AS}$	65 mJ

1) Active clamped

Type	Package	Marking
BTS3800SL	PG-SCT595	38

**Protective Functions**

- Electrostatic discharge protection (ESD)
- Active clamping over voltage protection
- Thermal shutdown with latching behavior
- Short circuit protection
- Current threshold switch off

**Applications**

- Designed for driving relays in automotive and industrial applications
- Protected power switch for small loads
- Protected line driver
- Protected supply switch
- Replacement of discrete circuits

**Detailed Description**

The device is able to switch all kind of resistive, inductive and capacitive loads, limited by  $E_{AS}$  and maximum current capabilities.

The BTS3800SL offers ESD protection on the IN Pin referring to the Source Pin (Ground).

The overtemperature protection prevents the device from overheating due to overload and/or bad cooling conditions. The temperature information is given by a temperature sensor which is placed monolithically in the power stage.

The BTS3800SL has a thermal latch function. The device will turn off and stay off, even after the measured temperature has dropped below the thermal hysteresis. After cooling down the device can be switched on again by toggling the IN pin.

The over voltage protection is active during load dump or inductive turn off conditions.

In this conditions the power stage is limiting the Drain to Source voltage at  $V_{DS(AZ)}$  and dissipating energy.

## 2 Block Diagram

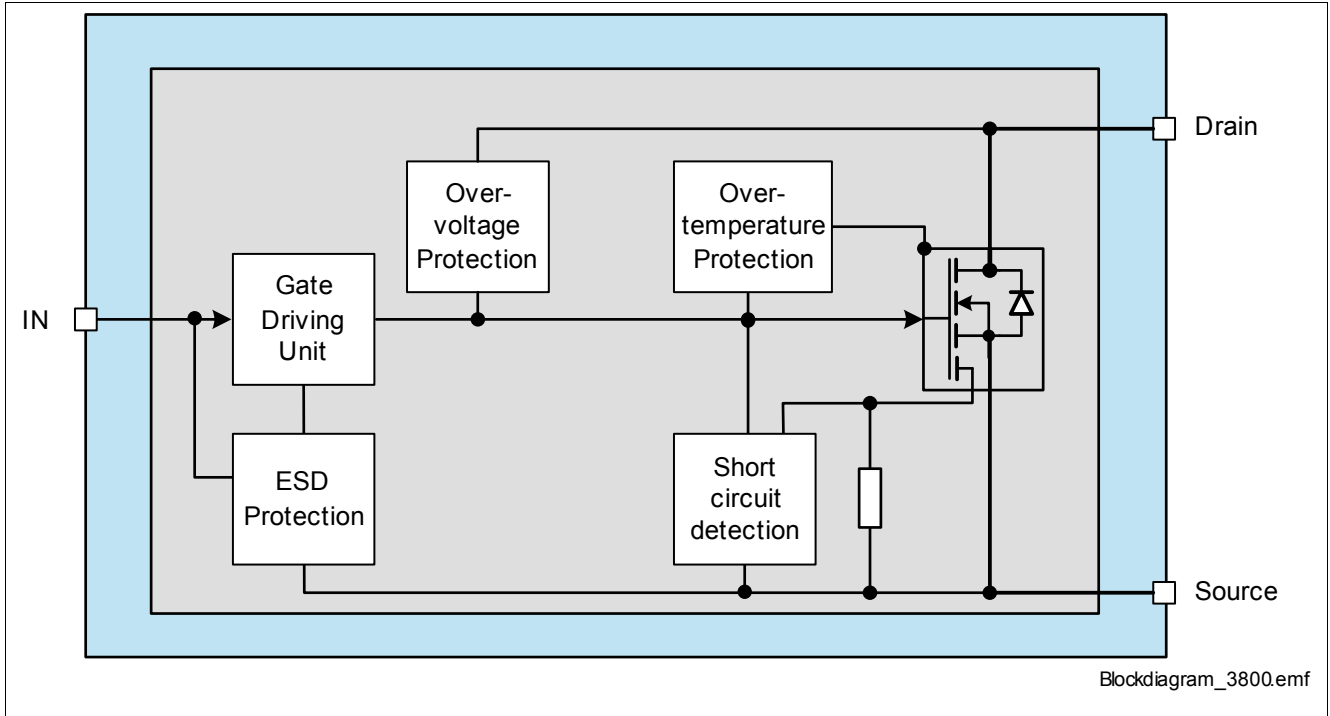

Figure 1 Block Diagram of BTS3800SL

### 2.1 Terms

Figure 2 shows all external terms used in this data sheet.

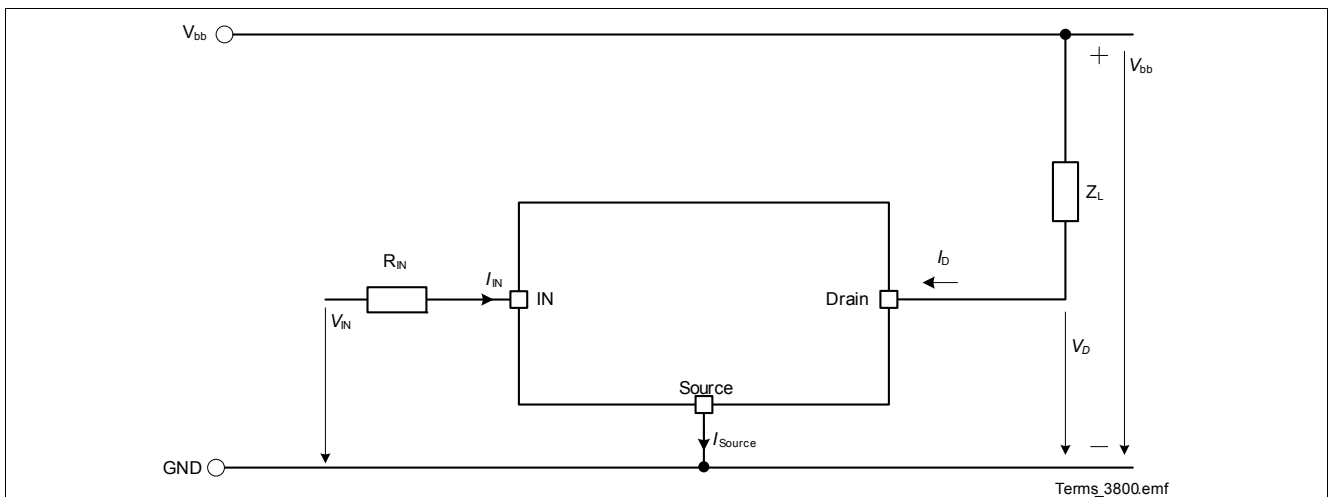

Figure 2 Naming of electrical parameters

### 3 Pin Configuration

#### 3.1 Pin Assignment BTS3800SL

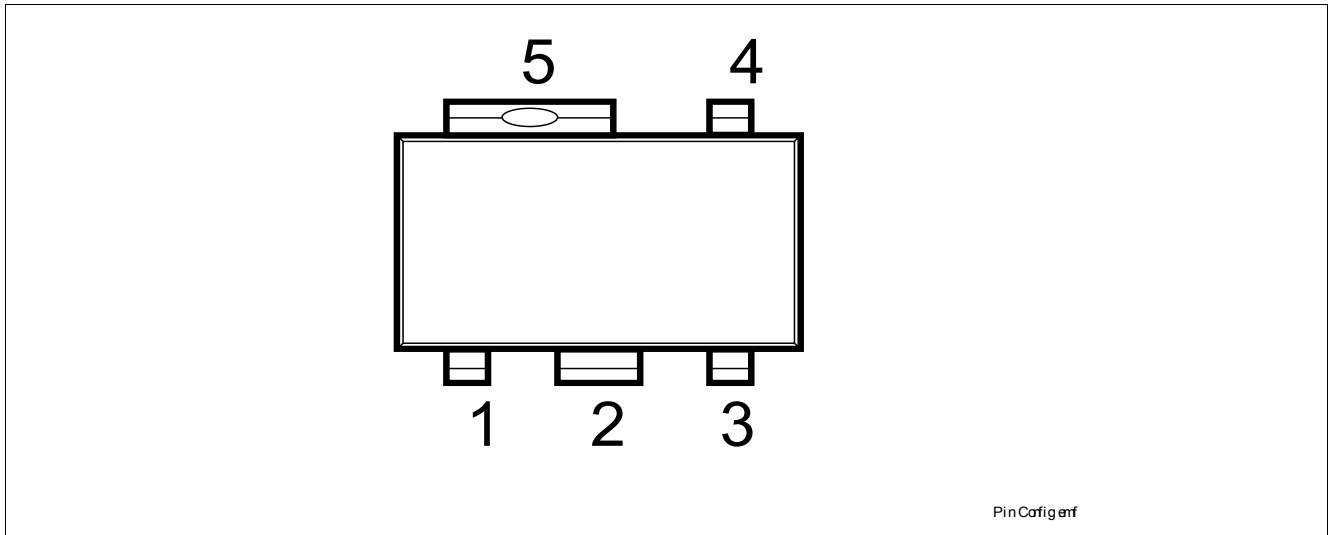

Figure 3 Pin Configuration PG-SCT595

#### 3.2 Pin Definitions and Functions

Pin	Symbol	Function
1	Drain	<b>Drain pin</b> ; Load connection for power DMOS
2,5	n.c.	<b>not connected</b> ; Should be connected to ground for cooling
3	IN	<b>Input pin</b> ; Digital input
4	Source	<b>Source pin</b> ; Ground, Source of power DMOS

## 4 General Product Characteristics

### 4.1 Absolute Maximum Ratings

#### Absolute Maximum Ratings<sup>1)</sup>

$T_j = -40\text{ °C}$  to  $+150\text{ °C}$ ; all voltages with respect to ground, positive current flowing into pin  
(unless otherwise specified)

Pos.	Parameter	Symbol	Limit Values		Unit	Test Conditions	
			Min.	Max.			
<b>Voltages</b>							
4.1.1	Drain voltage	$V_{DS}$	–	41	V	<sup>2)</sup>	
4.1.2	Drain voltage for short circuit protection	$V_{DS(SC)}$	–	36	V		
4.1.3	Input Voltage	$V_{IN}$	-0.3	5.5	V	–	
4.1.4	Input Current	$I_{IN}$	self limited			$-0.3\text{ V} < V_{IN} < 5.5\text{ V}$	
			-4	4	mA	$5.5\text{ V} < V_{IN} < 8.0\text{ V}$	
4.1.5	Maximum Drain Current	$I_D$	–	0.75	A	<sup>3)</sup>	
<b>Energies</b>							
4.1.6	Unclamped single pulse inductive energy	$E_{AS}$	–	65	mJ	$I_D = 350\text{mA}$ ; $T_{J(start)} = 150\text{ °C}$	
4.1.7	Unclamped repetitive pulse inductive energy $1 \times 10^4$ cycles	$E_{AR}$	–	14	mJ	$I_D = 350\text{mA}$ ; $V_{bb} = 18\text{ V}$ ; $T_{J(start)} = 85\text{ °C}$	
4.1.8	Unclamped repetitive pulse inductive energy $1 \times 10^6$ cycles		–	12	mJ	$I_D = 350\text{mA}$ ; $V_{bb} = 18\text{V}$ ; $T_{J(start)} = 85\text{ °C}$	
<b>Temperatures</b>							
4.1.9	Operating temperature	$T_J$	-40	+150	°C	–	
4.1.10	Storage temperature	$T_{STG}$	-55	+150	°C	–	
<b>ESD Susceptibility</b>							
4.1.11	ESD Resistivity	$V_{ESD}$			kV	HBM <sup>4)</sup>	
			All pins	-4			4
			Drain vs. Source	-8			8

1) Not subject to production test, specified by design.

2) Active clamped.

3) Current protection threshold see **“Over Load Protection” on Page 13** for details.

4) ESD susceptibility, HBM according to EIA/JESD 22-A114.

*Note: Stresses above the ones listed here may cause permanent damage to the device.*

*Exposure to absolute maximum rating conditions for extended periods may affect device reliability.*

*Note: Integrated protection functions are designed to prevent IC destruction under fault conditions described in the data sheet. Fault conditions are considered as “outside” normal operating range.*

*Protection functions are not designed for continuous repetitive operation.*

## 4.2 Functional Range

Pos.	Parameter	Symbol	Limit Values		Unit	Conditions
			Min.	Max.		
4.2.1	Input pin voltage (device ON)	$V_{IN}$	2.7	5.5	V	–
4.2.1	Drain voltage	$V_D$	–	41	V	active clamped
4.2.2	Input pin current consumption	$I_{IN(ON)}$	–	0.5	mA	

Note: Within the functional range the IC operates as described in the circuit description. The electrical characteristics are specified within the conditions given in the related electrical characteristics table.

## 4.3 Thermal Resistance

Note: This thermal data was generated in accordance with JEDEC JESD51 standards.  
 For more information, go to [www.jedec.org](http://www.jedec.org).

Pos.	Parameter	Symbol	Limit Values			Unit	Conditions
			Min.	Typ.	Max.		
4.3.3	Junction to Pin 5	$R_{thJpin}$	–	–	27	K/W	1) 2)
4.3.4	Junction to Ambient (2s2p)	$R_{thJA}$	–	110	–	K/W	1) 3)

- 1) Not subject to production test, specified by design
- 2) Specified  $R_{thJpin}$  value is simulated at natural convection on a cold plate setup (all pins are fixed to ambient temperature).  $T_a = 25\text{ °C}$ . Device is loaded with 0.5 W power.
- 3) Specified  $R_{thJA}$  value is according to Jedec JESD51-2,-7 at natural convection on FR4 2s2p board; The product (Chip+Package) was simulated on a 76.2 x 114.3 x 1.5 mm board with 2 inner copper layers (2 x 70  $\mu\text{m}$  Cu, 2 x 35  $\mu\text{m}$  Cu).  $T_a = 25\text{ °C}$ , Device is loaded with 0.5 W power.



## 5 Input Stage

The following chapter describes the behavior and characteristic of the input pin.

### 5.1 Input Circuit

**Figure 4** shows the input circuit of the BTS3800SL. The Zener diode protects the input circuit against ESD pulses. The internal circuitry is powered via the input pin. During normal operation the input is connected to the gate of the power MOSFET. The current handling capability of the driving circuit does not influence the device behavior as long as the supply current  $I_{IN(nom)}$  is supplied.

During PWM operation the recharging of the gate increases the current consumption to the level  $I_{IN(PWM)}$ .

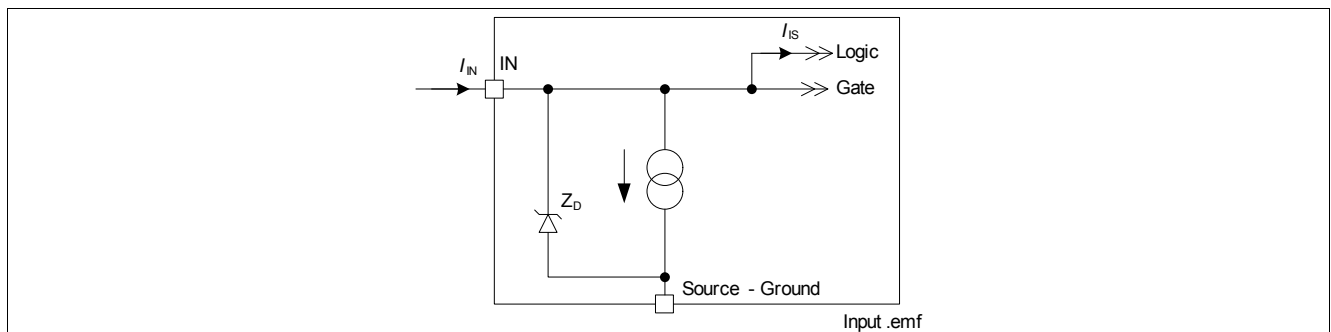

**Figure 4 Input Circuit**

The current sink to ground ensures that the channel switches off in case of an open input pin. The Zener diode protects the input circuit against ESD pulses.

### 5.2 Input Characteristics

*Note: Characteristics show the deviation of parameter at given input voltage and junction temperature.*

*Typical values show the typical parameters expected from manufacturing.*

*All voltages with respect to Source Pin unless otherwise stated.*

#### Electrical Characteristics: Input Stage

$T_j = -40\text{ °C to }+150\text{ °C}$ ,  $V_{bat} = 8.0\text{ V to }18\text{ V}$ ,

all voltages with respect to ground, positive current flowing into pin (unless otherwise specified)

Pos.	Parameter	Symbol	Limit Values			Unit	Test Conditions
			Min.	Typ.	Max.		
<b>Input</b>							
5.2.1	Supply current from Input Pin	$I_{IN(ON)}$	–	0.25	0.5	mA	$V_{DS} = 0\text{ V};$ $V_{IN} = 5.5\text{ V}$
5.2.2	Supply current during PWM	$I_{IN(PWM)}$	–	0.3	0.6	mA	<sup>1)</sup> $V_{IN} = 5.5\text{ V}$ with 20kHz PWM (50%DC)
5.2.3	Input ON threshold voltage	$V_{IN(th)}$	–	2.3	2.7	V	$V_{DS} = 13.5\text{ V};$ $I_D = 350\text{ mA}$

1) Not subject to production test

## 6 Power stage

### 6.1 Output On-state Resistance

The on-state resistance depends on the junction temperature  $T_J$  and on the applied input voltage.

The following Figures show the dependencies for the typical on-state resistance  $R_{DS(on)}$ .

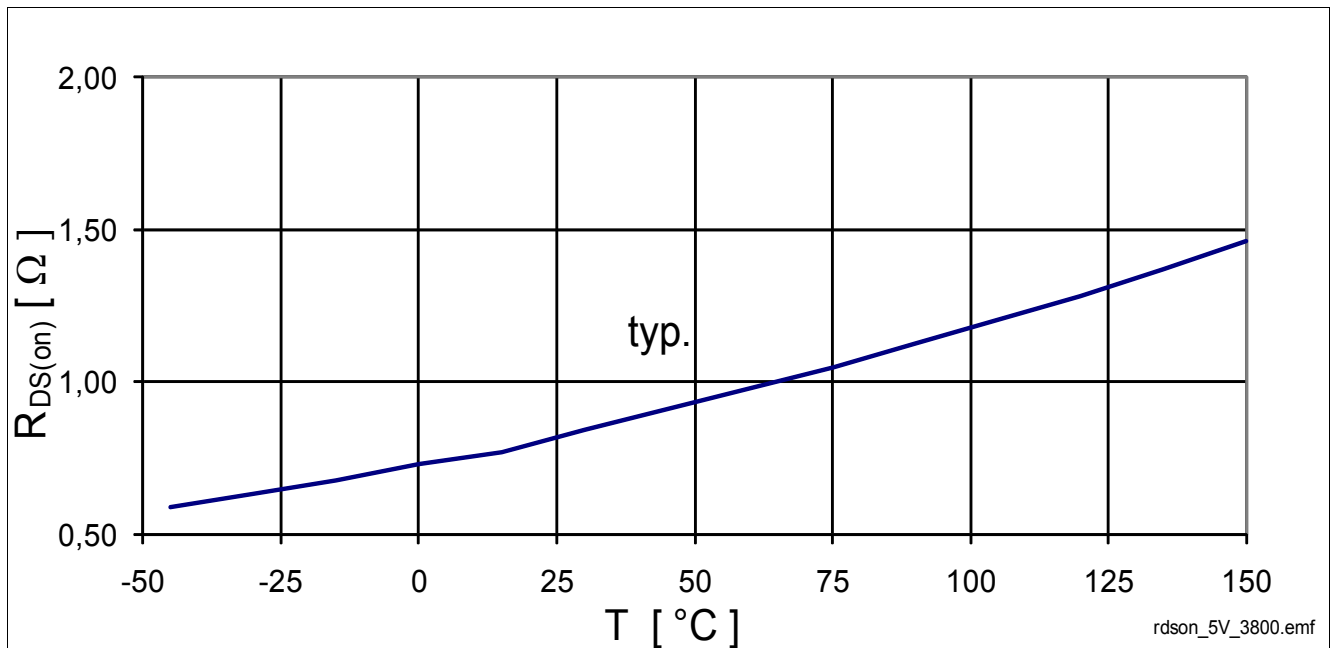

Figure 5 BTS3800 Typical On-State Resistance,  $R_{DS(on)} = f(T_J)$ ,  $V_{IN} = 5.5\text{V}$

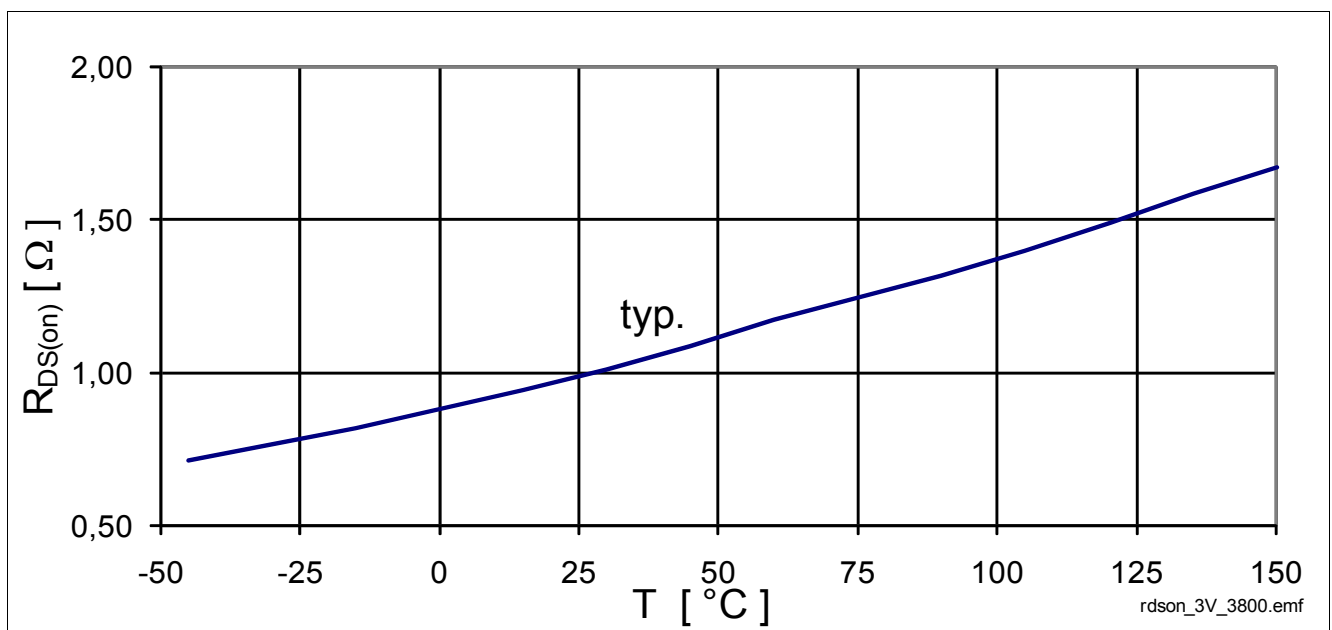

Figure 6 BTS3800 Typical On-State Resistance,  $R_{DS(on)} = f(T_J)$ ,  $V_{IN} = 3\text{V}$

## 6.2 Output Timing

A voltage signal at the input pin above the threshold voltage causes the power MOSFET to switch on.

Figure 7 shows the timing definition.

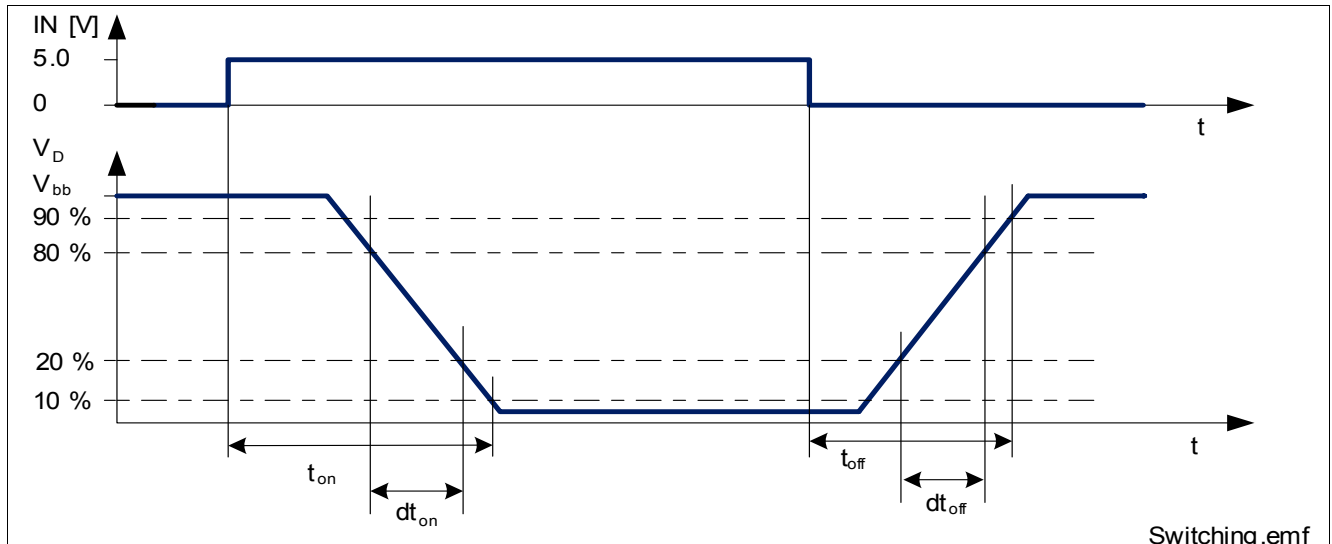

Figure 7 Definition of Power Output Timing for Resistive Load

## 6.3 Power Characteristics

Note: Characteristics show the deviation of parameter at given input voltage and junction temperature.

Typical values show the typical parameters expected from manufacturing.

All voltages with respect to Source Pin unless otherwise stated.

### Electrical Characteristics: Power Stage

$T_j = -40\text{ °C}$  to  $+150\text{ °C}$ ,  $V_{bat} = 8.0\text{ V}$  to  $18\text{ V}$ ,

all voltages with respect to ground, positive current flowing into pin (unless otherwise specified)

Pos.	Parameter	Symbol	Limit Values			Unit	Test Conditions
			Min.	Typ.	Max.		
<b>Power Stage</b>							
6.3.1	On-State Resistance	$R_{DS(on)}$	–	0.8	–	$\Omega$	<sup>1)</sup> $T_j = 25\text{ °C}$ ; $V_{IN} = 5.5\text{ V}$ $I_D = 350\text{ mA}$
			–	1.4	1.6	$\Omega$	$T_j = 150\text{ °C}$ ; $V_{IN} = 5.5\text{ V}$ $I_D = 350\text{ mA}$
			–	1.0	–	$\Omega$	<sup>1)</sup> $T_j = 25\text{ °C}$ ; $V_{IN} = 3\text{ V}$ $I_D = 350\text{ mA}$
			–	1.7	2.0	$\Omega$	<sup>1)</sup> $T_j = 150\text{ °C}$ ; $V_{IN} = 3\text{ V}$ $I_D = 350\text{ mA}$
6.3.2	Nominal load current	$I_{D(nom)}$	350	520	–	mA	<sup>2)</sup> $T_j < 150\text{ °C}$ ; $T_A = 105\text{ °C}$ ; $V_{IN} = 5\text{ V}$ ; $V_{DS} = 0.5\text{ V}$

**Electrical Characteristics: Power Stage (cont'd)**
 $T_j = -40\text{ °C to }+150\text{ °C}$ ,  $V_{bat} = 8.0\text{ V to }18\text{ V}$ ,

all voltages with respect to ground, positive current flowing into pin (unless otherwise specified)

Pos.	Parameter	Symbol	Limit Values			Unit	Test Conditions
			Min.	Typ.	Max.		
6.3.3	Zero input voltage drain leakage current	$I_{DSS}$	–	2.5	6	$\mu\text{A}$	$V_D = 36\text{ V}; V_{IN} = 0\text{ V};$
			–	–	0.2 0.5 2	$\mu\text{A}$	$V_D = 13.5\text{ V}; V_{IN} = 0\text{ V};$ $T_J = 25\text{ °C}^{1)}$ $T_J = 85\text{ °C}^{1)}$ $T_J = 150\text{ °C}$

**Switching**  $V_{bb} = 13.5\text{ V}$ ,  $R_L = 38\ \Omega$ ,  $V_{IN} = 5.0\text{ V}$ 

6.3.4	Turn-on time	$t_{on}$	–	3	5	$\mu\text{s}$	see <a href="#">Figure 7</a> for definition
6.3.5	Turn-off time	$t_{off}$	–	3	5	$\mu\text{s}$	see <a href="#">Figure 7</a> for definition
6.3.6	Slew rate on	$-dV_{ds}/dt_{on}$	–	6	12		$dV_D = 80\text{ to }20\% V_{bb}$ see <a href="#">Figure 7</a>
6.3.7	Slew rate off	$dV_{ds}/dt_{off}$	–	12	22		$dV_D = 20\text{ to }80\% V_{bb}$ see <a href="#">Figure 7</a>

**Inverse Diode**

6.3.8	Inverse Diode forward voltage	$V_{SD}$	–	-1.0	-1.5	V	$I_D = 350\text{ mA}$ $V_{IN} = 0\text{ V}$
-------	-------------------------------	----------	---	------	------	---	--

1) Not subject to production test, guaranteed by design.

 2) Not subject to production test, calculated by  $R_{thJA}$  and  $R_{DS(on)}$ .

## 7 Protection Functions

The device provides embedded protective functions. Integrated protection functions are designed to prevent IC destruction under fault conditions described in this datasheet. Fault conditions are considered as “outside” normal operating range. Protection functions are not designed for continuous repetitive operation.

### 7.1 Over Load Protection

The BTS3800SL is protected in case of over load or short circuit of the load. After time  $t_{\text{OFF(OVL)}}$ , the device switches off. It can be switched on by toggeling the IN pin. Please refer to [Figure 8](#) for details.

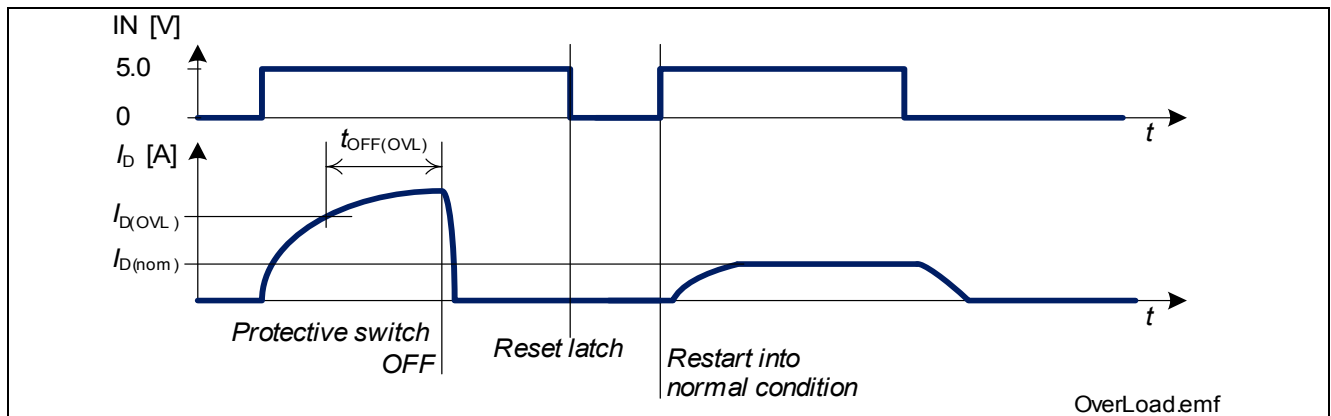

Figure 8 Shut down at over load

### 7.2 Over Temperature Protection

A temperature sensor causes a overheated BTS3800SL to switch off to prevent destruction. It can be switched on again by toggeling the IN pin.

### 7.3 Reverse Polarity Protection

In case of reverse polarity, the intrinsic body diode of the power transistor causes power dissipation. The reverse current through the intrinsic body diode of the power transistor has to be limited by the connected load.

The over temperature and over load protection is not active during reverse polarity.

## 7.4 Protection Characteristics

Note: Characteristics show the deviation of parameter at given supply voltage and junction temperature. Typical values show the typical parameters expected from manufacturing.

### Electrical Characteristics: Protection

$T_j = -40\text{ °C to }+150\text{ °C}$ ,  $V_{\text{bat}} = 8.0\text{ V to }18\text{V}$ ,

all voltages with respect to ground, positive current flowing into pin (unless otherwise specified)

Pos.	Parameter	Symbol	Limit Values			Unit	Conditions
			Min.	Typ.	Max.		
<b>Over Load Protection</b>							
7.4.1	Over load detection current	$I_{D(\text{OVL})}$	0.75	–	1.5	A	
7.4.2	Over load shut-down delay time	$t_{\text{OFF}(\text{OVL})}$	5	–	15	μs	$V_{\text{IN}} = 5\text{ V}$
<b>Over Temperature Protection</b>							
7.4.3	Thermal shut down temperature	$T_{j(\text{SC})}$	150	170	200	°C	<sup>1)</sup>
<b>Over Voltage Protection</b>							
7.4.4	Output clamping voltage	$V_{\text{DS}(\text{AZ})}$	41	–	50	V	$I_D = 10\text{ mA}$ $V_{\text{IN}} = 0\text{ V}$

1) Not subject to production test, specified by design.



## 8 Package Outlines BTS3800SL

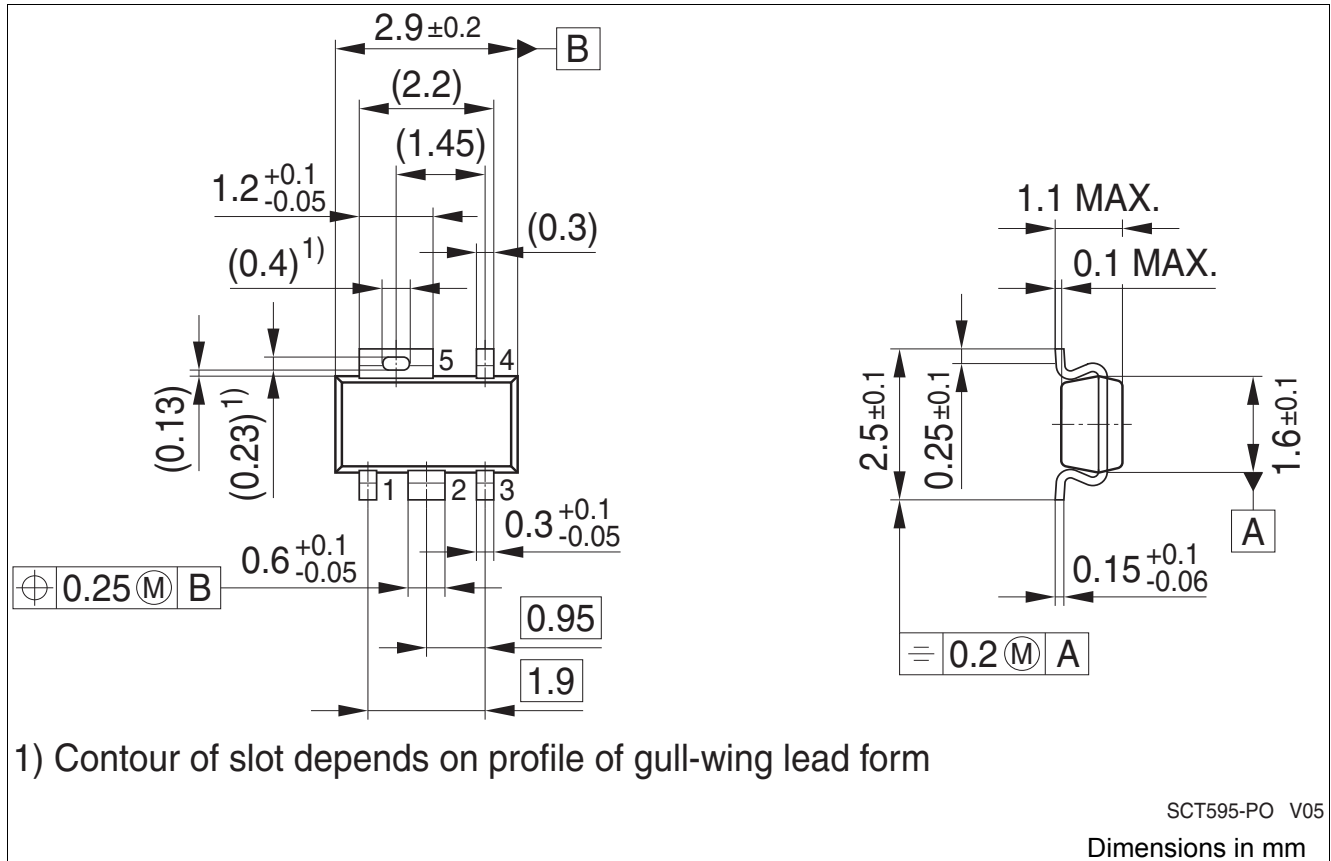

Figure 9 PG-SCT595 (Plastic Green Semiconductor Transistor Package)

### Green Product (RoHS compliant)

To meet the world-wide customer requirements for environmentally friendly products and to be compliant with government regulations the device is available as a green product. Green products are RoHS-Compliant (i.e. Pb-free finish on leads and suitable for Pb-free soldering according to IPC/JEDEC J-STD-020).

For further information on packages, please visit our website:  
<http://www.infineon.com/packages>.



## **9 Revision History**

<b>Version</b>	<b>Date</b>	<b>Changes</b>
Rev. 1.1	2011-04-30	initial released data sheet

**Edition 2011-04-30**

**Published by  
Infineon Technologies AG  
81726 Munich, Germany**

**© 2011 Infineon Technologies AG  
All Rights Reserved.**

### **Legal Disclaimer**

The information given in this document shall in no event be regarded as a guarantee of conditions or characteristics. With respect to any examples or hints given herein, any typical values stated herein and/or any information regarding the application of the device, Infineon Technologies hereby disclaims any and all warranties and liabilities of any kind, including without limitation, warranties of non-infringement of intellectual property rights of any third party.

### **Information**

For further information on technology, delivery terms and conditions and prices, please contact the nearest Infineon Technologies Office ([www.infineon.com](http://www.infineon.com)).

### **Warnings**

Due to technical requirements, components may contain dangerous substances. For information on the types in question, please contact the nearest Infineon Technologies Office.

Infineon Technologies components may be used in life-support devices or systems only with the express written approval of Infineon Technologies, if a failure of such components can reasonably be expected to cause the failure of that life-support device or system or to affect the safety or effectiveness of that device or system. Life support devices or systems are intended to be implanted in the human body or to support and/or maintain and sustain and/or protect human life. If they fail, it is reasonable to assume that the health of the user or other persons may be endangered.

Компания «Life Electronics» занимается поставками электронных компонентов импортного и отечественного производства от производителей и со складов крупных дистрибьюторов Европы, Америки и Азии.

С конца 2013 года компания активно расширяет линейку поставок компонентов по направлению коаксиальный кабель, кварцевые генераторы и конденсаторы (керамические, пленочные, электролитические), за счёт заключения дистрибьюторских договоров

Мы предлагаем:

- Конкурентоспособные цены и скидки постоянным клиентам.
- Специальные условия для постоянных клиентов.
- Подбор аналогов.
- Поставку компонентов в любых объемах, удовлетворяющих вашим потребностям.
- Приемлемые сроки поставки, возможна ускоренная поставка.
- Доставку товара в любую точку России и стран СНГ.
- Комплексную поставку.
- Работу по проектам и поставку образцов.
- Формирование склада под заказчика.
- Сертификаты соответствия на поставляемую продукцию (по желанию клиента).
- Тестирование поставляемой продукции.
- Поставку компонентов, требующих военную и космическую приемку.
- Входной контроль качества.
- Наличие сертификата ISO.

В составе нашей компании организован Конструкторский отдел, призванный помогать разработчикам, и инженерам.

Конструкторский отдел помогает осуществить:

- Регистрацию проекта у производителя компонентов.
- Техническую поддержку проекта.
- Защиту от снятия компонента с производства.
- Оценку стоимости проекта по компонентам.
- Изготовление тестовой платы монтаж и пусконаладочные работы.



Тел: +7 (812) 336 43 04 (многоканальный)

Email: [org@lifeelectronics.ru](mailto:org@lifeelectronics.ru)