



Main

Range of product	Modicon M241
Product or component type	Logic controller
[Us] rated supply voltage	100...240 V AC
Discrete input number	14 discrete input including 8 fast input conforming to IEC 61131-2 Type 1
Discrete output type	Relay Transistor
Discrete output number	6 relay 4 transistor including 4 fast output
Discrete output voltage	24 V DC transistor output 5...125 V DC relay output 5...250 V AC relay output
Discrete output current	2 A with Q4...Q9 terminal(s) relay output 0.1 A with TR0...TR3 terminal(s) fast output (PTO mode) 0.5 A with TR0...TR3 terminal(s) transistor output

Complementary

Discrete I/O number	24
Number of I/O expansion module	7 (local I/O architecture) 14 (remote I/O architecture)
Supply voltage limits	85...264 V
Network frequency	50/60 Hz
Discrete input logic	Sink or source
Discrete input voltage	24 V
Discrete input voltage type	DC
Voltage state 1 guaranteed	>= 15 V input
Voltage state 0 guaranteed	<= 5 V input
Discrete input current	5 mA input
Input impedance	4.7 kOhm input
Response time	50 µs turn-on operation with I0...I13 terminal(s) input
Configurable filtering time	1 µs fast input
Discrete output logic	Positive logic (source)
Output voltage limits	125 V DC relay output 30 V DC transistor output 277 V AC relay output
Output frequency	<= 1 kHz transistor output <= 20 kHz fast output (PWM mode) <= 100 kHz fast output (PLS mode)
Accuracy	+/- 0.1 % at 0.02...0.1 kHz for fast output +/- 1 % at 0.1...1 kHz for fast output
Protection type	Short-circuit protection transistor output Short-circuit and overload protection with automatic reset transistor output Reverse polarity protection transistor output Without protection relay output
Reset time	10 ms automatic reset output 12 s automatic reset fast output
Memory capacity	8 MB program 64 MB system memory RAM
Data backed up	128 MB built-in flash memory backup of user programs
Data storage equipment	<= 16 GB SD card optional
Battery type	BR2032 lithium non-rechargeable, battery life: 4 yr

The information provided in this documentation contains general descriptions and/or technical characteristics of the performance of the products contained herein. This documentation is not intended as a substitute for and is not to be used for determining suitability or reliability of these products for specific user applications. It is the duty of any such user or integrator to perform the appropriate and complete risk analysis, evaluation and testing of the products with respect to the relevant specific application or use thereof. Neither Schneider Electric Industries SAS nor any of its affiliates or subsidiaries shall be responsible or liable for misuse of the information contained herein.

Backup time	2 years at 77 °F (25 °C)
Execution time for 1 KInstruction	0.3 ms event and periodic task 0.7 ms other instruction
Application structure	8 event tasks 4 cyclic master tasks 3 cyclic master tasks + 1 freewheeling task 8 external event tasks
Realtime clock	With
Clock drift	<= 60 s/month at 77 °F (25 °C)
Positioning functions	PTO function 4 channel(s) (positioning frequency: 100 kHz)
Counting input number	4 fast input (HSC mode) at 200 kHz 14 standard input at 1 kHz
Control signal type	A/B signal at 100 kHz fast input (HSC mode) Pulse/direction signal at 200 kHz fast input (HSC mode) Single phase signal at 200 kHz fast input (HSC mode)
Integrated connection type	USB port with connector mini B USB 2.0 Ethernet with connector RJ45 Non isolated serial link "serial 1" with connector RJ45 and interface RS232/RS485 Non isolated serial link "serial 2" with connector removable screw terminal block and interface RS485 CANopen J1939 with connector male SUB-D 9
Supply	Serial link supply "serial 1" at 5 V, <= 200 mA
Transmission rate	1.2...115.2 kbit/s (115.2 kbit/s by default) for bus length of 15 m - communication protocol: RS485 1.2...115.2 kbit/s (115.2 kbit/s by default) for bus length of 9.84 ft (3 m) - communication protocol: RS232 480 Mbit/s for bus length of 9.84 ft (3 m) - communication protocol: USB 10/100 Mbit/s - communication protocol: Ethernet 1000 kbit/s for bus length of 65.62 ft (20 m) - communication protocol: CANopen 800 kbit/s for bus length of 40 m - communication protocol: CANopen 500 kbit/s for bus length of 328.08 ft (100 m) - communication protocol: CANopen 250 kbit/s for bus length of 820.21 ft (250 m) - communication protocol: CANopen 125 kbit/s for bus length of 1640.42 ft (500 m) - communication protocol: CANopen 50 kbit/s for bus length of 3280.84 ft (1000 m) - communication protocol: CANopen 20 kbit/s for bus length of 8202.1 ft (2500 m) - communication protocol: CANopen
Communication port protocol	Modbus non isolated serial link with master/slave method
Port Ethernet	1 - 10BASE-T/100BASE-TX port with copper cable support
Communication service	Ethernet/IP adapter DHCP client IEC VAR ACCESS Modbus TCP client Modbus TCP server Modbus TCP slave device SNMP client/server FTP client/server SQL client Send and receive email from the controller based on TCP/UDP library Web server (WebVisu & XWeb system) OPC UA server DNS client
Local signalling	1 LED red module error (ERR) 1 LED green PWR 1 LED green RUN 1 LED green SD card access (SD) 1 LED red BAT 1 LED green SL1 1 LED green SL2 1 LED per channel green I/O state 1 LED red I/O error (I/O) 1 LED red bus fault on TM4 (TM4) 1 LED green Ethernet port activity 1 LED green CANopen run 1 LED green CANopen error
Electrical connection	Removable screw terminal block for inputs and outputs (pitch 5.08 mm) Removable screw terminal block for connecting the 24 V DC power supply (pitch 5.08 mm)
Cable distance between devices	Unshielded cable: <= 50 m for input Shielded cable: <= 10 m for fast input Unshielded cable: <= 50 m for output Shielded cable: <= 3 m for fast output
Insulation	500 V AC between supply and internal logic Non-insulated between supply and ground

Marking	CE
Sensor power supply	24 V DC at 400 mA supplied by the controller
Surge withstand	2 kV power lines (AC) in common mode conforming to EN/IEC 61000-4-5 2 kV relay output in common mode conforming to EN/IEC 61000-4-5 1 kV shielded cable in common mode conforming to EN/IEC 61000-4-5 1 kV power lines (AC) in differential mode conforming to EN/IEC 61000-4-5 1 kV relay output in differential mode conforming to EN/IEC 61000-4-5 1 kV input in common mode conforming to EN/IEC 61000-4-5 1 kV transistor output in common mode conforming to EN/IEC 61000-4-5
Web services	Web server
Maximum number of connections	16 connection(s) Ethernet/IP device 8 connection(s) Modbus server
CANopen feature profile	DR 303-1 DS 301 V4.02
Number of slave	63 CANopen
Mounting support	Top hat type TH35-15 rail conforming to IEC 60715 Top hat type TH35-7.5 rail conforming to IEC 60715 Plate or panel with fixing kit
Height	3.54 in (90 mm)
Depth	3.74 in (95 mm)
Width	5.91 in (150 mm)
Product weight	1.17 lb(US) (0.53 kg)

Environment

standards	UL 508 CSA C22.2 No 142 ANSI/ISA 12-12-01 UL 1604 CSA C22.2 No 213 EN/IEC 61131-2 : 2007 Marine specification (LR, ABS, DNV, GL)
product certifications	CSA CULus IACS E10 RCM
resistance to electrostatic discharge	4 kV on contact conforming to EN/IEC 61000-4-2 8 kV in air conforming to EN/IEC 61000-4-2
resistance to electromagnetic fields	9.14 V/yd (10 V/m) (80 MHz...1 GHz) conforming to EN/IEC 61000-4-3 2.74 V/yd (3 V/m) (1.4 GHz...2 GHz) conforming to EN/IEC 61000-4-3 0.91 V/yd (1 V/m) (2 GHz...3 GHz) conforming to EN/IEC 61000-4-3
resistance to fast transients	2 kV power lines conforming to EN/IEC 61000-4-4 2 kV relay output conforming to EN/IEC 61000-4-4 1 kV Ethernet line conforming to EN/IEC 61000-4-4 1 kV serial link conforming to EN/IEC 61000-4-4 1 kV input conforming to EN/IEC 61000-4-4 1 kV transistor output conforming to EN/IEC 61000-4-4
resistance to conducted disturbances	10 V (0.15...80 MHz) conforming to EN/IEC 61000-4-6 3 V (0.1...80 MHz) conforming to Marine specification (LR, ABS, DNV, GL) 10 V (spot frequency (2, 3, 4, 6.2, 8.2, 12.6, 16.5, 18.8, 22, 25 MHz)) conforming to Marine specification (LR, ABS, DNV, GL)
electromagnetic emission	Conducted emissions, test level: 120...69 dB μ V/m QP, condition of test: power lines (radio frequency: 10...150 kHz) conforming to EN/IEC 55011 Conducted emissions, test level: 63 dB μ V/m QP, condition of test: power lines (radio frequency: 1.5...30 MHz) conforming to EN/IEC 55011 Conducted emissions, test level: 79 dB μ V/m QP/66 dB μ V/m AV, condition of test: power lines (radio frequency: 0.15...0.5 MHz) conforming to EN/IEC 55011 Conducted emissions, test level: 73 dB μ V/m QP/60 dB μ V/m AV, condition of test: power lines (radio frequency: 0.5...300 MHz) conforming to EN/IEC 55011 Radiated emissions, test level: 40 dB μ V/m QP with class A, condition of test: 10 m (radio frequency: 30...230 MHz) conforming to EN/IEC 55011 Conducted emissions, test level: 79...63 dB μ V/m QP, condition of test: power lines (radio frequency: 150...1500 kHz) conforming to EN/IEC 55011 Radiated emissions, test level: 47 dB μ V/m QP with class A, condition of test: 10 m (radio frequency: 230...1000 MHz) conforming to EN/IEC 55011
immunity to microbreaks	10 ms
ambient air temperature for operation	14...131 °F (-10...55 °C) horizontal installation 14...122 °F (-10...50 °C) vertical installation
ambient air temperature for storage	-13...158 °F (-25...70 °C)

relative humidity	10...95 % without condensation in operation 10...95 % without condensation in storage
IP degree of protection	IP20 with protective cover in place
pollution degree	2
operating altitude	0...6561.68 ft (0...2000 m)
storage altitude	0...9842.52 ft (0...3000 m)
vibration resistance	3.5 mm (vibration frequency: 5...8.4 Hz) on symmetrical rail 3 gn (vibration frequency: 8.4...150 Hz) on symmetrical rail 3.5 mm (vibration frequency: 5...8.4 Hz) on panel mounting 3 gn (vibration frequency: 8.4...150 Hz) on panel mounting
shock resistance	15 gn 11 ms

Offer Sustainability

Green Premium product	Green Premium product
Compliant - since 1350 - Schneider Electric declaration of conformity	Compliant - since 1350 - Schneider Electric declaration of conformity
Reference contains SVHC above the threshold - go to CaP for more details	Reference contains SVHC above the threshold
Available	Available
Available	Available
WARNING: This product can expose you to chemicals including:	WARNING: This product can expose you to chemicals including:
Lead and lead compounds, which is known to the State of California to cause cancer and birth defects or other reproductive harm.	Lead and lead compounds, which is known to the State of California to cause cancer and birth defects or other reproductive harm.
For more information go to www.p65warnings.ca.gov	For more information go to www.p65warnings.ca.gov

Dimensions

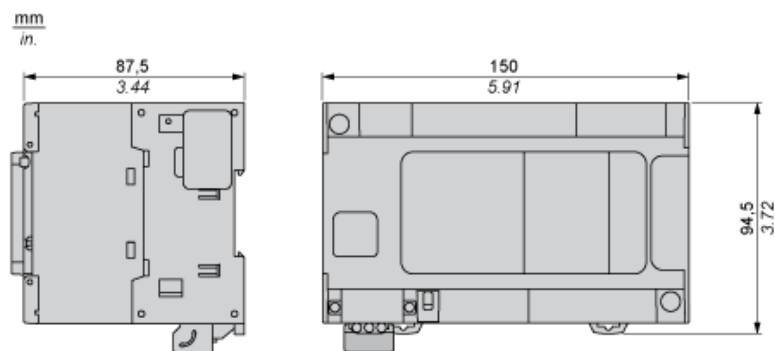

Clearance

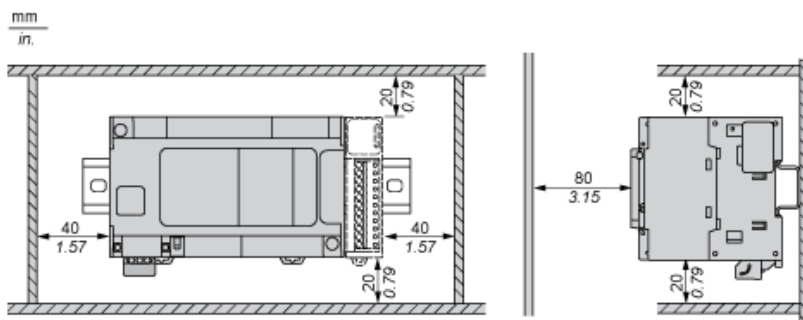

Mounting Position

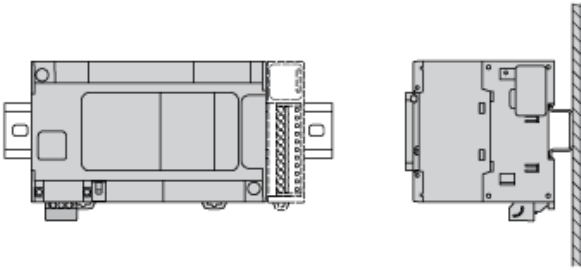

Acceptable Mounting

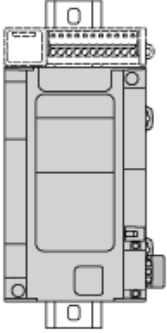

NOTE: Expansion modules must be mounted above the logic controller.

Incorrect Mounting

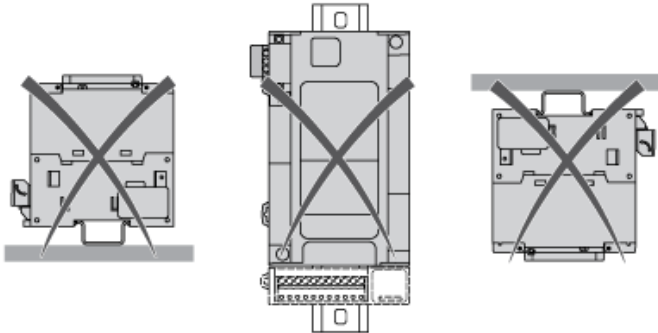

Direct Mounting On a Panel Surface

Mounting Hole Layout

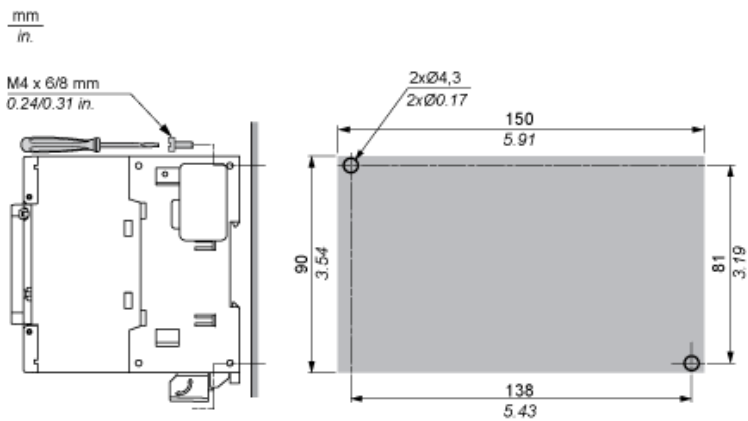

Digital Inputs

Wiring Diagram (Positive Logic)

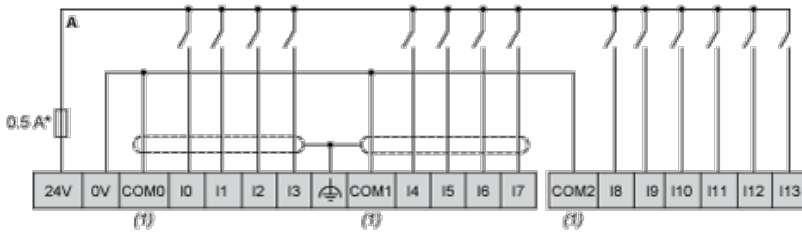

(*) : Type T fuse

(1) : The COM0, COM1 and COM2 terminals are not connected internally.

Wiring Diagram (Negative Logic)

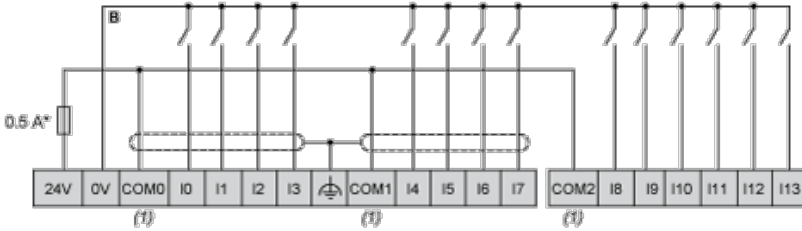

(*) : Type T fuse

(1) : The COM0, COM1 and COM2 terminals are not connected internally.

Fast Transistor Outputs

Wiring Diagram

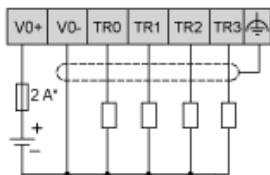

(*) : 2 A fast-blow fuse

Relay Outputs

Wiring Diagram

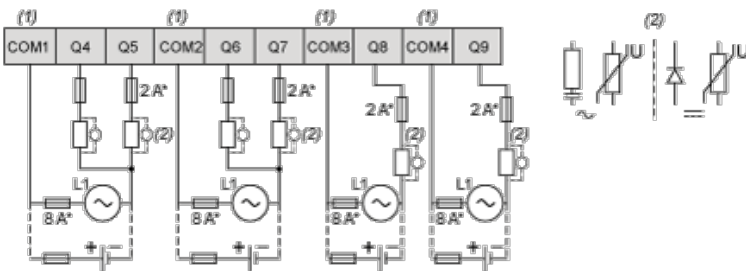

(*) : Type T fuse

(1) : The terminals COM1 to COM4 are not connected internally.

(2) : To improve the life time of the contacts, and to protect from potential inductive load damage, you must connect a free wheeling diode in parallel to each inductive DC load or an RC snubber in parallel of each inductive AC load

USB Mini-B Connection

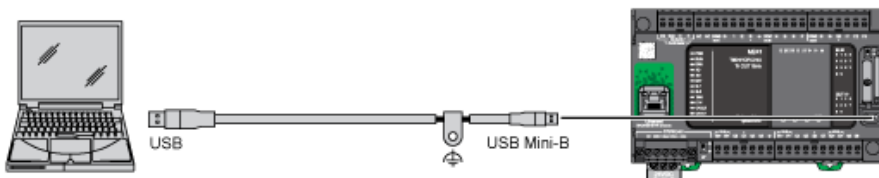

Ethernet Connection to a PC

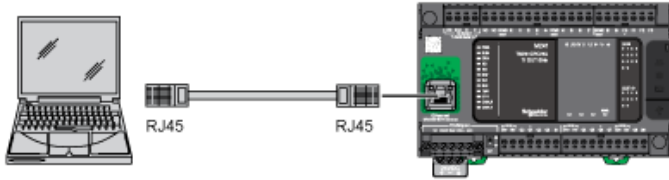

CANopen Connection

Wiring Diagram

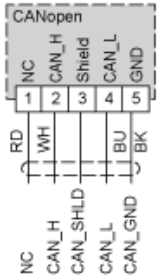

Pin	Signal	Description	Marking	Color of Cable
1	Not used	Reserved	NC	red
2	CAN_H	CAN_H bus line (dominant high)	CAN_H	white
3	CAN_SHLD	Optional CAN shield	Shield	-
4	CAN_L	CAN_L bus line (dominant low)	CAN_L	blue
5	CAN_GND	CAN Ground	GND	black

Компания «Life Electronics» занимается поставками электронных компонентов импортного и отечественного производства от производителей и со складов крупных дистрибьюторов Европы, Америки и Азии.

С конца 2013 года компания активно расширяет линейку поставок компонентов по направлению коаксиальный кабель, кварцевые генераторы и конденсаторы (керамические, пленочные, электролитические), за счёт заключения дистрибьюторских договоров

Мы предлагаем:

- Конкурентоспособные цены и скидки постоянным клиентам.
- Специальные условия для постоянных клиентов.
- Подбор аналогов.
- Поставку компонентов в любых объемах, удовлетворяющих вашим потребностям.
- Приемлемые сроки поставки, возможна ускоренная поставка.
- Доставку товара в любую точку России и стран СНГ.
- Комплексную поставку.
- Работу по проектам и поставку образцов.
- Формирование склада под заказчика.
- Сертификаты соответствия на поставляемую продукцию (по желанию клиента).
- Тестирование поставляемой продукции.
- Поставку компонентов, требующих военную и космическую приемку.
- Входной контроль качества.
- Наличие сертификата ISO.

В составе нашей компании организован Конструкторский отдел, призванный помогать разработчикам, и инженерам.

Конструкторский отдел помогает осуществить:

- Регистрацию проекта у производителя компонентов.
- Техническую поддержку проекта.
- Защиту от снятия компонента с производства.
- Оценку стоимости проекта по компонентам.
- Изготовление тестовой платы монтаж и пусконаладочные работы.



Тел: +7 (812) 336 43 04 (многоканальный)

Email: org@lifeelectronics.ru