

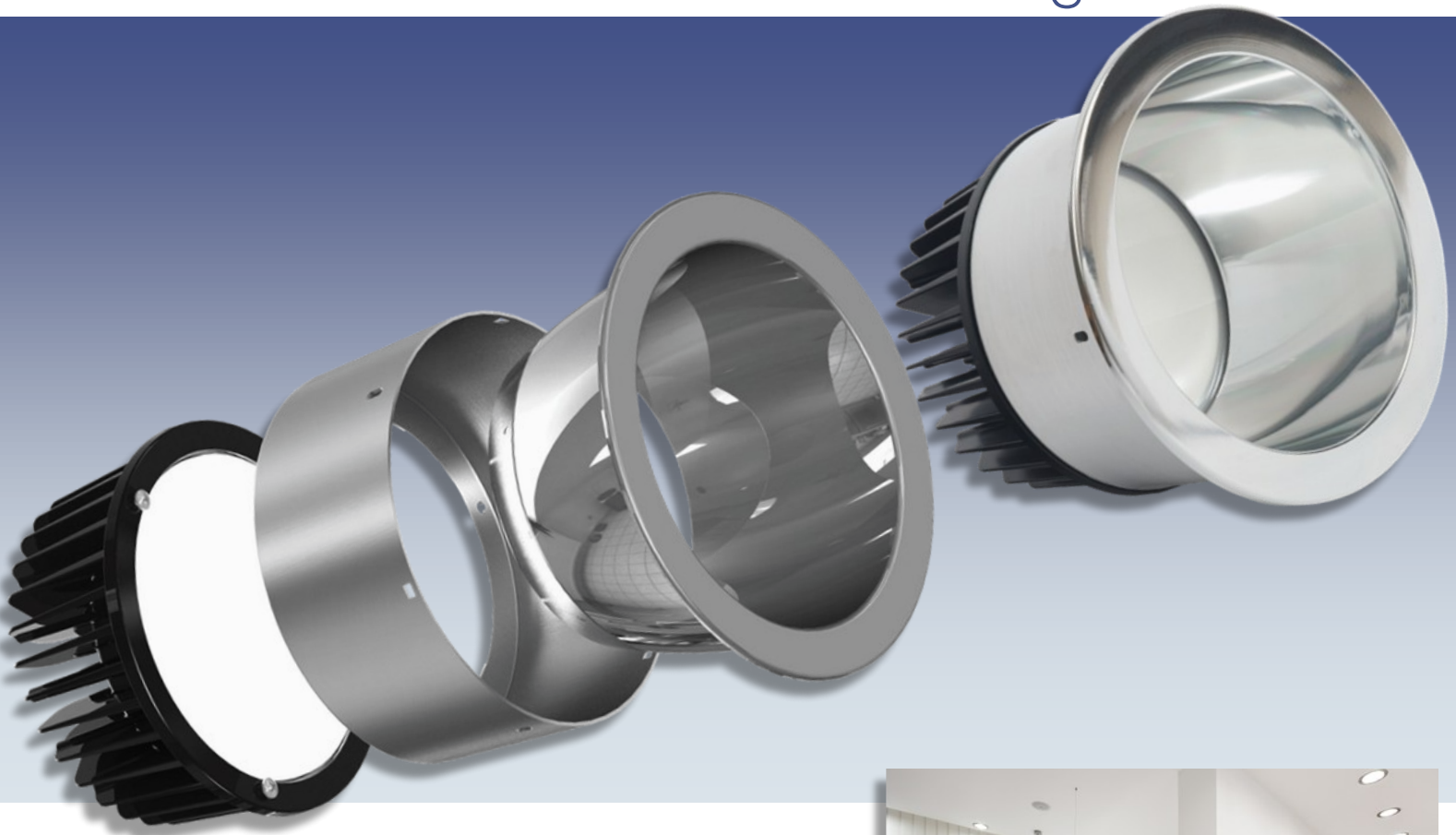

# DL2000

High Brightness  
6" LED Downlight Module



## Overview

Heatron's Innovation Series DL2000 recessed downlight module helps luminaire manufacturers expand their product lines and bring new LED fixtures to market quickly and affordably. The Innovation Series provides OEM's access to an advanced technology platform that has met LM79 approvals and is UL8750 recognized.

The advanced optical system offers a visually comfortable presentation while delivering 2100 lumens using a mere 40 watts of energy. Lighting class LEDs are used in conjunction with a mixing chamber and diffusing lens which shields direct view of LEDs. The reflector design balances the luminaire's brightness and provides a uniform, glare-free appearance.

The downlight module features an integrated cast aluminum thermal design, which efficiently transfers heat away from the LEDs using natural convection and ensures optimal performance and long life.

The DL2000 is designed to last 50,000 hours at L70 and is backed by a 5 year limited warranty.



*Transforming Your Vision  
into Higher Performance Solutions*

# DL2000 6" LED Downlight Module

## Mechanical Dimensions

### Option 1

Lens, diffuser and retaining ring

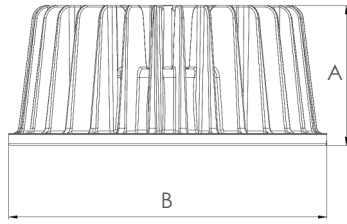

### Option 2

Lens, diffuser, lower housing, spring clips and trim ring

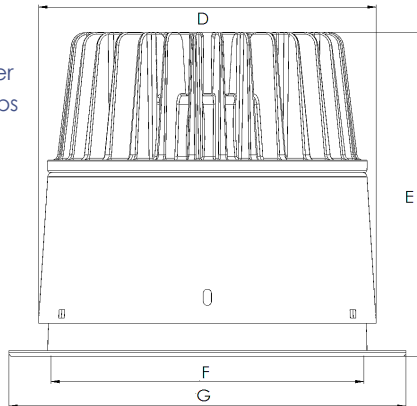

### Option 3

Lens, diffuser and lower housing

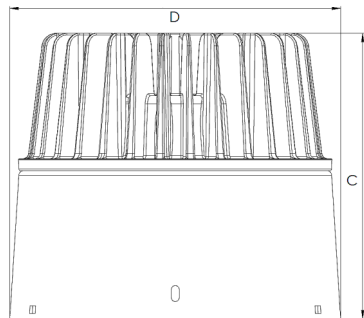

Dimensions	Inches	Millimeters
A	2.70	68.58
B	Ø 6.15	Ø 156.21
C	5.60	142.24
D	Ø 6.50	Ø 165.10
E	6.25	158.75
F	Ø 6.00	Ø 152.40
G	Ø 7.64	Ø 194.06
H	16.89	429.06

## Indoor Applications

- Retail
- Commercial
- Hospitality
- Institutions
- Health Care

## Key Features

- Light intensity exceeds a 150W incandescent or 32W Watt CFL lamp
- 80 CRI
- Optimized thermal management for maximum performance, long life and reliability
- 5 year limited warranty
- Rapid regulatory approval of final luminaire enabled by using a UL 8750 class II recognized light module
- Contains no mercury

## Product Features

### Wiring

- Side exit wiring port supplied with 15" armored aluminum BX cable
- Top exit wiring port supplied with 18" 18-gage wire with strain relief

### Lens

- Impact-resistant polycarbonate
- High lumen transmission
- Diffusing for uniform illumination

### Heat Sink

- High efficiency integrated heat sink effectively transfers heat away from the LED for reliable operation

### Weight

- 2.5 lbs. (1.13 kg)

### Testing

- Tested in accordance with IESNA LM79 by an independent laboratory

### Lifetime

- Estimated Lumen Depreciation (LM80 standard) 70% of initial lumens (L70) at 50,000 hours

## LED Module

1. Integrated cast aluminum heat sink
2. Optical mixing chamber with diffuser and lens
3. Lower housing
4. Trim ring
5. Retaining ring

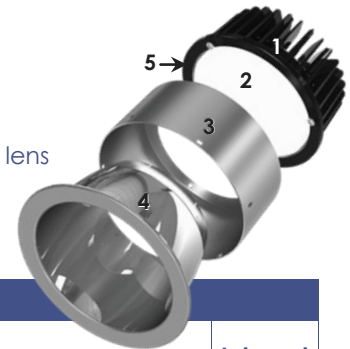

## Ordering Information Example: JDHT6R-A1430-8070-S01-NSA

Internal	Series	Internal	Color Temperature	Minimum CRI	Beam Angle	Wiring Port Location	Option	Internal
JDHT	6R	A14	30 - 3000 K 35 - 3500 K 40 - 4000 K	80 80 80	70°	T Top S Side	01 - lens, diffuser and retaining ring 02 - lens, diffuser, lower housing and trim ring 03 - lens, diffuser and lower housing	NSA

# DL2000 6" LED Downlight Module

## Technical Details

Optical Parameters	
CCT (Kelvin)	3000 K, 3500 K, 4000 K
Lumen Values	2100
CRI (min)	80
Beam Angle	70

Electrical Parameters Ta = 25°C	Nominal	Maximum
Forward Voltage Volts DC	38.10	40.80
Forward Current Amps	1.05	1.05
Power Consumption Watts (W)	38.10	40.80

Operate with a 1050mA constant current LED driver capable of operating up to 48 Watts. Actual wattage may vary by +/-10%. Driver not supplied by Heatron.

Operating Conditions	Typical	Maximum
Ambient Operating Temperature °C	25°	35°
Case Temperature °C (Tc)		70°
Storage Temperature Range °C	-25° to +50°	

Operation beyond recommended maximum levels may result in a reduction of product performance and lifetime.

Initial Footcandles			
Distance to Illuminated Plane (feet)	Footcandles Beam Center	Vertical Beam Width	Horizontal Beam Width
8'	24.6	11.2	11.2
10'	15.7	14.0	14.0
12'	10.9	16.8	16.8
14'	8.0	19.6	19.6
16'	6.2	22.4	22.4
18'	4.9	25.2	25.2
20'	3.9	28.0	28.0
22'	3.3	30.8	30.8

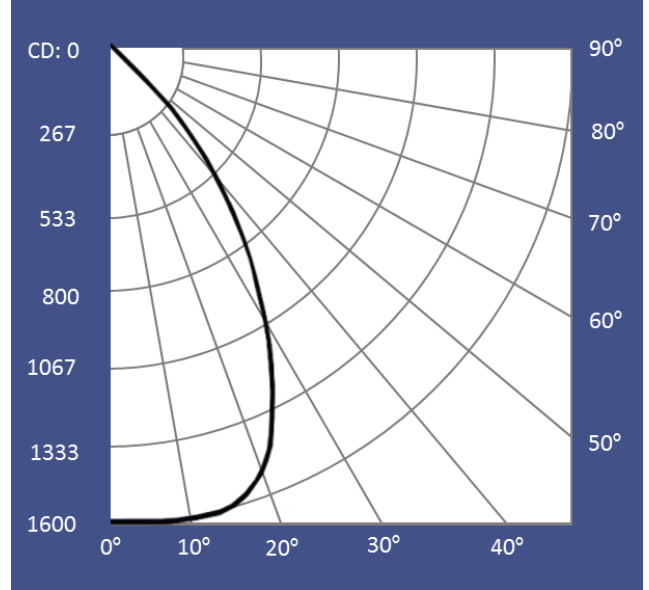

## Zonal Lumen Summary & Percentages at 25°C

Zone	Lumens	% of Luminaire
0 - 30	1212	59.8
0 - 40	1740	85.8
0 - 60	2021	99.7
0 - 90	2027	100

## Luminance Data

Candela/M <sup>2</sup>	
Angle	Average 0°
45°	27651
55°	1232
65°	544
75°	339
85°	126

## Candela Distribution

Angle	Candela
0°	1573
5°	1582
15°	1596
25°	1353
35°	845
45°	357
55°	13
65°	4
75°	2
85°	0
90°	0

## Coefficients of Utilization

Room Cavity Ratio	% Effective Ceiling Cavity Reflectance																																			
	80%						70%						50%						30%						10%						0%					
	20% Effective Floor Cavity Reflectance																																			
	70	50	30	10	70	50	30	10	70	50	30	10	70	50	30	10	70	50	30	10	70	50	30	10	70	50	30	10	70	50	30	10	0			
0	119	119	119	119	116	116	116	116	111	111	111	111	106	106	106	106	102	102	102	102	100	100	100	100	99	97	97	96	94	94	93	93	93			
1	113	110	108	105	111	108	106	103	104	102	100	100	99	97	97	96	94	94	93	93	91	91	91	91	89	89	89	89	87	87	87	87	85			
2	107	102	97	94	105	100	96	93	97	93	91	94	91	89	91	89	91	89	91	89	87	87	87	87	85	85	85	85	83	83	83	83	81			
3	101	94	89	84	99	93	88	84	90	86	82	88	84	81	88	82	80	82	80	80	78	78	78	78	76	76	76	76	74	74	74	74	72			
4	95	87	81	77	93	86	80	76	84	79	75	82	78	74	80	76	74	80	76	73	72	72	72	72	70	70	70	70	68	68	68	68	66			
5	90	81	75	70	88	80	74	70	78	73	69	76	72	68	75	71	68	75	71	68	66	66	66	66	64	64	64	64	62	62	62	62	60			
6	85	75	69	64	83	74	68	64	73	67	63	71	67	63	70	66	62	70	66	62	60	60	60	60	58	58	58	58	56	56	56	56	54			
7	80	70	63	59	79	69	63	59	68	62	58	67	62	58	66	61	58	66	61	58	56	56	56	56	54	54	54	54	52	52	52	52	50			
8	76	65	59	54	74	65	59	54	64	58	54	63	57	54	62	57	54	62	57	54	52	52	52	52	50	50	50	50	48	48	48	48	46			
9	72	61	55	50	70	61	55	50	60	54	50	59	54	50	58	53	50	58	53	50	48	48	48	48	46	46	46	46	44	44	44	44	42			
10	68	57	51	47	67	57	51	47	56	50	47	55	50	47	54	50	46	54	50	46	44	44	44	44	42	42	42	42	40	40	40	40	38			

Specifications subject to change.



### About Heatron LED Integration

Heatron LED Integration helps OEMs reduce costs, speed time to market and ensure superior quality and performance. Heatron LED Integration leverages the engineering disciplines of optical, electrical and mechanical design, with expertise in thermal management.

Offering various levels of integration ranging from design and manufacture of component level LED light engines to turnkey lighting solutions, Heatron designs for a broad range of uses, including indoor, outdoor, commercial, industrial, healthcare and transportation lighting applications.

Heatron, Inc. – *Transforming Your Vision into Higher Performance Solutions.*  
For more information about Heatron LED Integration, its products, services and manufacturing, visit [www.heatron.com](http://www.heatron.com)

3000 Wilson Avenue  
Leavenworth, KS 66048-4637 USA  
877.553.9070  
P: 1.913.651.4420 • F: 1.913.651.5352  
[www.heatron.com](http://www.heatron.com) • [sales@heatron.com](mailto:sales@heatron.com)  
ISO 9001 • Registered by Underwriters Laboratories, Inc.



Компания «Life Electronics» занимается поставками электронных компонентов импортного и отечественного производства от производителей и со складов крупных дистрибьюторов Европы, Америки и Азии.

С конца 2013 года компания активно расширяет линейку поставок компонентов по направлению коаксиальный кабель, кварцевые генераторы и конденсаторы (керамические, пленочные, электролитические), за счёт заключения дистрибьюторских договоров

Мы предлагаем:

- Конкурентоспособные цены и скидки постоянным клиентам.
- Специальные условия для постоянных клиентов.
- Подбор аналогов.
- Поставку компонентов в любых объемах, удовлетворяющих вашим потребностям.
- Приемлемые сроки поставки, возможна ускоренная поставка.
- Доставку товара в любую точку России и стран СНГ.
- Комплексную поставку.
- Работу по проектам и поставку образцов.
- Формирование склада под заказчика.
- Сертификаты соответствия на поставляемую продукцию (по желанию клиента).
- Тестирование поставляемой продукции.
- Поставку компонентов, требующих военную и космическую приемку.
- Входной контроль качества.
- Наличие сертификата ISO.

В составе нашей компании организован Конструкторский отдел, призванный помогать разработчикам, и инженерам.

Конструкторский отдел помогает осуществить:

- Регистрацию проекта у производителя компонентов.
- Техническую поддержку проекта.
- Защиту от снятия компонента с производства.
- Оценку стоимости проекта по компонентам.
- Изготовление тестовой платы монтаж и пусконаладочные работы.



Тел: +7 (812) 336 43 04 (многоканальный)

Email: [org@lifeelectronics.ru](mailto:org@lifeelectronics.ru)