

Description

ZXGD3108N8 is a 40V Active OR'ing MOSFET Controller designed for driving a very low $R_{DS(ON)}$ Power MOSFET as an ideal diode. This replaces the standard rectifier to reduce the forward voltage drop and overall increase the power transfer efficiency.

The ZXGD3108N8 can be used on both high-side and low-side power supply units (PSU) with rails up to $\pm 40V$. It enables very low $R_{DS(ON)}$ MOSFETs to operate as ideal diodes as the turn-off threshold is only $-3mV$ with $\pm 2mV$ tolerance. In the typical 12V configuration, the standby power consumption is $<5mW$ as the low quiescent supply current is $<400\mu A$. During PSU fault condition, the OR'ing Controller detects the power reduction and rapidly turns off the MOSFET in $<600ns$ to block reverse current flow and avoid the common bus voltage dropping.

Applications

Active OR'ing Controller in:

- (N+1) Redundant Power Supplies
- Telecom and Networking
- Data Centers and Servers

Features

- Active OR'ing MOSFET Controller for High- or Low-Side PSU
- Ideal Diode to Reduce Forward Voltage Drop
- $-3mV$ Typical Turn-Off Threshold with $\pm 2mV$ Tolerance
- 40V Drain Voltage Rating
- 25V V_{CC} Rating
- $<5mW$ Standby Power with Quiescent Supply Current $<400\mu A$
- $<600ns$ Turn-Off Time to Minimize Reverse Current
- **Totally Lead-Free & Fully RoHS compliant (Notes 1 & 2)**
- **Halogen and Antimony free. "Green" Device (Note 3)**

Mechanical Data

- Case: SO-8
- Case Material: Molded Plastic. "Green" Molding Compound. UL Flammability Rating 94V-0
- Moisture Sensitivity: Level 1 per J-STD-020
- Terminals: Finish – Matte Tin Plated Leads, Solderable per MIL-STD-202, Method 208 (E3)
- Weight: 0.074 grams (Approximate)

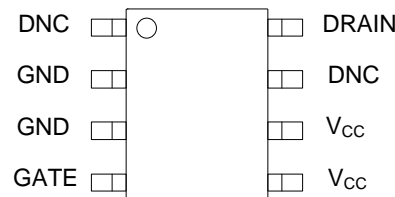
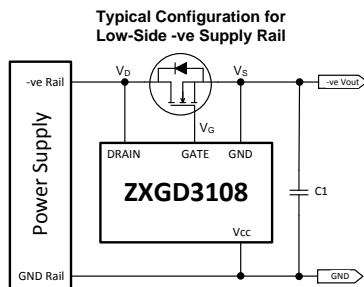

Pin Name	Pin Function
DNC	Do Not Connect
GND	Power Ground
GATE	Gate Drive
DRAIN	Drain Sense
V_{CC}	Power Supply

Ordering Information (Note 4)

Product	Marking	Reel Size (inches)	Tape Width (mm)	Quantity per Reel
ZXGD3108N8TC	ZXGD3108	13	12	2,500

- Notes:
1. No purposely added lead. Fully EU Directive 2002/95/EC (RoHS) & 2011/65/EU (RoHS 2) compliant.
 2. See http://www.diodes.com/quality/lead_free.html for more information about Diodes Incorporated's definitions of Halogen- and Antimony-free, "Green" and Lead-free.
 3. Halogen- and Antimony-free "Green" products are defined as those which contain $<900ppm$ bromine, $<900ppm$ chlorine ($<1500ppm$ total Br + Cl) and $<1000ppm$ antimony compounds.
 4. For packaging details, go to our website at <http://www.diodes.com/products/packages.html>.

Marking Information

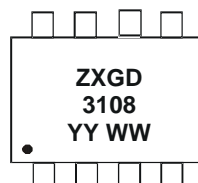

ZXGD = Product Type Marking Code, Line 1
 3108 = Product Type Marking Code, Line 2
 YY = Year (ex: 16 = 2016)
 WW = Week (01 - 53)

Absolute Maximum Ratings (Voltage relative to GND, @ $T_A = +25^\circ\text{C}$, unless otherwise specified.)

Characteristic	Symbol	Value	Unit
Supply Voltage	V_{CC}	25	V
Drain Pin Voltage	V_D	-3 to 40	V
Gate Output Voltage	V_G	-3 to $V_{CC} + 3$	V
Gate Driver Peak Source Current	I_{SOURCE}	2	A
Gate Driver Peak Sink Current	I_{SINK}	5	A

Thermal Characteristics (@ $T_A = +25^\circ\text{C}$, unless otherwise specified.)

Characteristic	Symbol	Value	Unit
Power Dissipation Linear Derating Factor	P_D	(Note 5)	490
		(Note 6)	3.92
		(Note 7)	655
		(Note 8)	5.24
		(Note 8)	720
Thermal Resistance, Junction to Ambient	$R_{\theta JA}$	(Note 5)	5.76
		(Note 6)	785
		(Note 7)	6.28
		(Note 8)	255
Thermal Resistance, Junction to Lead	$R_{\theta JL}$	191	$^\circ\text{C}/\text{W}$
Operating and Storage Temperature Range	T_J, T_{STG}	(Note 9)	173
		(Note 9)	159
		135	$^\circ\text{C}/\text{W}$
		-50 to +150	$^\circ\text{C}$

ESD Ratings (Note 10)

Characteristic	Symbol	Value	Unit	JEDEC Class
Electrostatic Discharge – Human Body Model	ESD HBM	2,000	V	2
Electrostatic Discharge – Machine Model	ESD MM	200	V	B

- Notes:
5. For a device surface mounted on minimum recommended pad layout FR4 PCB with high coverage of single sided 1oz copper, in still air conditions; the device is measured when operating in a steady-state condition.
 6. Same as Note (5), except pins 2 & 3 (GND) and pins 5 & 6 (V_{CC}) are both connected to separate 5mm x 5mm 1oz copper heat-sinks.
 7. Same as Note (6), except both heat-sinks are 10mm x 10mm.
 8. Same as Note (6), except both heat-sinks are 15mm x 15mm.
 9. Thermal resistance from junction to solder-point at the end of each lead on pins 2 & 3 (GND) and pins 5 & 6 (V_{CC}).
 10. Refer to JEDEC specification JESD22-A114 and JESD22-A11

Thermal Derating Curve

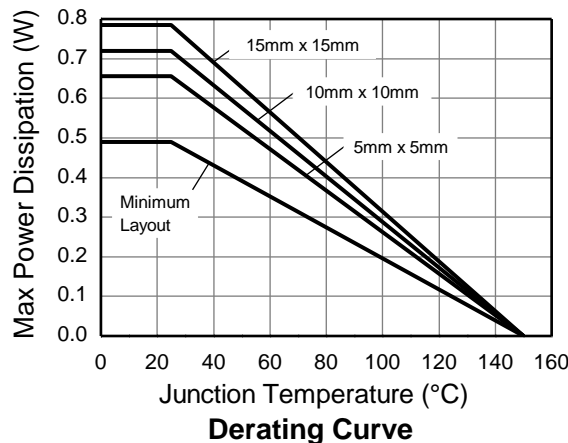

Electrical Characteristics (@ $V_{CC} = 12V$, $T_A = +25^\circ C$, unless otherwise specified.)

Characteristic	Symbol	Min	Typ	Max	Unit	Test Condition	
Input Supply							
Operating Supply Voltage	V_{CC}	4	—	20	V		
Quiescent Current	I_Q	—	200	400	μA	$-0.6V \leq V_{DRAIN} \leq 30V$	
Gate Driver							
Gate Peak Source Current	I_{SOURCE}	—	0.66	—	A	$C_L = 47nF$	
Gate Peak Sink Current	I_{SINK}	—	3.3	—			
Gate Peak Source Current (Note 11)	I_{SOURCE}	1	—	—	A	$V_{GATE} = 5V$ & $V_{DRAIN} = -1V$	
Gate Peak Sink Current (Note 11)	I_{SINK}	1.8	—	—	A	$V_{GATE} = 5V$ & $V_{DRAIN} = 1V$	
Detector Under DC Condition							
Turn-Off Threshold Voltage	V_T	-5	-3	-1	mV	$V_G \leq 1V$	
Gate Output Voltage	$V_{G(OFF)}$	—	0.1	0.3	V	Load: 50nF Capacitor Connected in Parallel with 50k Ω Resistor	
	V_G	10.5	10.9				$V_{DRAIN} \geq 0mV$
	$V_{G(OFF)}$	—	0.1	0.3			$V_{DRAIN} = -8mV$
	V_G	2.5	2.9	—			$V_{DRAIN} \geq 0mV$ & $V_{CC} = 4V$
	$V_{G(OFF)}$	—	0.1	0.3			$V_{DRAIN} = -8mV$ & $V_{CC} = 4V$
	V_G	18.5	18.8	—			$V_{DRAIN} \geq -8mV$ & $V_{CC} = 20V$
						$V_{DRAIN} = -8mV$ & $V_{CC} = 20V$	
Switching Performance							
Turn-On Propagation Delay	$t_{D(RISE)}$	—	400	—	ns	$C_L = 47nF$ Rise and Fall Measured 10% to 90% Refer to Application Test Circuit Below	
Gate Rise Time	t_R	—	695	—			
Turn-Off Propagation Delay	$t_{D(FALL)}$	—	400	—			
Gate Fall Time	t_F	—	131	—			

Note: 11. Measured under pulsed conditions. Pulse width = 300 μs . Duty cycle $\leq 2\%$.

Pin Functions

Pin Number	Pin Name	Pin Function and Description
1, 7	DNC	Do Not Connect Leave pin floating.
2, 3	GND	Ground Connect this pin to the MOSFET source terminal and ground reference point.
4	GATE	Gate Drive This pin sources (I_{SOURCE}) and sinks (I_{SINK}) current into the MOSFET gate. The turn-on time of the MOSFET can be programmed through an external gate resistor (R_G).
5, 6	V_{CC}	Power Supply This supply pin should be closely decoupled to ground with a X7R type capacitor.
8	DRAIN	Drain Sense Connect this pin to the MOSFET drain terminal to detect the change in drain-source voltage.

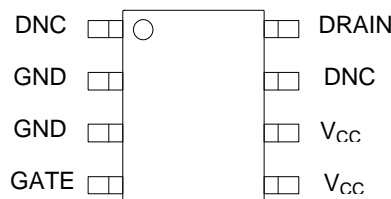

Layout Considerations

The GATE Pin should be close to the MOSFET gate to minimize trace resistance and inductance to maximize switching performance. While the V_{CC} to GND Pin needs an X7R type capacitor closely decoupling the supply. Trace widths should be maximized in the high current paths through the MOSFET and ground return loop in order to minimize the effects of circuit resistance and inductance. The ground return loop should also be as short as possible.

For thermal consideration, the main heat path is from pins 2 and 3 (GND), and pins 5 and 6 (V_{CC}). For best thermal performance, connect the copper area to pins 2 and 3 (GND), and pins 5 and 6 (V_{CC}) should be maximized.

Active OR'ing or (N+1) Redundancy Application

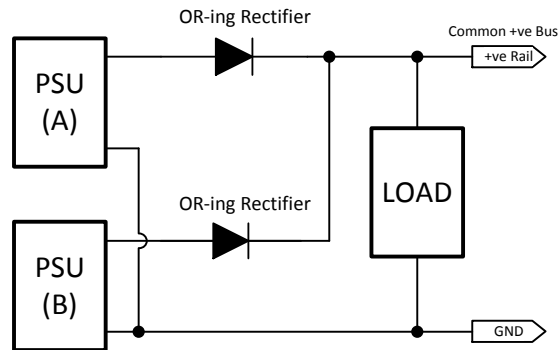

Critical systems require fault-tolerant power supply that can be achieved by paralleling two or more PSUs into (N+1) redundancy configuration. During normal operation, usually all PSUs equally share the load for maximum reliability. If one of the PSU is unplugged or fails, then the other PSUs fully support the load. To avoid the faulty PSU from affecting the common bus, then an OR-ing rectifier blocks the reverse current flow into the faulty PSU. Likewise during hot-swapping, the OR'ing rectifiers isolate a PSU's discharged output capacitors from the common bus.

As the load current is in the tens of amps then a standard rectifier has a significant forward voltage drop. This both wastes power and significantly drops the potential on low voltage rails. Hence, very low $R_{DS(ON)}$ Power MOSFETs can replace the standard rectifiers and the ZXGD3108 controls the MOSFET as an ideal diode.

Functional Block Diagram

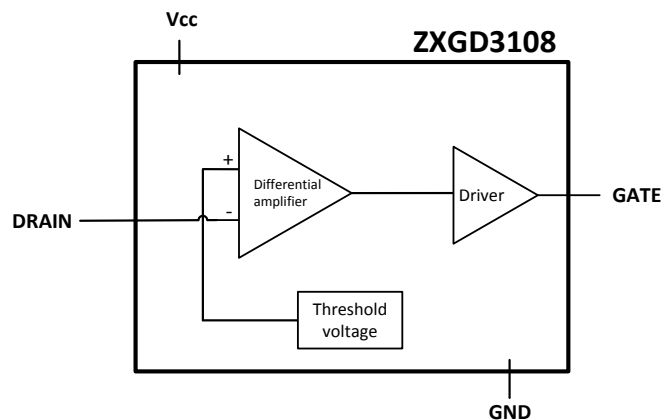

The device is comprised of a differential amplifier and high current driver. The differential amplifier acts as a detector and monitors the DRAIN-to-GND Pin voltage difference. When this difference is less than the threshold voltage (V_T), then a positive output voltage approaching V_{CC} is given on the GATE Pin. Conversely, when the DRAIN-to-GND Pin voltage difference is greater than V_T , then the GATE Pin voltage is rapidly reduced towards the GND voltage.

Typical Application Circuits

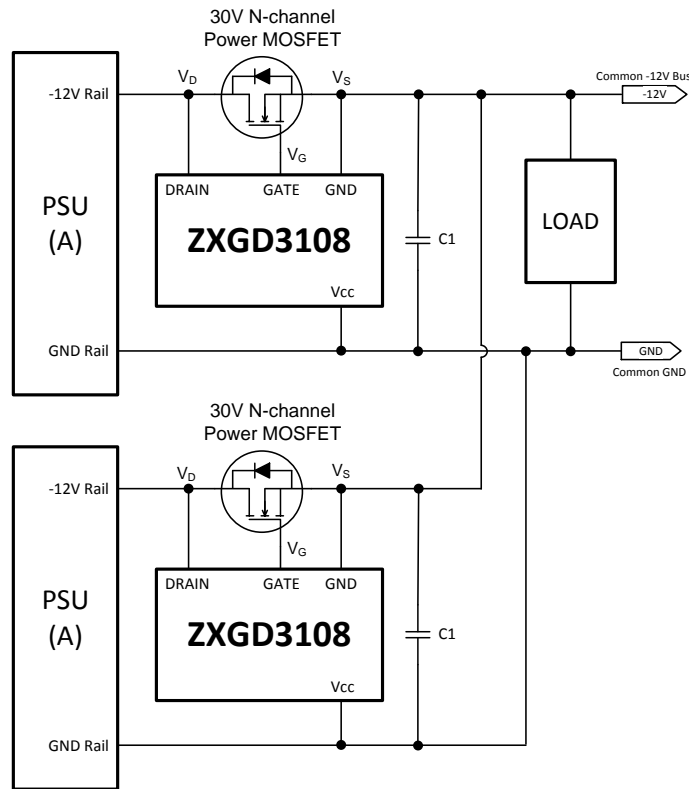

Focus Application of the ZXGD3108 OR'ing Controller is for Redundant Low-Side -12V Power Supply Rail

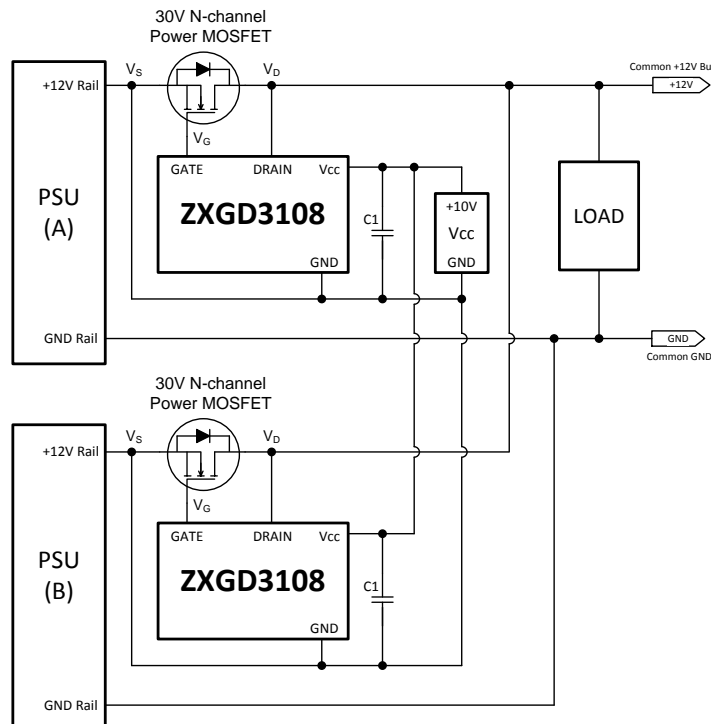

Example of the ZXGD3108 OR'ing Controller in a Redundant High-Side +12V Power Supply Rail with V_{CC} Supply

Operation in Typical Application

The ZXGD3108 operation is described step-by-step with reference to the typical application circuits and the timing diagram below:

1. The ZXGD3108 differential amplifier monitors the MOSFET's drain-source voltage (V_{DS}).
2. At system start up, the MOSFET body diode is forced to conduct current from the input PSU to the load and V_{DS} is approximately $-0.6V$ as measured by the differential amplifier between DRAIN-to-GND pins.
3. As $V_{DS} < V_T$ (threshold voltage), then the differential amplifier outputs a positive voltage approaching V_{CC} with respect to GND. This feeds the driver stage from which the GATE Pin voltage rises towards V_{CC} .
4. The sourcing current out of the GATE Pin drives the MOSFET gate to enhance the channel and turn it on.
5. If a short condition occurs on the input PSU, it causes the MOSFET V_{DS} to increase.
6. When $V_{DS} > V_T$, then the differential amplifier's output goes to GND and the driver stage rapidly pulls the GATE Pin voltage to GND, turning off the MOSFET channel. This prevents high reverse current flow from the load to the PSU which could pull down the common bus voltage causing catastrophic system failure.

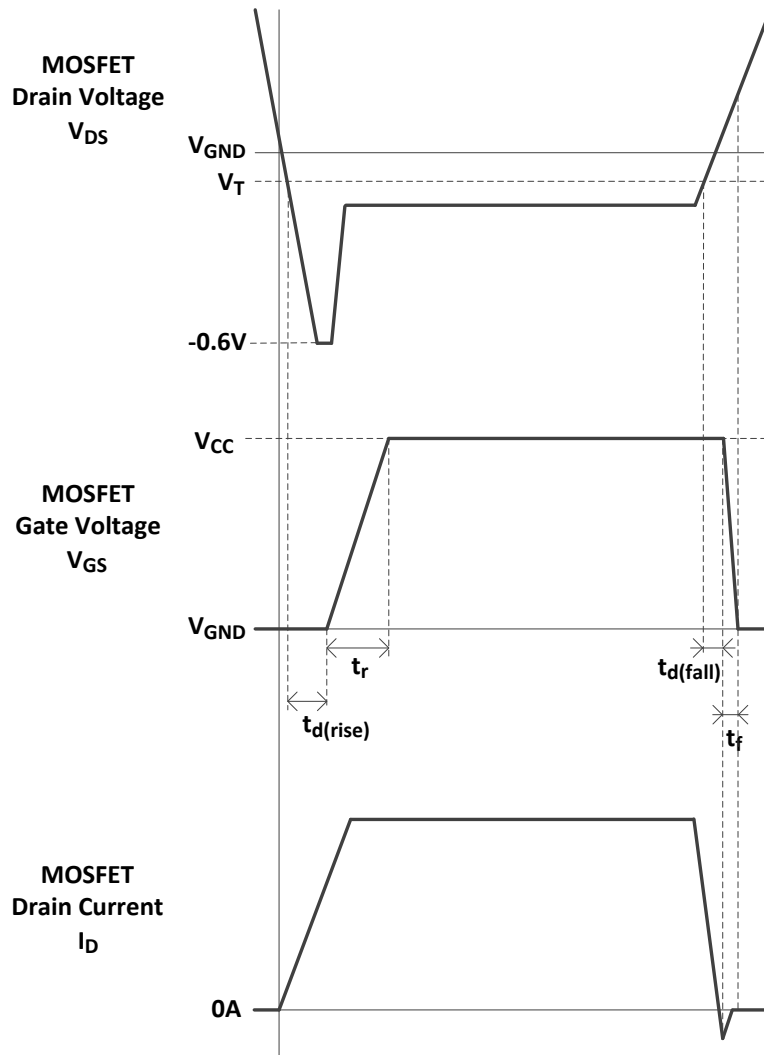

Typical Electrical Characteristics (@T_A = +25°C, unless otherwise specified.)

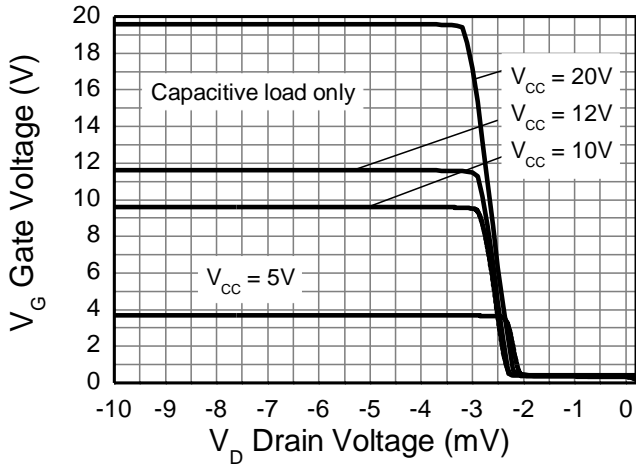

Transfer Characteristic

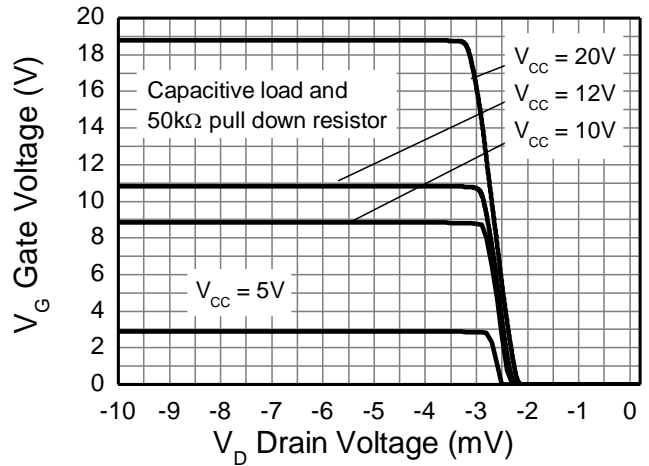

Transfer Characteristic

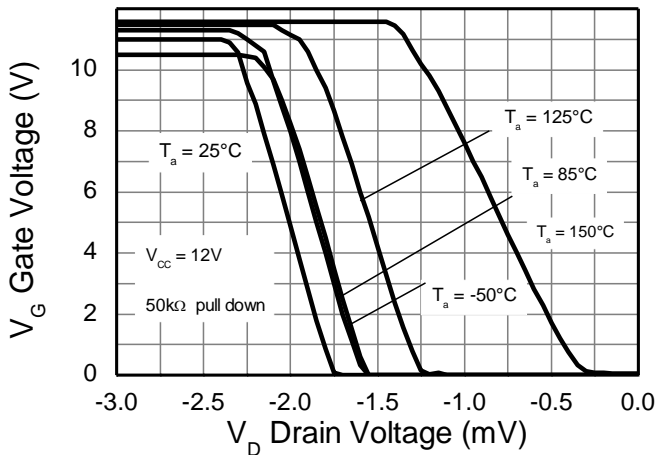

Transfer Characteristic

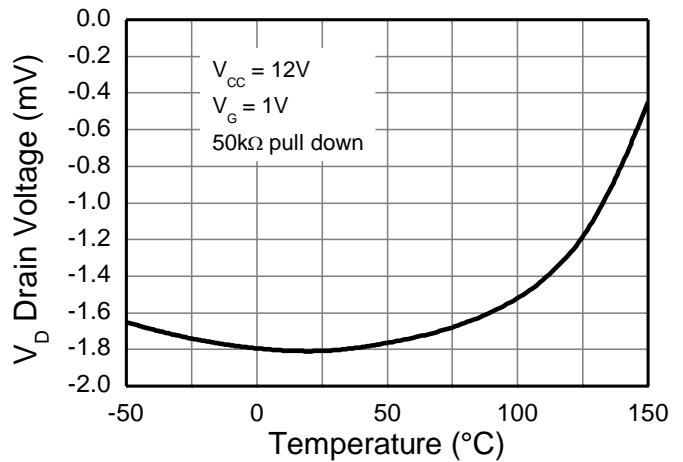

Drain Sense Voltage vs Temperature

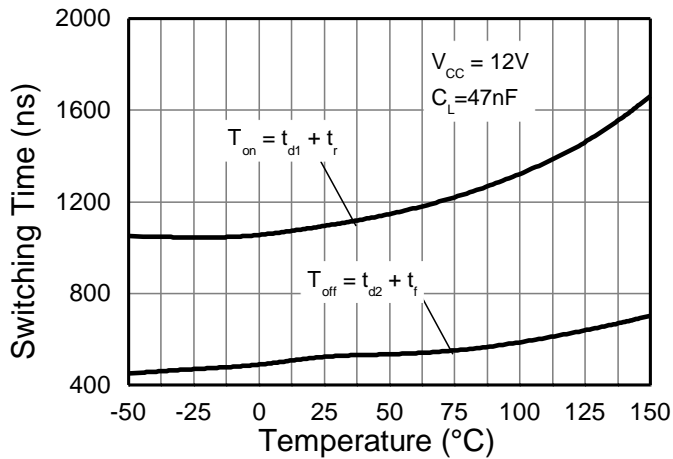

Switching vs Temperature

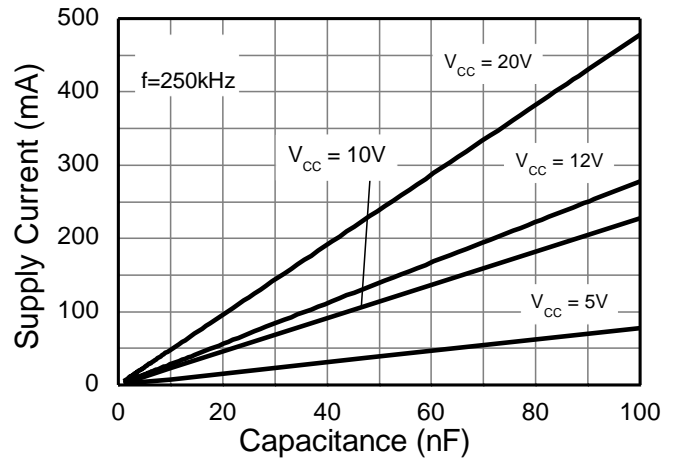

Supply Current vs Capacitive Load

Typical Electrical Characteristics (Continued) (@T_A = +25°C, unless otherwise specified.)

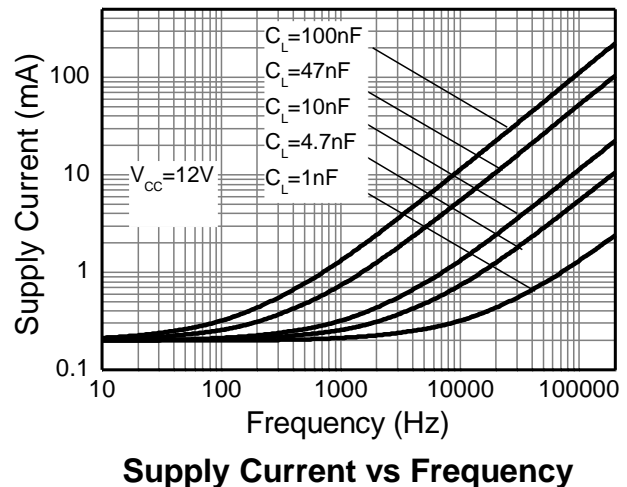
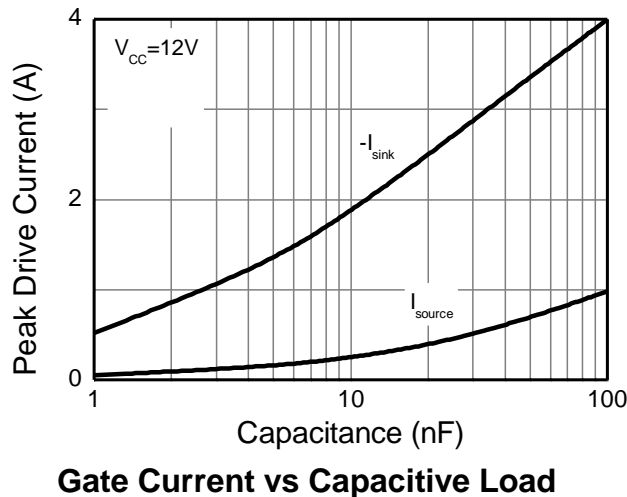
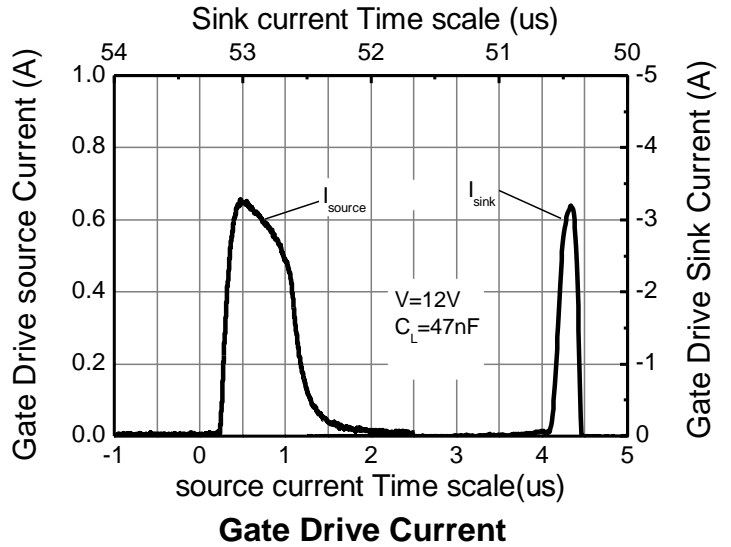
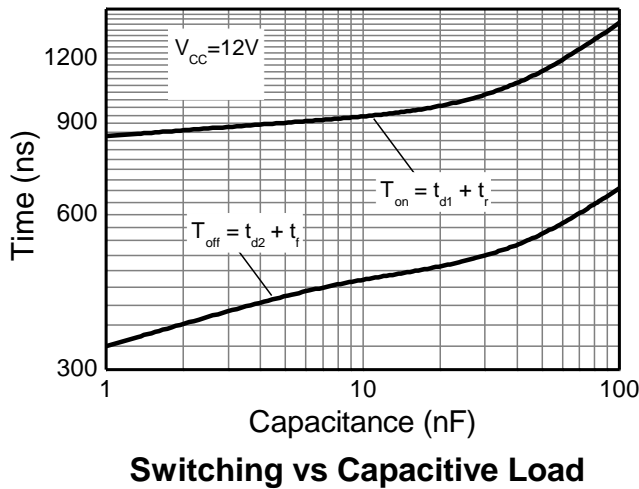
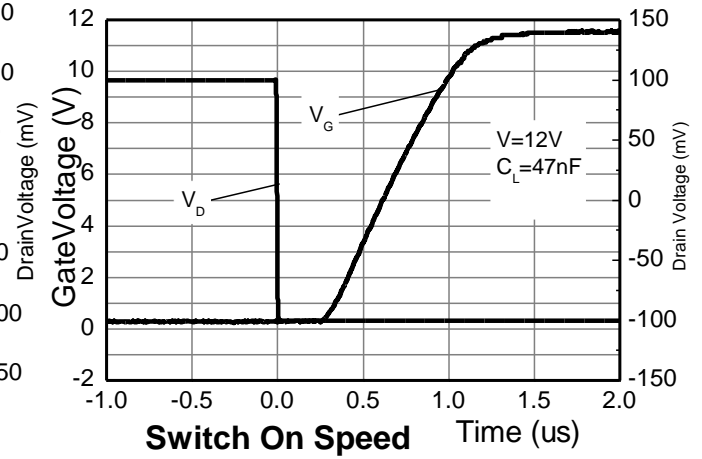
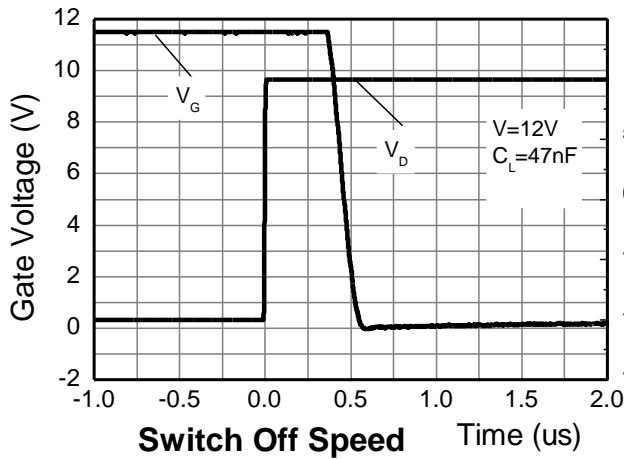

Package Outline Dimensions

Please see AP02001 at http://www.diodes.com/_files/datasheets/ap02001.pdf for the latest version.

SO-8

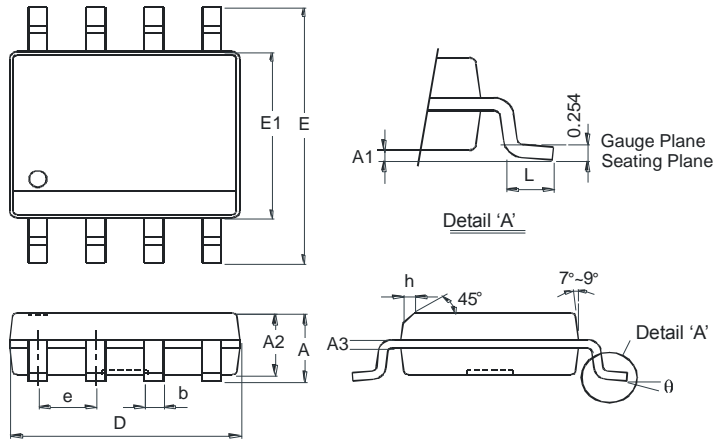

SO-8		
Dim	Min	Max
A	-	1.75
A1	0.10	0.20
A2	1.30	1.50
A3	0.15	0.25
b	0.3	0.5
D	4.85	4.95
E	5.90	6.10
E1	3.85	3.95
e	1.27 Typ	
h	-	0.35
L	0.62	0.82
θ	0°	8°
All Dimensions in mm		

Suggested Pad Layout

Please see AP02001 at http://www.diodes.com/_files/datasheets/ap02001.pdf for the latest version.

SO-8

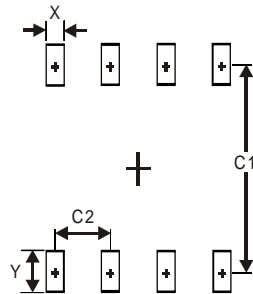

Dimensions	Value (in mm)
X	0.60
Y	1.55
C1	5.4
C2	1.27

IMPORTANT NOTICE

DIODES INCORPORATED MAKES NO WARRANTY OF ANY KIND, EXPRESS OR IMPLIED, WITH REGARDS TO THIS DOCUMENT, INCLUDING, BUT NOT LIMITED TO, THE IMPLIED WARRANTIES OF MERCHANTABILITY AND FITNESS FOR A PARTICULAR PURPOSE (AND THEIR EQUIVALENTS UNDER THE LAWS OF ANY JURISDICTION).

Diodes Incorporated and its subsidiaries reserve the right to make modifications, enhancements, improvements, corrections or other changes without further notice to this document and any product described herein. Diodes Incorporated does not assume any liability arising out of the application or use of this document or any product described herein; neither does Diodes Incorporated convey any license under its patent or trademark rights, nor the rights of others. Any Customer or user of this document or products described herein in such applications shall assume all risks of such use and will agree to hold Diodes Incorporated and all the companies whose products are represented on Diodes Incorporated website, harmless against all damages.

Diodes Incorporated does not warrant or accept any liability whatsoever in respect of any products purchased through unauthorized sales channel. Should Customers purchase or use Diodes Incorporated products for any unintended or unauthorized application, Customers shall indemnify and hold Diodes Incorporated and its representatives harmless against all claims, damages, expenses, and attorney fees arising out of, directly or indirectly, any claim of personal injury or death associated with such unintended or unauthorized application.

Products described herein may be covered by one or more United States, international or foreign patents pending. Product names and markings noted herein may also be covered by one or more United States, international or foreign trademarks.

This document is written in English but may be translated into multiple languages for reference. Only the English version of this document is the final and determinative format released by Diodes Incorporated.

LIFE SUPPORT

Diodes Incorporated products are specifically not authorized for use as critical components in life support devices or systems without the express written approval of the Chief Executive Officer of Diodes Incorporated. As used herein:

A. Life support devices or systems are devices or systems which:

1. are intended to implant into the body, or
2. support or sustain life and whose failure to perform when properly used in accordance with instructions for use provided in the labeling can be reasonably expected to result in significant injury to the user.

B. A critical component is any component in a life support device or system whose failure to perform can be reasonably expected to cause the failure of the life support device or to affect its safety or effectiveness.

Customers represent that they have all necessary expertise in the safety and regulatory ramifications of their life support devices or systems, and acknowledge and agree that they are solely responsible for all legal, regulatory and safety-related requirements concerning their products and any use of Diodes Incorporated products in such safety-critical, life support devices or systems, notwithstanding any devices- or systems-related information or support that may be provided by Diodes Incorporated. Further, Customers must fully indemnify Diodes Incorporated and its representatives against any damages arising out of the use of Diodes Incorporated products in such safety-critical, life support devices or systems.

Copyright © 2016, Diodes Incorporated

www.diodes.com

Компания «Life Electronics» занимается поставками электронных компонентов импортного и отечественного производства от производителей и со складов крупных дистрибьюторов Европы, Америки и Азии.

С конца 2013 года компания активно расширяет линейку поставок компонентов по направлению коаксиальный кабель, кварцевые генераторы и конденсаторы (керамические, пленочные, электролитические), за счёт заключения дистрибьюторских договоров

Мы предлагаем:

- Конкурентоспособные цены и скидки постоянным клиентам.
- Специальные условия для постоянных клиентов.
- Подбор аналогов.
- Поставку компонентов в любых объемах, удовлетворяющих вашим потребностям.
- Приемлемые сроки поставки, возможна ускоренная поставка.
- Доставку товара в любую точку России и стран СНГ.
- Комплексную поставку.
- Работу по проектам и поставку образцов.
- Формирование склада под заказчика.
- Сертификаты соответствия на поставляемую продукцию (по желанию клиента).
- Тестирование поставляемой продукции.
- Поставку компонентов, требующих военную и космическую приемку.
- Входной контроль качества.
- Наличие сертификата ISO.

В составе нашей компании организован Конструкторский отдел, призванный помогать разработчикам, и инженерам.

Конструкторский отдел помогает осуществить:

- Регистрацию проекта у производителя компонентов.
- Техническую поддержку проекта.
- Защиту от снятия компонента с производства.
- Оценку стоимости проекта по компонентам.
- Изготовление тестовой платы монтаж и пусконаладочные работы.



Тел: +7 (812) 336 43 04 (многоканальный)

Email: org@lifeelectronics.ru