

REVISIONS				
P.	LTN	DESCRIPTION	DATE	APPV
B9	ECR-16-007656		26MAY2016	SS RR
B10	ECR-16-010175		14JUL2016	KD RR
B11	ECR-16-016334		17NOV2016	FV RR
B12	ECR-17-009651		19JUL2017	RS DC

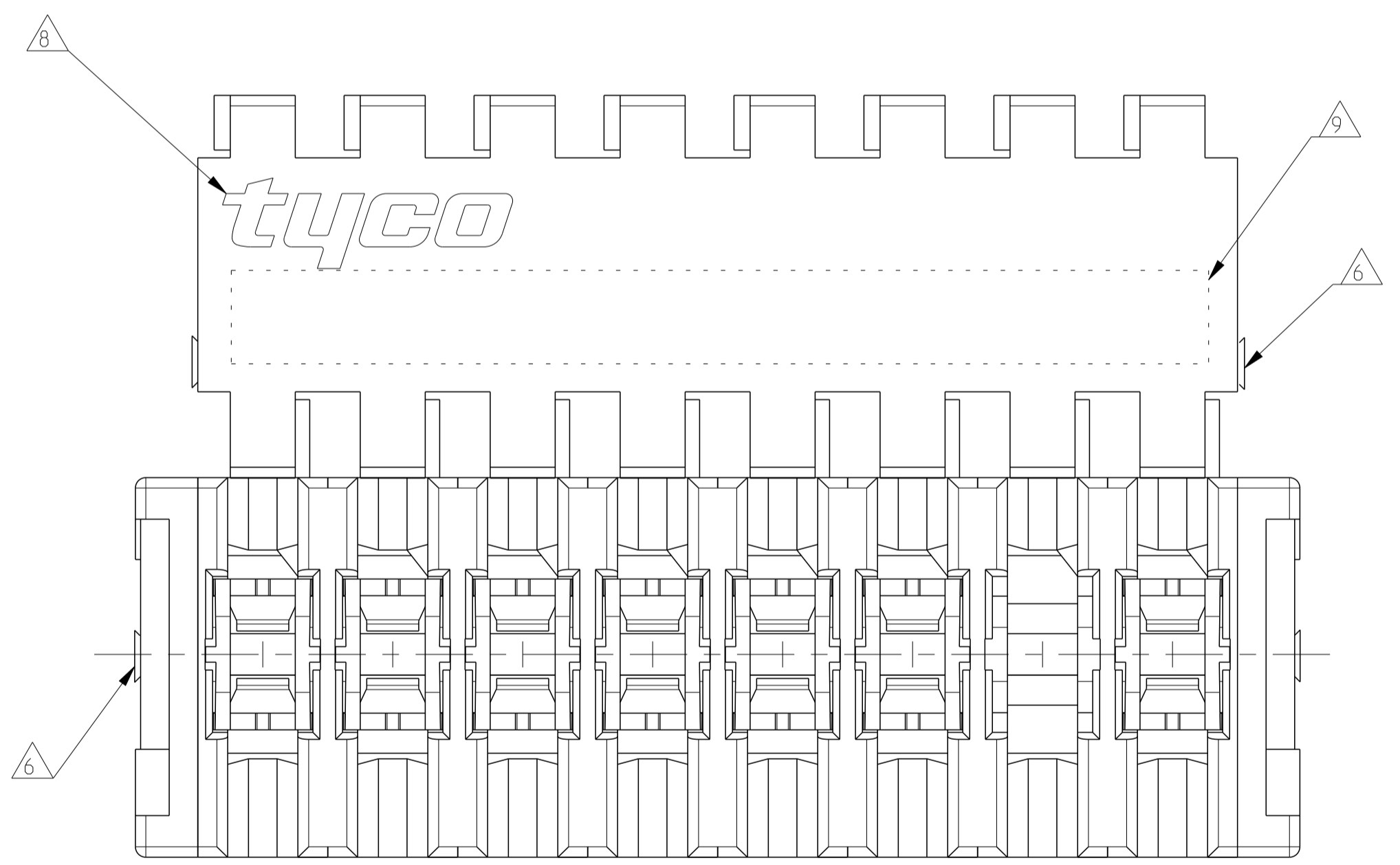
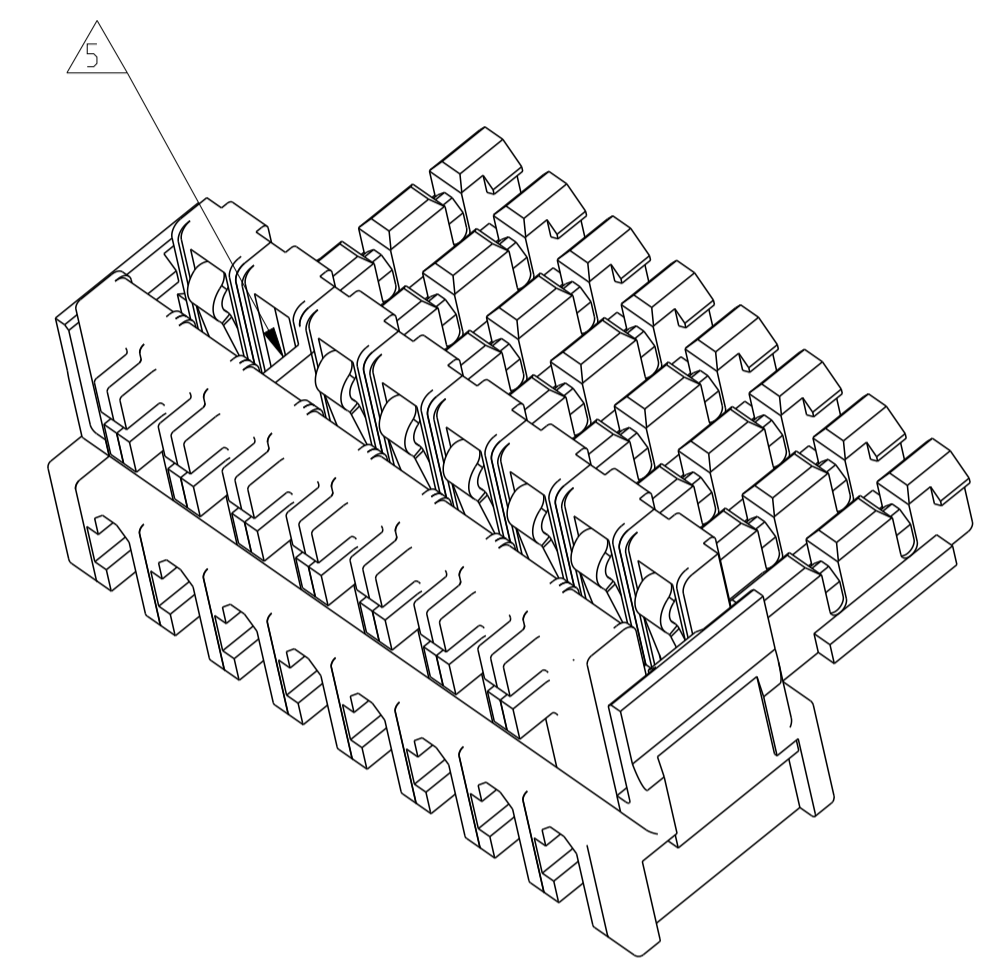
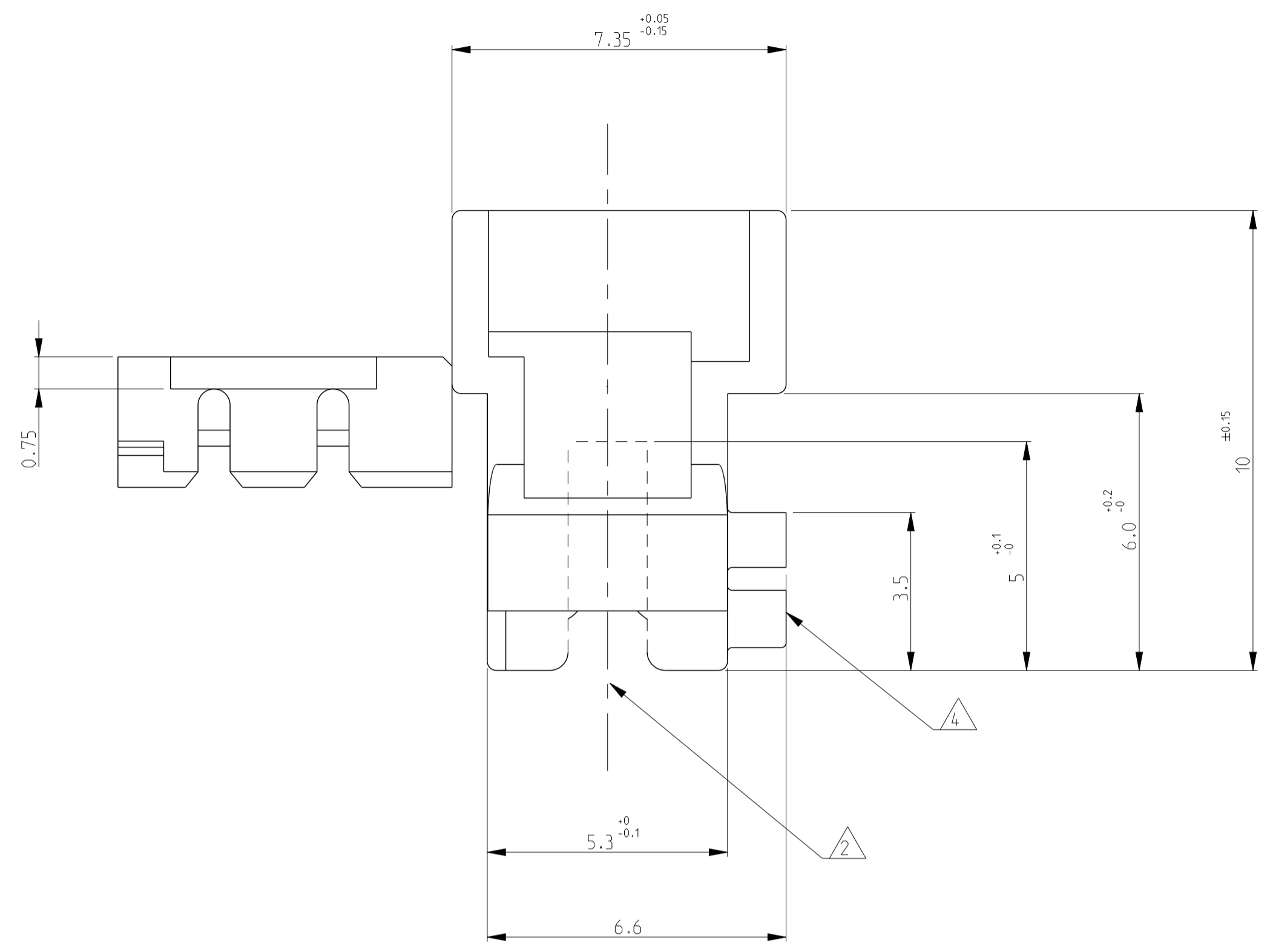
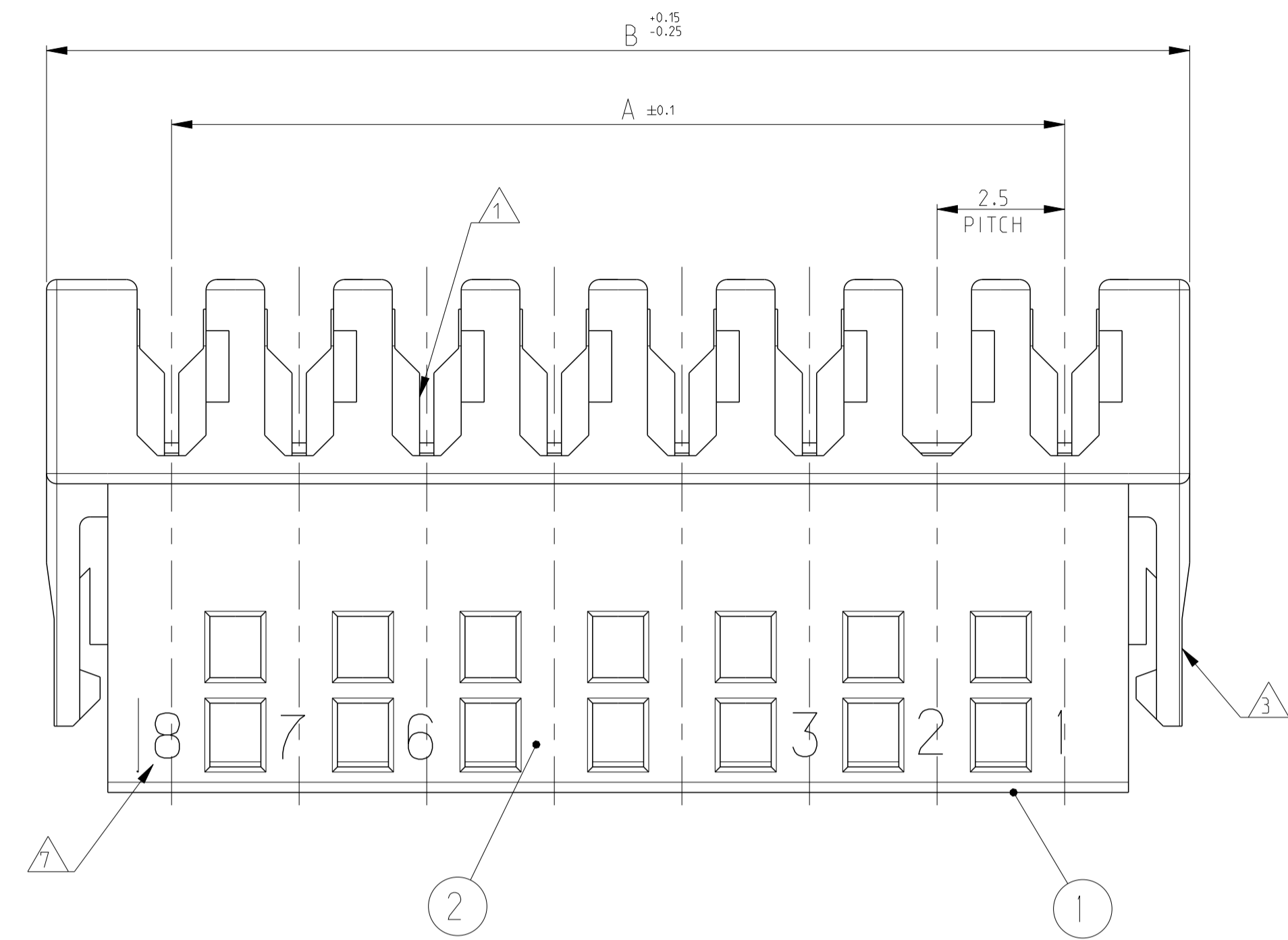

- ① WIRE RANGE : STRANDED 0.22-0.35 mm<sup>2</sup> (INS. DIA. 1.30±0.1)
- ② MATING PART: P.C.B. EDGE, DOUBLE SIDE, THK 1.5 (COPPER CLADDING INCLUDED)
- ③ SIDE LOCKING DEVICE
- ④ KEYING RIBS TO BE REMOVED BY TERMINATION MACHINE
- ⑤ POLARIZATION RIBS BETWEEN CAVITIES
- ⑥ CUT OFF DIMENSION DUE TO PRODUCTION PROCESS
- ⑦ CIRCUIT No. IDENTIFICATION
- ⑧ TE TRADEMARK (OPTIONAL POSITION)
- ⑨ TAMPOGRAPHIC COLOUR CODE AREA (P/Ns IDENTIFICATION BEFORE CRIMPING AREA)
- ⑩ FOR PCB LAYOUT, SEE SHEET 2  
FOR CONNECTION VIEW LAYOUT, SEE SHEET 2
- ⑪ PRELIMINARY NOT YET RELEASED FOR PRODUCTION
- ⑫ PBT GF
- ⑬ PBT GF, UL94-V0 & GWEPT 750 NO-FLAME, NATURAL

COLOUR CODE	POLARIZ. RIB POS.	CONTACT LOADING	HSG POS.	DIM.A	DIM.B	TE P/N	TE P/N
GREEN	13/14	SELECTIVELY 1.3,4,6,8,9,10,11,12,13,14	14	32.5	37.4	5-284866-4	1-2311508-4
BLUE		SELECTIVELY 1.3,4,6,11,12,13,14				1-284866-4	2311508-4
BLUE	2/3	SELECTIVELY 1.3,4,6,7,9,11,12	12	27.5	32.4	1-284866-2	2311508-2
OBSOLETE	2/3	SELECTIVELY 1.2,3,4,5,6,7,8,10	10	22.5	27.4	<del>1-284866-0</del>	-
GRAY	3/4	SELECTIVELY 1.3,4,6,8,9				7-284866-9	8-2311507-9
RED	4/5	SELECTIVELY 1,2,4,6,8,9				8-284866-9	7-2311507-9
GREEN		SELECTIVELY 1,2,4,6,7,9				1-284866-9	6-2311507-9
BLACK		SELECTIVELY 1,3,5,7,8,9	9	20.0	24.9	6-284866-9	5-2311507-9
ORANGE		SELECTIVELY 1,2,3,5,7,9				5-284866-9	4-2311507-9
BROWN	2/3	SELECTIVELY 1,3,4,6,8,9				4-284866-9	3-2311507-9
RED		SELECTIVELY 1,3,5,6,7,9				3-284866-9	2-2311507-9
GREEN		SELECTIVELY 1,3,4,5,6,7,8,9				2-284866-9	1-2311507-9
BLUE		SELECTIVELY 1,3,4,6,7,9				0-284866-9	2311507-9
BROWN		SELECTIVELY 1,2,3,4,6,8				4-284866-8	3-2311507-8
RED	2/3	SELECTIVELY 1,3,5,6,7,8	8	17.5	22.4	3-284866-8	2-2311507-8
GREEN		SELECTIVELY 1,3,4,5,6,7,8				2-284866-8	1-2311507-8
BLUE		SELECTIVELY 1,3,4,6,7,8				0-284866-8	2311507-8
BLUE		SELECTIVELY 1,3,5,7				1-284866-7	1-2311507-7
BLUE	2/3	SELECTIVELY 1,3,5,6,7	7	15.0	19.9	0-284866-7	2311507-7
BLACK	2/3	SELECTIVELY 1,3,4,6				4-284866-6	2-2311507-6
GREEN	4/5	SELECTIVELY 1,2,4,6	6	12.5	17.4	2-284866-6	1-2311507-6
BLUE	2/3	SELECTIVELY 1,3,5,6				0-284866-6	2311507-6
ORANGE	1/2	SELECTIVELY 3,4,5				4-284866-5	3-2311507-5
GREEN		SELECTIVELY 1,2,3,5				3-284866-5	2-2311507-5
BLUE	3/4	SELECTIVELY 1,3,4,5	5	10.0	14.9	2-284866-5	1-2311507-5
RED	2/3	SELECTIVELY 2,4				0-284866-5	2311507-5
GREEN	N/A	SELECTIVELY 1,2,4	4	7.5	12.4	2-284866-4	2311507-4
GREEN	1/2	SELECTIVELY 1,3	3	5.0	9.9	2-284866-3	1-2311507-3
BLUE	2/3	SELECTIVELY 1,3				0-284866-3	2311507-3

P/N 2-284866-8 AS SHOWN

PH. BRONZE, TIN PLATED	IDC RECEPTACLE CONTACT	2	THIS DRAWING IS A CONTROLLED DOCUMENT. DIMENSIONS: mm TOLERANCES UNLESS OTHERWISE SPECIFIED: 0 PLC ±0.2 1 PLC ±0.2 2 PLC ±0.2 3 PLC ±0.2 4 PLC ±0.2 ANGLES ±1° FINISH	OWN R. FABRIS 03JUL2002	<b>STE</b> TE Connectivity NAME DUOPLUG 2.5 FEMALE CONN., SIDE LOCKING, KEYED (SELECTIVELY LOADED CONTACTS) PRODUCT SPEC 108-20238 APPLICATION SPEC 116-18049-1 WEIGHT - CUSTOMER DRAWING
PBT GLASS FIBER FILLED	FEMALE HOUSING	1		REVISIONE DELL'ASSEMBLATO (REVISION OF EACH ASSY NO) ELENCO DEI COMPONENTI (PARTS LIST)	

# PCB LAYOUT -Soldering side-

(SCALE 4:1)

REVISIONS				
P.	LTN.	DESCRIPTION	DATE	APPV.
-	-	SEE SHEET 1	-	-

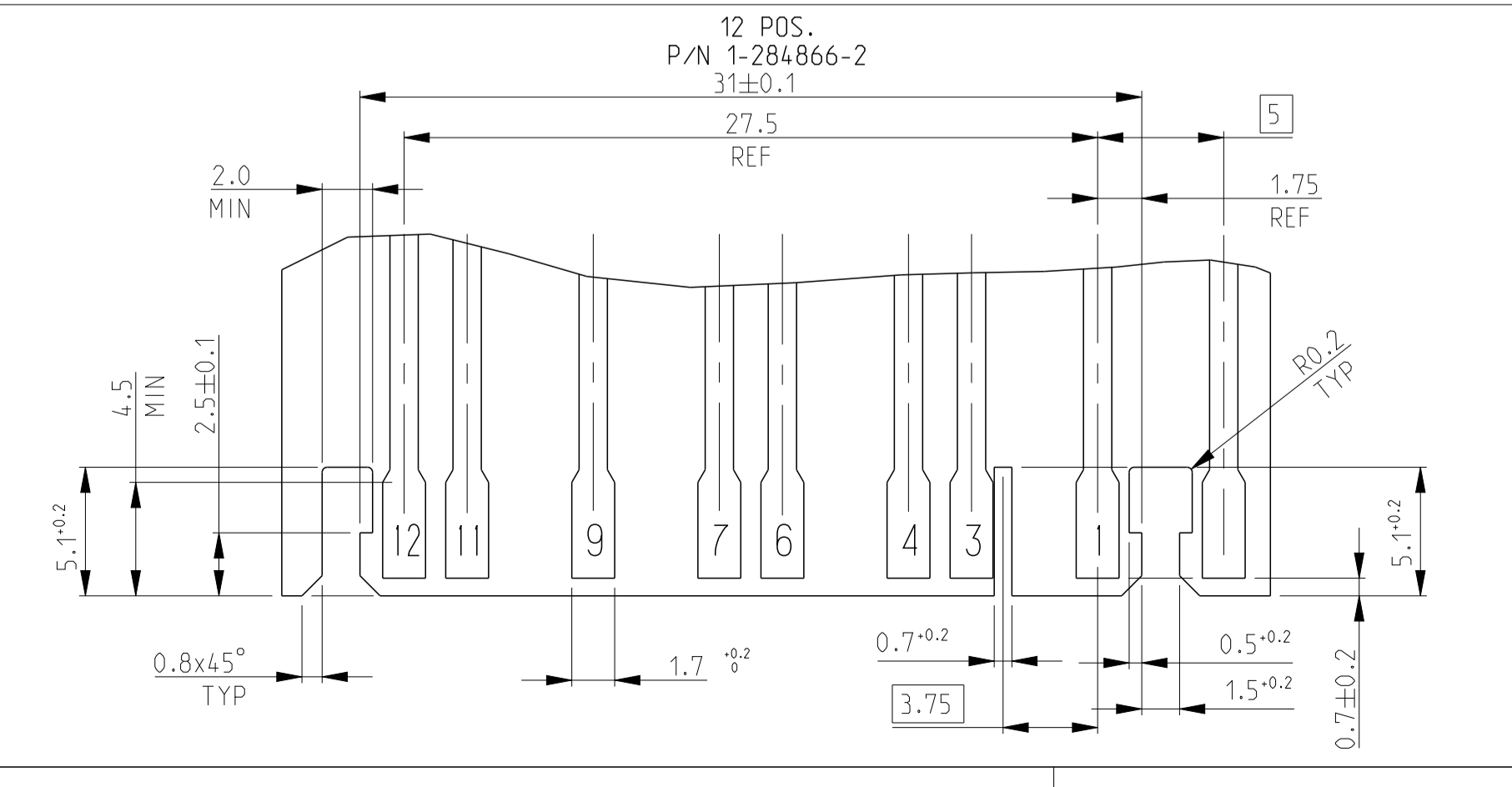
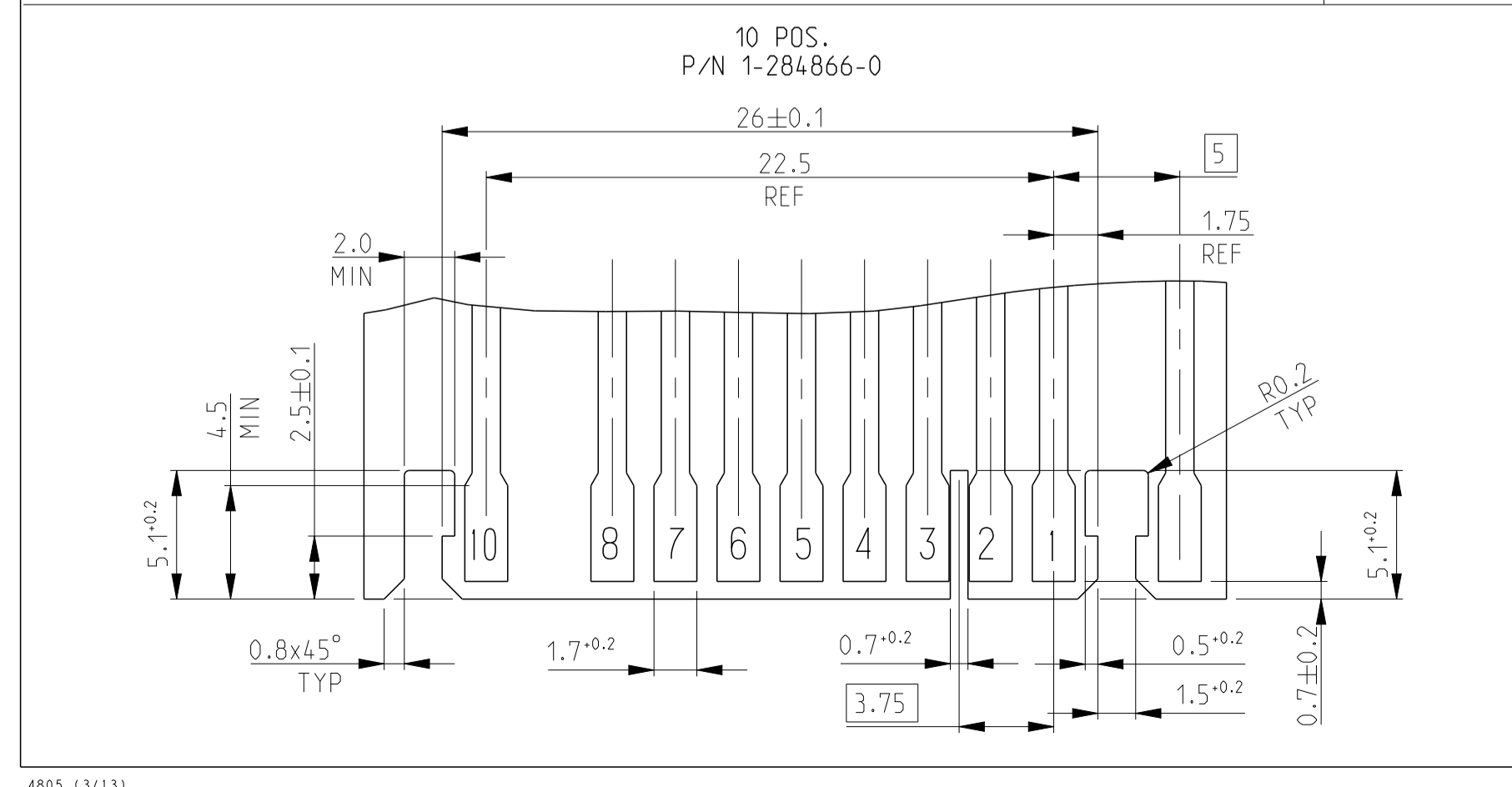
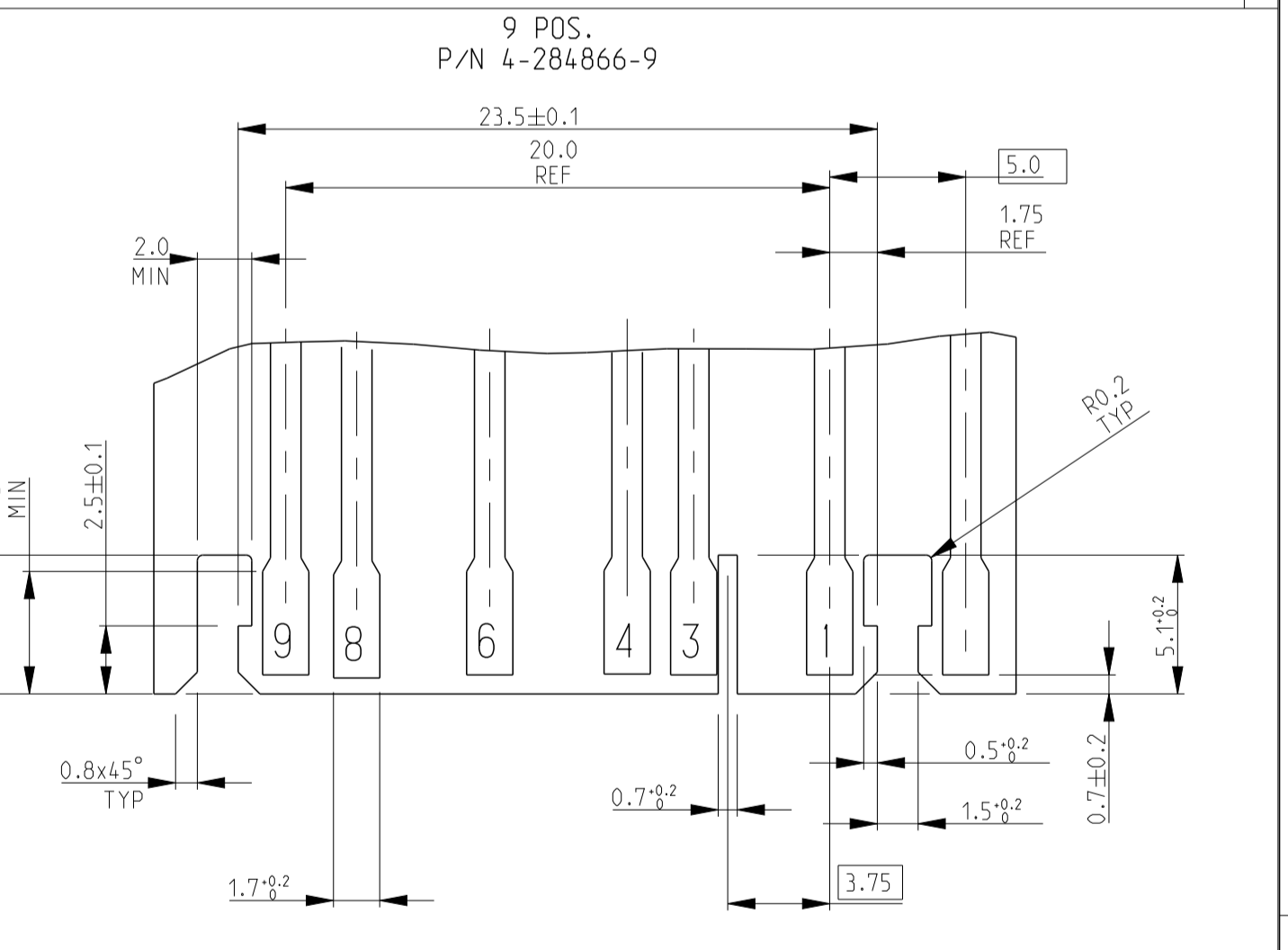
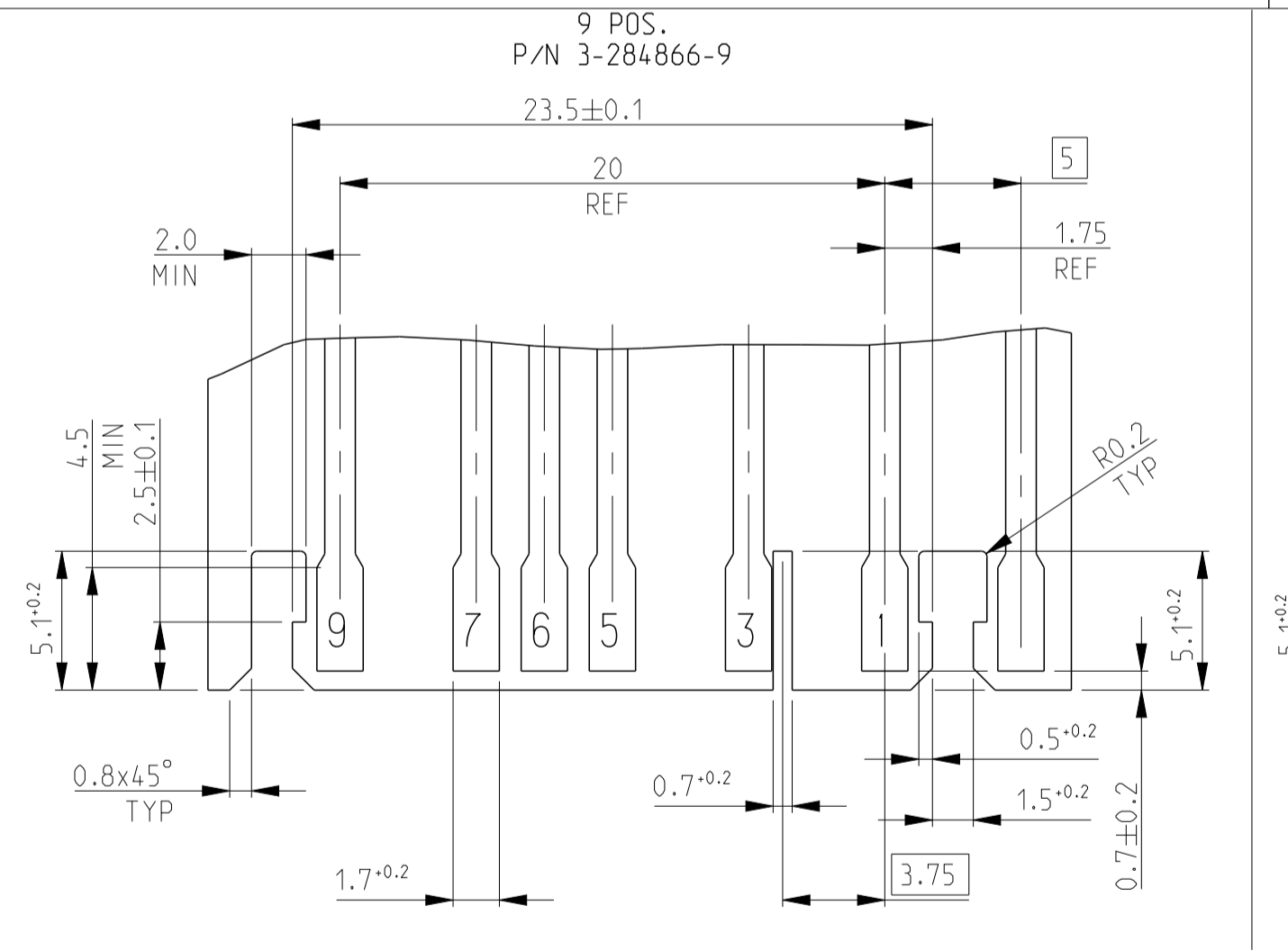
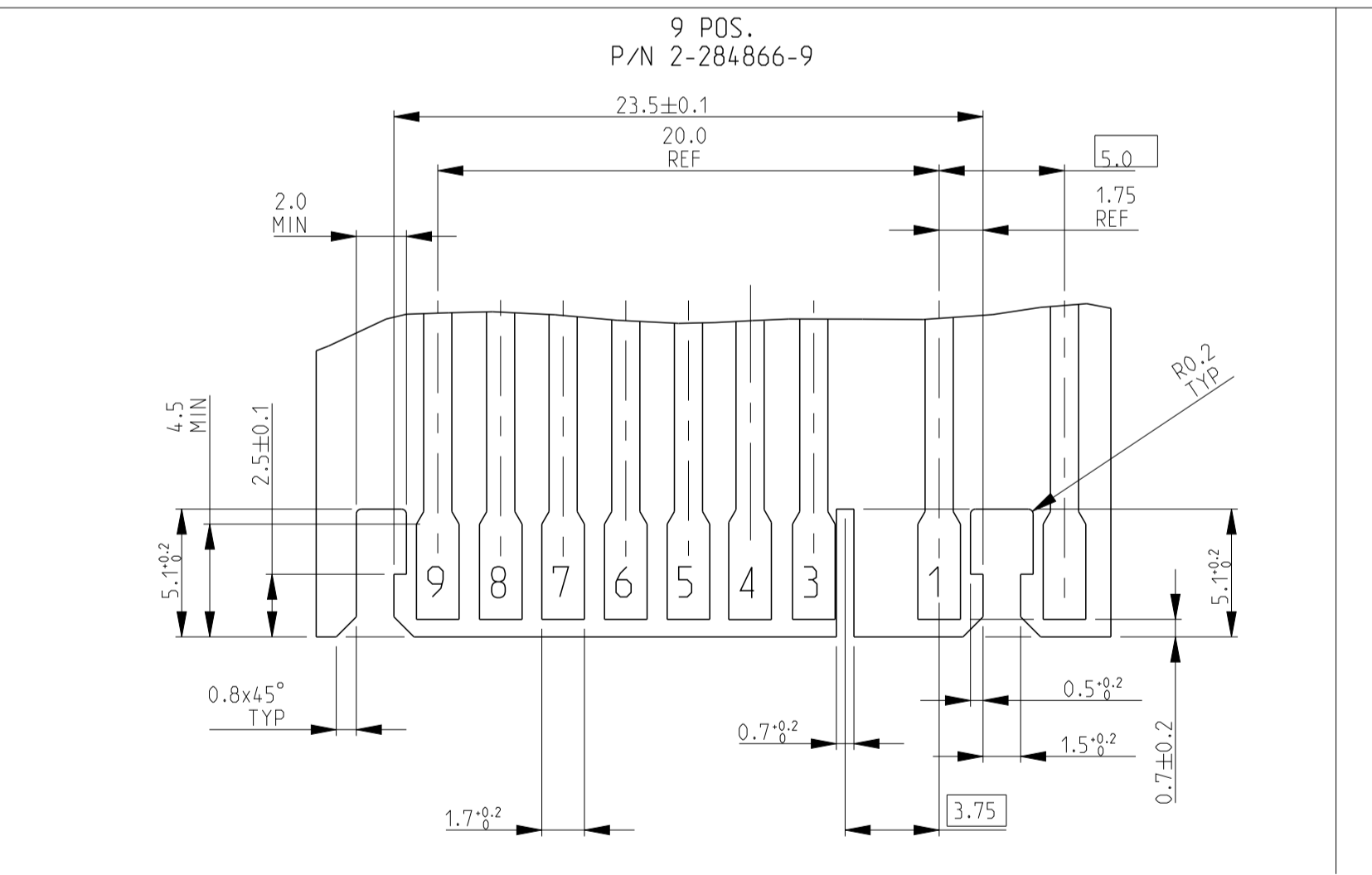
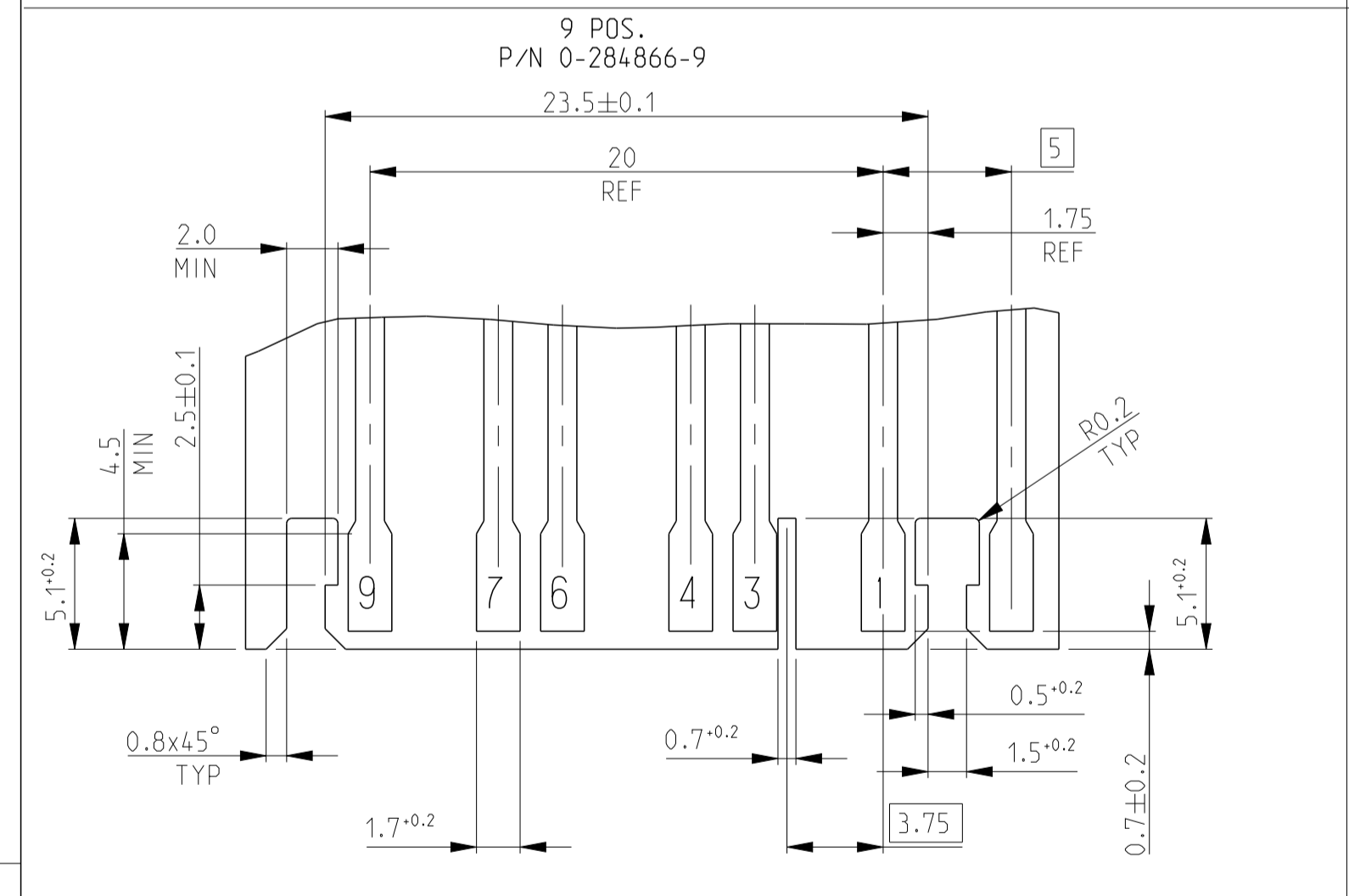
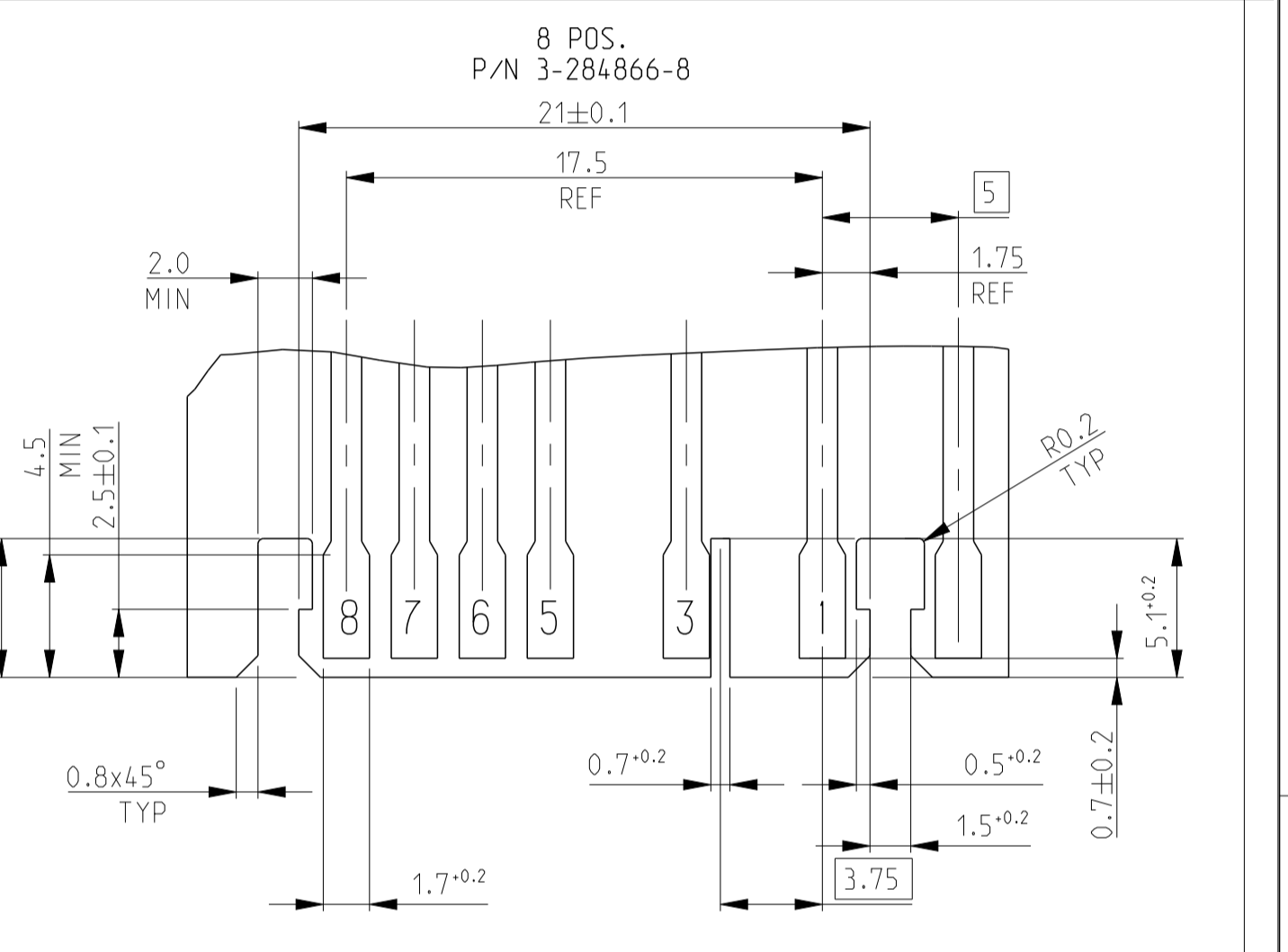
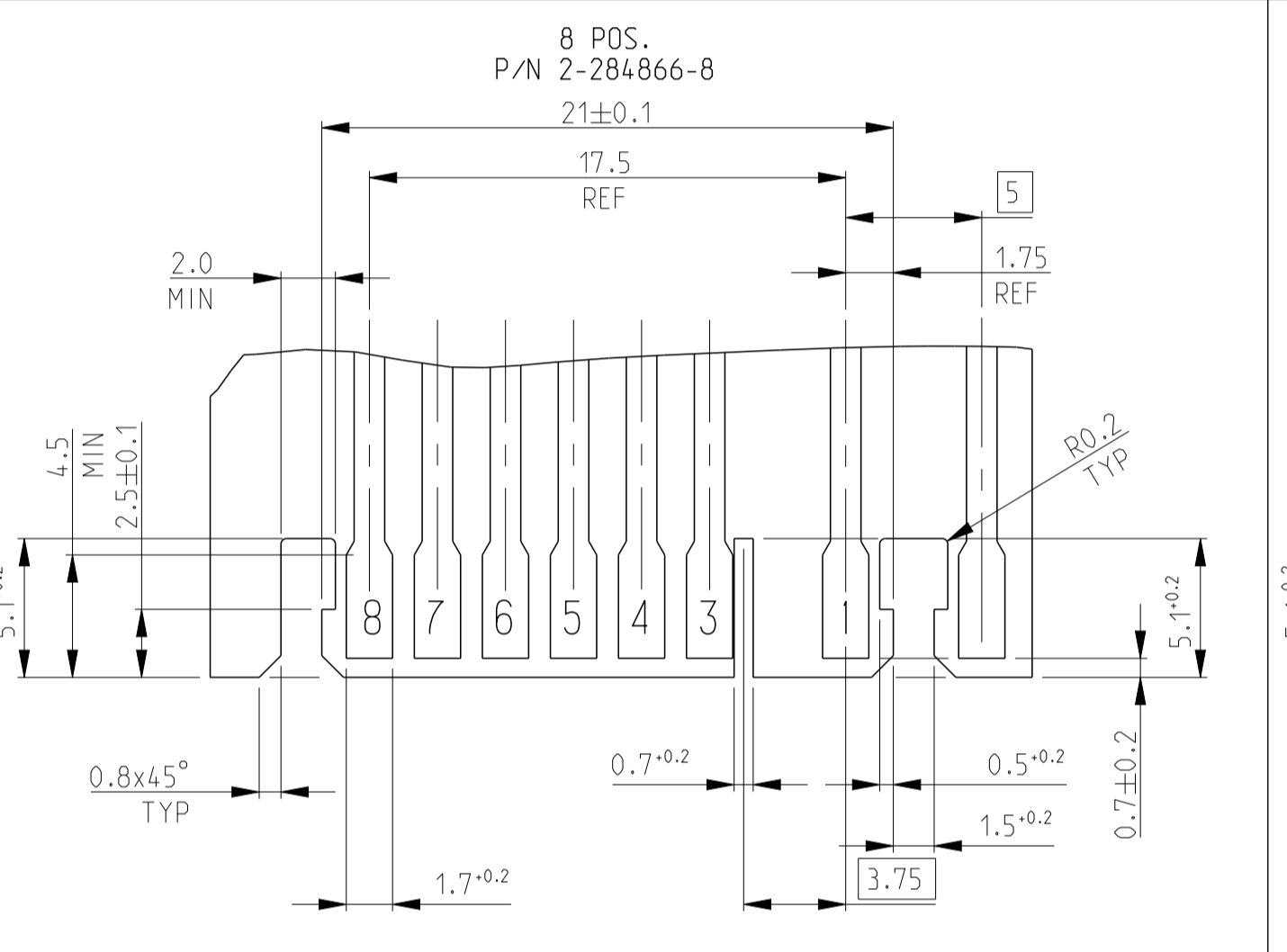
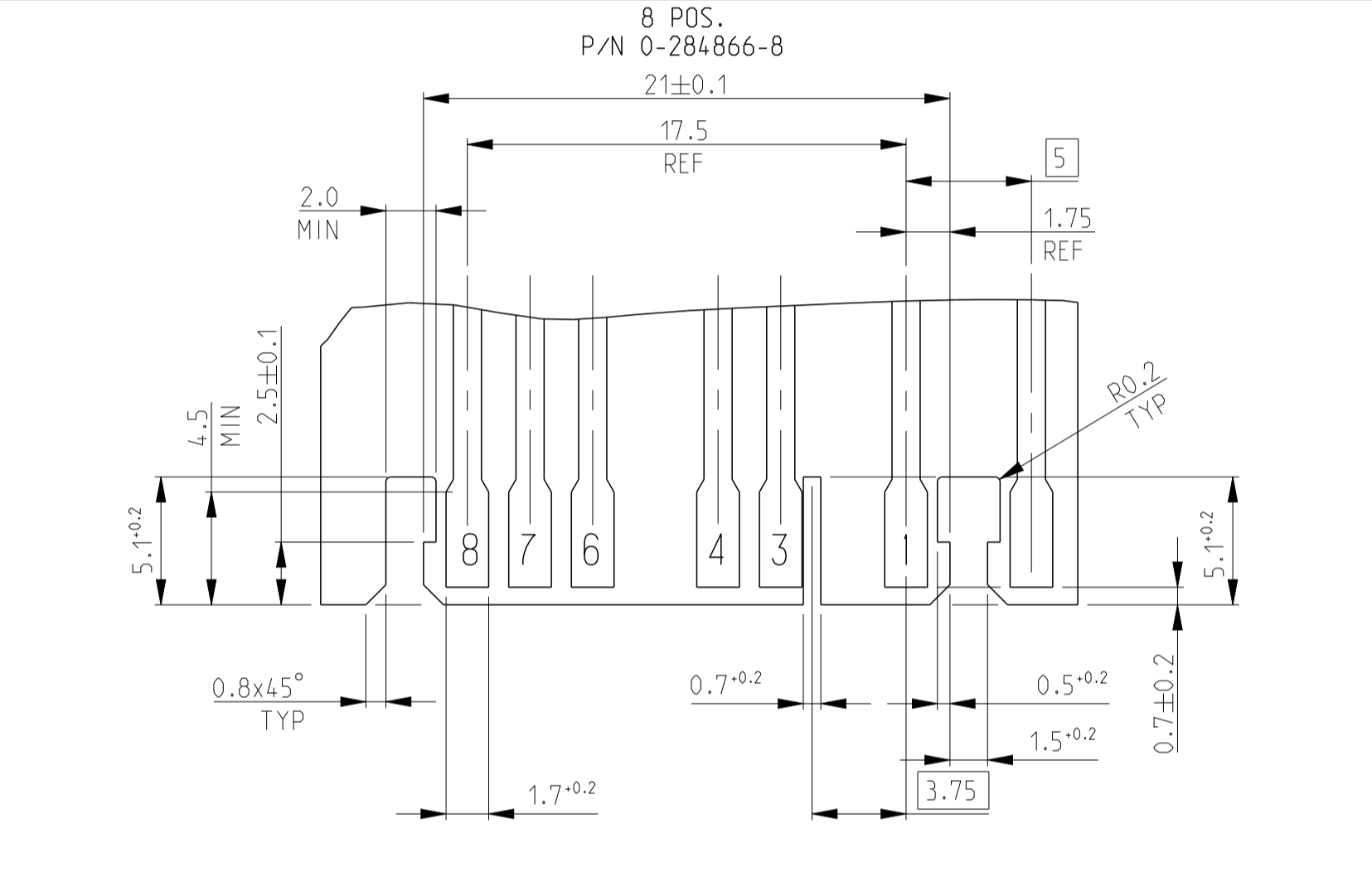
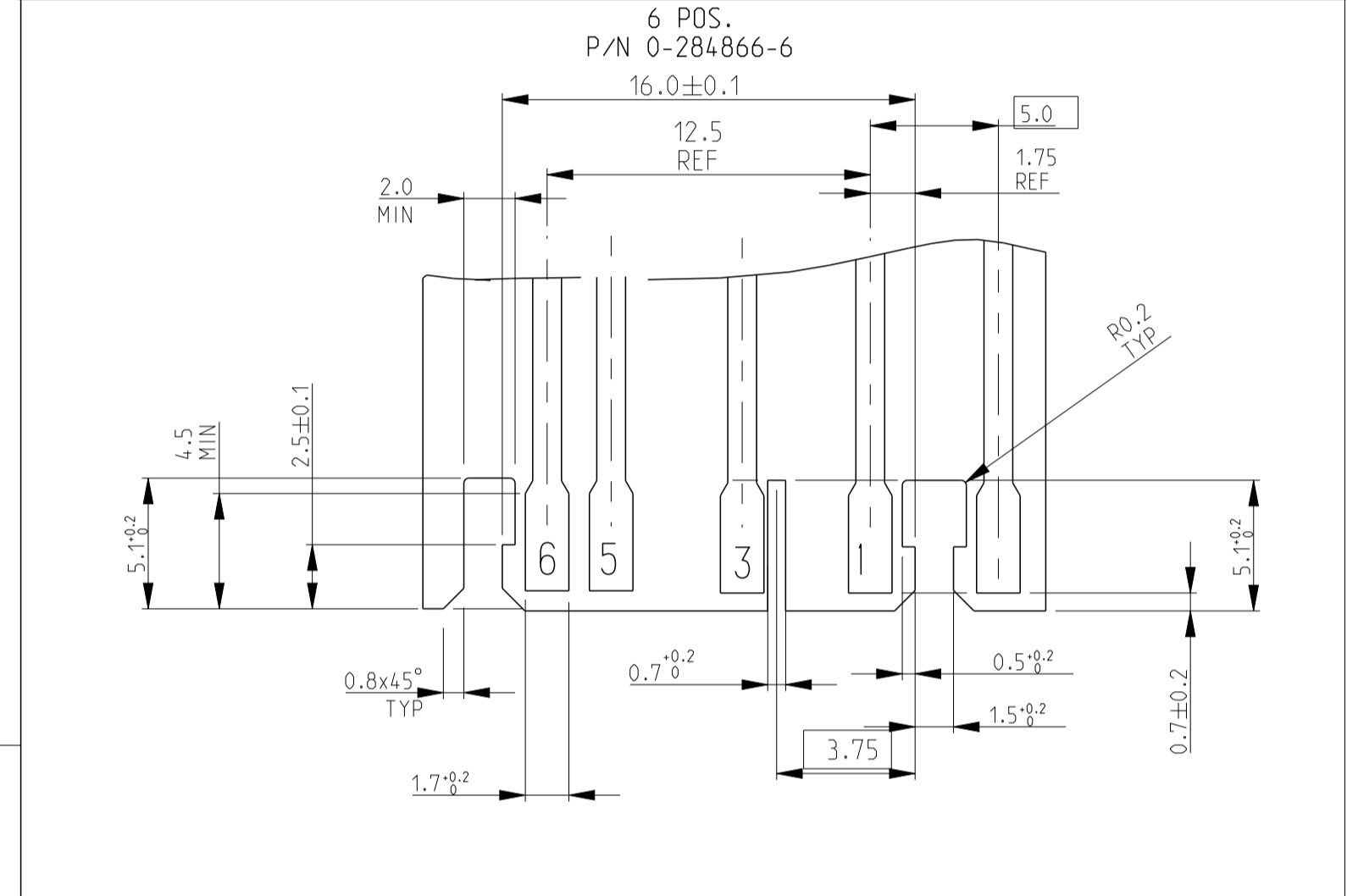
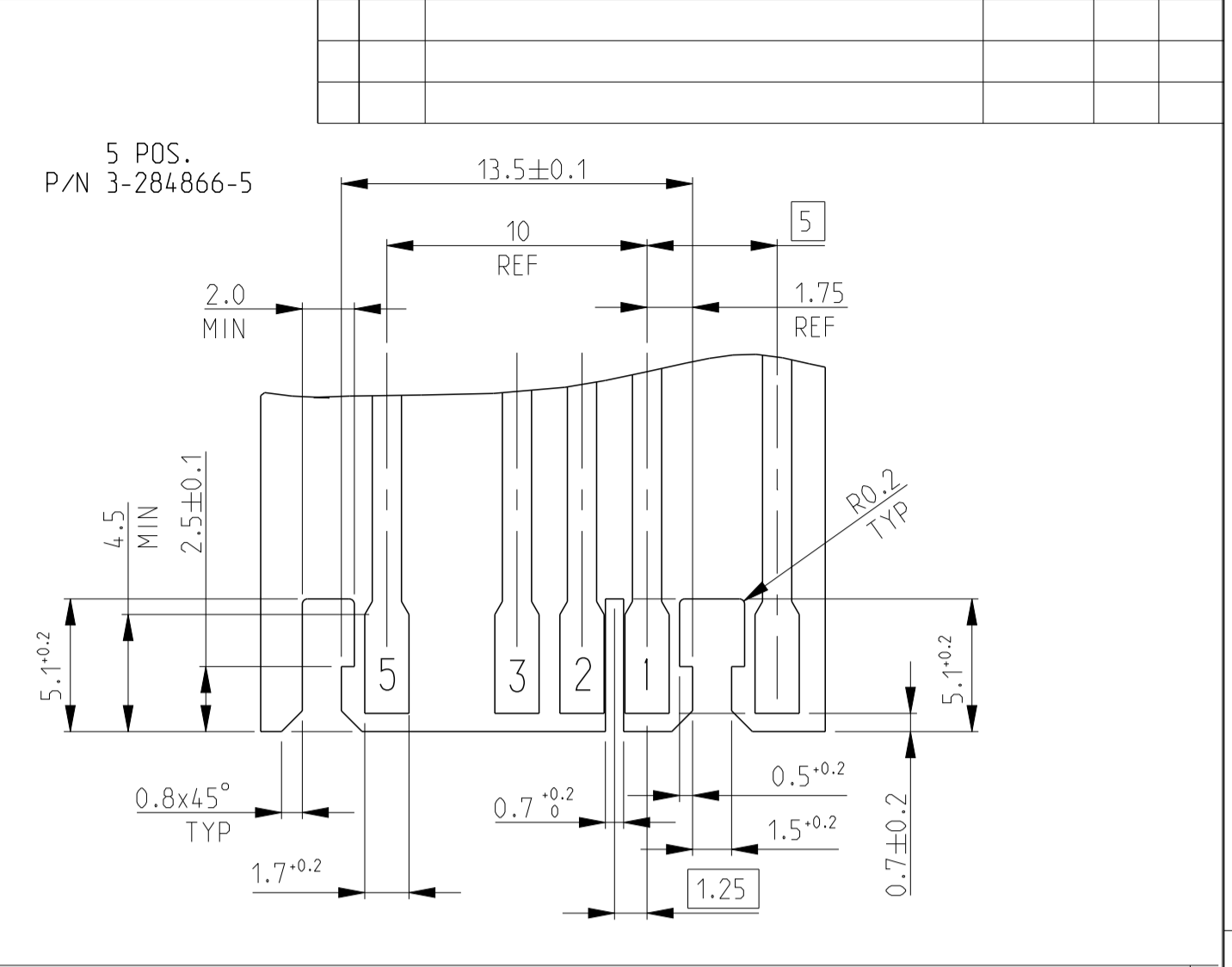
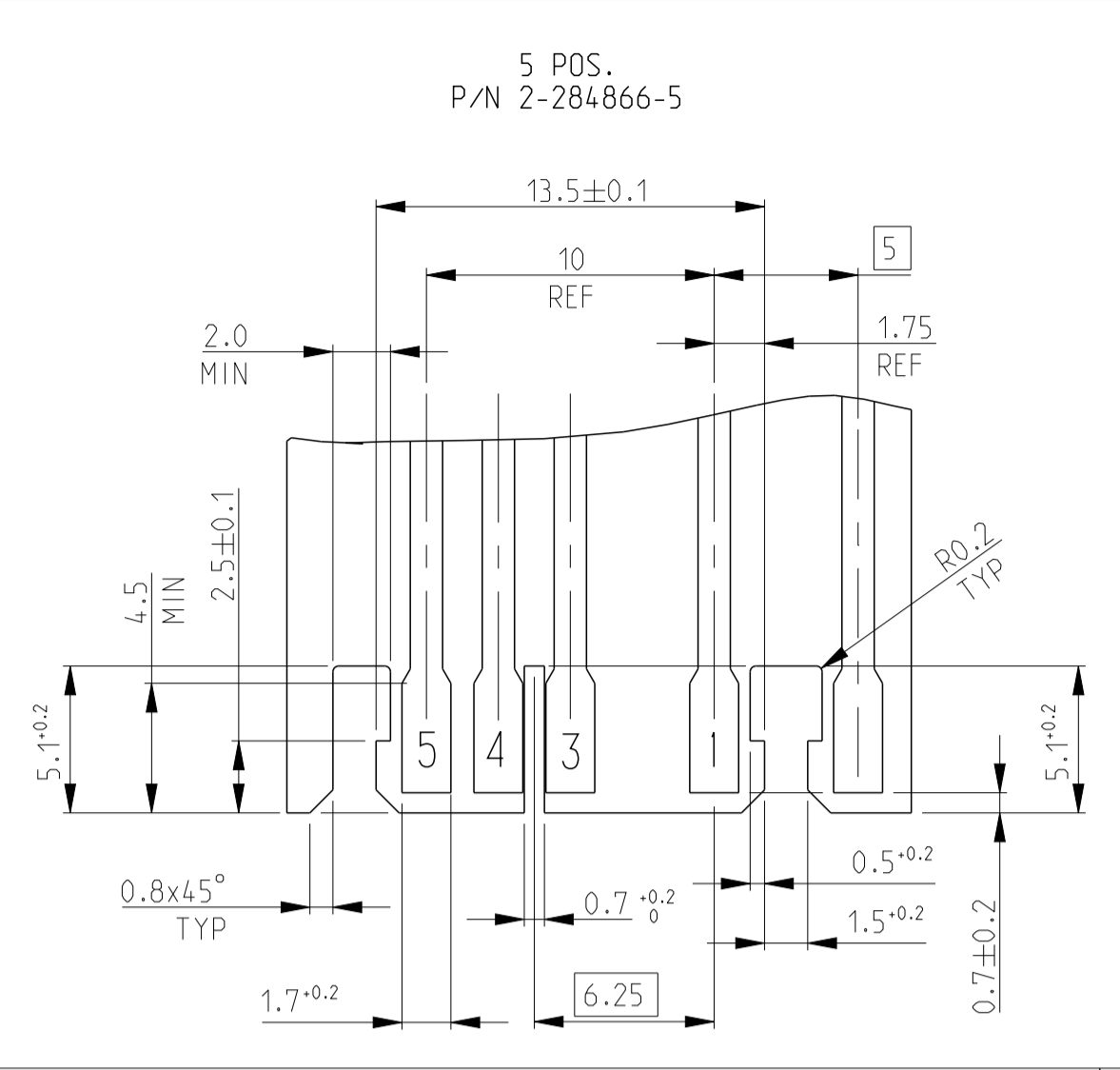
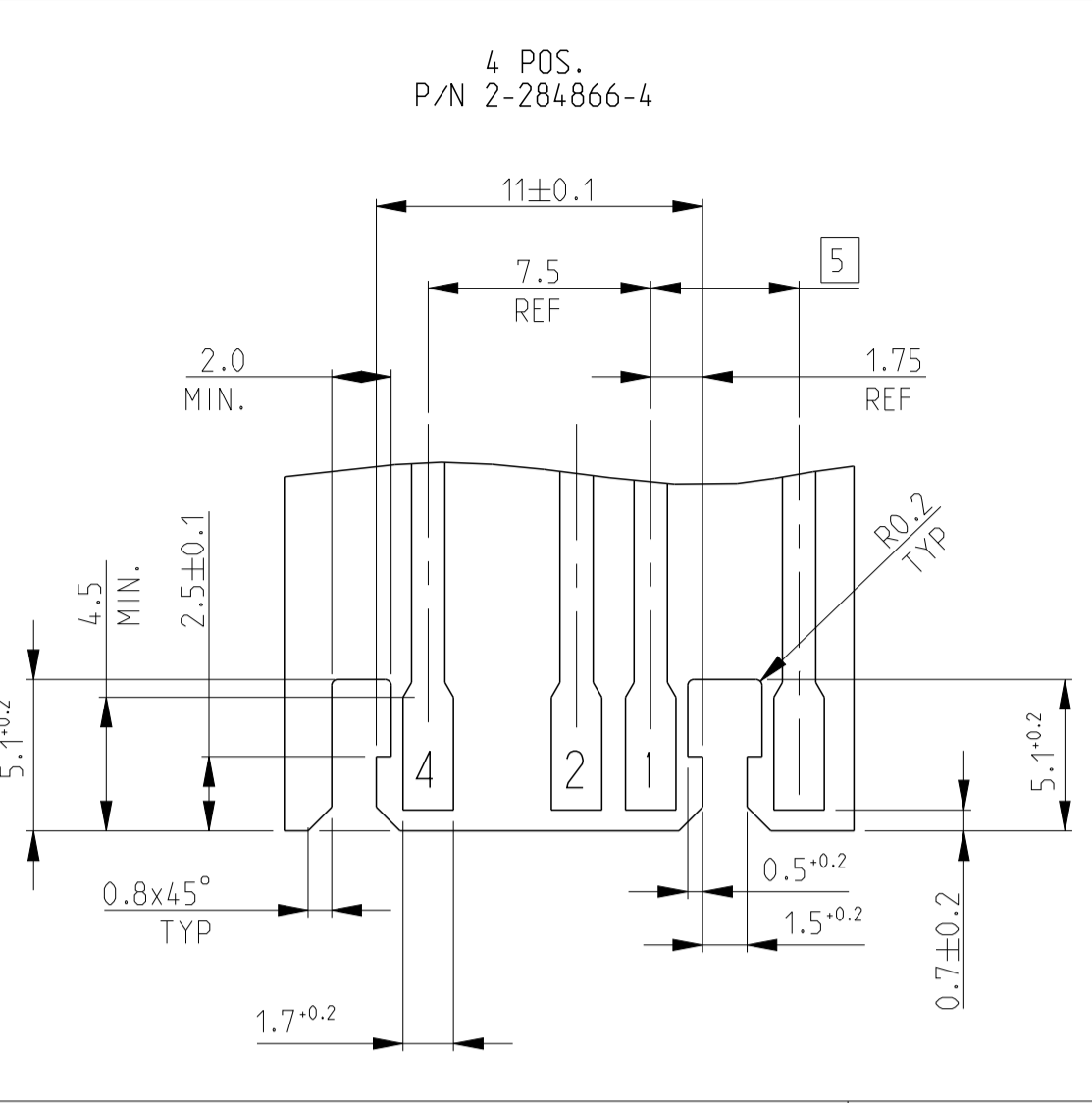
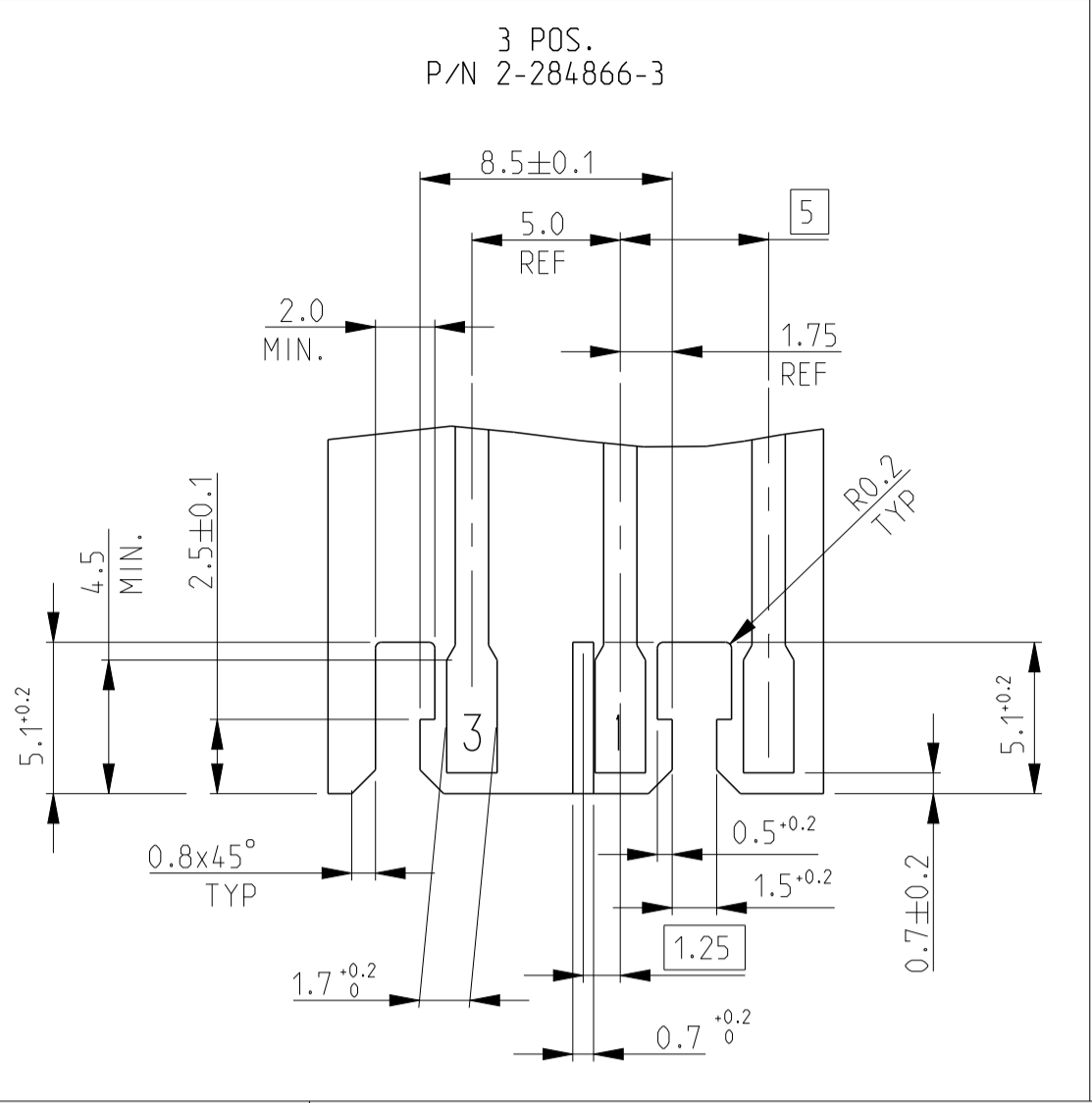
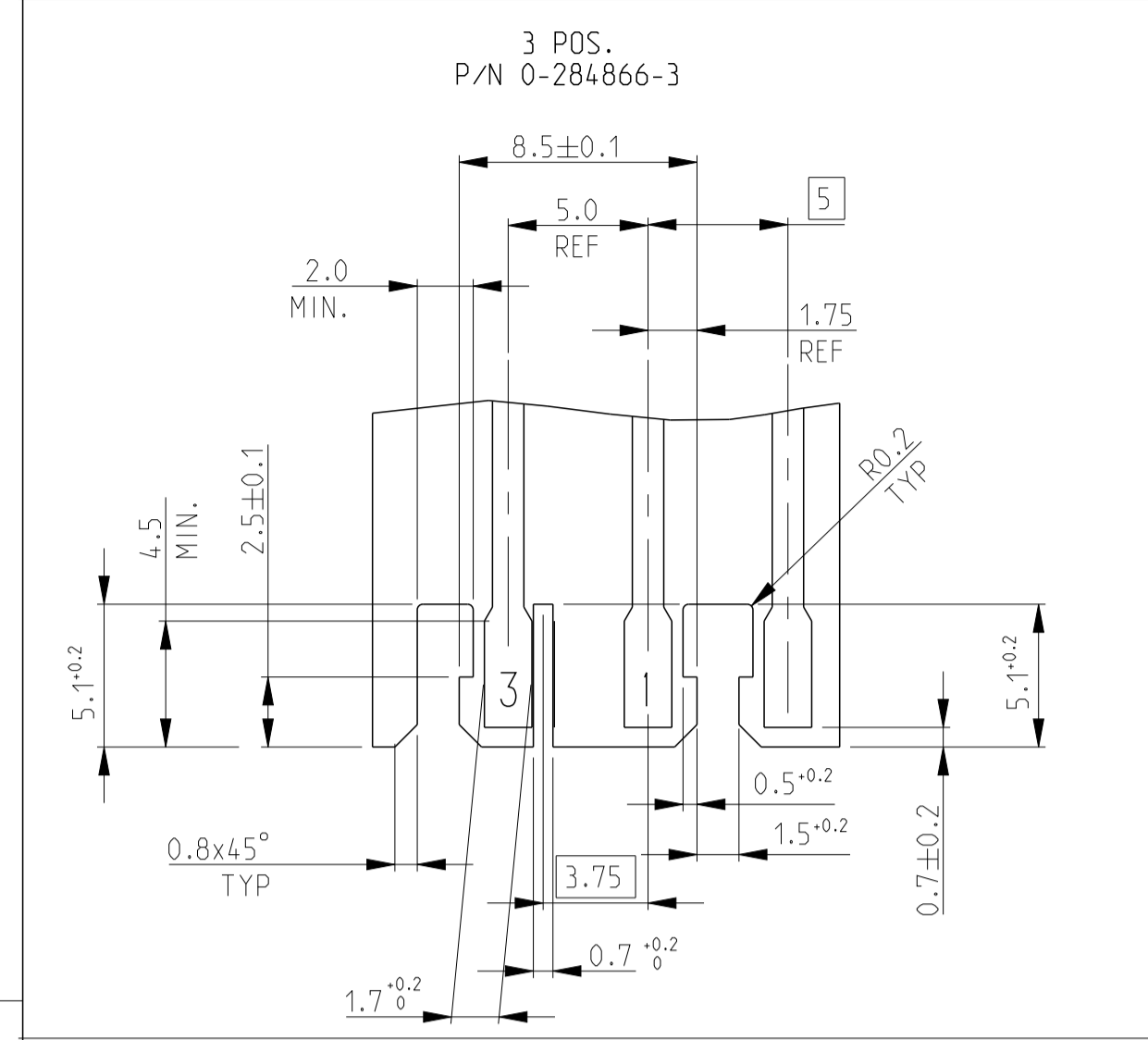

THIS DRAWING IS A CONTROLLED DOCUMENT.		OWN: R. FABRIS	03JUL2002
DIMENSIONS: mm		CHK: -	
TOLERANCES UNLESS OTHERWISE SPECIFIED:		APVD: -	
0 PLC		PRODUCT SPEC	
1 PLC		108-20238	
2 PLC		APPLICATION SPEC	
3 PLC		116-18049-1	
4 PLC		WEIGHT	
ANGLES		FINISH	
MATERIAL: SEE TABLE		SEE TABLE	
CUSTOMER DRAWING		SCALE: 6:1	SHEET 2 OF 4

**STE** TE Connectivity

NAME: DUOPLUG 2.5 FEMALE CONN., SIDE LOCKING, KEYED (SELECTIVELY LOADED CONTACTS)

SIZE: A1 00779 ©=284866

RESTRICTED TO: -

REVISIONS				
P.	LTN.	DESCRIPTION	DATE	APPV.
-	-	SEE SHEET 1	-	-

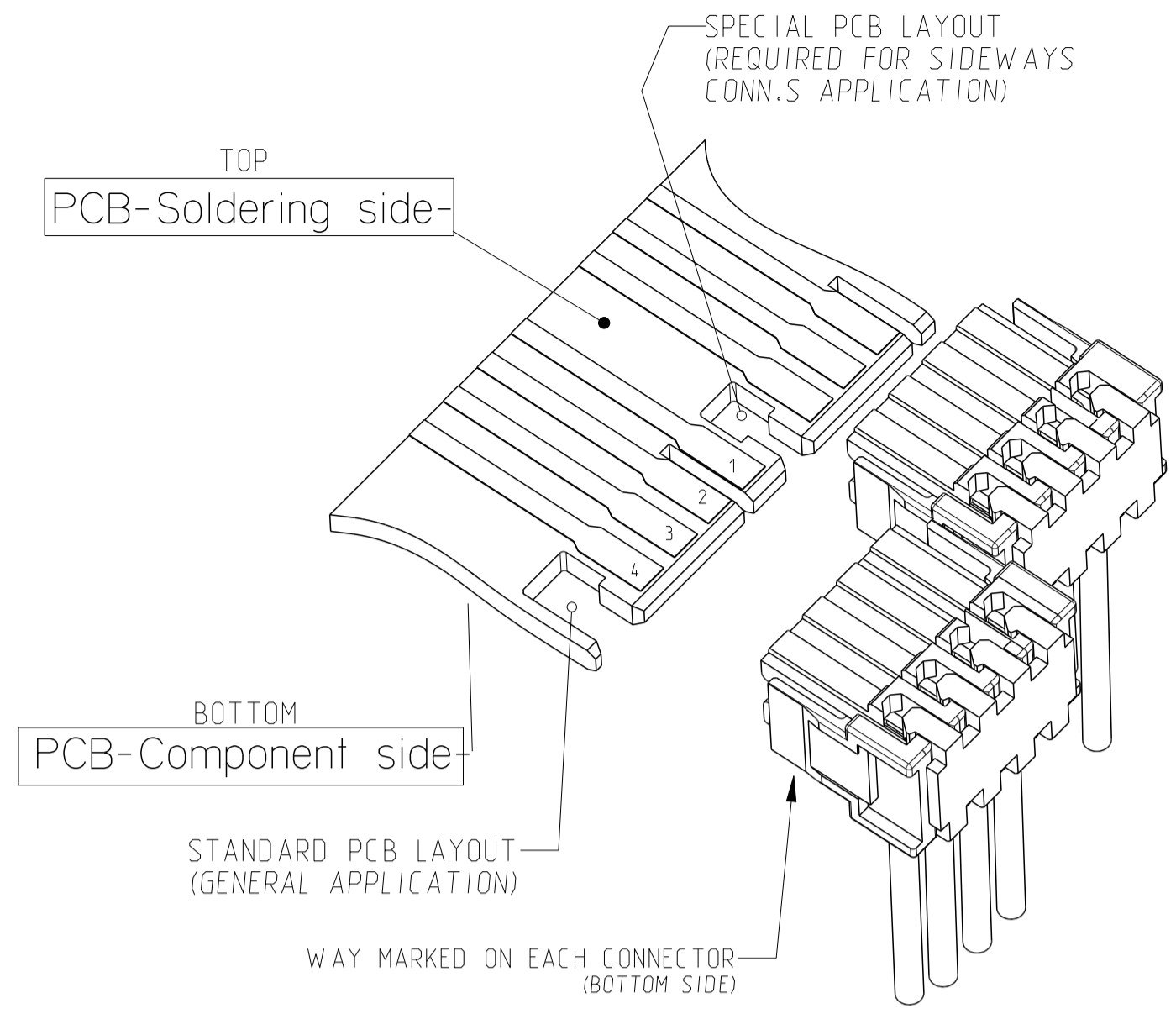
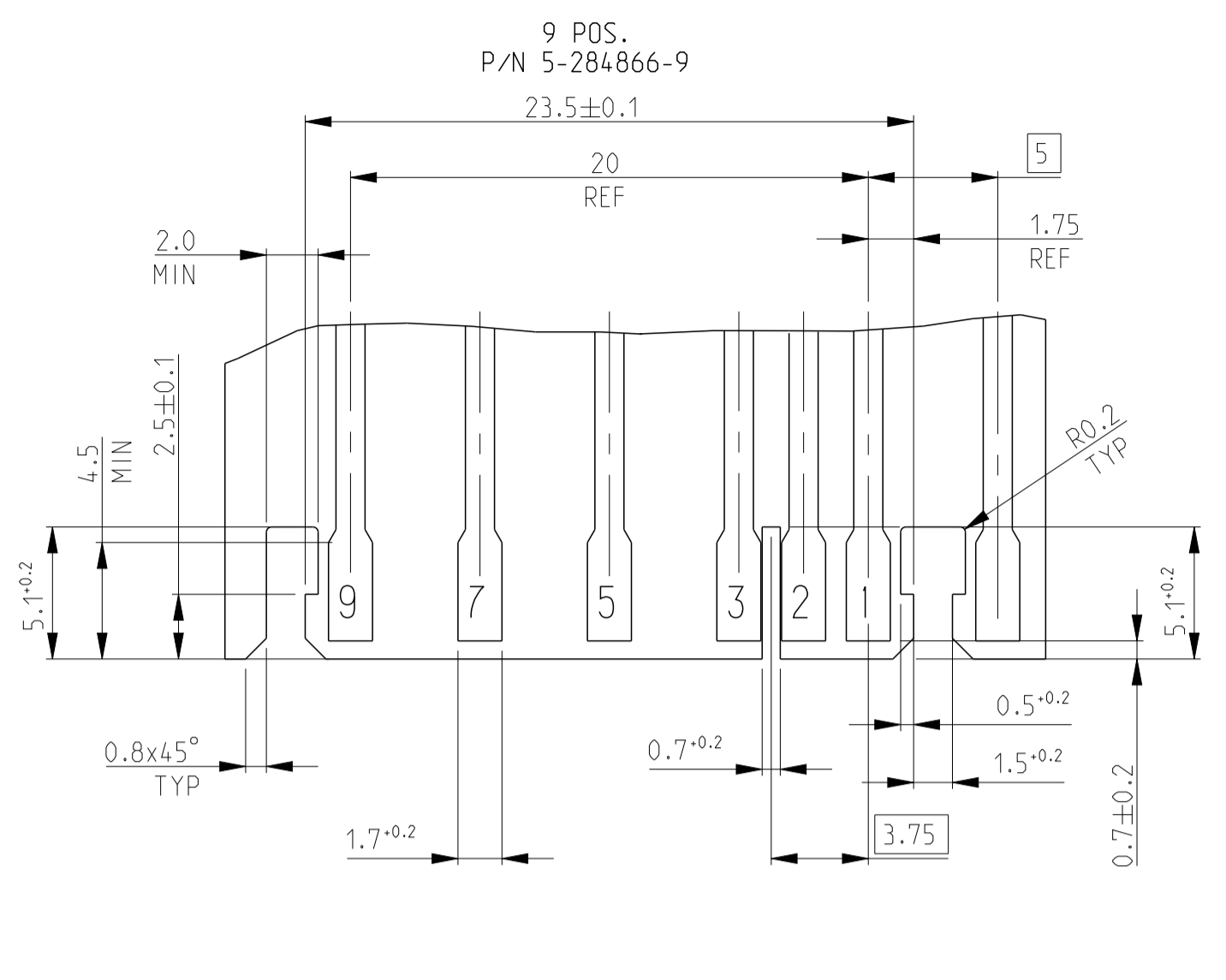
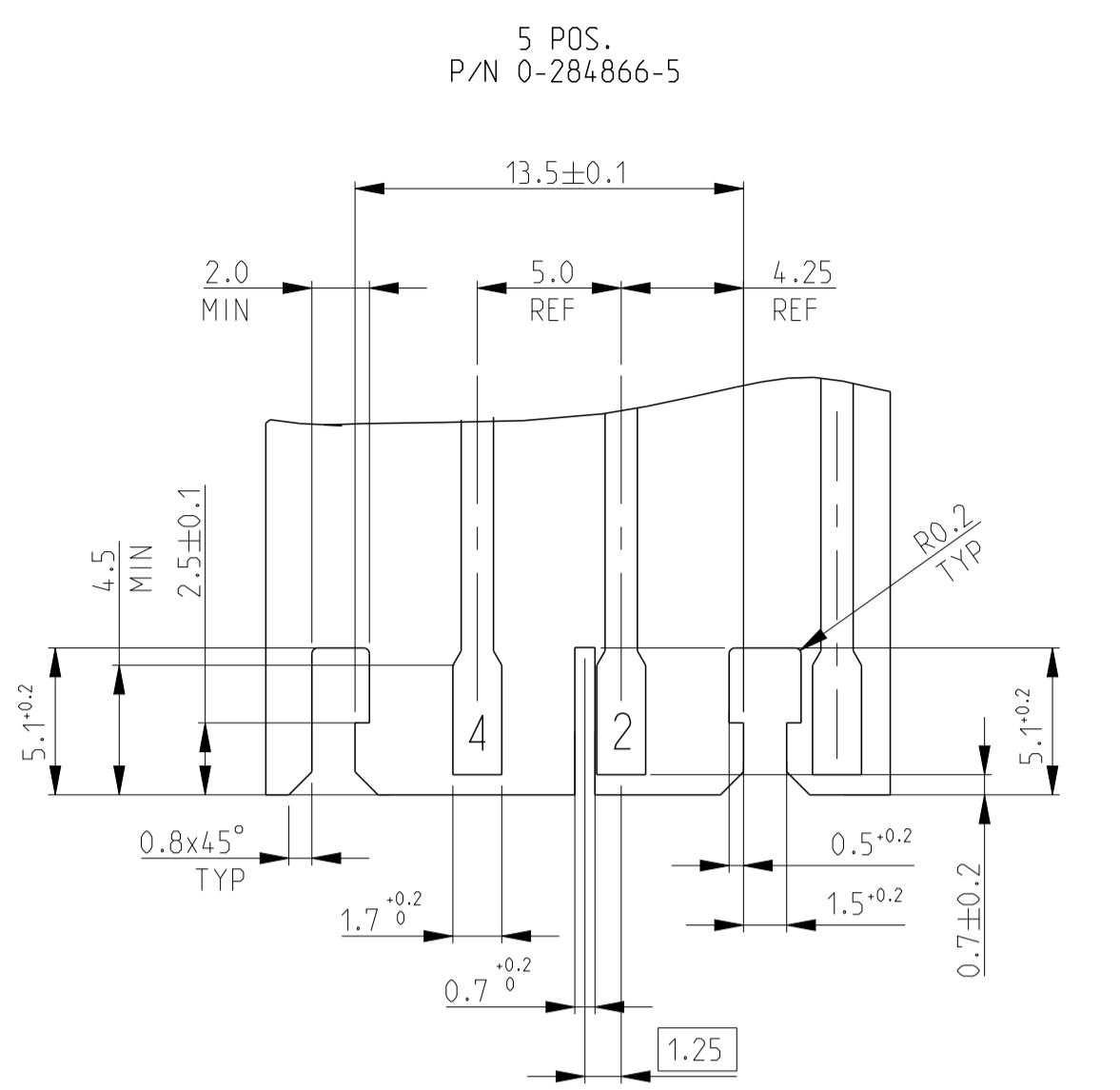

CONNECTION LAYOUT  
 E.G P/N 0-284865-4  
 (SCALE 4:1)

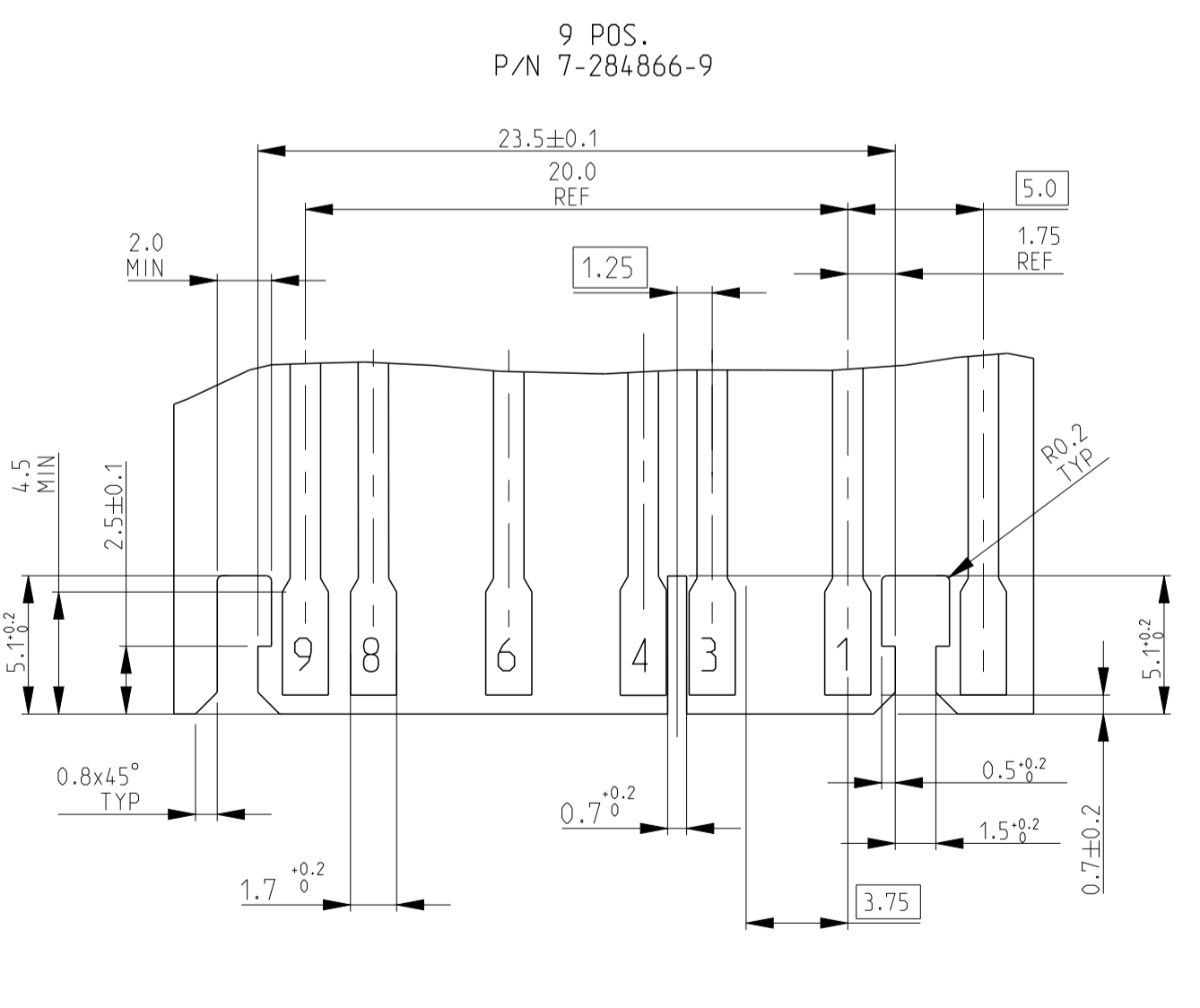
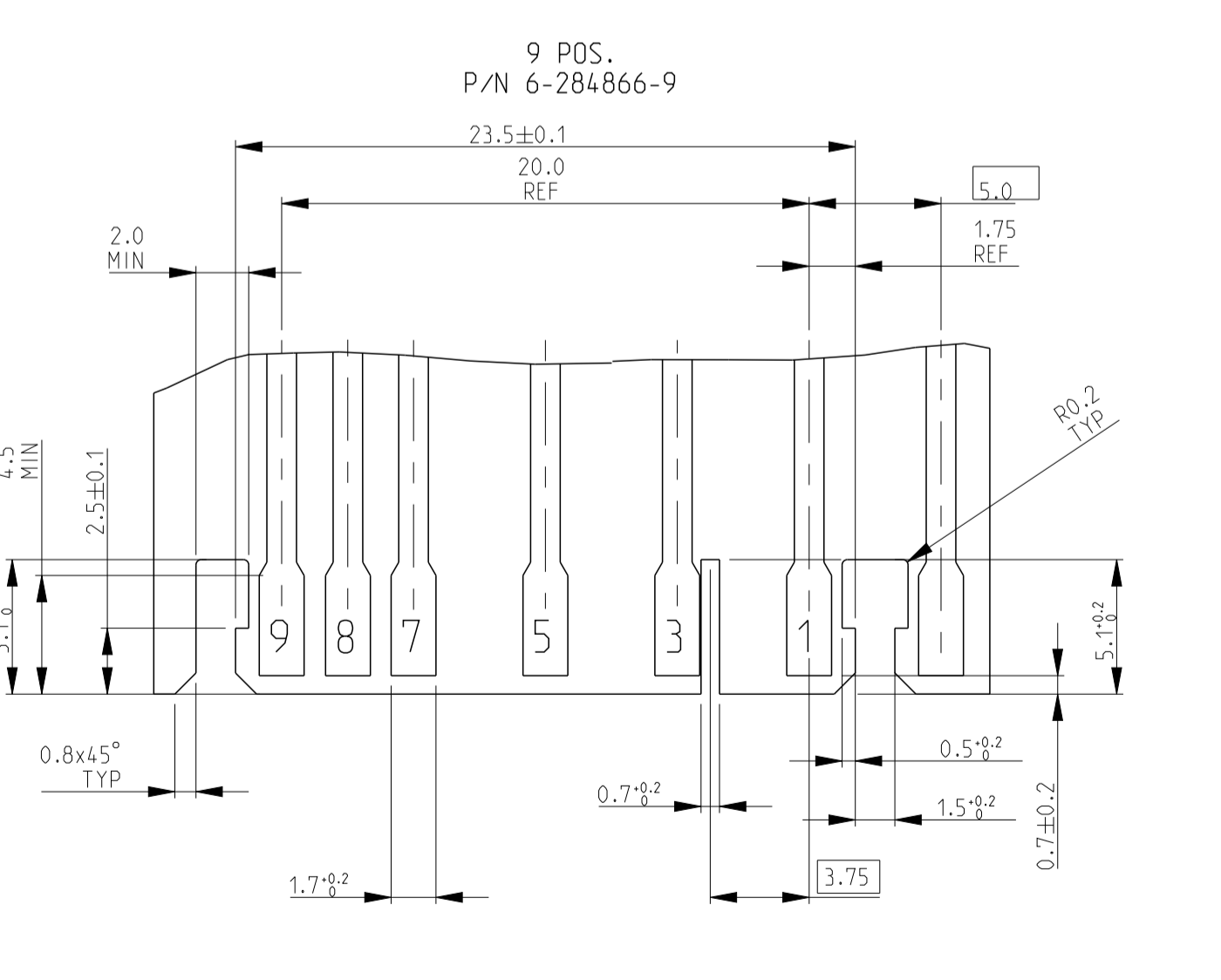
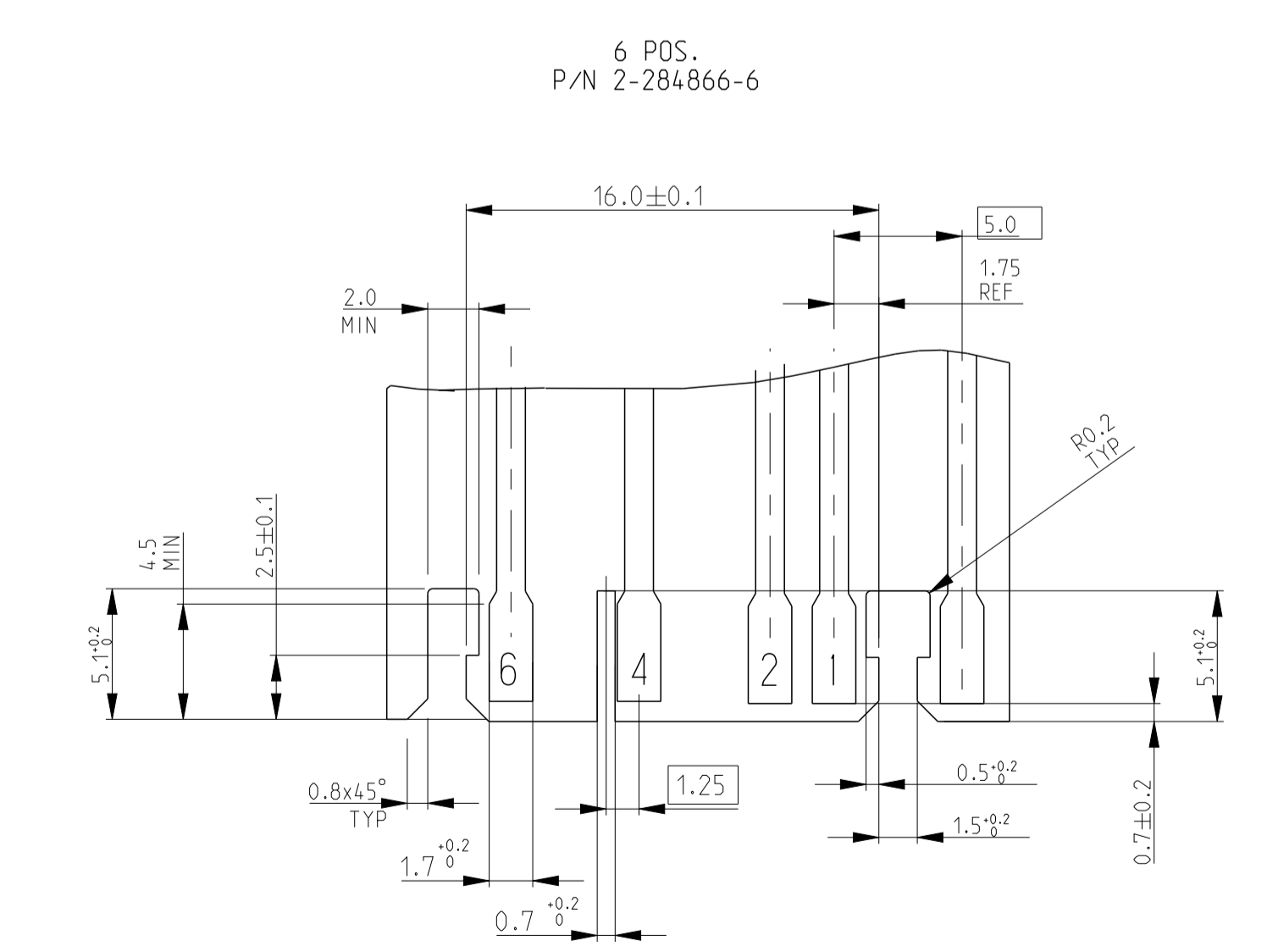
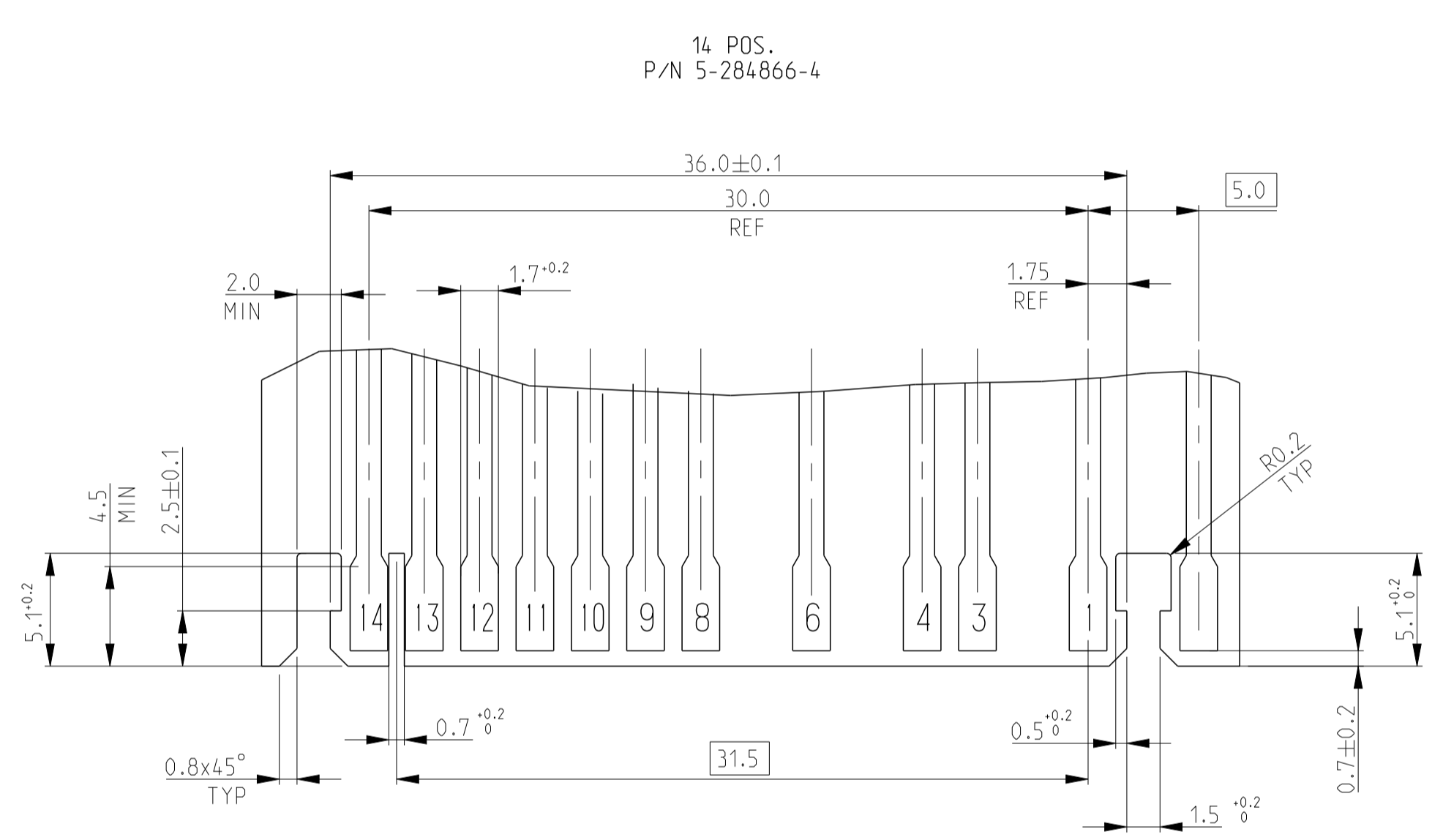
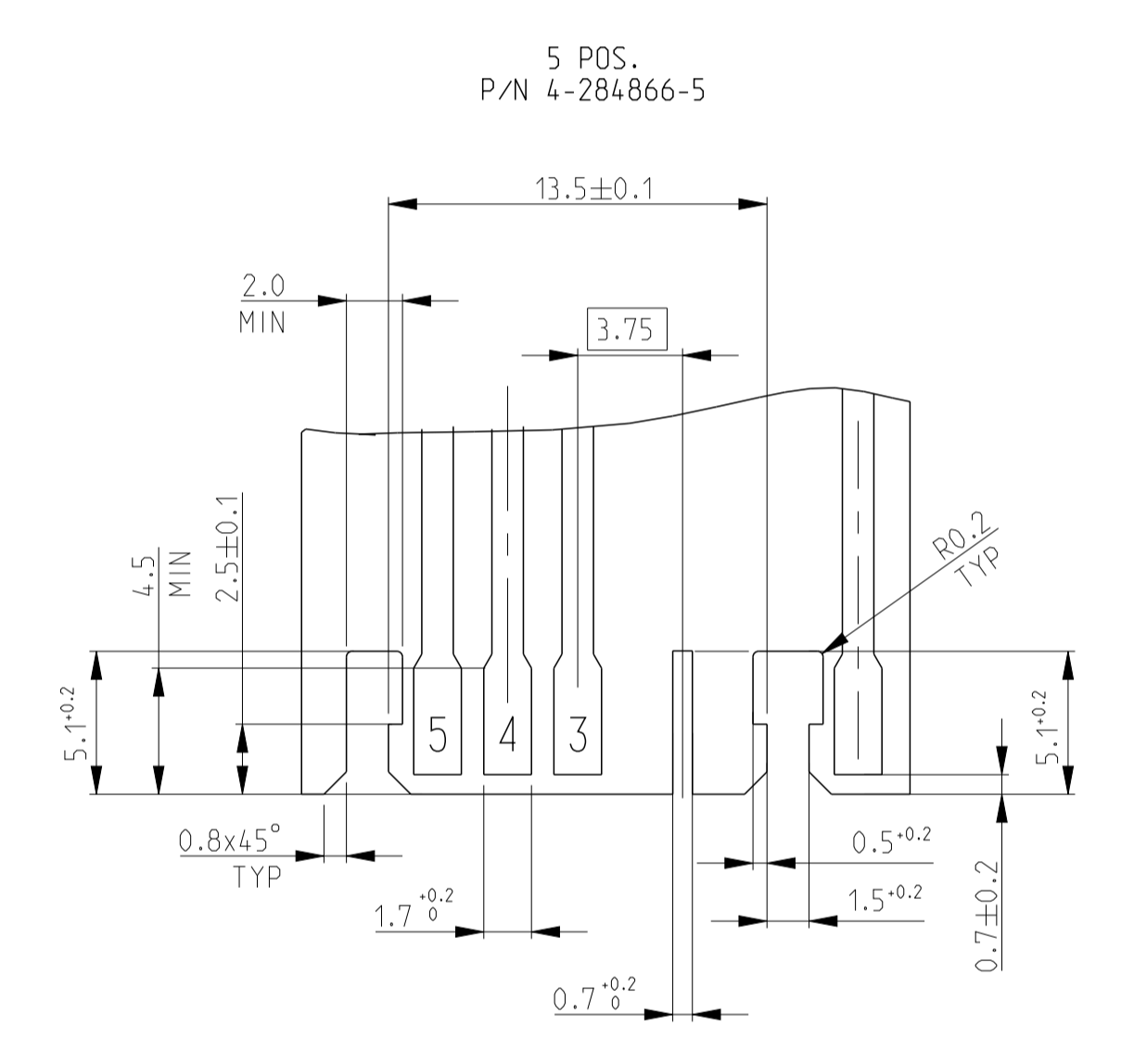
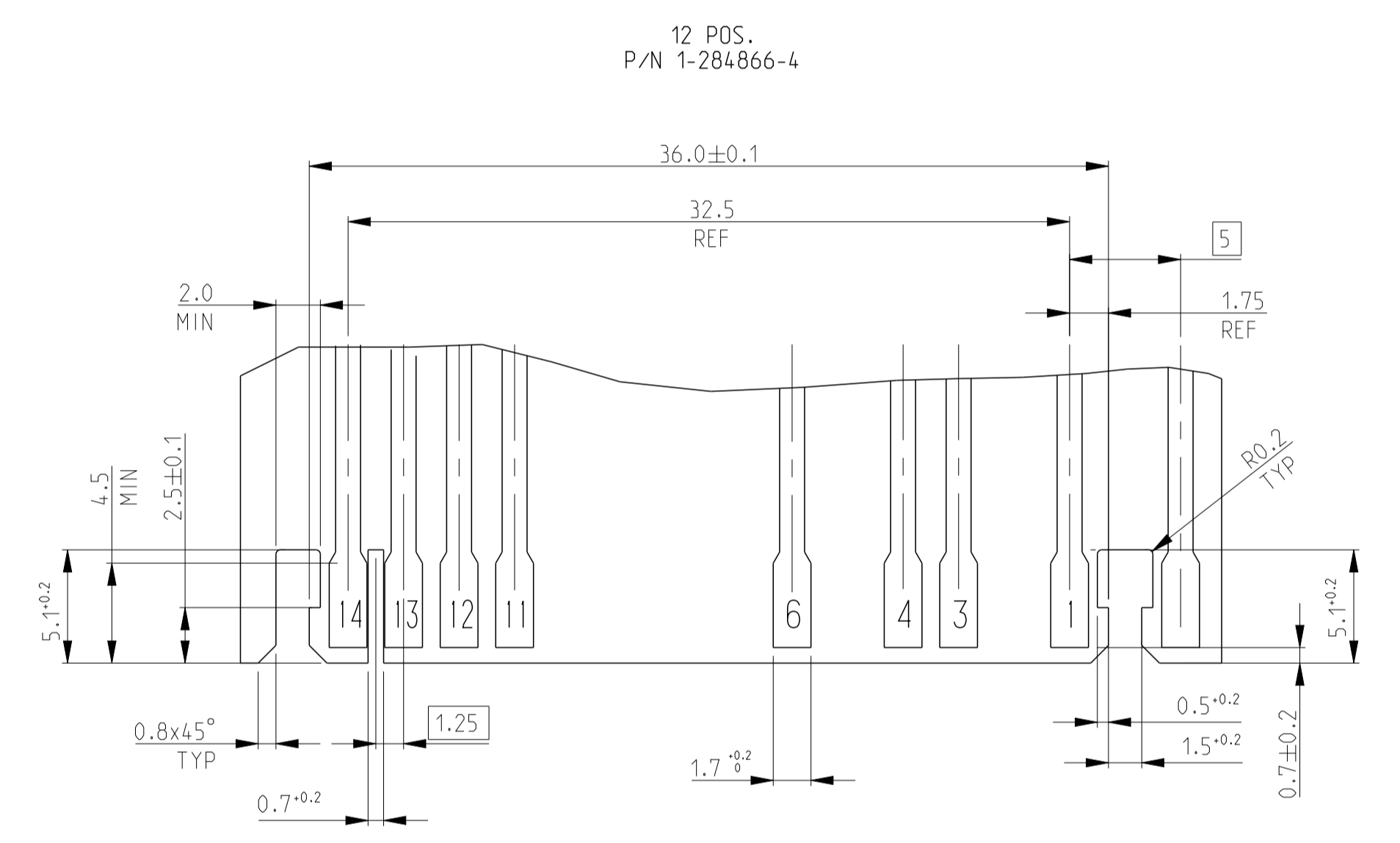

THIS DRAWING IS A CONTROLLED DOCUMENT.		OWN: R. FABRIS	03JUL2002	TE Connectivity	
DIMENSIONS: mm		CHK: -	APV: -		
TOLERANCES UNLESS OTHERWISE SPECIFIED:		PRODUCT SPEC: 108-20238 APPLICATION SPEC: 116-18049-1		NAME: DUOPLUG 2.5 FEMALE CONN., SIDE LOCKING, KEYED (SELECTIVELY LOADED CONTACTS) SIZE: 116-18049-1 WEIGHT: - CUSTOMER DRAWING	
MATERIAL: SEE TABLE		FINISH: SEE TABLE		RESTRICTED TO: A1 00779 ©=284866 SCALE: 6:1 SHEET 3 OF 4	

REVISIONS				
P.	LTN	DESCRIPTION	DATE	APPV
-	-	SEE SHEET 1	-	-

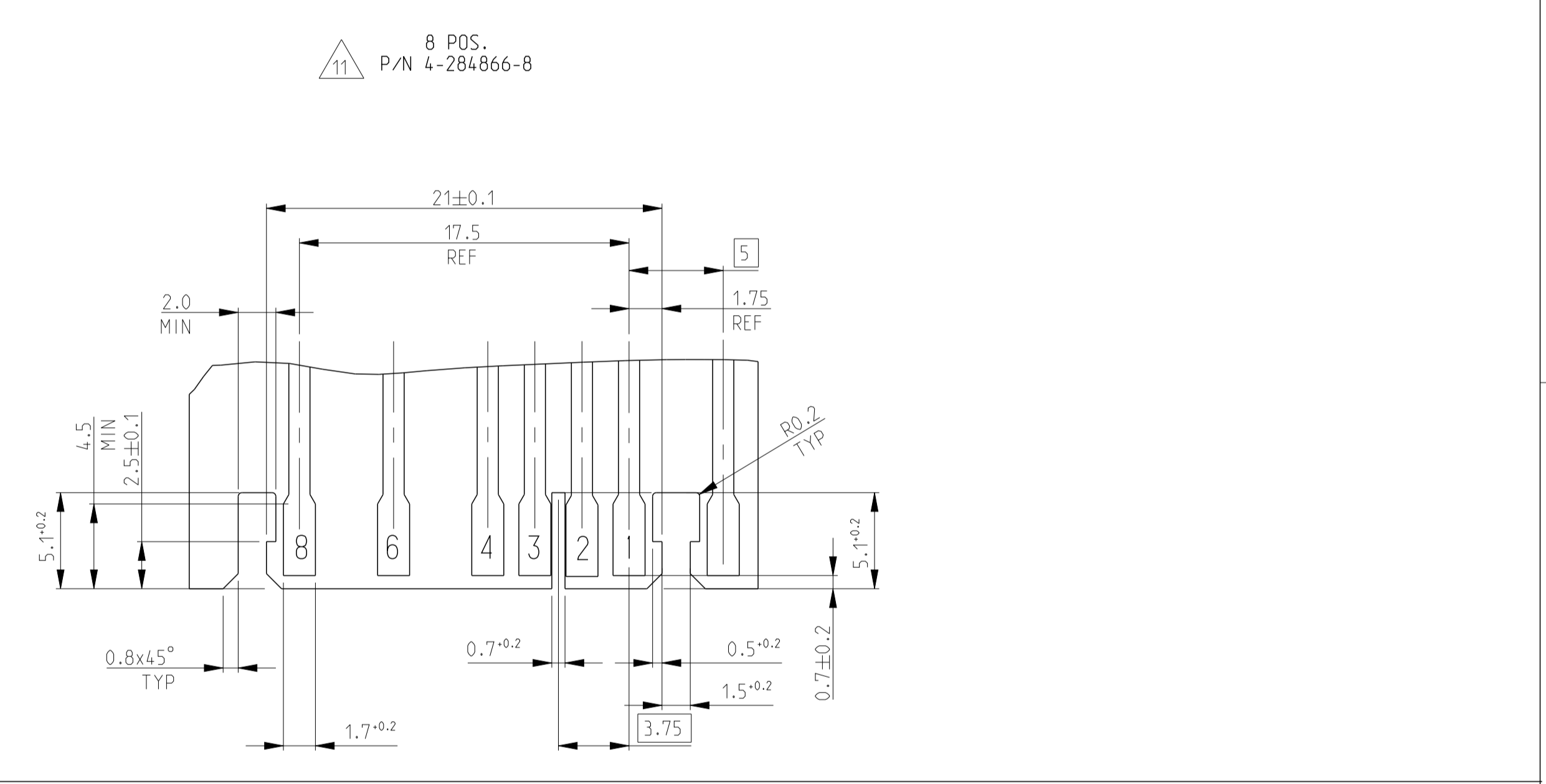
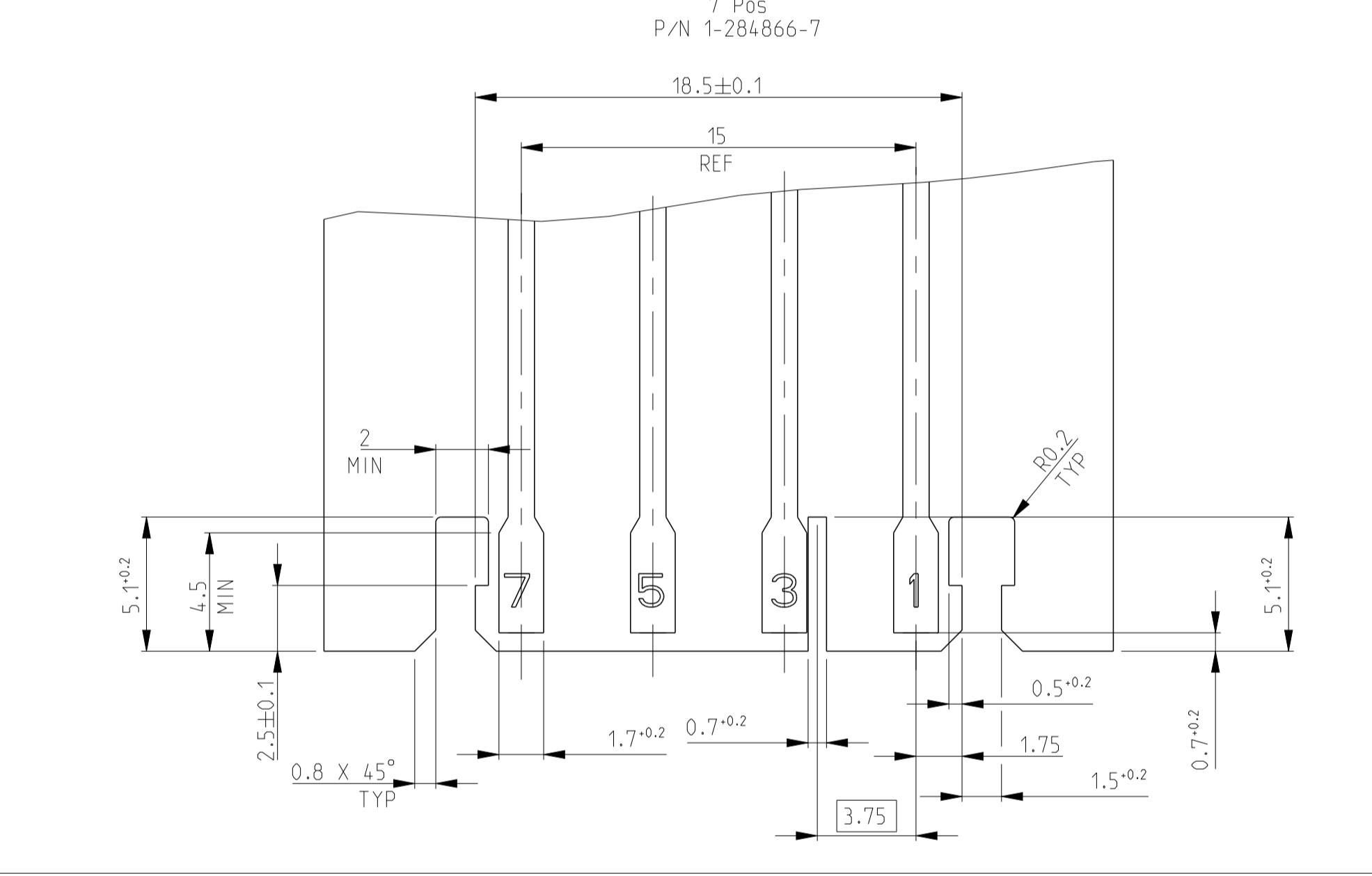
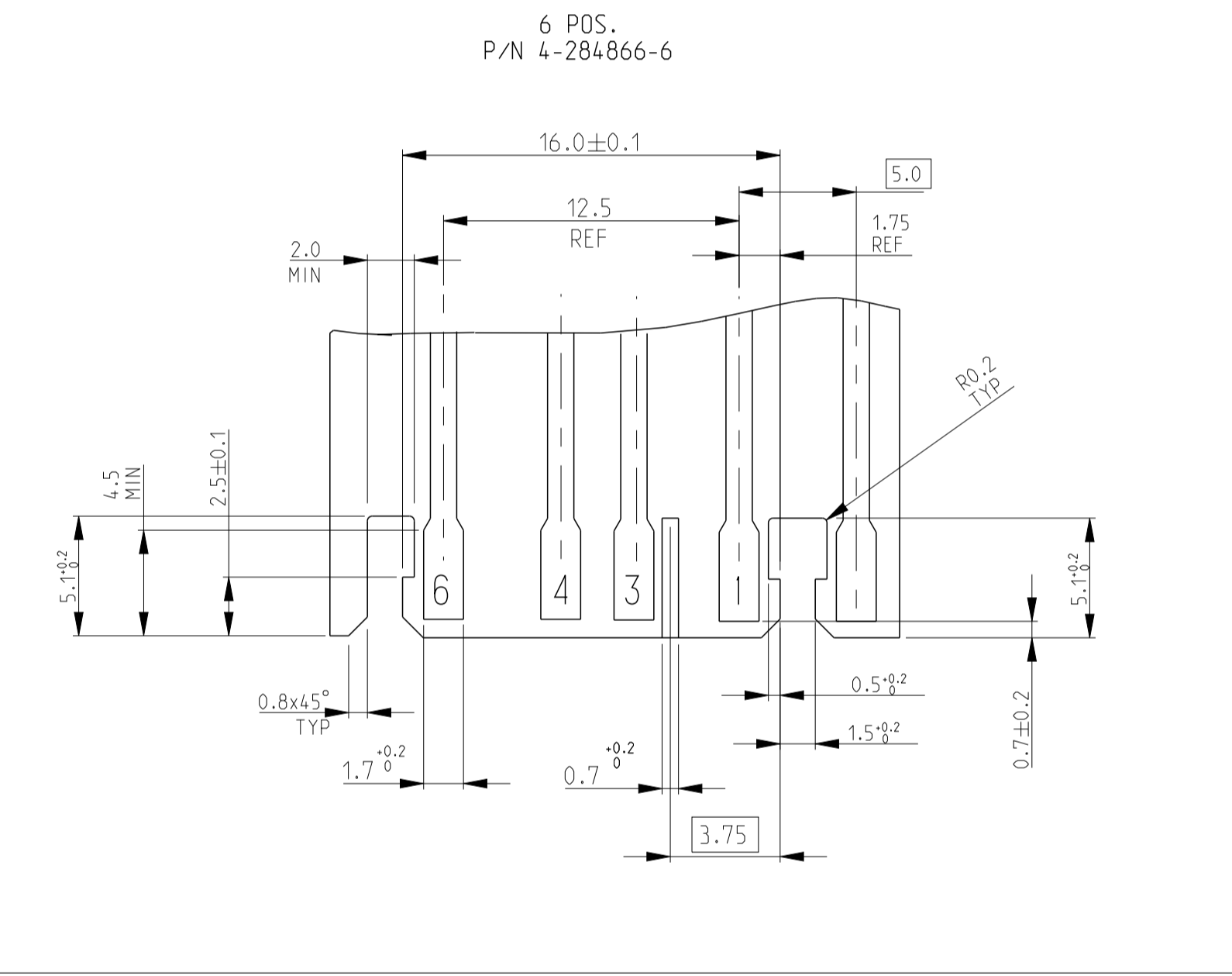
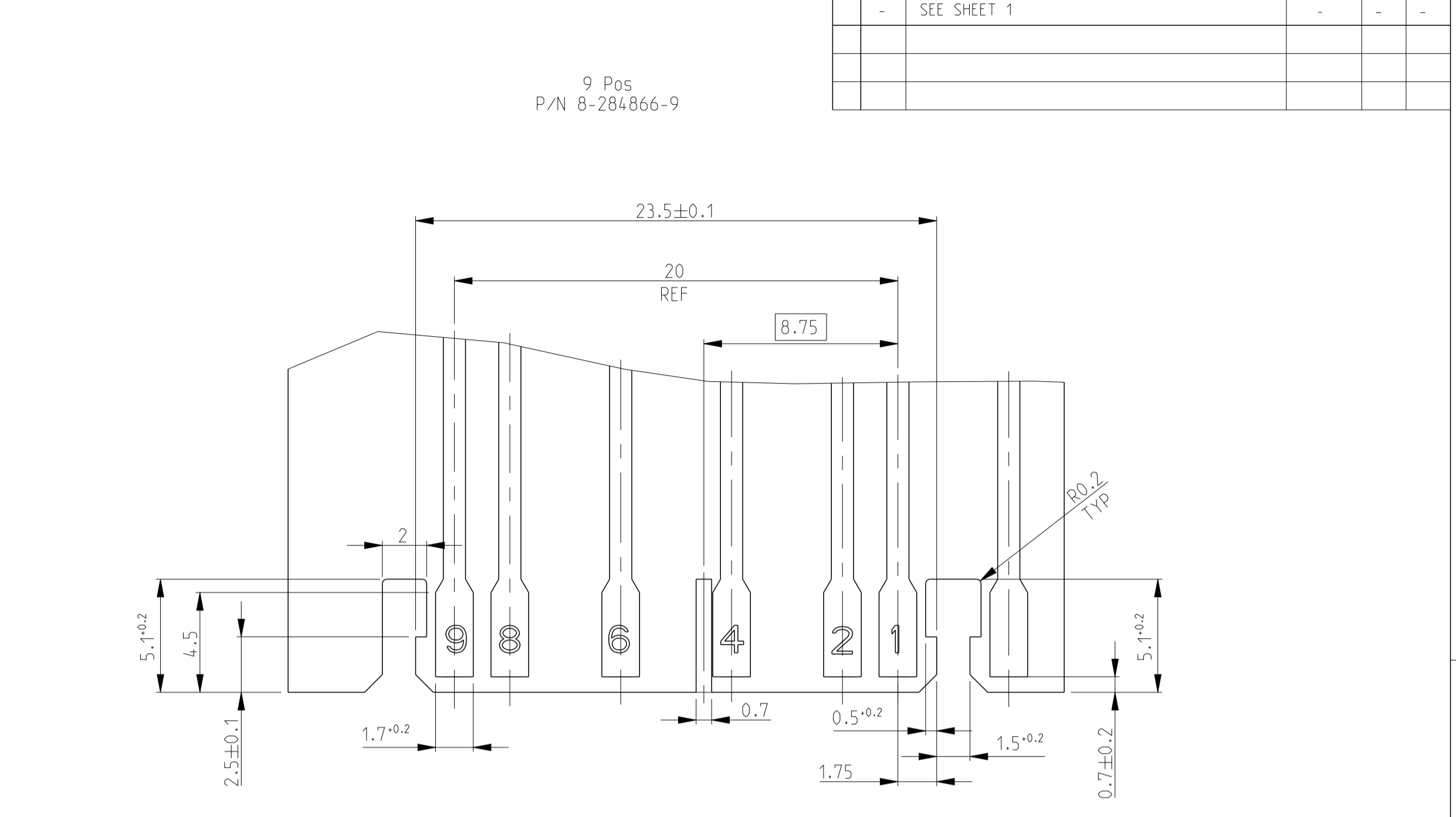
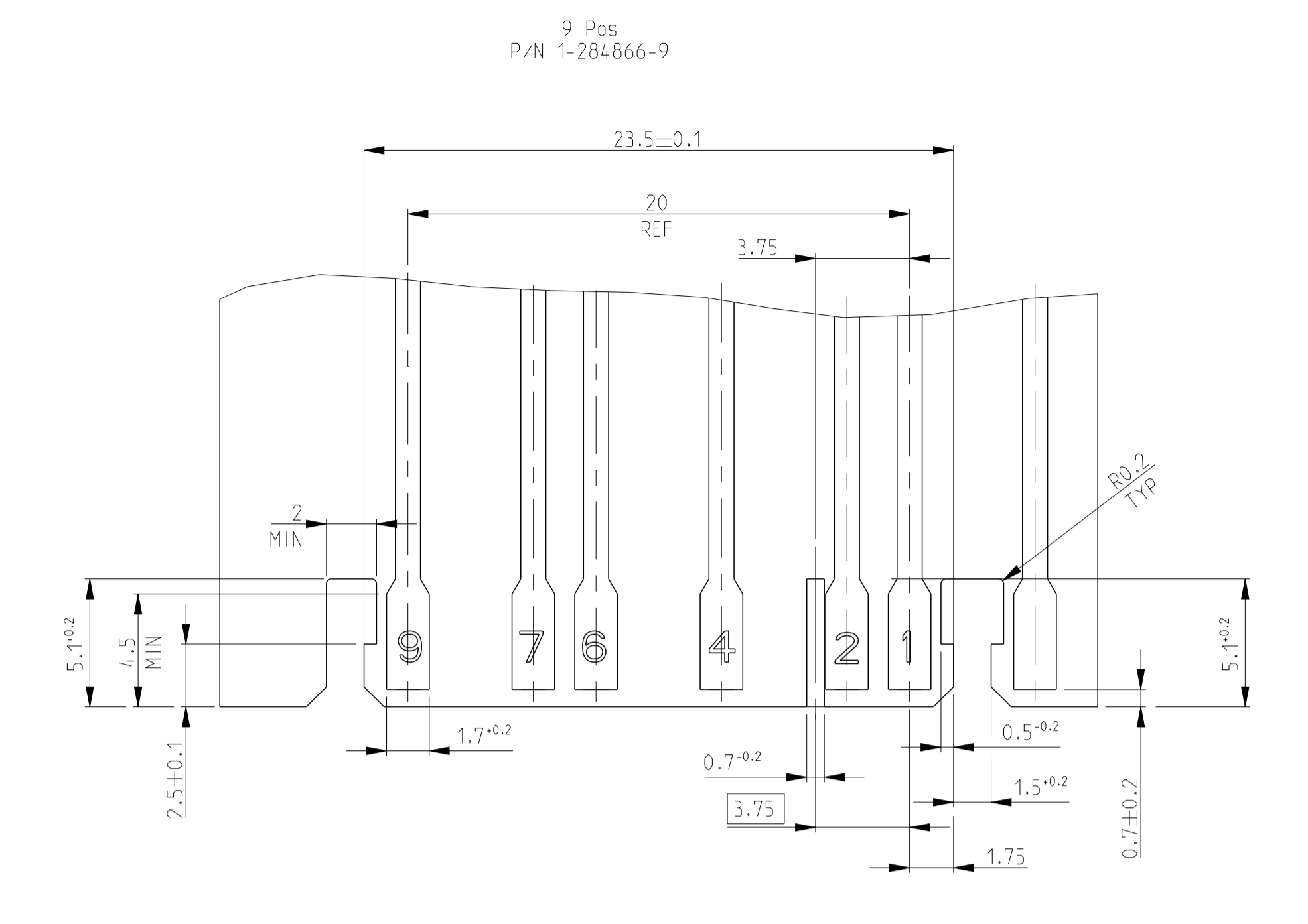
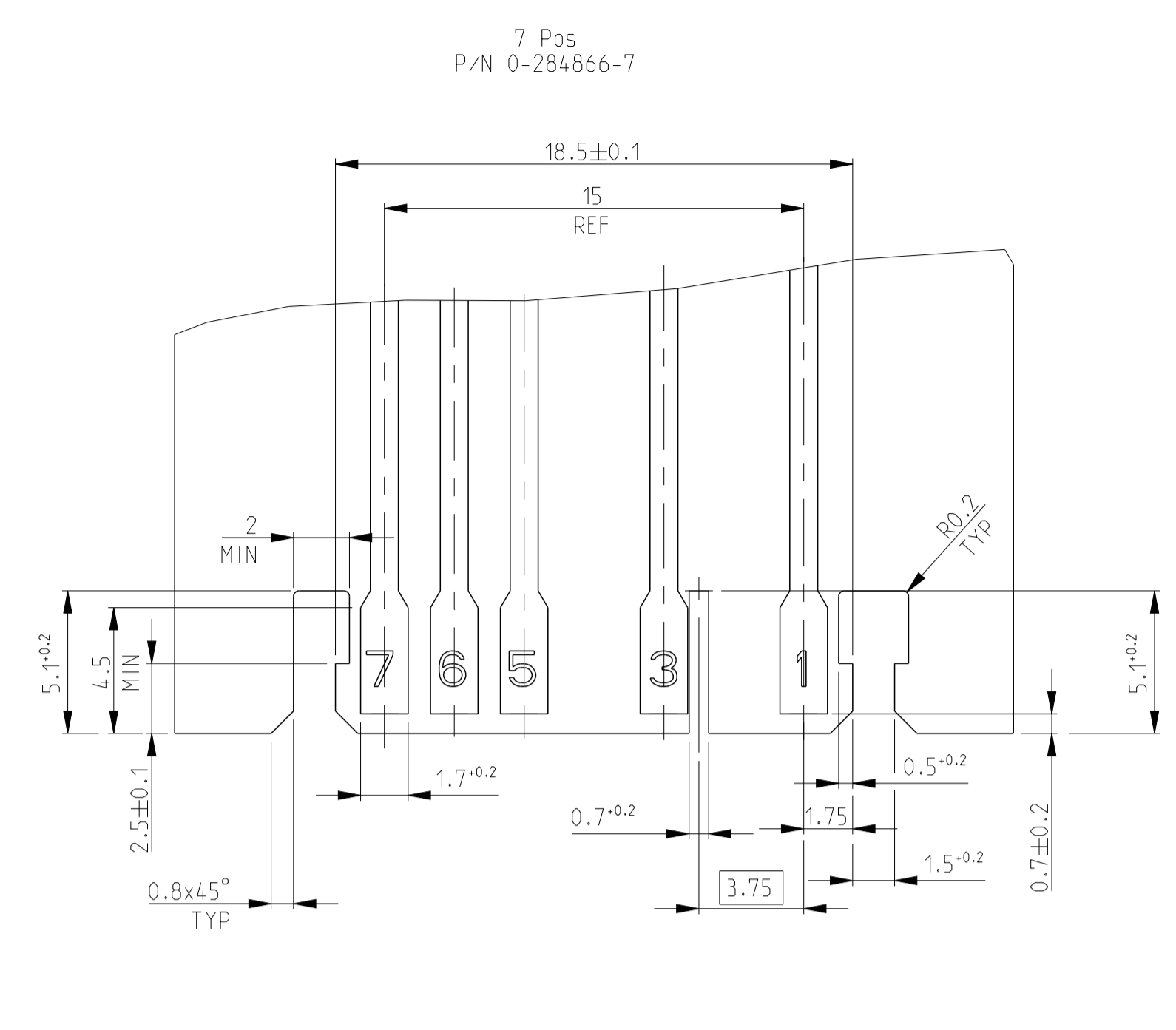

THIS DRAWING IS A CONTROLLED DOCUMENT. DWN R. FABRIS 03JUL2002  
 CHK -

DIMENSIONS: mm  
 TOLERANCES UNLESS OTHERWISE SPECIFIED:  
 0 PLC # # # # #  
 1 PLC # # # # #  
 2 PLC # # # # #  
 3 PLC # # # # #  
 4 PLC # # # # #  
 ANGLES # # # # #  
 FINISH # # # # #

MATERIAL: SEE TABLE  
 FINISH: SEE TABLE

WEIGHT: -  
 CUSTOMER DRAWING

APVD: STURCO  
 PRODUCT SPEC: 108-20238  
 APPLICATION SPEC: 116-18049-1

NAME: DUOPLUG 2.5 FEMALE CONN., SIDE LOCKING, KEYED (SELECTIVELY LOADED CONTACTS)  
 SIZE: A1  
 CAGE CODE: 00779  
 DRAWING NO: 284866

RESTRICTED TO: -

SCALE: 10:1  
 SHEET: 4 OF 4  
 REV: B12

STE TE Connectivity

Компания «Life Electronics» занимается поставками электронных компонентов импортного и отечественного производства от производителей и со складов крупных дистрибьюторов Европы, Америки и Азии.

С конца 2013 года компания активно расширяет линейку поставок компонентов по направлению коаксиальный кабель, кварцевые генераторы и конденсаторы (керамические, пленочные, электролитические), за счёт заключения дистрибьюторских договоров

Мы предлагаем:

- Конкуренспособные цены и скидки постоянным клиентам.
- Специальные условия для постоянных клиентов.
- Подбор аналогов.
- Поставку компонентов в любых объемах, удовлетворяющих вашим потребностям.
- Приемлемые сроки поставки, возможна ускоренная поставка.
- Доставку товара в любую точку России и стран СНГ.
- Комплексную поставку.
- Работу по проектам и поставку образцов.
- Формирование склада под заказчика.
- Сертификаты соответствия на поставляемую продукцию (по желанию клиента).
- Тестирование поставляемой продукции.
- Поставку компонентов, требующих военную и космическую приемку.
- Входной контроль качества.
- Наличие сертификата ISO.

В составе нашей компании организован Конструкторский отдел, призванный помогать разработчикам, и инженерам.

Конструкторский отдел помогает осуществить:

- Регистрацию проекта у производителя компонентов.
- Техническую поддержку проекта.
- Защиту от снятия компонента с производства.
- Оценку стоимости проекта по компонентам.
- Изготовление тестовой платы монтаж и пусконаладочные работы.



Тел: +7 (812) 336 43 04 (многоканальный)

Email: [org@lifeelectronics.ru](mailto:org@lifeelectronics.ru)