

# MC14518B, MC14520B

## Dual Up Counters

The MC14518B dual BCD counter and the MC14520B dual binary counter are constructed with MOS P-channel and N-channel enhancement mode devices in a single monolithic structure. Each consists of two identical, independent, internally synchronous 4-stage counters. The counter stages are type D flip-flops, with interchangeable Clock and Enable lines for incrementing on either the positive-going or negative-going transition as required when cascading multiple stages. Each counter can be cleared by applying a high level on the Reset line. In addition, the MC14518B will count out of all undefined states within two clock periods. These complementary MOS up counters find primary use in multi-stage synchronous or ripple counting applications requiring low power dissipation and/or high noise immunity.

### Features

- Diode Protection on All Inputs
- Supply Voltage Range = 3.0 Vdc to 18 Vdc
- Internally Synchronous for High Internal and External Speeds
- Logic Edge-Clocked Design — Incremented on Positive Transition of Clock or Negative Transition on Enable
- Capable of Driving Two Low-power TTL Loads or One Low-power Schottky TTL Load Over the Rated Temperature Range
- These Devices are Pb-Free and are RoHS Compliant

### MAXIMUM RATINGS (Voltages Referenced to $V_{SS}$ ) (Note 1.)

| Symbol            | Parameter   | Value                  | Unit        |
|-------------------|---|------------------------|-------------|
| $V_{DD}$          | DC Supply Voltage Range                           | -0.5 to +18.0          | V           |
| $V_{in}, V_{out}$ | Input or Output Voltage Range (DC or Transient)   | -0.5 to $V_{DD} + 0.5$ | V           |
| $I_{in}, I_{out}$ | Input or Output Current (DC or Transient) per Pin | $\pm 10$               | mA          |
| $P_D$             | Power Dissipation, per Package (Note 2.)          | 500                    | mW          |
| $T_A$             | Operating Temperature Range                       | -55 to +125            | $^{\circ}C$ |
| $T_{stg}$         | Storage Temperature Range                         | -65 to +150            | $^{\circ}C$ |
| $T_L$             | Lead Temperature (8-Second Soldering)             | 260                    | $^{\circ}C$ |

Maximum ratings are those values beyond which device damage can occur. Maximum ratings applied to the device are individual stress limit values (not normal operating conditions) and are not valid simultaneously. If these limits are exceeded, device functional operation is not implied, damage may occur and reliability may be affected.

1. Maximum Ratings are those values beyond which damage to the device may occur.

2. Temperature Derating:

Plastic "P and D/DW" Packages: -7.0 mW/ $^{\circ}C$  From 65 $^{\circ}C$  To 125 $^{\circ}C$

This device contains protection circuitry to guard against damage due to high static voltages or electric fields. However, precautions must be taken to avoid applications of any voltage higher than maximum rated voltages to this high-impedance circuit. For proper operation,  $V_{in}$  and  $V_{out}$  should be constrained to the range  $V_{SS} \leq (V_{in} \text{ or } V_{out}) \leq V_{DD}$ .

Unused inputs must always be tied to an appropriate logic voltage level (e.g., either  $V_{SS}$  or  $V_{DD}$ ). Unused outputs must be left open.



**ON Semiconductor**

<http://onsemi.com>

### MARKING DIAGRAMS

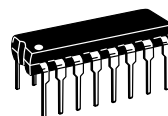

**PDIP-16**  
**P SUFFIX**  
**CASE 648**

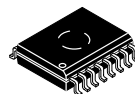
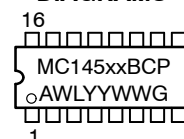

**SO-16 WB**  
**DW SUFFIX**  
**CASE 751G**

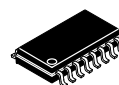
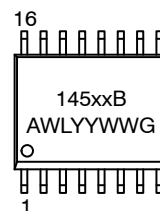

**SOEIAJ-16**  
**F SUFFIX**  
**CASE 966**

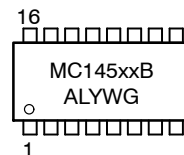

xx = 18 or 20  
A = Assembly Location  
WL, L = Wafer Lot  
YY, Y = Year  
WW, W = Work Week  
G = Pb-Free Indicator

### ORDERING INFORMATION

See detailed ordering and shipping information in the package dimensions section on page 7 of this data sheet.

# MC14518B, MC14520B

## PIN ASSIGNMENT

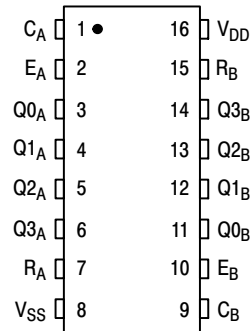

## BLOCK DIAGRAM

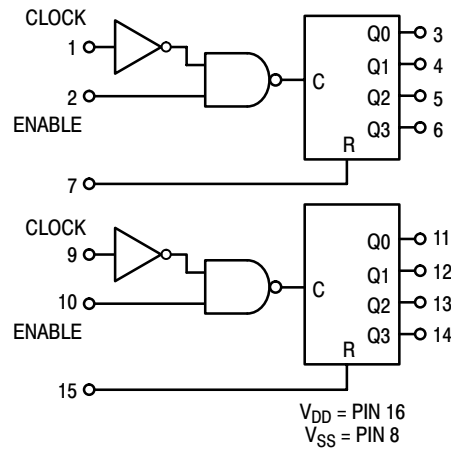

## TRUTH TABLE

| Clock | Enable | Reset | Action            |
|-------|--------|-------|-------------------|
| ↗     | 1      | 0     | Increment Counter |
| 0     | ↘      | 0     | Increment Counter |
| ↘     | X      | 0     | No Change         |
| X     | ↗      | 0     | No Change         |
| ↗     | 0      | 0     | No Change         |
| 1     | ↘      | 0     | No Change         |
| X     | X      | 1     | Q0 thru Q3 = 0    |

X = Don't Care

# MC14518B, MC14520B

## ELECTRICAL CHARACTERISTICS (Voltages Referenced to V<sub>SS</sub>)

| Characteristic   | Symbol                       | V <sub>DD</sub><br>Vdc | - 55°C  |       | 25°C  |                     |       | 125°C |       | Unit |      |
|--|------------------------------|------------------------|---|-------|-------|---------------------|-------|-------|-------|------|------|
|  |                              |                        | Min   | Max   | Min   | Typ <sup>(3.)</sup> | Max   | Min   | Max   |      |      |
| Output Voltage<br>V <sub>in</sub> = V <sub>DD</sub> or 0<br><br>V <sub>in</sub> = 0 or V <sub>DD</sub>   | “0” Level<br>V <sub>OL</sub> | 5.0                    | —   | 0.05  | —     | 0                   | 0.05  | —     | 0.05  | Vdc  |      |
|  |                              | 10                     | —   | 0.05  | —     | 0                   | 0.05  | —     | 0.05  |      |      |
|  |                              | 15                     | —   | 0.05  | —     | 0                   | 0.05  | —     | 0.05  |      |      |
|  | “1” Level<br>V <sub>OH</sub> | 5.0                    | 4.95  | —     | 4.95  | 5.0                 | —     | 4.95  | —     |      |      |
|  |                              | 10                     | 9.95  | —     | 9.95  | 10                  | —     | 9.95  | —     |      |      |
|  |                              | 15                     | 14.95   | —     | 14.95 | 15                  | —     | 14.95 | —     |      |      |
| Input Voltage<br>(V <sub>O</sub> = 4.5 or 0.5 Vdc)<br>(V <sub>O</sub> = 9.0 or 1.0 Vdc)<br>(V <sub>O</sub> = 13.5 or 1.5 Vdc)<br><br>(V <sub>O</sub> = 0.5 or 4.5 Vdc)<br>(V <sub>O</sub> = 1.0 or 9.0 Vdc)<br>(V <sub>O</sub> = 1.5 or 13.5 Vdc)  | “0” Level<br>V <sub>IL</sub> | 5.0                    | —   | 1.5   | —     | 2.25                | 1.5   | —     | 1.5   | Vdc  |      |
|  |                              | 10                     | —   | 3.0   | —     | 4.50                | 3.0   | —     | 3.0   |      |      |
|  |                              | 15                     | —   | 4.0   | —     | 6.75                | 4.0   | —     | 4.0   |      |      |
|  | “1” Level<br>V <sub>IH</sub> | 5.0                    | 3.5   | —     | 3.5   | 2.75                | —     | 3.5   | —     |      |      |
|  |                              | 10                     | 7.0   | —     | 7.0   | 5.50                | —     | 7.0   | —     |      |      |
|  |                              | 15                     | 11  | —     | 11    | 8.25                | —     | 11    | —     |      |      |
| Output Drive Current<br>(V <sub>OH</sub> = 2.5 Vdc)<br>(V <sub>OH</sub> = 4.6 Vdc)<br>(V <sub>OH</sub> = 9.5 Vdc)<br>(V <sub>OH</sub> = 13.5 Vdc)<br><br>(V <sub>OL</sub> = 0.4 Vdc)<br>(V <sub>OL</sub> = 0.5 Vdc)<br>(V <sub>OL</sub> = 1.5 Vdc) | Source<br>I <sub>OH</sub>    | 5.0                    | -3.0  | —     | -2.4  | -4.2                | —     | -1.7  | —     | mAdc |      |
|  |                              | 5.0                    | -0.64   | —     | -0.51 | -0.88               | —     | -0.36 | —     |      |      |
|  |                              | 10                     | -1.6  | —     | -1.3  | -2.25               | —     | -0.9  | —     |      |      |
|  |                              | 15                     | -4.2  | —     | -3.4  | -8.8                | —     | -2.4  | —     |      |      |
|  | Sink<br>I <sub>OL</sub>      | 5.0                    | 0.64  | —     | 0.51  | 0.88                | —     | 0.36  | —     |      | mAdc |
|  |                              | 10                     | 1.6   | —     | 1.3   | 2.25                | —     | 0.9   | —     |      |      |
| 15   | 4.2                          | —                      | 3.4   | 8.8   | —     | 2.4                 | —     | —     |       |      |      |
| Input Current  | I <sub>in</sub>              | 15                     | —   | ± 0.1 | —     | ± 0.00001           | ± 0.1 | —     | ± 1.0 | μAdc |      |
| Input Capacitance<br>(V <sub>in</sub> = 0)   | C <sub>in</sub>              | —                      | —   | —     | —     | 5.0                 | 7.5   | —     | —     | pF   |      |
| Quiescent Current<br>(Per Package)   | I <sub>DD</sub>              | 5.0                    | —   | 5.0   | —     | 0.005               | 5.0   | —     | 150   | μAdc |      |
|  |                              | 10                     | —   | 10    | —     | 0.010               | 10    | —     | 300   |      |      |
|  |                              | 15                     | —   | 20    | —     | 0.015               | 20    | —     | 600   |      |      |
| Total Supply Current <sup>(4.)</sup> <sup>(5.)</sup><br>(Dynamic plus Quiescent,<br>Per Package)<br>(C <sub>L</sub> = 50 pF on all outputs, all<br>buffers switching)  | I <sub>T</sub>               | 5.0                    | I <sub>T</sub> = (0.6 μA/kHz) f + I <sub>DD</sub> |       |       |                     |       |       |       | μAdc |      |
|  |                              | 10                     | I <sub>T</sub> = (1.2 μA/kHz) f + I <sub>DD</sub> |       |       |                     |       |       |       |      |      |
|  |                              | 15                     | I <sub>T</sub> = (1.7 μA/kHz) f + I <sub>DD</sub> |       |       |                     |       |       |       |      |      |

3. Data labelled “Typ” is not to be used for design purposes but is intended as an indication of the IC’s potential performance.

4. The formulas given are for the typical characteristics only at 25°C.

5. To calculate total supply current at loads other than 50 pF:

$$I_T(C_L) = I_T(50 \text{ pF}) + (C_L - 50) Vfk$$

where: I<sub>T</sub> is in μA (per package), C<sub>L</sub> in pF, V = (V<sub>DD</sub> - V<sub>SS</sub>) in volts, f in kHz is input frequency, and k = 0.002.

# MC14518B, MC14520B

## SWITCHING CHARACTERISTICS (6.) ( $C_L = 50 \text{ pF}$ , $T_A = 25^\circ\text{C}$ )

| Characteristic   | Symbol  | $V_{DD}$                               | All Types                      |  |  | Unit          |
|--|---|--|--------------------------------|--|--|---------------|
|  |   |  | Min                            | Typ (7.)                                 | Max  |               |
| Output Rise and Fall Time<br>$t_{TLH}$ , $t_{THL} = (1.5 \text{ ns/pF}) C_L + 25 \text{ ns}$<br>$t_{TLH}$ , $t_{THL} = (0.75 \text{ ns/pF}) C_L + 12.5 \text{ ns}$<br>$t_{TLH}$ , $t_{THL} = (0.55 \text{ ns/pF}) C_L + 9.5 \text{ ns}$  | $t_{TLH}$ ,<br>$t_{THL}$  | 5.0<br>10<br>15                        | —<br>—<br>—                    | 100<br>50<br>40                          | 200<br>100<br>80                           | ns            |
| Propagation Delay Time<br>Clock to Q/Enable to Q<br>$t_{PLH}$ , $t_{PHL} = (1.7 \text{ ns/pF}) C_L + 215 \text{ ns}$<br>$t_{PLH}$ , $t_{PHL} = (0.66 \text{ ns/pF}) C_L + 97 \text{ ns}$<br>$t_{PLH}$ , $t_{PHL} = (0.5 \text{ ns/pF}) C_L + 75 \text{ ns}$<br><br>Reset to Q<br>$t_{PHL} = (1.7 \text{ ns/pF}) C_L + 265 \text{ ns}$<br>$t_{PHL} = (0.66 \text{ ns/pF}) C_L + 117 \text{ ns}$<br>$t_{PHL} = (0.66 \text{ ns/pF}) C_L + 95 \text{ ns}$ | $t_{PLH}$ ,<br>$t_{PHL}$<br><br><br><br><br><br><br><br>$t_{PHL}$ | 5.0<br>10<br>15<br><br>5.0<br>10<br>15 | —<br>—<br>—<br><br>—<br>—<br>— | 280<br>115<br>80<br><br>330<br>130<br>90 | 560<br>230<br>160<br><br>650<br>230<br>170 | ns            |
| Clock Pulse Width  | $t_{w(H)}$<br>$t_{w(L)}$  | 5.0<br>10<br>15                        | 200<br>100<br>70               | 100<br>50<br>35                          | —<br>—<br>—                                | ns            |
| Clock Pulse Frequency  | $f_{cl}$  | 5.0<br>10<br>15                        | —<br>—<br>—                    | 2.5<br>6.0<br>8.0                        | 1.5<br>3.0<br>4.0                          | MHz           |
| Clock or Enable Rise and Fall Time   | $t_{THL}$ , $t_{TLH}$   | 5.0<br>10<br>15                        | —<br>—<br>—                    | —<br>—<br>—                              | 15<br>5<br>4                               | $\mu\text{s}$ |
| Enable Pulse Width   | $t_{WH(E)}$   | 5.0<br>10<br>15                        | 440<br>200<br>140              | 220<br>100<br>70                         | —<br>—<br>—                                | ns            |
| Reset Pulse Width  | $t_{WH(R)}$   | 5.0<br>10<br>15                        | 280<br>120<br>90               | 125<br>55<br>40                          | —<br>—<br>—                                | ns            |
| Reset Removal Time   | $t_{rem}$   | 5.0<br>10<br>15                        | -5<br>15<br>20                 | -45<br>-15<br>-5                         | —<br>—<br>—                                | ns            |

6. The formulas given are for the typical characteristics only at  $25^\circ\text{C}$ .

7. Data labelled "Typ" is not to be used for design purposes but is intended as an indication of the IC's potential performance.

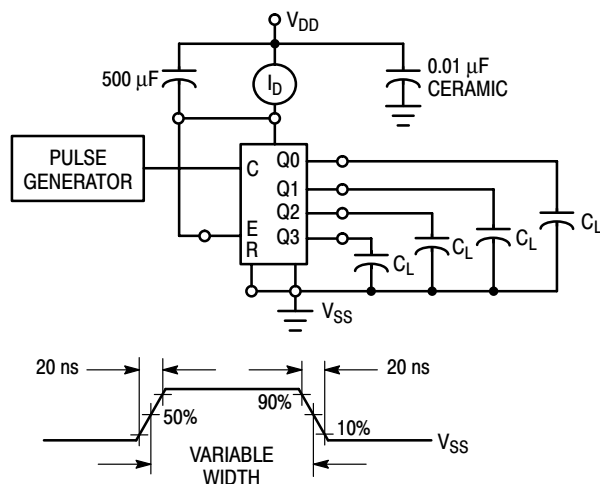

Figure 1. Power Dissipation Test Circuit and Waveform

# MC14518B, MC14520B

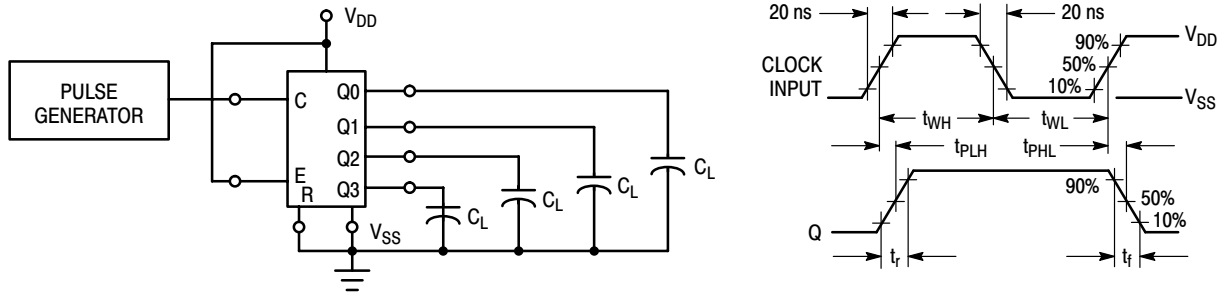

Figure 2. Switching Time Test Circuit and Waveforms

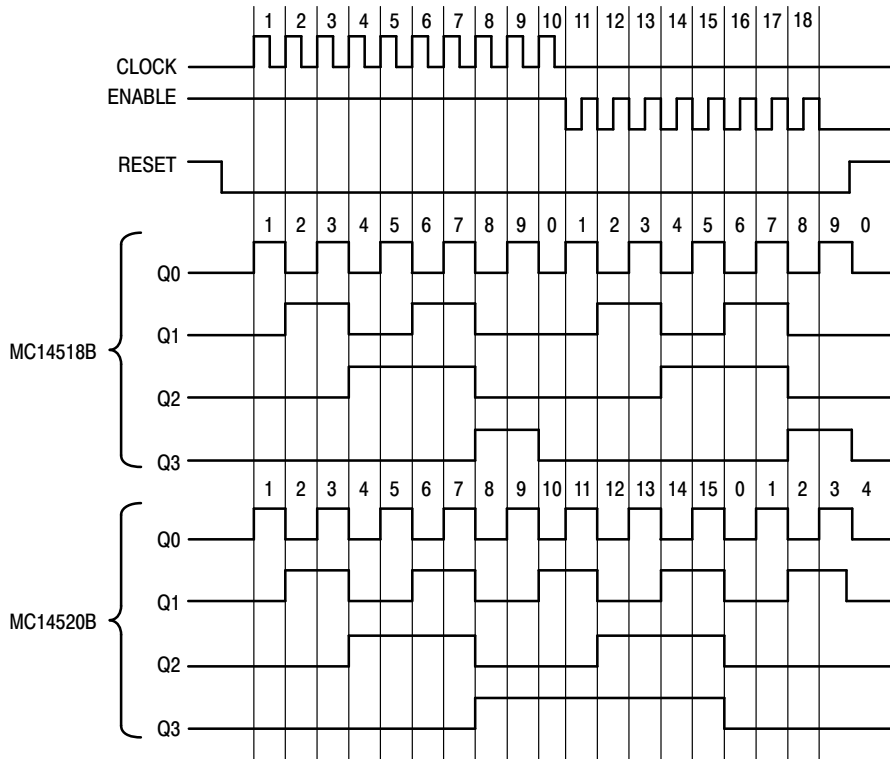

Figure 3. Timing Diagram

# MC14518B, MC14520B

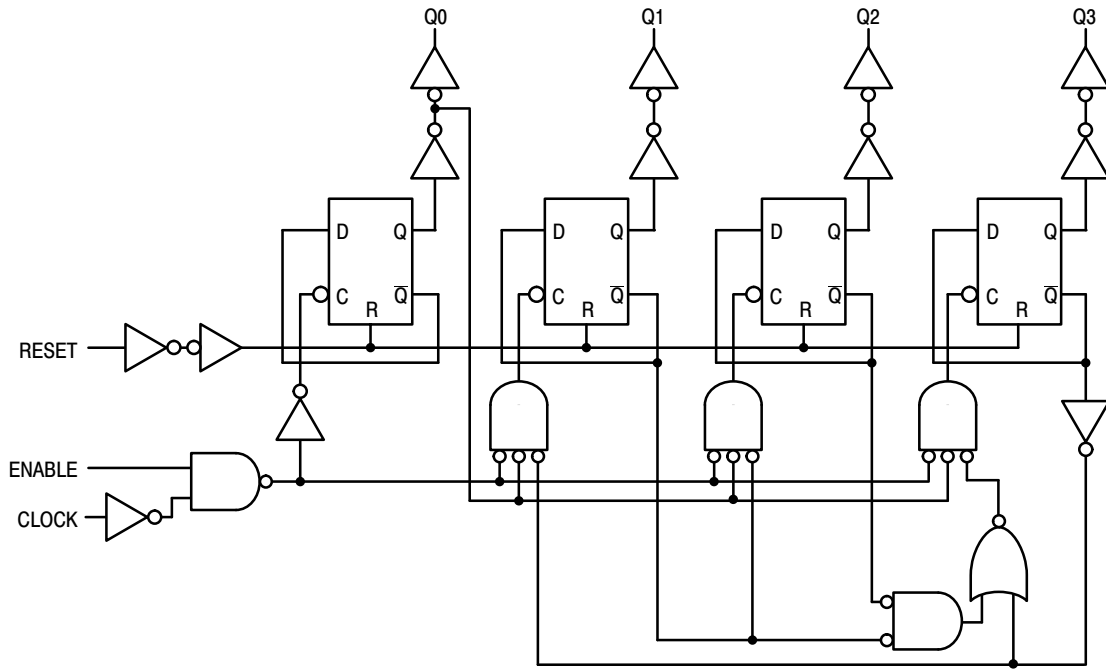

Figure 4. Decade Counter (MC14518B) Logic Diagram  
(1/2 of Device Shown)

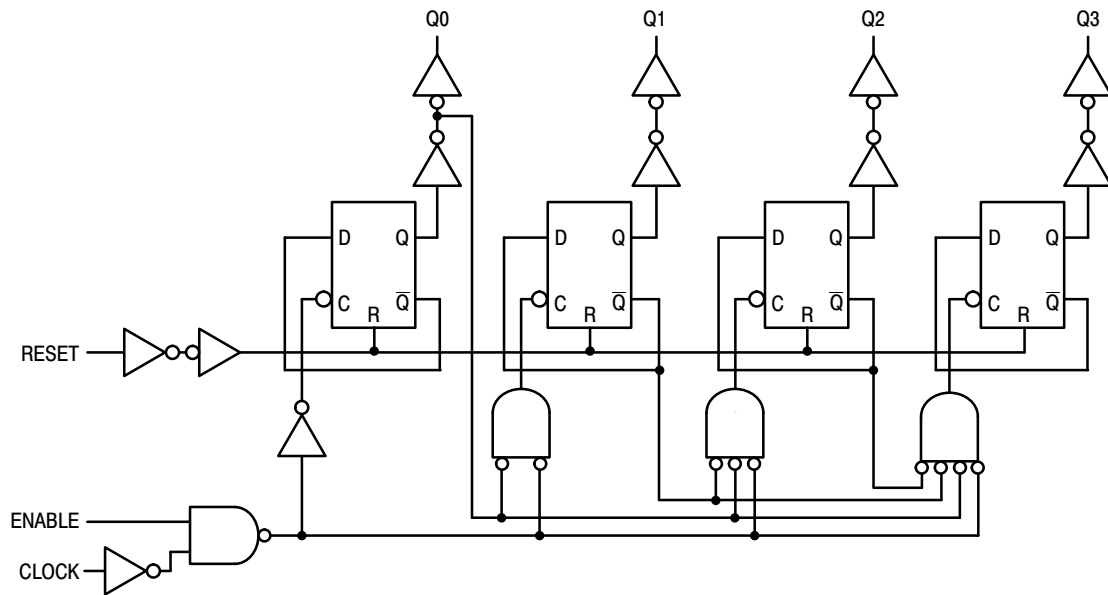

Figure 5. Binary Counter (MC14520B) Logic Diagram  
(1/2 of Device Shown)

## MC14518B, MC14520B

### ORDERING INFORMATION

| Device        | Package                | Shipping†                |
|---------------|------------------------|--------------------------|
| MC14518BCPG   | PDIP-16<br>(Pb-Free)   | 500 Units / Rail         |
| MC14518BDWG   | SO-16 WB<br>(Pb-Free)  | 47 Units / Rail          |
| MC14518BDWR2G | SO-16 WB<br>(Pb-Free)  | 1000 Units / Tape & Reel |
| MC14518BFELG  | SOEIAJ-16<br>(Pb-Free) | 2000 Units / Tape & Reel |
| MC14520BCPG   | PDIP-16<br>(Pb-Free)   | 500 Units / Rail         |
| MC14520BDWG   | SO-16 WB<br>(Pb-Free)  | 47 Units / Rail          |
| MC14520BDWR2G | SO-16 WB<br>(Pb-Free)  | 1000 Units / Tape & Reel |
| MC14520BFELG  | SOEIAJ-16<br>(Pb-Free) | 2000 Units / Tape & Reel |

†For information on tape and reel specifications, including part orientation and tape sizes, please refer to our Tape and Reel Packaging Specifications Brochure, BRD8011/D.

# MC14518B, MC14520B

## PACKAGE DIMENSIONS

**PDIP-16**  
**P SUFFIX**  
 PLASTIC DIP PACKAGE  
 CASE 648-08  
 ISSUE T

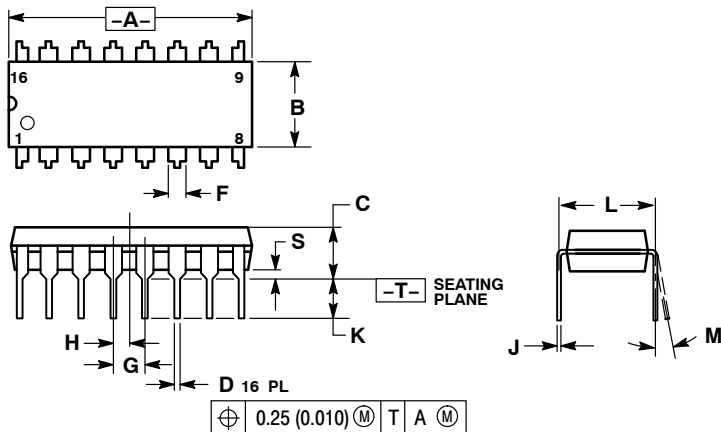

- NOTES:
1. DIMENSIONING AND TOLERANCING PER ANSI Y14.5M, 1982.
  2. CONTROLLING DIMENSION: INCH.
  3. DIMENSION L TO CENTER OF LEADS WHEN FORMED PARALLEL.
  4. DIMENSION B DOES NOT INCLUDE MOLD FLASH.
  5. ROUNDED CORNERS OPTIONAL.

| DIM | INCHES    |       | MILLIMETERS |       |
|-----|-----------|-------|-------------|-------|
|     | MIN       | MAX   | MIN         | MAX   |
| A   | 0.740     | 0.770 | 18.80       | 19.55 |
| B   | 0.250     | 0.270 | 6.35        | 6.85  |
| C   | 0.145     | 0.175 | 3.69        | 4.44  |
| D   | 0.015     | 0.021 | 0.39        | 0.53  |
| F   | 0.040     | 0.70  | 1.02        | 1.77  |
| G   | 0.100 BSC |       | 2.54 BSC    |       |
| H   | 0.050 BSC |       | 1.27 BSC    |       |
| J   | 0.008     | 0.015 | 0.21        | 0.38  |
| K   | 0.110     | 0.130 | 2.80        | 3.30  |
| L   | 0.295     | 0.305 | 7.50        | 7.74  |
| M   | 0°        | 10°   | 0°          | 10°   |
| S   | 0.020     | 0.040 | 0.51        | 1.01  |

**SO-16 WB**  
**DW SUFFIX**  
 PLASTIC SOIC PACKAGE  
 CASE 751G-03  
 ISSUE C

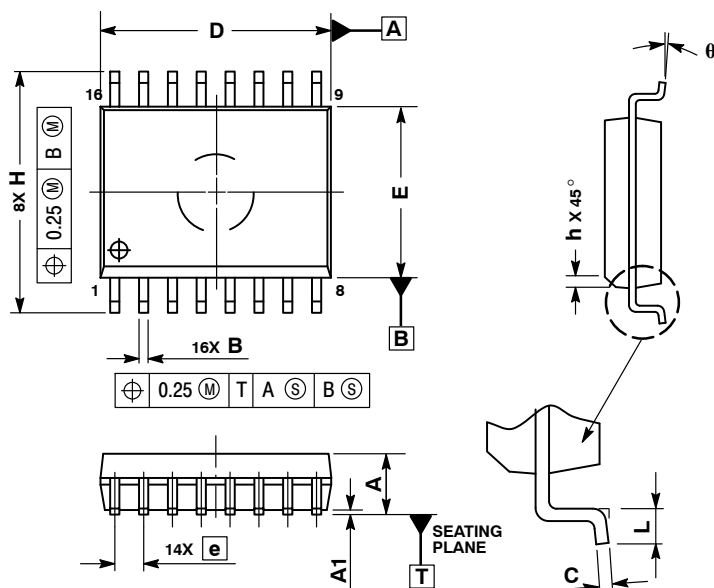

- NOTES:
1. DIMENSIONS ARE IN MILLIMETERS.
  2. INTERPRET DIMENSIONS AND TOLERANCES PER ASME Y14.5M, 1994.
  3. DIMENSIONS D AND E DO NOT INCLUDE MOLD PROTRUSION.
  4. MAXIMUM MOLD PROTRUSION 0.15 PER SIDE.
  5. DIMENSION B DOES NOT INCLUDE DAMBAR PROTRUSION. ALLOWABLE DAMBAR PROTRUSION SHALL BE 0.13 TOTAL IN EXCESS OF THE B DIMENSION AT MAXIMUM MATERIAL CONDITION.

| DIM | MILLIMETERS |       |
|-----|-------------|-------|
|     | MIN         | MAX   |
| A   | 2.35        | 2.65  |
| A1  | 0.10        | 0.25  |
| B   | 0.35        | 0.49  |
| C   | 0.23        | 0.32  |
| D   | 10.15       | 10.45 |
| E   | 7.40        | 7.60  |
| e   | 1.27 BSC    |       |
| H   | 10.05       | 10.55 |
| h   | 0.25        | 0.75  |
| L   | 0.50        | 0.90  |
| q   | 0°          | 7°    |



# MC14518B, MC14520B

## PACKAGE DIMENSIONS

### SOEIAJ-16 F SUFFIX PLASTIC EIAJ SOIC PACKAGE CASE 966-01 ISSUE A

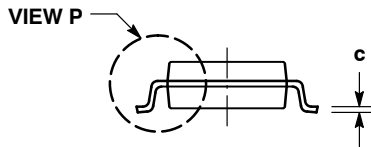
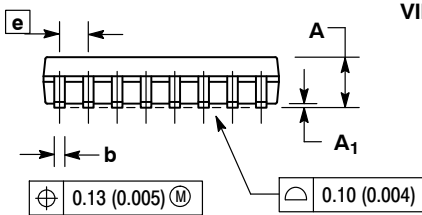
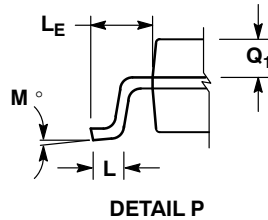
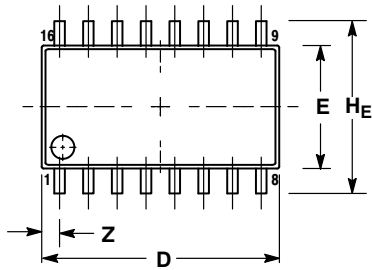

#### NOTES:

1. DIMENSIONING AND TOLERANCING PER ANSI Y14.5M, 1982.
2. CONTROLLING DIMENSION: MILLIMETER.
3. DIMENSIONS D AND E DO NOT INCLUDE MOLD FLASH OR PROTRUSIONS AND ARE MEASURED AT THE PARTING LINE. MOLD FLASH OR PROTRUSIONS SHALL NOT EXCEED 0.15 (0.006) PER SIDE.
4. TERMINAL NUMBERS ARE SHOWN FOR REFERENCE ONLY.
5. THE LEAD WIDTH DIMENSION (b) DOES NOT INCLUDE DAMBAR PROTRUSION. ALLOWABLE DAMBAR PROTRUSION SHALL BE 0.08 (0.003) TOTAL IN EXCESS OF THE LEAD WIDTH DIMENSION AT MAXIMUM MATERIAL CONDITION. DAMBAR CANNOT BE LOCATED ON THE LOWER RADIUS OR THE FOOT. MINIMUM SPACE BETWEEN PROTRUSIONS AND ADJACENT LEAD TO BE 0.46 (0.018).

| DIM            | MILLIMETERS |       | INCHES    |       |
|----------------|-------------|-------|-----------|-------|
|                | MIN         | MAX   | MIN       | MAX   |
| A              | ---         | 2.05  | ---       | 0.081 |
| A <sub>1</sub> | 0.05        | 0.20  | 0.002     | 0.008 |
| b              | 0.35        | 0.50  | 0.014     | 0.020 |
| c              | 0.10        | 0.20  | 0.007     | 0.011 |
| D              | 9.90        | 10.50 | 0.390     | 0.413 |
| E              | 5.10        | 5.45  | 0.201     | 0.215 |
| e              | 1.27 BSC    |       | 0.050 BSC |       |
| HE             | 7.40        | 8.20  | 0.291     | 0.323 |
| L              | 0.50        | 0.85  | 0.020     | 0.033 |
| LE             | 1.10        | 1.50  | 0.043     | 0.059 |
| M              | 0°          | 10°   | 0°        | 10°   |
| Q <sub>1</sub> | 0.70        | 0.90  | 0.028     | 0.035 |
| Z              | ---         | 0.78  | ---       | 0.031 |

ON Semiconductor and are registered trademarks of Semiconductor Components Industries, LLC (SCILLC). SCILLC reserves the right to make changes without further notice to any products herein. SCILLC makes no warranty, representation or guarantee regarding the suitability of its products for any particular purpose, nor does SCILLC assume any liability arising out of the application or use of any product or circuit, and specifically disclaims any and all liability, including without limitation special, consequential or incidental damages. "Typical" parameters which may be provided in SCILLC data sheets and/or specifications can and do vary in different applications and actual performance may vary over time. All operating parameters, including "Typicals" must be validated for each customer application by customer's technical experts. SCILLC does not convey any license under its patent rights nor the rights of others. SCILLC products are not designed, intended, or authorized for use as components in systems intended for surgical implant into the body, or other applications intended to support or sustain life, or for any other application in which the failure of the SCILLC product could create a situation where personal injury or death may occur. Should Buyer purchase or use SCILLC products for any such unintended or unauthorized application, Buyer shall indemnify and hold SCILLC and its officers, employees, subsidiaries, affiliates, and distributors harmless against all claims, costs, damages, and expenses, and reasonable attorney fees arising out of, directly or indirectly, any claim of personal injury or death associated with such unintended or unauthorized use, even if such claim alleges that SCILLC was negligent regarding the design or manufacture of the part. SCILLC is an Equal Opportunity/Affirmative Action Employer. This literature is subject to all applicable copyright laws and is not for resale in any manner.

#### PUBLICATION ORDERING INFORMATION

**LITERATURE FULFILLMENT:**  
Literature Distribution Center for ON Semiconductor  
P.O. Box 5163, Denver, Colorado 80217 USA  
**Phone:** 303-675-2175 or 800-344-3860 Toll Free USA/Canada  
**Fax:** 303-675-2176 or 800-344-3867 Toll Free USA/Canada  
**Email:** orderlit@onsemi.com

**N. American Technical Support:** 800-282-9855 Toll Free  
USA/Canada  
**Europe, Middle East and Africa Technical Support:**  
Phone: 421 33 790 2910  
**Japan Customer Focus Center**  
Phone: 81-3-5773-3850

**ON Semiconductor Website:** [www.onsemi.com](http://www.onsemi.com)  
**Order Literature:** <http://www.onsemi.com/orderlit>

For additional information, please contact your local Sales Representative

Компания «Life Electronics» занимается поставками электронных компонентов импортного и отечественного производства от производителей и со складов крупных дистрибьюторов Европы, Америки и Азии.

С конца 2013 года компания активно расширяет линейку поставок компонентов по направлению коаксиальный кабель, кварцевые генераторы и конденсаторы (керамические, пленочные, электролитические), за счёт заключения дистрибьюторских договоров

Мы предлагаем:

- Конкурентоспособные цены и скидки постоянным клиентам.
- Специальные условия для постоянных клиентов.
- Подбор аналогов.
- Поставку компонентов в любых объемах, удовлетворяющих вашим потребностям.
- Приемлемые сроки поставки, возможна ускоренная поставка.
- Доставку товара в любую точку России и стран СНГ.
- Комплексную поставку.
- Работу по проектам и поставку образцов.
- Формирование склада под заказчика.
- Сертификаты соответствия на поставляемую продукцию (по желанию клиента).
- Тестирование поставляемой продукции.
- Поставку компонентов, требующих военную и космическую приемку.
- Входной контроль качества.
- Наличие сертификата ISO.

В составе нашей компании организован Конструкторский отдел, призванный помогать разработчикам, и инженерам.

Конструкторский отдел помогает осуществить:

- Регистрацию проекта у производителя компонентов.
- Техническую поддержку проекта.
- Защиту от снятия компонента с производства.
- Оценку стоимости проекта по компонентам.
- Изготовление тестовой платы монтаж и пусконаладочные работы.



Тел: +7 (812) 336 43 04 (многоканальный)

Email: [org@lifeelectronics.ru](mailto:org@lifeelectronics.ru)