

MU Type Fiber Optic Connectors

HMU Series

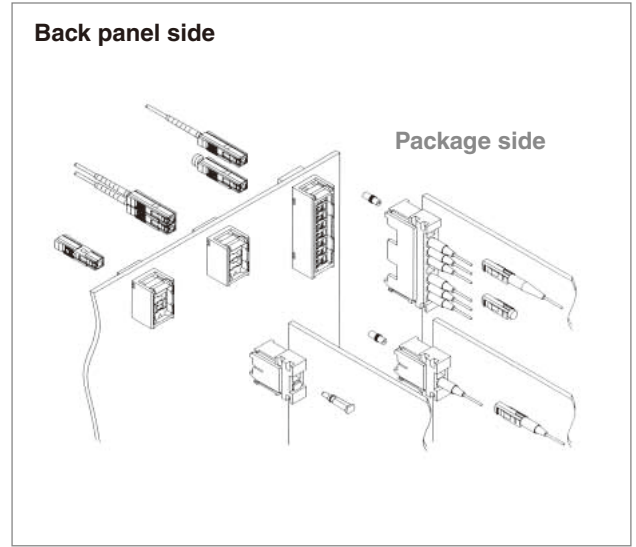
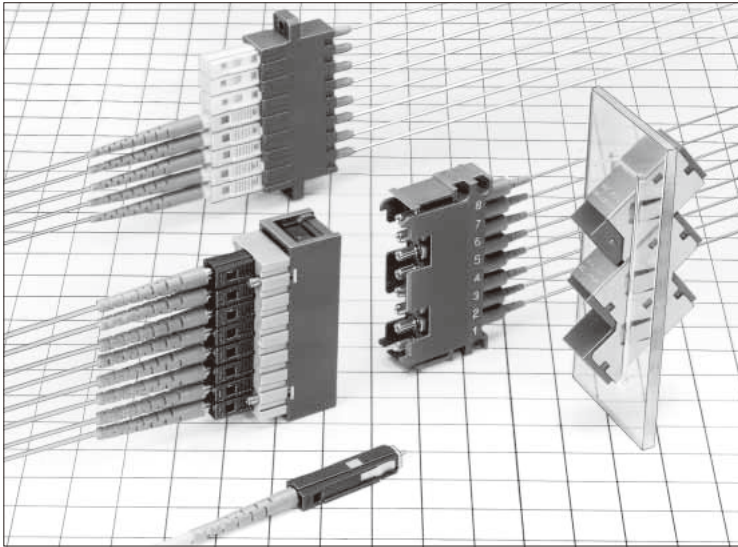

■ Features

1. IEC, JIS standard compliant and intermateability test certified.

Comply with JIS C 5983 (F14 type fiber optic connectors) and IEC 61754-6.

MU intermate test by NTT certified connector.

2. Flame resistant

Satisfies flammability rating UL94V-0

3. Backplane

MU Backplane connector has a self-holding mechanism which does not transfer any force on the back panel when both side of connector assemblies are fully connected. Back panel side connectors can be removed or inserted even both sides are mated.

4. Wide Variety of adapter type

Type	Number of Fiber connections				
	Single	Duplex	4 way	8 way	16 way
Board Mounting	✓	✓	—	✓	—
Snap-in Panel Mounting & Screw Panel Mounting	✓	✓	✓ (Only Snap-in)	✓	✓

5. Simplified plugs and Receptacles

Extremely small size (only 13.75mm Plug length). MU simplified plug is designed for equipments inside connection.

■ Product Specifications

Ratings		Operating temperature range		-25°C to +70°C	Storage temperature range		-25°C to +70°C	
Item		Test Method (IEC 61300)			Specifications			
Optical Characteristics	Insertion Loss	SM	Wavelength 1310nm (LD)		0.5dB max. (AdPC)			
		MM(GI)	Wavelength 1310nm (LED)		0.3dB max. (PC)			
	Return Loss	SM	Wavelength 1310nm (LD)		40dB min.(AdPC)			
		MM(GI)			22dB min.(PC)			
Mechanical Characteristics	Engagement and Separation forces		Measured with corresponding connector.			Simplex plug	Engagement force: 20 N max. Separation force: 20 N max.	
	Ferrule with drawal force		Extract zirconia gauge 1.249 ±0.0005 mm diameter from split sleeve.			Duplex plug	Engagement force: 30 N max. Separation force: 30 N max.	
	Cable retention (Straight pull)		70N tensile loads for one minute.			Copper alloy split sleeve	1N to 3N	
	Durability (cycles, mating/un-mating)		200 times (Backplane) 500 times (Plug)			Zirconia split sleeve	1N to 2.5N	
	Vibration		Frequency: 10 to 55 Hz, single amplitude of 0.75 mm, 2 hours in each of the 3 axis.			1) Insertion loss fluctuation after test: 0.2dB max. 2) No visible damage, dislocation of clamp or cable.		
	Shock		Acceleration of 981 m/s ² , 6 ms duration, sin half-wave waveform, 10 cycles in each of the 3 axis.					
Environmental Characteristics	Humidity (Temperature/ humidity- cycles)		-10°C to 65°C, humidity: 90% to 96% 10 cycles			1) Insertion loss fluctuation after test: 0.2dB max. 2) No visible damage, cracks or part dislocation.		
	Change of temperature		-25°C to +70°C 100 cycles					
	Dry heat		960 hours at 85°C					
	Cold		960 hours at -25°C					
	Salt mist		48 hours in a 5% concentration of salt mist					

■ Materials

Part	Material
Simplex plug housing	Synthetic resin
Spring	Steel
Ferrule	Zirconia
Simplex adapter housing	Synthetic resin
Adapter metal fittings	Stainless steel or copper alloy (Nickel plating)
Simplified receptacle housing	Synthetic resin
Simplified plug	Zirconia
Backplane connector housing	Synthetic resin
Split sleeve	Zirconia or copper alloy
Dust cap	Synthetic resin

Function diagram

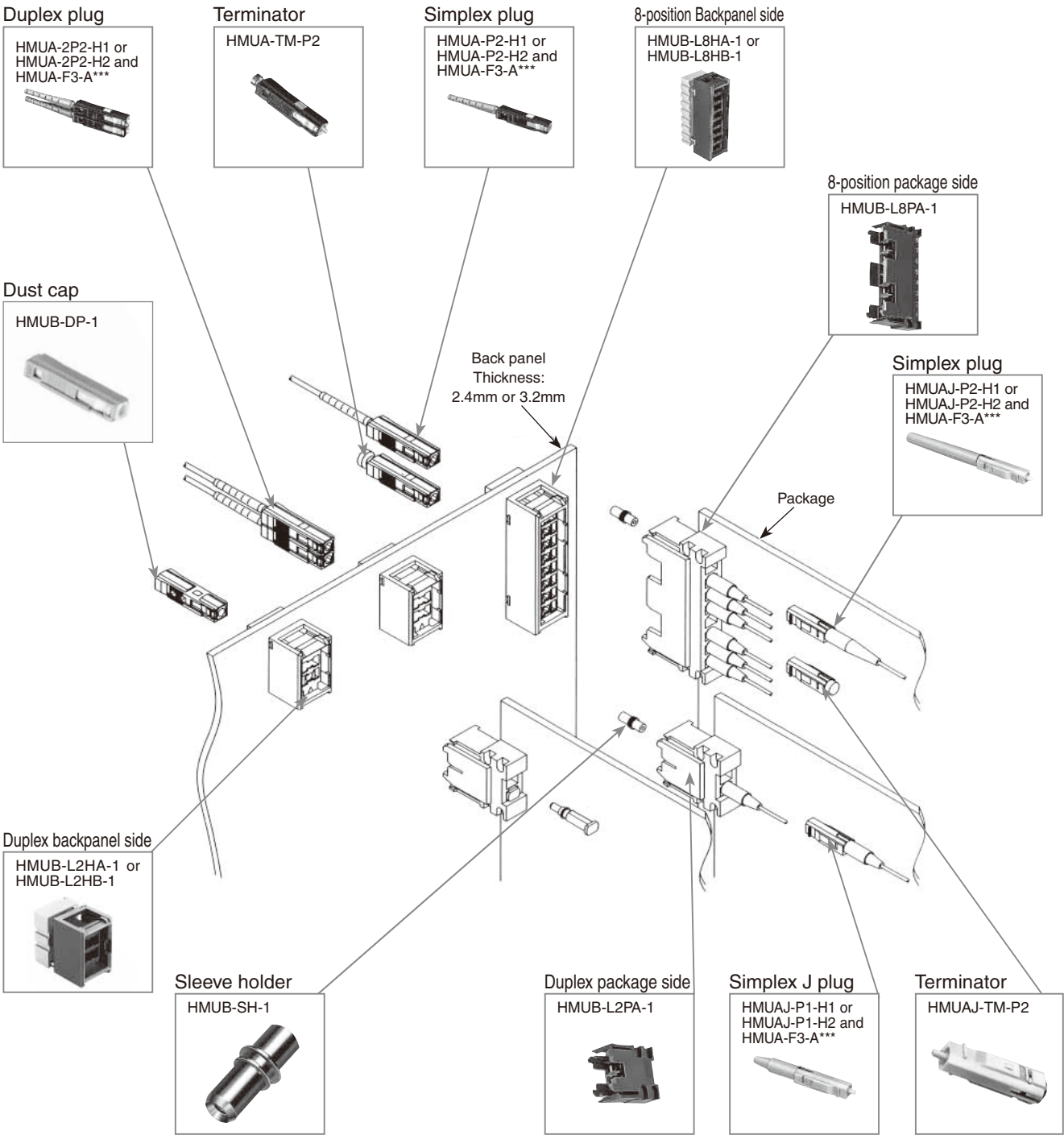

■ Ferrules

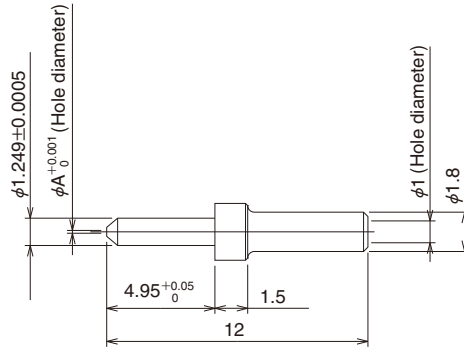
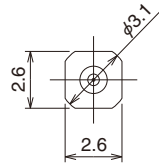
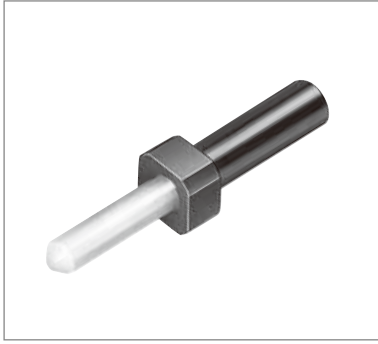

Part Number	CL No.	A dimension	Applicable Fiber cable
HMUA-F3-A125(10)	710-0024-3-10	0.125	SM-9.5/125 GI-50/125
HMUA-F3-A1255(10)	710-0121-0-10	0.1255	
HMUA-F3-A126(10)	710-0025-6-10	0.126	

SC

FC

MU

Harsh Environment

Attenuators

Terminators

POF / PCF

■ Plug Housings

● Simplex Plug Housing for 2mm cable

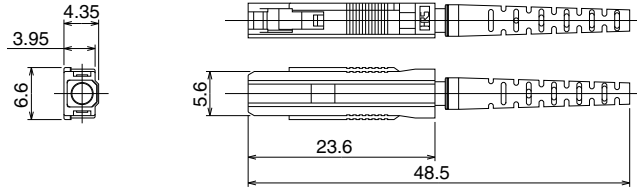

Part Number	CL No.	Boot color
HMUA-P2-H1(61)	710-0047-9-61	Blue
HMUA-P2-H2(61)	710-0001-8-61	Light purple

● Simplex Plug Housing for 0.9mm fiber

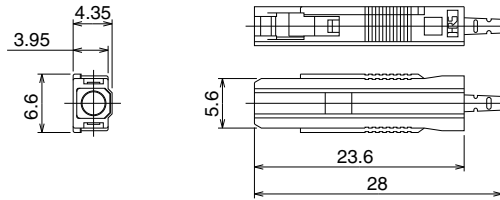

Part Number	CL No.	Boot color
HMUA-P0.9-H1(60)	710-0158-0-60	Blue
HMUA-P0.9-H2(60)	710-0159-2-60	Light purple

● Duplex Plug Housing for 2mm cable

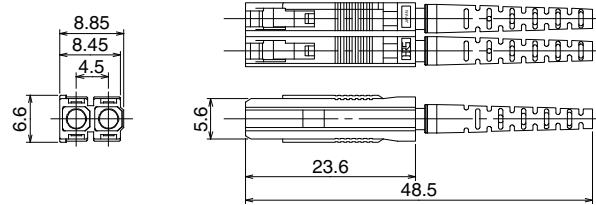

Part Number	CL No.	Boot color
HMUA-2P2-H1(61)	710-0048-1-61	Blue
HMUA-2P2-H2(61)	710-0002-0-61	Light purple

● Duplex Plug Housing for 0.9mm fiber

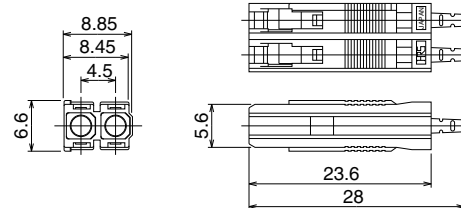

Part Number	CL No.	Boot color
HMUA-2P0.9-H1(60)	710-0162-7-60	Blue
HMUA-2P0.9-H2(60)	710-0163-0-60	Light purple

SC

FC

MU

Harsh Environment

Attenuators

Terminators

POF / PCF

● Simplex J Plug Housing for 0.9mm fiber

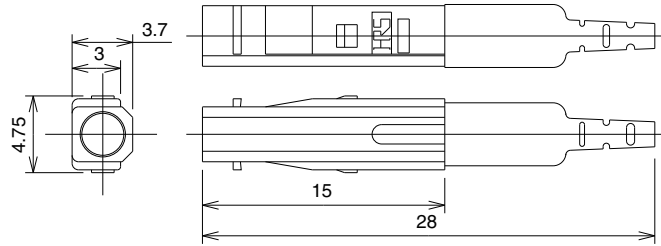

Part Number	CL No.	Boot color
HMUAJ-P0.9-H1(60)	710-0160-1-60	Blue
HMUAJ-P0.9-H2(60)	710-0161-4-60	Light purple

Notes : Option for this products
 Sleeve for temporary mating
 Part Number : HMUA-RH-1
 CL No. : CL710-0085-8
 Available to mate with standard adapter.
 (Usage example : Optical measurement)

Notes : This connector is the product for MU backplane solution, and is plugged into Package side Connector Housing with Sleeve Holder.
 But can't mate with standard MU adapter.

SC

FC

MU

Harsh Environment

Attenuators

Terminators

POF / PCF

Adapters

Simplex Adapter / Snap-in Panel Mounting

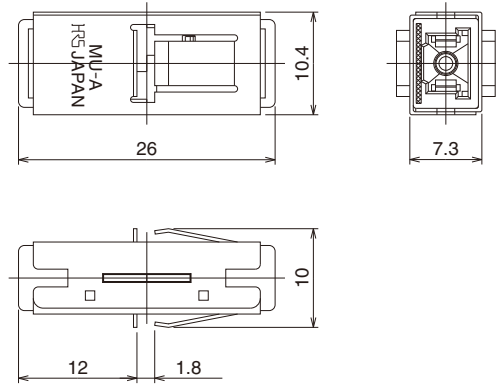

Panel Cutout

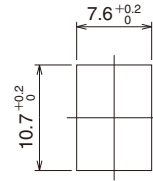

Panel thickness: 1.6mm

Part Number	CL No.	Split sleeve
HMUA-A-3	710-0103-8-00	Zirconia

Simplex Adapter / Screw Panel Mounting

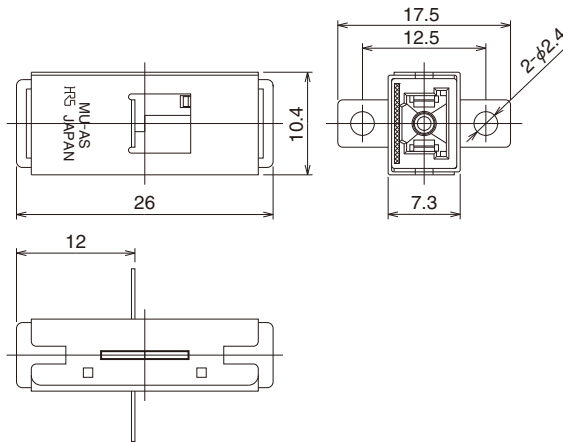

Panel Cutout

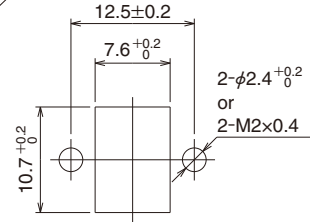

Part Number	CL No.	Split sleeve
HMUA-AS-3	710-0104-0-00	Zirconia

Simplex Adapter / Board Mounting

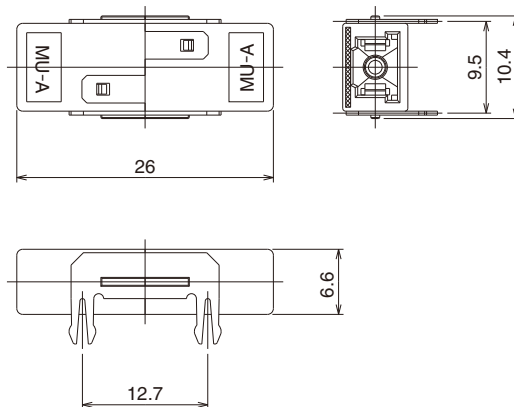

Board Mounting Pattern

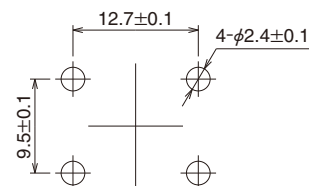

Board thickness: 1.6mm

Part Number	CL No.	Split sleeve
HMUA-AH-3(40)	710-0105-3-40	Zirconia

SC

FC

MU

Harsh Environment

Attenuators

Terminators

POF / PCF

● Duplex adapter / Snap-in Panel Mounting

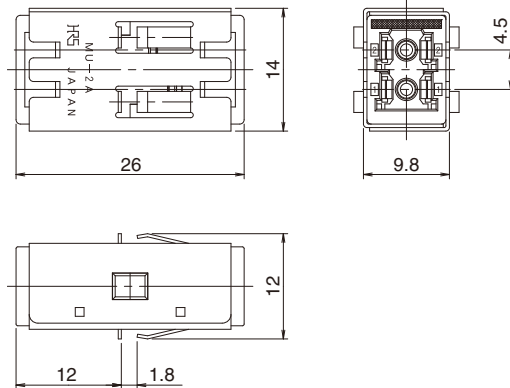

■ Panel Cutout

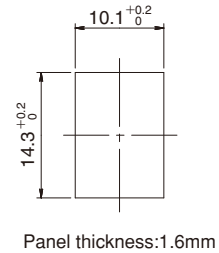

Part Number	CL No.	Split sleeve
HMUA-2A-4	710-0187-8-00	Zirconia

● Duplex Adapter / Screw Panel Mounting

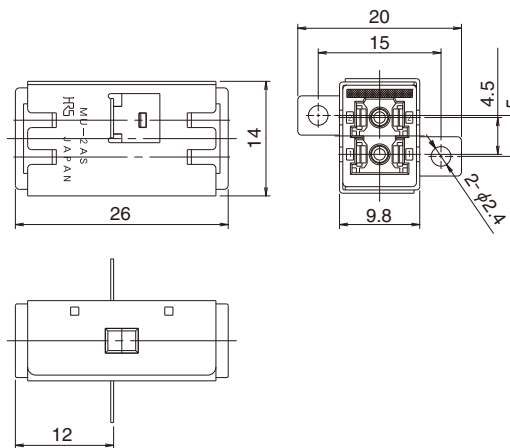

■ Panel Cutout

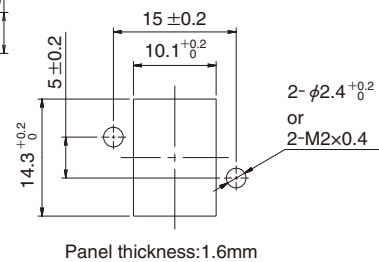

Part Number	CL No.	Split sleeve
HMUA-2AS-4	710-0188-0-00	Zirconia

● Duplex Adapter / Board Mounting

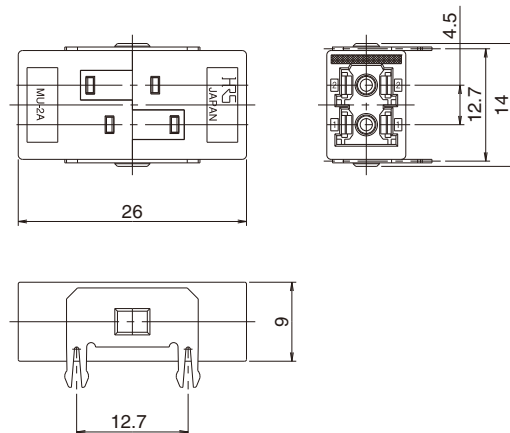

■ Board Mounting Pattern

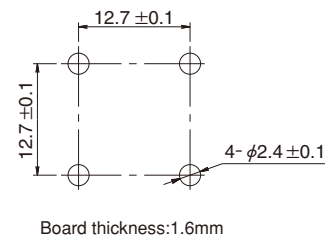

Part Number	CL No.	Split sleeve
HMUA-2AH-4(40)	710-0189-3-40	Zirconia

SC

FC

MU

Harsh Environment

Attenuators

Terminators

POF / PCF

● Duplex Adapter / Snap-in Panel Mounting
6.25mm Type

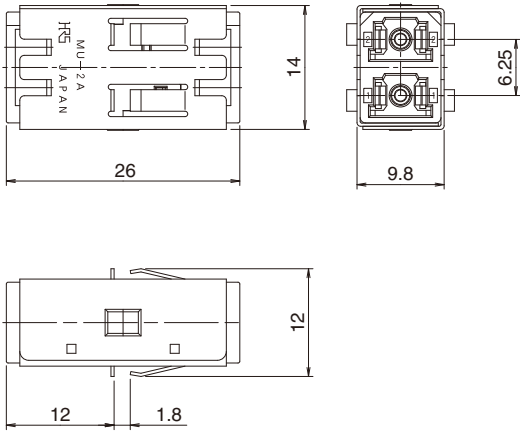
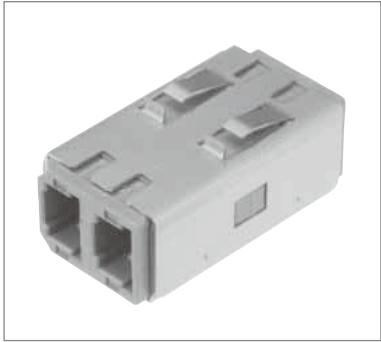

■ Panel Cutout

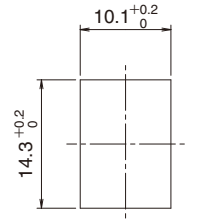

Board thickness: 1.6mm

Part Number	CL No.	Split sleeve
HMUA-2AK-1	710-0196-9-00	Zirconia

- Notes :
- Available to 6.25mm pitch MU-PJ attenuators.
 - The outer dimension (and panel cutout) is same as the above "HMUA-2A-4".

SC

FC

MU

Harsh Environment

Attenuators

Terminators

POF / PCF

●8-Position Adapter / Snap-in Panel Mounting

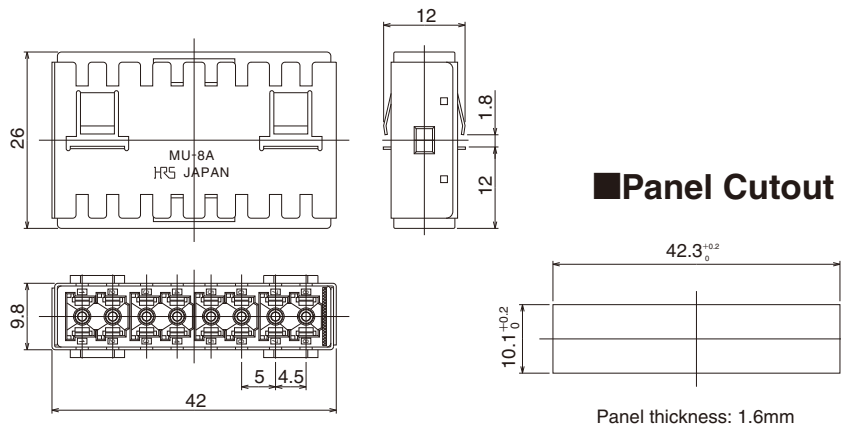

Part Number	CL No.	Split sleeve
HMUA-8A-3	710-0174-6-00	Zirconia

●8-Position Adapter / Screw Panel Mounting

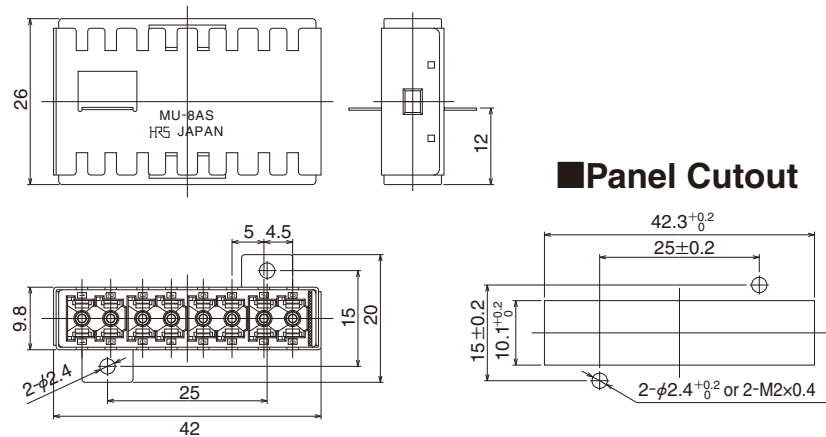

Part Number	CL No.	Split sleeve
HMUA-8AS-3	710-0175-9-00	Zirconia

●8-Position Adapter / Board Mounting

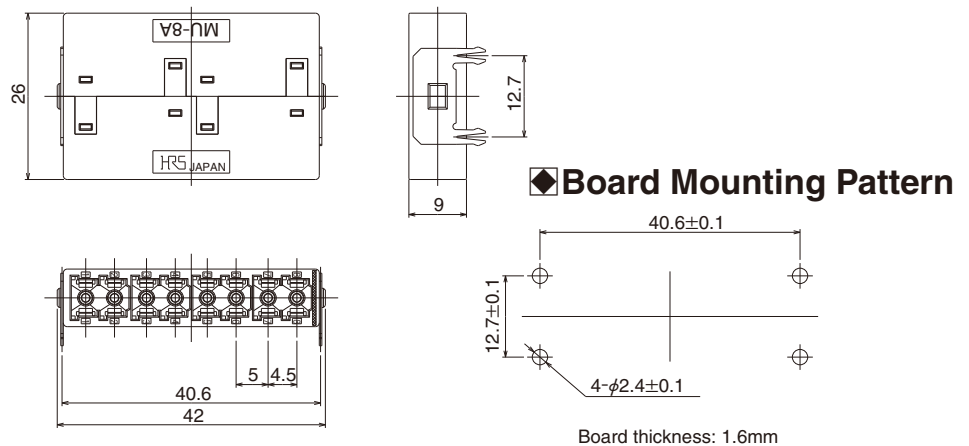

Part Number	CL No.	Split sleeve
HMUA-8AH-3(40)	710-0176-1-40	Zirconia

SC

FC

MU

Harsh Environment

Attenuators

Terminators

POF / PCF

■ Cost effective adapters

● 8-Position Adapter / Screw Panel Mounting

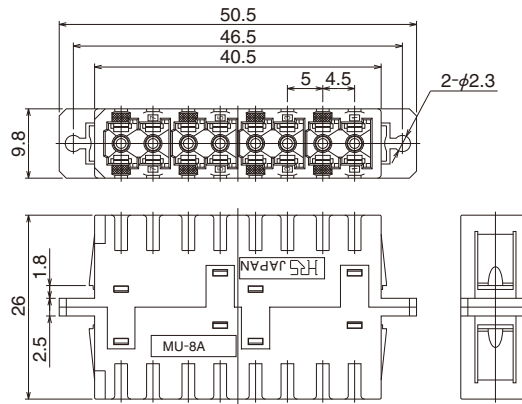
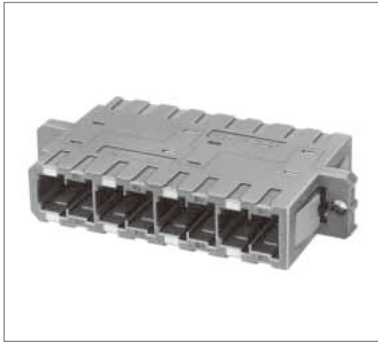

■ Panel Cutout

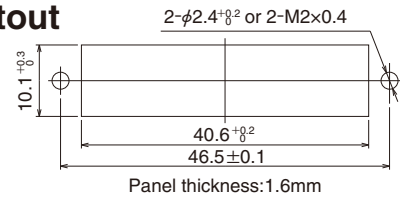

Part Number	CL No.	Split sleeve
HMUA-8A-2(40)	710-0155-1-40	Zirconia
HMUA-8A-B2	710-0119-8-00	Copper alloy

● 16-Position Adapter / Screw Panel Mounting

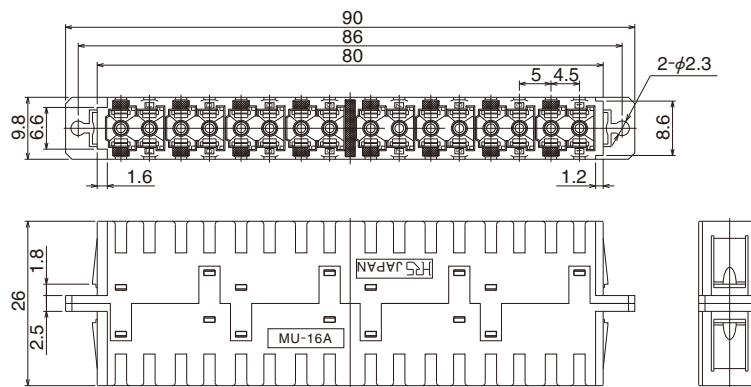

■ Panel Cutout

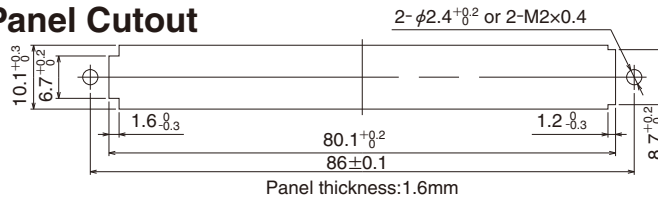

Part Number	CL No.	Split sleeve
HMUA-16A-2	710-0143-2-00	Zirconia
HMUA-16A-B2(40)	710-0113-1-40	Copper alloy

SC

FC

MU

Harsh Environment

Attenuators

Terminators

POF / PCF

■ Angled Adapters

Special design for angled mount. (The installation angle is 40 degrees.)

● Duplex Angled Adapter / Snap-in Panel Mounting

■ Panel Cutout

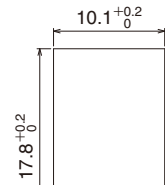
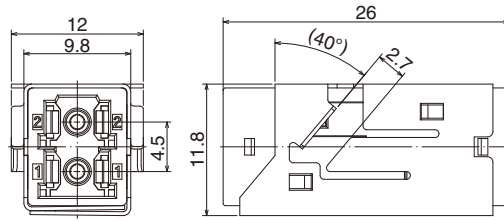

Panel thickness: 2.5mm

Part Number	CL No.	Split sleeve	Mounting Angle
HMUA-2A-40A-4	710-0243-7-00	Zirconia	40°

● 4-Position Angled Adapter / Snap-in Panel Mounting

■ Panel Cutout

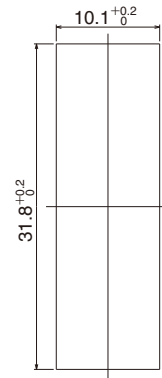
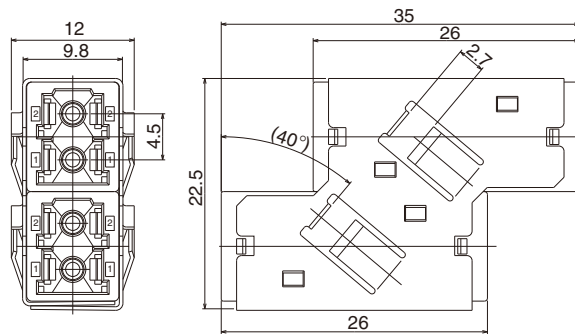

Panel thickness: 2.5mm

Part Number	CL No.	Split sleeve	Mounting Angle
HMUA-4A-40-4	710-0178-7-00	Zirconia	40°

SC

FC

MU

Harsh Environment

Attenuators

Terminators

POF / PCF

●Duplex Angled Adapter with Shutter / Snap-in Panel Mounting

■Panel Cutout

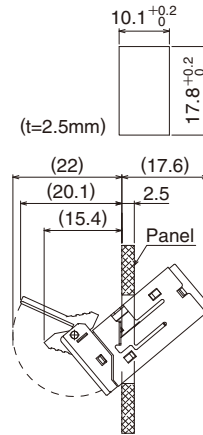
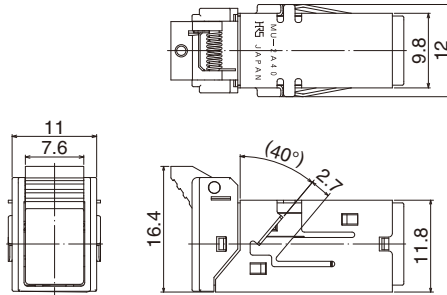

Part Number	CL No.	Split sleeve	Mounting Angle
HMUA-2A-40A-4-S1	710-0242-4-00	Zirconia	40°

Note:

- 1)Under no circumstances look into the inside of shutter when the laser device is operational. The laser radiation is not visible to the human eye, but it can seriously damage your eyesight.
- 2)Please indicate the necessary safety labels when using high power light source.

Panel Cutout dimensions

Only the angled adapter without shutter.

Fiber Position	Panel cutout:Xmm
06(Duplex+4 position)	47.4
08(4 position×2)	61.4
10(Duplex+4 position×2)	77.1
12(4 position×3)	91.0
14(Duplex+4 position×3)	106.7
16(4 position×4)	120.7
18(Duplex+4 position×4)	136.3
20(4 position×5)	150.3

■Panel Cutout

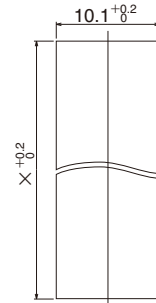

Panel thickness: 2.5mm

■Usage Example

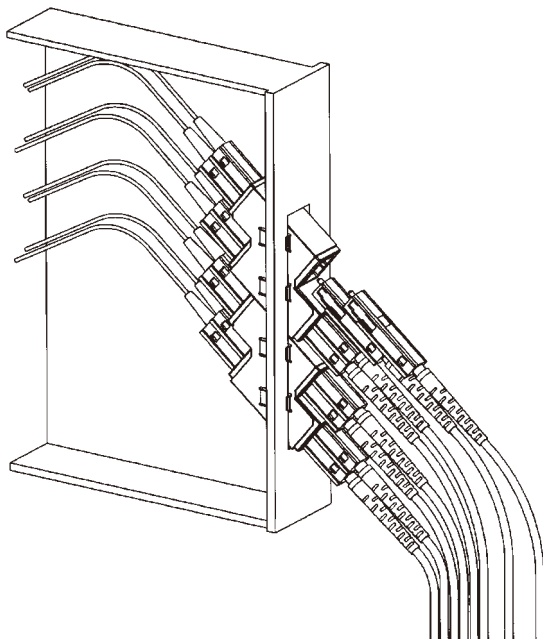

SC

FC

MU

Harsh Environment

Attenuators

Terminators

POF / PCF

SC

■ Backpanel side Connector Housings

● Duplex Backpanel side Connector Housing

■ Panel Cutout

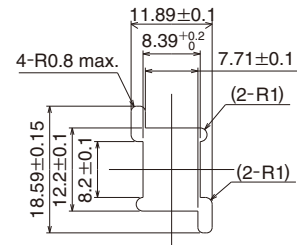
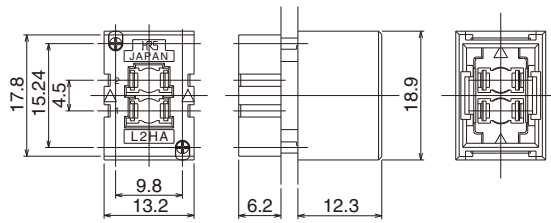
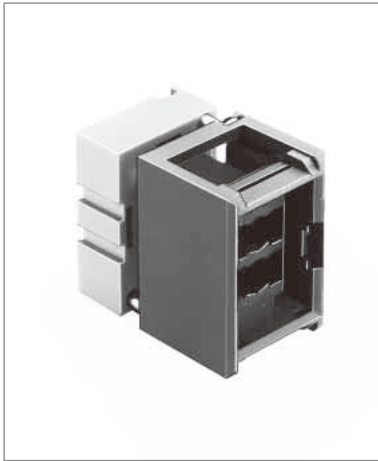

Part Number	CL No.	Panel thickness
HMUB-L2HA-1(40)	710-0017-8-40	2.4mm
HMUB-L2HB-1(40)	710-0018-0-40	3.2mm

Note: Screw fastening torque: 0.03Nm

FC

MU

● 8-Position Backpanel side Connector Housing

■ Panel Cutout

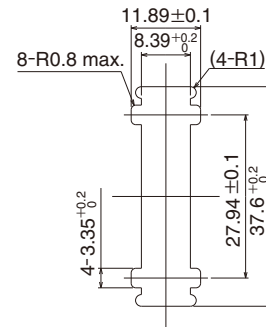
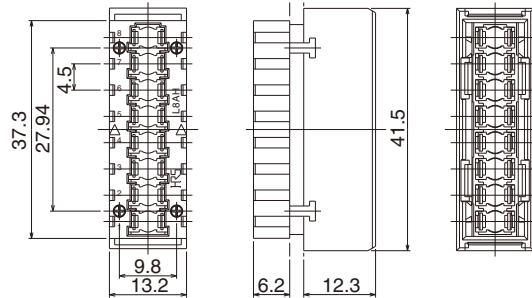

Part Number	CL No.	Panel thickness
HA-1(40)	710-0019-3-40	2.4mm
HMUB-L8HB-1(40)	710-0020-2-40	3.2mm

Note: Screw fastening torque: 0.03Nm

Harsh Environment

Attenuators

Terminators

POF / PCF

■ Package side Connector Housings

● Duplex Package side Connector Housing

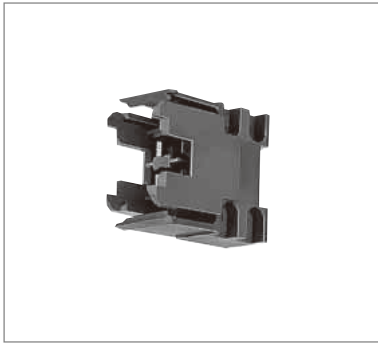

Part Number	CL No.
HMUB-L2PA-1(40)	710-0015-2-40

Note : Screw fastening torque : 0.15Nm

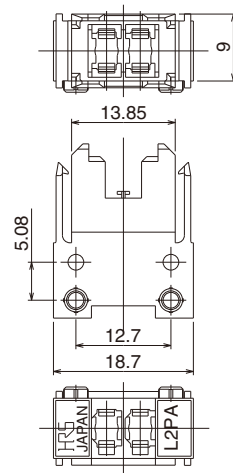

■ Board Mounting Pattern

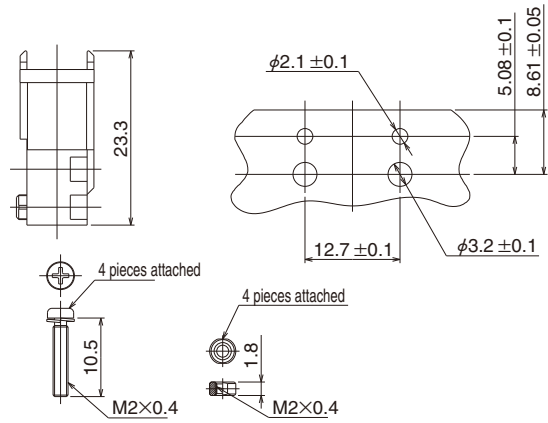

● 8-Position Package side Connector Housing

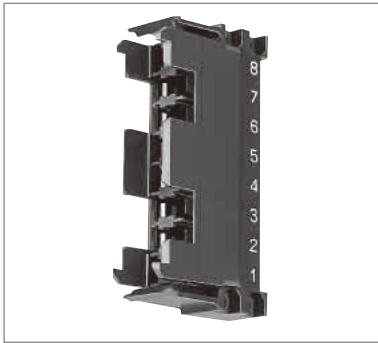

Part Number	CL No.
HMUB-L8PA-1(40)	710-0016-5-40

Note : Screw fastening torque : 0.15Nm

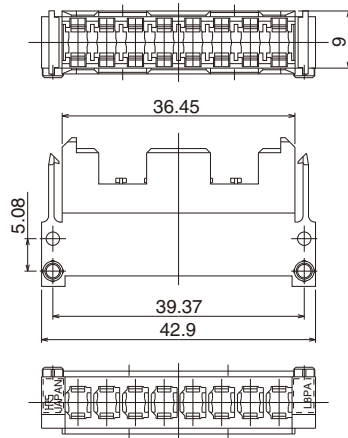

■ Board Mounting Pattern

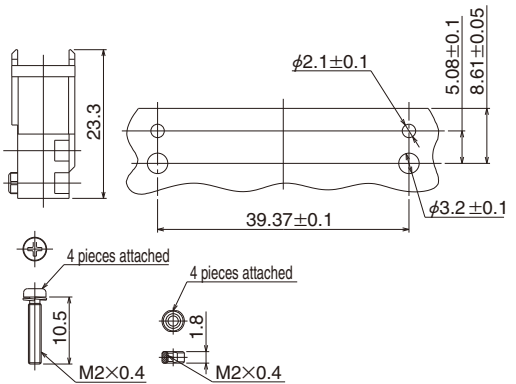

■ Sleeve Holder

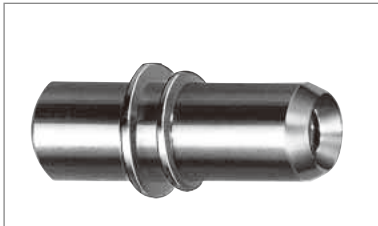

Part Number	CL No.	Split sleeve
HMUB-SH-1(40)	710-0021-5-40	Zirconia

Note: This Sleeve Holder should be used for duplex and 8-position package side connector housing and J Plug Housing connector plug.

Insert the Sleeve Holder using dedicated tool #HMUB-TS-1.

The gold plated section of the Sleeve Holder should be inserted into the package side connector housing.

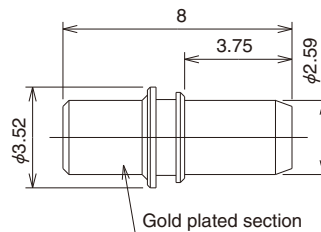

■ Simplified Receptacles

● Simplex Simplified Receptacle / Screw Panel Mounting

■ Panel Cutout

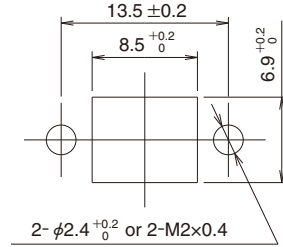
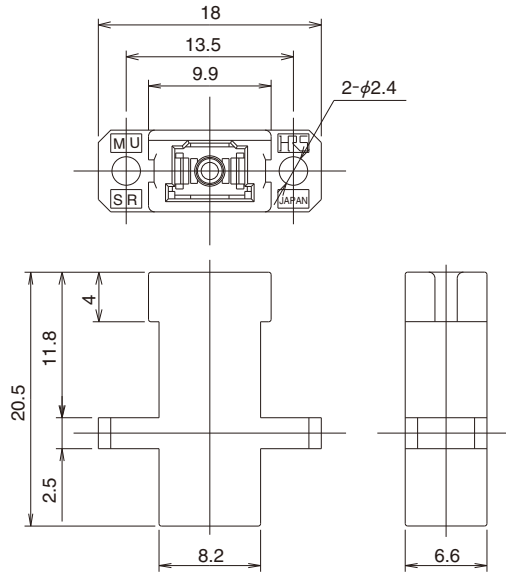

Part Number	CL No.	Split sleeve
HMUA-SR-1(40)	710-0094-9-40	Zirconia
HMUA-SR-B1	710-0182-4-00	Copper alloy

● 10-position Simplified Receptacle / Screw Panel Mounting

■ Panel Cutout

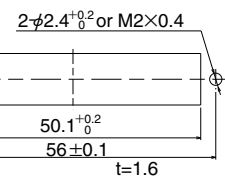
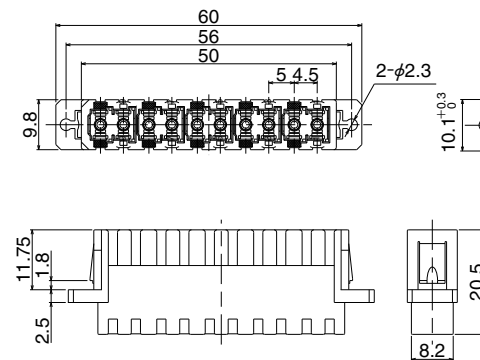

Part Number	CL No.	Split sleeve
HMUA-10SR-4	710-0193-0-00	Zirconia
HMUA-10SR-B4	710-0201-7-00	Copper alloy

SC

FC

MU

Harsh Environment

Attenuators

Terminators

POF / PCF

●8-position Simplified Receptacle - for extremely high density applications

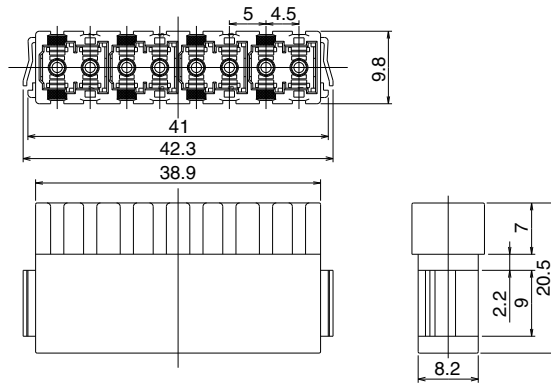

Part Number	CL No.	Split sleeve
HMUA-8SR-3(40)	710-0168-3-40	Zirconia
HMUA-8SR-B3(40)	710-0117-2-40	Copper alloy

Please contact to HIROSE for the mounting dimension.

●16-Position Simplified Receptacle - for extremely high density applications

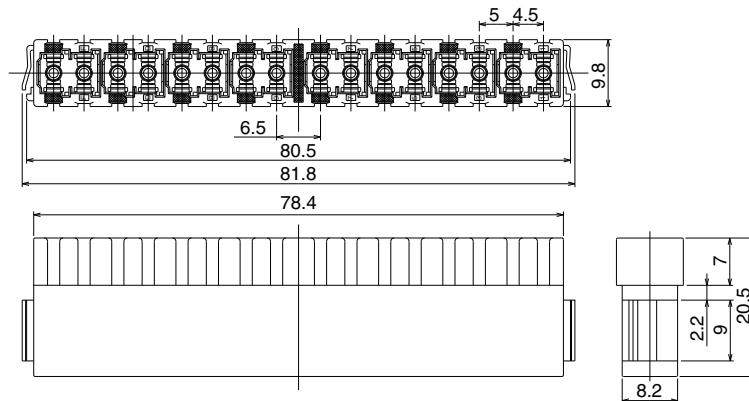
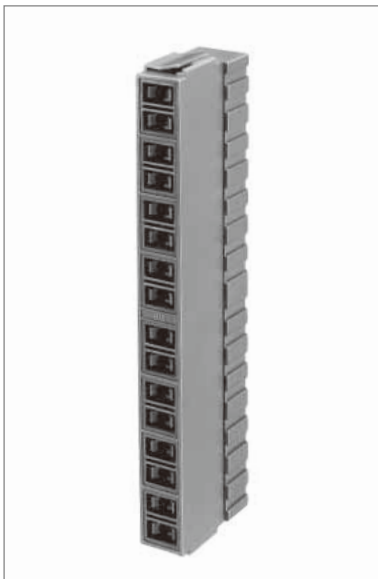

Part Number	CL No.	Split sleeve
HMUA-16SR-5	710-0173-3-00	Zirconia
HMUA-16SR-B5	710-0122-2-00	Copper alloy

Please contact to HIROSE for the mounting dimension.

■Mounting Example

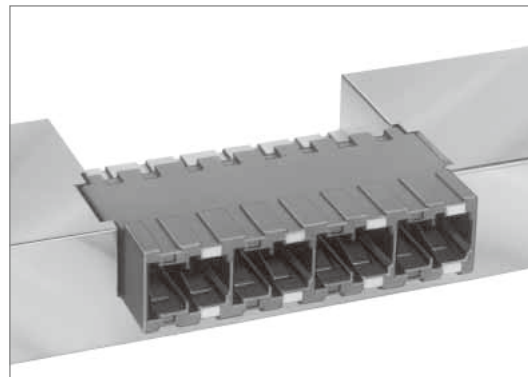
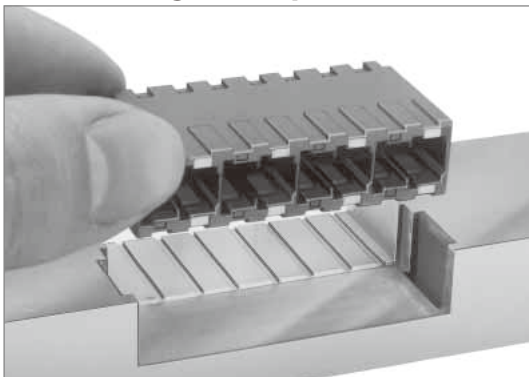

SC

FC

MU

Harsh Environment

Attenuators

Terminators

POF / PCF

■ Simplified Plug

● Simplex simplified Plug for 0.9mm fiber

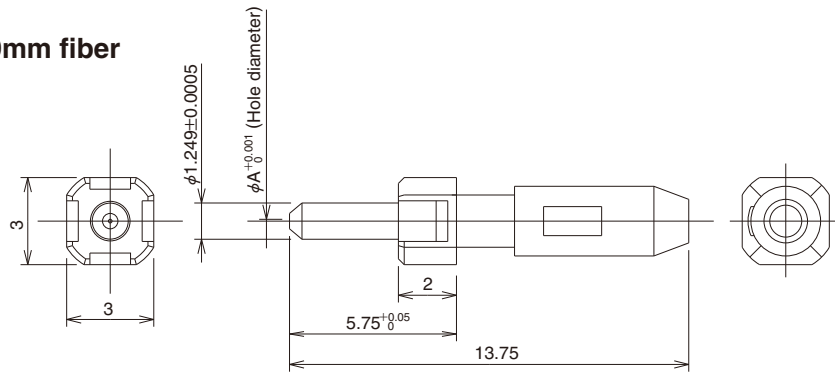

Part Number	CL No.	A dimension	Applicable Fiber cable	Ferrule
HMUA-FK-A125(04)	710-0099-2-04	0.125	SM-9.5/125 GI-50/125	Zirconia
HMUA-FK-A1255(04)	710-0107-9-04	0.1255		
HMUA-FK-A126(04)	710-0100-0-04	0.126		

■ Split Sleeve

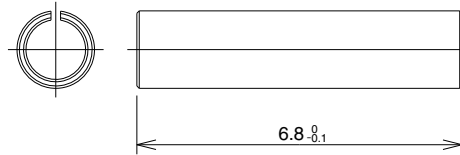
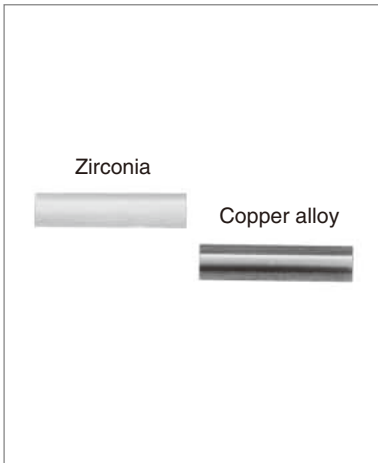

Part Number	CL No.	Split sleeve
HMUA-D	710-0147-3-00	Zirconia
HMUA-SLIT-SLEEVE(01)	710-0130-0-01	Copper alloy

■ Extraction Tool for Simplified Plug

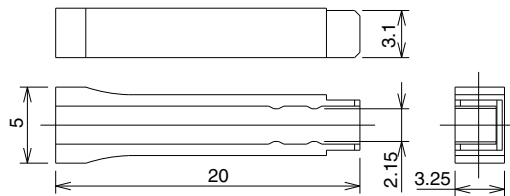

Part Number	CL No.
HMUA-FK-T3	710-0148-6-00

■ Dust Caps

● Dust Cap for Backpanel side connector housings

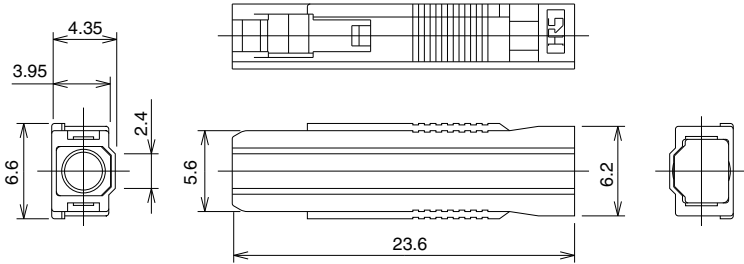

Part Number	CL No.	Applicable connector
HMUB-DP-1(40)	710-0135-4-40	Back panel side housing

● Dust Cap for Adapters

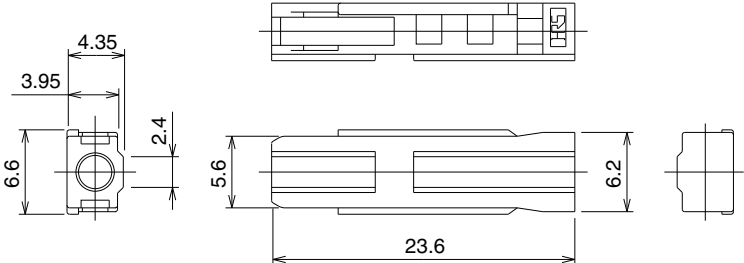

Part Number	CL No.	Applicable connector
HMUA-DP-2	710-0131-3-00	Adapter, simplified receptacle

- SC
- FC
- MU
- Harsh Environment
- Attenuators
- Terminators
- POF / PCF

Tools

● Insertion / Extraction Tool for Plug



Part Number	CL No.	Color of Tip	Remarks
HMUA-TP-1	710-0074-1	Blue	For Conventional Adapters
HMUB-TP-1	710-0075-4	Brown	For MU Backplane system

● Insertion / Extraction Tool for Plug Cost effective type



Part Number	CL No.	Remarks
HMU/HEMD-1P	902-6045-8	For Conventional Adapters and MU Backplane system

● Extraction Tool for J Plug



Part Number	CL No.	Remarks
HMUB-TJ-1	710-0076-7	HMUB-L2PA-1, L8PA-1

● Insertion / Extraction Tool for Sleeve Holder



Part Number	CL No.	Remarks
HMUB-TS-1	710-0077-0	HMUB-L2PA-1, L8PA-1

SC

FC

MU

Harsh Environment

Attenuators

Terminators

POF / PCF

●Crimp Tools



Part Number	CL No.	Applicable plug housing
HT402/HMUA-P2-H2	902-6040-4	HMUA-P2-H2,H1
		HMUA-2P2-H2,H1

●Stop Ring Insertion Tool



Part Number	CL No.	Applicable connector
HMUA.J/PRMD	902-6019-8	MU plug housings except HMUA-P1.1-H2

Компания «Life Electronics» занимается поставками электронных компонентов импортного и отечественного производства от производителей и со складов крупных дистрибьюторов Европы, Америки и Азии.

С конца 2013 года компания активно расширяет линейку поставок компонентов по направлению коаксиальный кабель, кварцевые генераторы и конденсаторы (керамические, пленочные, электролитические), за счёт заключения дистрибьюторских договоров

Мы предлагаем:

- Конкуренеспособные цены и скидки постоянным клиентам.
- Специальные условия для постоянных клиентов.
- Подбор аналогов.
- Поставку компонентов в любых объемах, удовлетворяющих вашим потребностям.
- Приемлемые сроки поставки, возможна ускоренная поставка.
- Доставку товара в любую точку России и стран СНГ.
- Комплексную поставку.
- Работу по проектам и поставку образцов.
- Формирование склада под заказчика.
- Сертификаты соответствия на поставляемую продукцию (по желанию клиента).
- Тестирование поставляемой продукции.
- Поставку компонентов, требующих военную и космическую приемку.
- Входной контроль качества.
- Наличие сертификата ISO.

В составе нашей компании организован Конструкторский отдел, призванный помогать разработчикам, и инженерам.

Конструкторский отдел помогает осуществить:

- Регистрацию проекта у производителя компонентов.
- Техническую поддержку проекта.
- Защиту от снятия компонента с производства.
- Оценку стоимости проекта по компонентам.
- Изготовление тестовой платы монтаж и пусконаладочные работы.



Тел: +7 (812) 336 43 04 (многоканальный)

Email: org@lifeelectronics.ru