

Low-Power Single/Dual-Supply Dual Comparator with Reference

FEATURES

- Single or Dual Power Supplies:
Single: +2.5V to +11V
Dual: $\pm 1.25V$ to $\pm 5.5V$
- Internal $1.182V \pm 0.75\%$ Reference
- Fully Assembled and Tested
- Push-pull TTL/CMOS-Compatible Outputs
- 2in x 2in 2-layer circuit board

DESIGNATION	QTY	DESCRIPTION
C1	1	0.1 μ F $\pm 10\%$ capacitors (0805)
R1	1	20k $\Omega \pm 1\%$ resistor (0805)
R2	1	2.4M $\Omega \pm 1\%$ resistor (0805)
U1	1	TS9002 Comparator
INA+, INB-, HYST, VDD, OUT_B, OUT_A, REF, GND (7)	14	Test points

Table 1. Component List

DESCRIPTION

The demo board for the TS9002 is a completely assembled and tested circuit board that can be used for evaluating the TS9002. The TS9002 joins Touchstone's TS9001-1/2 analog comparators in the "NanoWatt Analog™" high performance analog integrated circuits portfolio. The TS9002 can operate from single +2.5V to +11V supplies or from $\pm 1.25V$ to $\pm 5.5V$ dual supplies.

The TS9002 incorporates an internal $1.182V \pm 0.75\%$ voltage reference. Without complicated feedback configurations and only requiring two additional resistors, adding external hysteresis via a separate pin is available on the TS9002's HYST pin.

The TS9002 is fully specified over the $-40^{\circ}C$ to $+85^{\circ}C$ temperature range and is available in a 8-pin MSOP package.

Product data sheets and additional documentation can be found on factory web site at www.touchstonesemi.com.

ORDERING INFORMATION

Order Number	Description
TS9002DB	Demo Board

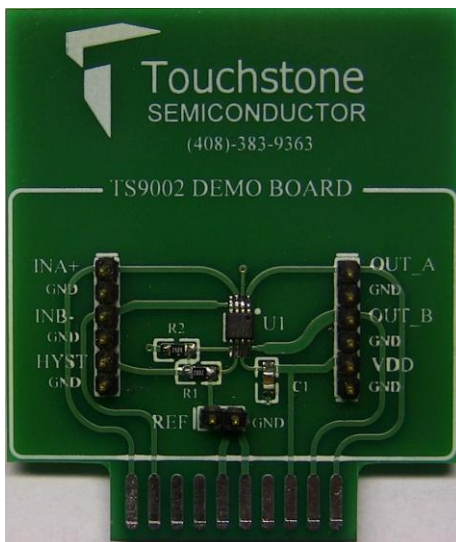

Figure 1. TS9002 Evaluation Board (Top View)



Figure 2. TS9002 Evaluation Board (Bottom View)

DESCRIPTION

The demo board provides a configuration where only two resistors are required to set the hysteresis band, V_{HB} , as shown in Figure 3. Resistor R1 is connected between REF and HYST and R2 is connected between HYST and V-. This will increase the trip point for the rising input voltage, V_{THR} , and decrease the trip point for the falling input voltage, V_{THF} , by the same amount. If no hysteresis is required, connect HYST to REF. The hysteresis band, V_{HB} , is voltage across the REF and HYST pin multiplied by a factor of 2. The HYST pin can accept a voltage between REF and REF-50mV, where a voltage of REF-50mV generates the maximum voltage across R1 and thus, the maximum hysteresis and hysteresis band of 50mV and 100mV, respectively. On the board, V-(pin 2) is labeled as GND.

To design the circuit for a desired hysteresis band, consider the equations below to acquire the values for resistors R1 and R2:

$$R1 = \frac{V_{HB}}{(2 \times I_{REF})}$$

$$R2 = \frac{1.182 - \frac{V_{HB}}{2}}{I_{REF}}$$

The TS9002 demo board provides $R1 = 20k\Omega$ and $R2 = 2.4M\Omega$. This sets the hysteresis band to $V_{HB} = 20mV$.

QUICK START PROCEDURES

Required Equipment

- TS9002DB demo board
- A DC Power Supply, an HP Model HP6624A or equivalent
- A Precision DC Source/Calibrator, a Krohn-Hite Model 526 or equivalent
- A Digital Voltmeter
- A Digital Ammeter
- Oscilloscope Model Agilent DSO1014A or equivalent (AC input only)
- 1M Ω oscilloscope probe (AC input only)

- Function Generator (AC test only)

To evaluate the TS9002 comparators, the following steps are to be performed:

- 1) Before connecting the DC power supply to the demo board power test points, turn on the power supply and set the DC voltage to 5V and then turn it off.
- 2) Set the DC source/calibrator voltage to 1.182V and turn it off.
- 3) Connect the positive terminal of the DC power supply to the V_{DD} jumper on the demo board and the negative terminal to the positive terminal of the ammeter. Then, connect the negative terminal of the ammeter to a GND jumper on the demo board.
- 4) Connect the positive terminal of the DC source/calibrator to the INA+ jumper on the demo board and the negative terminal to a GND jumper on the demo board.
- 5) Connect the positive terminal of the DC voltmeter to the OUT_A jumper on the demo board and the negative terminal to a GND jumper on the demo board.
- 6) Turn on the power supply and the DC source/calibrator and check that the power supply current is approximately 3 μ A.
- 7) Slowly increase the DC source/calibrator voltage until the output of the comparator switches to approximately 5V. Refer to the voltmeter. The output should switch from a low state to a high state at approximately 1.192V. The power supply current is now approximately 3.6 μ A
- 8) Now, slowly decrease the DC source/calibrator voltage until the output of the comparator drops to approximately 0V. Refer to the voltmeter. The output should switch from a high state to a low state at approximately 1.172V. The power supply current is approximately 3 μ A.
- 9) To check the HYST pin voltage or the reference voltage, connect the positive terminal of a voltmeter to the HYST or REF jumper on the demo board and the negative terminal to a GND jumper on the demo board.

10) If testing with an AC input signal is desired, use a function generator and set the offset voltage, amplitude, and frequency to 1.182V, 100mV, and 1kHz, respectively. Connect the positive terminal of the function generator to the INA+ jumper and the negative terminal to the GND jumper on the board.

Then, use the oscilloscope and the oscilloscope probe to monitor the output OUT_A.

11) If the evaluation of comparator B is desired, follow the previous steps. However, note that the output signal OUT_B is the inverted version comparator A's output OUT_A.

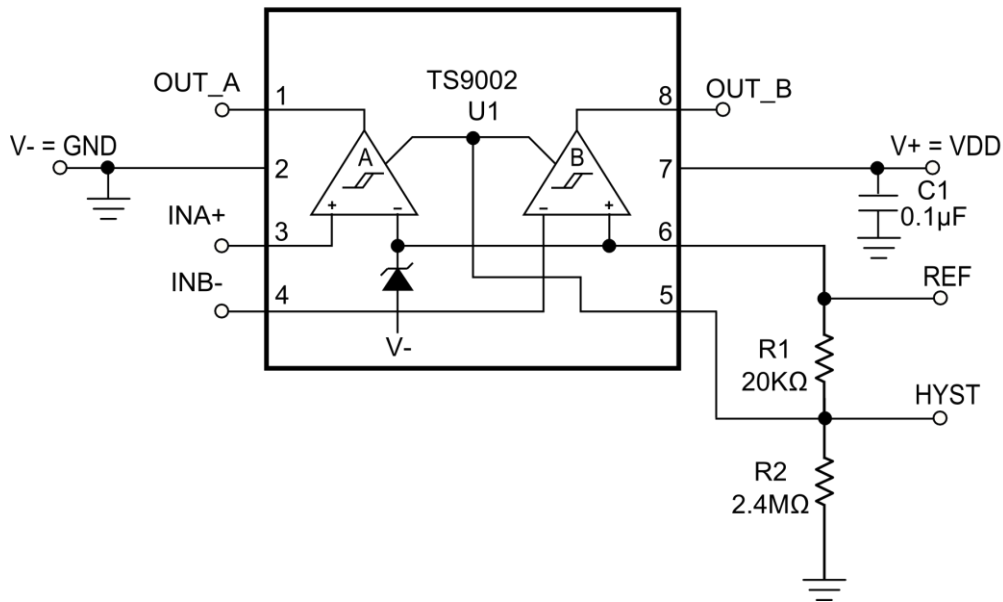

Figure 3. TS9002 Demo Board Circuit

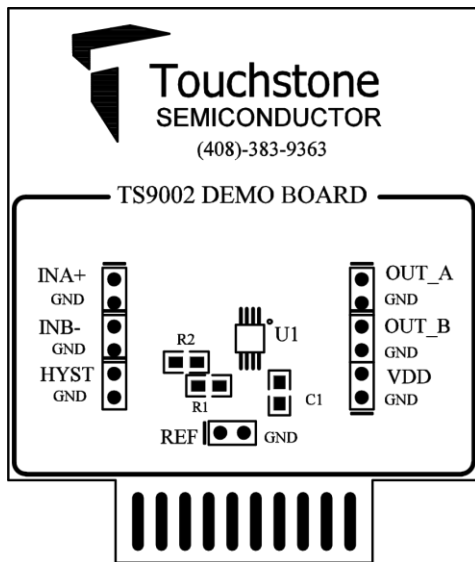

Figure 4. Top Layer Component View

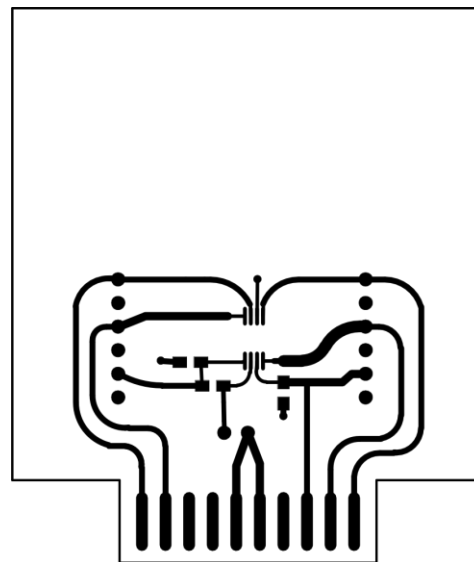

Figure 5. Top Layer Trace View

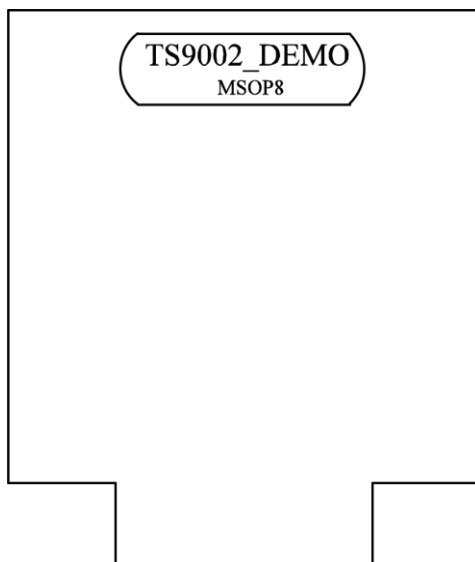

Figure 6. Bottom Layer #1

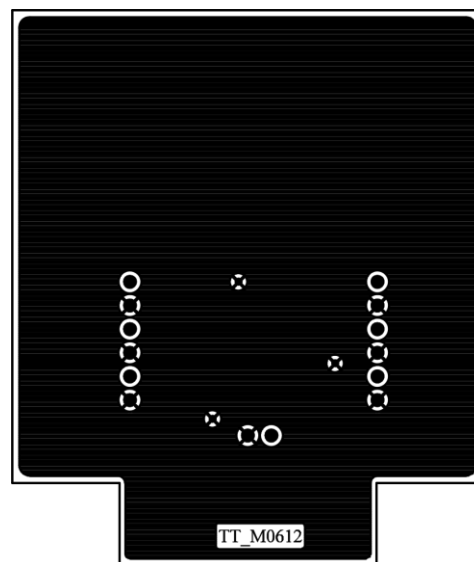

Figure 7. Bottom Layer #2

Компания «Life Electronics» занимается поставками электронных компонентов импортного и отечественного производства от производителей и со складов крупных дистрибьюторов Европы, Америки и Азии.

С конца 2013 года компания активно расширяет линейку поставок компонентов по направлению коаксиальный кабель, кварцевые генераторы и конденсаторы (керамические, пленочные, электролитические), за счёт заключения дистрибьюторских договоров

Мы предлагаем:

- Конкуренспособные цены и скидки постоянным клиентам.
- Специальные условия для постоянных клиентов.
- Подбор аналогов.
- Поставку компонентов в любых объемах, удовлетворяющих вашим потребностям.
- Приемлемые сроки поставки, возможна ускоренная поставка.
- Доставку товара в любую точку России и стран СНГ.
- Комплексную поставку.
- Работу по проектам и поставку образцов.
- Формирование склада под заказчика.
- Сертификаты соответствия на поставляемую продукцию (по желанию клиента).
- Тестирование поставляемой продукции.
- Поставку компонентов, требующих военную и космическую приемку.
- Входной контроль качества.
- Наличие сертификата ISO.

В составе нашей компании организован Конструкторский отдел, призванный помогать разработчикам, и инженерам.

Конструкторский отдел помогает осуществить:

- Регистрацию проекта у производителя компонентов.
- Техническую поддержку проекта.
- Защиту от снятия компонента с производства.
- Оценку стоимости проекта по компонентам.
- Изготовление тестовой платы монтаж и пусконаладочные работы.



Тел: +7 (812) 336 43 04 (многоканальный)

Email: org@lifeelectronics.ru