

I²C Digital Input RTC with Alarm

DS1375

General Description

The DS1375 digital real-time clock (RTC) is a low-power clock/calendar that does not require a crystal. The device operates from a digital clock input pin at one of four frequencies: 32.768kHz, 8.192kHz, 60Hz, or 50Hz. It maintains seconds, minutes, hours, day, date, month, and year information. The date at the end of the month is automatically adjusted for months with fewer than 31 days, including corrections for leap year. The clock operates in either the 24-hour or 12-hour format with an AM/PM indicator. Two programmable time-of-day/date alarms, a programmable square-wave output, and 16 bytes of SRAM are provided. Address and data are transferred serially through an I²C bidirectional bus.

Applications

- RTC Complement to the DS32kHz TCXO
- Utility Meters
- Appliances
- Consumer Electronics
- Automotive

Features

- ◆ RTC Counts Seconds, Minutes, Hours, Day, Date, Month, and Year with Leap-Year Compensation Valid Up to 2100
- ◆ Two Programmable Alarms
- ◆ Programmable Square-Wave Output
- ◆ Operates from a 32.768kHz, 8.192kHz, 60Hz, or 50Hz Digital Clock Signal
- ◆ 16 Bytes of SRAM
- ◆ Fast (400kHz) I²C Interface
- ◆ 1.7V to 5.5V Operation

Ordering Information

PART	TEMP RANGE	PIN-PACKAGE	TOP MARK
DS1375T+	-40°C to +85°C	6 TDFN-EP*	DS1375

+ Denotes a lead-free/RoHS-compliant package.
*EP = Exposed pad.

Typical Operating Circuit

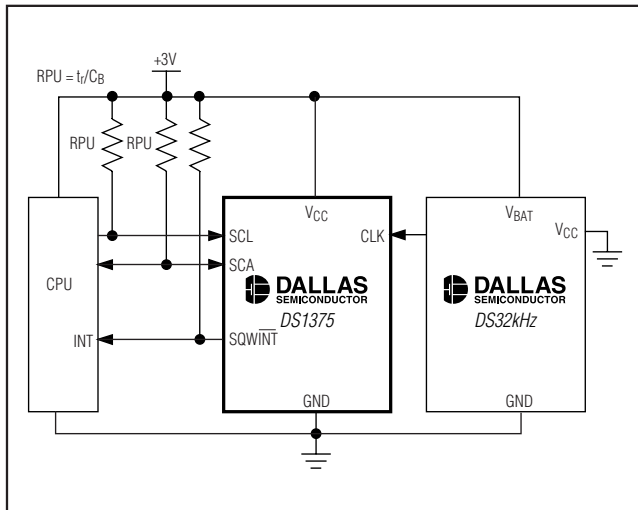

Pin Configuration

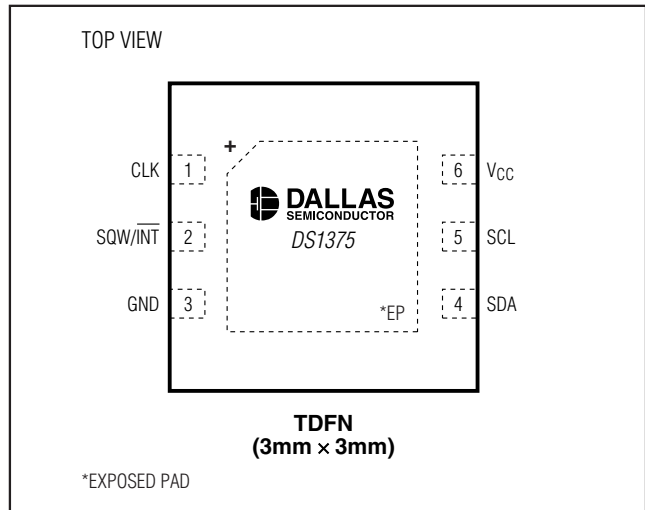

I²C Digital Input RTC with Alarm

ABSOLUTE MAXIMUM RATINGS

Voltage Range on V _{CC} Pin Relative to Ground.....	-0.3V to +6.0V	Storage Temperature Range	-55°C to +125°C
Voltage Range on SDA, SCL, and WDS Relative to Ground.....	-0.3V to V _{CC} + 0.3V	Soldering Temperature.....	Refer to the IPC/JEDEC J-STD-020 Specification.
Operating Temperature Range	-40°C to +85°C		

Stresses beyond those listed under "Absolute Maximum Ratings" may cause permanent damage to the device. These are stress ratings only, and functional operation of the device at these or any other conditions beyond those indicated in the operational sections of the specifications is not implied. Exposure to absolute maximum rating conditions for extended periods may affect device reliability.

RECOMMENDED DC OPERATING CONDITIONS

(V_{CC} = +1.7V to +5.5V, T_A = -40°C to +85°C, unless otherwise noted. Typical values are at V_{CC} = 3.3V, T_A = +25°C, unless otherwise noted.) (Note 1)

PARAMETER	SYMBOL	CONDITIONS	MIN	TYP	MAX	UNITS
Supply Voltage	V _{CC}	(Note 2)	1.7	3.3	5.5	V
Timekeeping Voltage	V _{TK}	(Note 2)	1.3		5.5	V
Input Logic 1 (SDA, SCL)	V _{IH}	(Note 2)	0.7 x V _{CC}		V _{CC} + 0.3	V
Supply Voltage, Pullup (SQW/ $\overline{\text{INT}}$, CLK)	V _{PULLUP}	(Notes 2, 3)			5.5	V
Input Logic 0	V _{IL}	(Notes 2, 4)	-0.3		+0.3 V _{CC}	V
Input Leakage (SCL, CLK)	I _{LI}		-1		+1	μA
I/O Leakage (SDA, SQW/ $\overline{\text{INT}}$)	I _{LO}		-1		+1	μA
SDA Logic 0 Output	I _{OLSDA}	V _{CC} > 2V; V _{OL} = 0.4V V _{CC} < 2V; V _{OL} = 0.2 x V _{CC}			3.0	mA
SQW/ $\overline{\text{INT}}$ Logic 0 Output	I _{OLSQW}	V _{CC} > 2V; V _{OL} = 0.4V 1.7V < V _{CC} < 2V; V _{OL} = 0.2 x V _{CC} 1.3V < V _{CC} < 1.7V; V _{OL} = 0.2 x V _{CC}			3.0 250	mA μA
Active Supply Current	I _{CCA}	(Notes 5, 6)		33	150	μA
Standby Current	I _{CCS}	(Notes 6, 7)		150	500	nA

Note 1: Limits at -40°C are guaranteed by design and not production tested.

Note 2: All voltages are referenced to ground.

Note 3: For the CLK pin, input voltages above V_{CC} + 0.3V cause current to flow into the device. The input current must not exceed the current drawn by the circuit that is connected to V_{CC}. Otherwise, current flows out of the DS1375, raising the voltage level on the V_{CC} bus.

Note 4: V_{IL MIN} on the CLK pin can exceed -0.3V as long as the current is limited to less than 1mA.

Note 5: I_{CCA}—SCL clocking at max frequency = 400kHz.

Note 6: CLK pin running at 32,768Hz, rise and fall times at 10ns or less.

Note 7: Specified with I²C bus inactive.

I²C Digital Input RTC with Alarm

AC ELECTRICAL CHARACTERISTICS

($V_{CC} = V_{CCMIN}$ to V_{CCMAX} , $T_A = -40^{\circ}\text{C}$ to $+85^{\circ}\text{C}$, unless otherwise noted.) (Note 1, Figure 1)

PARAMETER	SYMBOL	CONDITIONS	MIN	TYP	MAX	UNITS
SCL Clock Frequency	f _{SCL}	Fast mode	100		400	kHz
		Standard mode	0		100	
Bus Free Time Between STOP and START Conditions	t _{BUF}	Fast mode	1.3			μs
		Standard mode	4.7			
Hold Time (Repeated) START Condition (Note 8)	t _{HD:STA}	Fast mode	0.6			μs
		Standard mode	4.0			
Low Period of SCL Clock	t _{LOW}	Fast mode	1.3			μs
		Standard mode	4.7			
High Period of SCL Clock	t _{HIGH}	Fast mode	0.6			μs
		Standard mode	4.0			
Data Hold Time (Notes 9, 10)	t _{HD:DAT}	Fast mode	0		0.9	μs
		Standard mode	0		0.9	
Data Setup Time (Note 11)	t _{SU:DAT}	Fast mode	100			ns
		Standard mode	250			
Start Setup Time	t _{SU:STA}	Fast mode	0.6			μs
		Standard mode	4.7			
Rise Time of Both SDA and SCL Signals (Note 12)	t _R	Fast mode	20 + 0.1C _B		300	ns
		Standard mode			1000	
Fall Time of Both SDA and SCL Signals (Note 12)	t _F	Fast mode	20 + 0.1C _B		300	ns
		Standard mode			300	
Setup Time for STOP Condition	t _{SU:STO}	Fast mode	0.6			μs
		Standard mode	4.7			
Capacitive Load for Each Bus Line (Note 12)	C _B				400	pF
Pulse Width of Spikes that Must be Suppressed by the Input Filter	t _{SP}	Fast mode		30		ns

Note 8: After this period, the first clock pulse is generated.

Note 9: A device must internally provide a hold time of at least 300ns for the SDA signal (see the V_{IHMIN} of the SCL signal) to bridge the undefined region of the falling edge of SCL.

Note 10: The maximum t_{HD:DAT} is only met if the device does not stretch the low period (t_{LOW}) of the SCL signal.

Note 11: A fast-mode device can be used in a standard-mode system, but the requirement t_{SU:DAT} ≥ 250ns must then be met. This is automatically the case if the device does not stretch the low period of the SCL signal. If such a device does stretch the LOW period of the SCL signal, it must output the next data bit to the SDA line t_R MAX + t_{SU:DAT} = 1000 + 250 = 1250ns before the SCL line is released.

Note 12: C_B—total capacitance of one bus line in pF.

I²C Digital Input RTC with Alarm

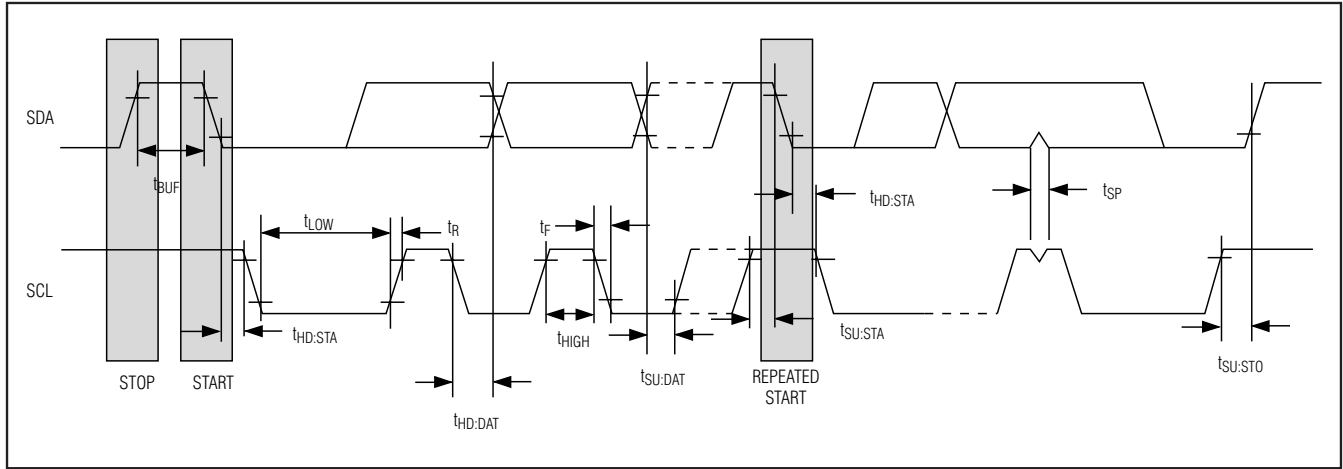

Figure 1. Data Transfer on I²C Serial Bus

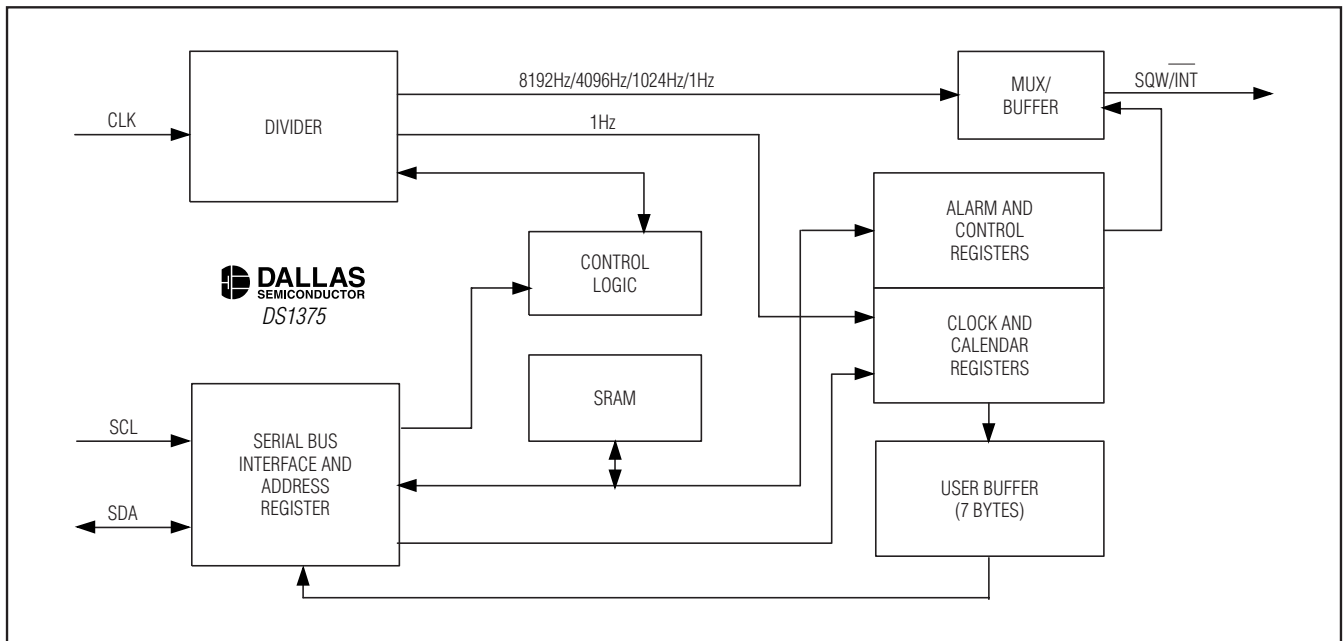

Figure 2. Functional Diagram

I²C Digital Input RTC with Alarm

Typical Operating Characteristics

(V_{CC} = +3.3V, T_A = +25°C, unless otherwise noted.)

DS1375

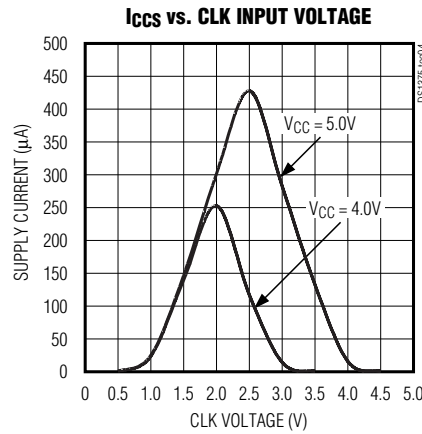
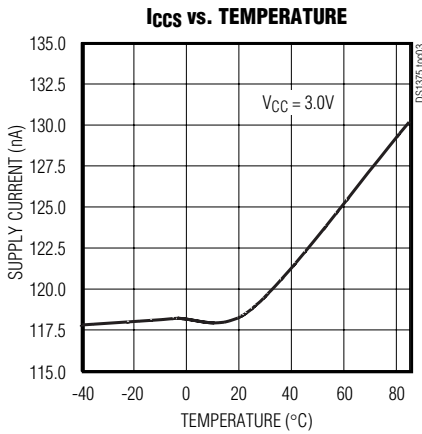
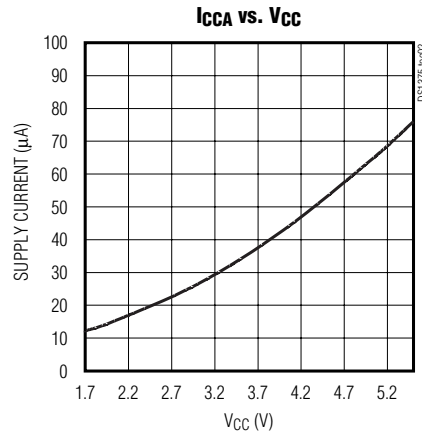
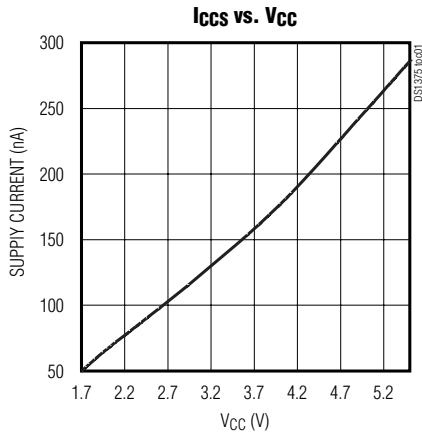

I²C Digital Input RTC with Alarm

Pin Description

PIN	NAME	FUNCTION
1	CLK	Digital Clock Input. This pin must be 32,768Hz, 8192Hz, 60Hz, or 50Hz square wave, 45% to 55% duty cycle.
2	SQW/INT	Square-Wave/Interrupt Output. This pin is open drain and requires an external pullup resistor. The pullup voltage can be up to 5.5V, regardless of the voltage on V _{CC} .
3	GND	Ground
4	SDA	Serial Data Input/Output. SDA is the data input/output for the I ² C serial interface. It is open drain and requires an external pullup resistor. The pullup voltage can be up to 5.5V, regardless of the voltage on V _{CC} .
5	SCL	Serial Clock Input. SCL is the clock input for the I ² C serial interface, and is used to synchronize data movement on the serial interface. Up to 5.5V can be used for this pin, regardless of the voltage on V _{CC} .
6	V _{CC}	DC Power for Primary Power Supply
—	EP	Exposed Pad. Can be connected to ground.

Detailed Description

The DS1375 digital input RTC with alarm is a low-power clock/calendar with two programmable time-of-day alarms and a programmable square-wave output. Address and data are transferred serially through the I²C serial interface bus. The clock/calendar provides seconds, minutes, hours, day, date, month, and year information. The date at the end of the month is automatically adjusted for months with fewer than 31 days, including corrections for leap year. The clock operates in either the 24-hour or 12-hour format with an AM/PM indicator. The DS1375 requires an external clock source selectable between 32,768Hz, 8192Hz, 60Hz, or 50Hz for the timekeeping function. Sixteen bytes of SRAM are provided for additional user storage.

When power is applied, the time and date registers are reset to 01/01/00 01 00:00:00 (MM/DD/YY DOW HH:MM:SS).

Operation

The DS1375 operates as a slave device on the serial bus. Access is obtained by implementing a START condition and providing a device identification code, followed by data. Subsequent registers can be accessed sequentially until a STOP condition is executed. The functional diagram in Figure 2 shows the main elements of the serial RTC.

Address Map

Table 1 shows the address map for the timekeeping registers and SRAM. The 16 bytes of SRAM occupy addresses 10h–1Fh. During a multibyte access, when the address pointer reaches the end of the register space (1Fh), it wraps around to location 00h. On a I²C START, STOP, or address pointer incrementing to location 00h, the current time is transferred to a second set of registers. The time information is read from these secondary registers, while the clock may continue to run. This eliminates the need to reread the registers in case the main registers update during a read.

Note: Unless otherwise specified, the state of the registers is not defined when power is first applied.

Clock and Calendar

The time and calendar information is obtained by reading the appropriate register bytes. Table 1 shows the RTC registers. The time and calendar data are set or initialized by writing the appropriate register bytes. The contents of the time and calendar registers are in the binary-coded decimal (BCD) format. The DS1375 can be run in either 12-hour or 24-hour mode. Bit 6 of the hours register is defined as the 12- or 24-hour mode select bit. When high, the 12-hour mode is selected. In the 12-hour mode, bit 5 is the AM/PM bit with logic high being PM. In the 24-hour mode, bit 5 is the second 10-hour bit (20–23 hours). The century bit (bit 7 of the

I²C Digital Input RTC with Alarm

Table 1. Timekeeping Registers and SRAM

ADDRESS	BIT 7	BIT 6	BIT 5	BIT 4	BIT 3	BIT 2	BIT 1	BIT 0	FUNCTION	RANGE
00h	0	10 Seconds			Seconds			Seconds	Seconds	00–59
01h	0	10 Minutes			Minutes			Minutes	Minutes	00–59
02h	0	12/24	AM/PM 10 Hours	10 Hours	Hours			Hours	Hours	1–12 + AM/PM 00–23
03h	0	0	0	0	0	Day		Day	Day	1–7
04h	0	0	10 Date		Date			Date	Date	00–31
05h	Century	0	0	10 Month	Months			Month/ Century	Month/ Century	01–12 + Century
06h	10 Year			Year			Year	Year	Year	00–99
07h	A1M1	10 Seconds			Seconds			Alarm 1 Seconds	Alarm 1 Seconds	00–59
08h	A1M2	10 Minutes			Minutes			Alarm 1 Minutes	Alarm 1 Minutes	00–59
09h	A1M3	12/24	AM/PM 10 Hours	10 Hours	Hours			Alarm 1 Hours	Alarm 1 Hours	1–12 + AM/PM 00–23
0Ah	A1M4	DY/DT	—		Day			Alarm 1 Day	Alarm 1 Day	1–7
			10 Date		Date			Alarm 1 Date	Alarm 1 Date	1–31
0Bh	A2M2	10 Minutes			Minutes			Alarm 2 Minutes	Alarm 2 Minutes	00–59
0Ch	A2M3	12/24	AM/PM 10 Hours	10 Hours	Hours			Alarm 2 Hours	Alarm 2 Hours	1–12 + AM/PM 00–23
0Dh	A2M4	DY/DT	—		Day			Alarm 2 Day	Alarm 2 Day	1–7
			10 Date		Date			Alarm 2 Date	Alarm 2 Date	1–31
0Eh	ECLK	CLKSEL1	CLKSEL0	RS2	RS1	INTCN	A2IE	A1IE	Control	—
0Fh	0	0	0	0	0	0	A2F	A1F	Control/ Status	—
10h–1Fh	B7	B6	B5	B4	B3	B2	B1	B0	SRAM	00–FFH

month register) is toggled when the years register overflows from 99 to 00.

The day-of-week register increments at midnight. Values that correspond to the day of week are user-defined but must be sequential (i.e., if 1 equals Sunday, then 2 equals Monday, and so on). Illogical time and date entries result in undefined operation.

When reading or writing the time and date registers, secondary (user) buffers are used to prevent errors when the internal registers update. When reading the time and date registers, the user buffers are synchronized to the internal registers on any START or STOP

and when the register pointer rolls over to zero. The time information is read from these secondary registers, while the clock continues to run. This eliminates the need to reread the registers in case the main registers update during a read.

The countdown chain is reset whenever the seconds register is written. Write transfers occur on the acknowledge from the DS1375. Once the countdown chain is reset, to avoid rollover issues the remaining time and date registers must be written within 1 second. The 1Hz square-wave output, if enabled, transitions high 500ms after the seconds data transfer, provided the clock input is already being driven.

I²C Digital Input RTC with Alarm

Alarms

The DS1375 contains two time-of-day/date alarms. Alarm 1 can be set by writing to registers 07h–0Ah. Alarm 2 can be set by writing to registers 0Bh–0Dh. The alarms can be programmed (by the alarm enable and INTCN bits of the control register) to activate the SQW/INT output on an alarm match condition. Bit 7 of the time-of-day/date alarm registers are mask bits (Table 2). When all the mask bits for each alarm are logic 0, an alarm only occurs when the values in the timekeeping registers match the corresponding values stored in the time-of-day/date alarm registers. The alarms can also be programmed to repeat every second, minute, hour, day, or date. Table 2 shows the possible settings. Configurations not listed in the table result in illogical operation.

The DY/DT bits (bit 6 of the alarm day/date registers) control whether the alarm value stored in bits 0–5 of

that register reflects the day of the week or the date of the month. If DY/DT is written to logic 0, the alarm is the result of a match with date of the month. If DY/DT is written to logic 1, the alarm is the result of a match with day of the week.

When the RTC register values match alarm register settings, the corresponding alarm flag A1F or A2F bit is set to logic 1. If the corresponding alarm interrupt enable A1IE or A2IE is also set to logic 1, and the INTCN bit is set to logic 1, the alarm condition activates the SQW/INT signal. The match is tested on the once-per-second update of the time and date registers.

Special Purpose Registers

The DS1375 has two additional registers (control and status) that control the RTC, alarms, and square-wave output.

Table 2. Alarm Mask Bits

DY/DT	ALARM 1 REGISTER MASK BITS (BIT 7)				ALARM RATE
	A1M	A1M	A1M	A1M	
X	1	1	1	1	Alarm once per second
X	1	1	1	0	Alarm when seconds match
X	1	1	0	0	Alarm when minutes and seconds match
X	1	0	0	0	Alarm when hours, minutes, and seconds match
0	0	0	0	0	Alarm when date, hours, minutes, and seconds match
1	0	0	0	0	Alarm when day, hours, minutes, and seconds match

DY/DT	ALARM 2 REGISTER MASK BITS (BIT 7)			ALARM RATE
	A2M	A2M	A2M	
X	1	1	1	Alarm once per minute (00 seconds of every min)
X	1	1	0	Alarm when minutes match
X	1	0	0	Alarm when hours and minutes match
0	0	0	0	Alarm when date, hours, and minutes match
1	0	0	0	Alarm when day, hours, and minutes match

I²C Digital Input RTC with Alarm

Control Register (0Eh)

Bit 7	Bit 6	Bit 5	Bit 4	Bit 3	Bit 2	Bit 1	Bit 0
ECLK	CLKSEL1	CLKSEL0	RS2	RS1	INTCN	A2IE	A1IE

Control Register (0Eh)

Bit 7/Enable Clock (ECLK). When ECLK is set to logic 1, the CLK input pin is enabled to clock the internal divider chain and advance the timekeeping registers. When ECLK is set to logic 0, the divider chain is held in reset, and the time is not allowed to advance. To synchronize the DS1375 time to a reference, write the ECLK bit to 0, write the time value, then write ECLK back to 1. Doing so synchronizes the time value to within one period of the CLK pin from the point in the interface protocol where the ECLK bit is written. ECLK is set to logic 1 when power is first applied.

Bits 6, 5/Clock Select Bits 1, 0 (CLKSEL1, CLKSEL0). These bits determine how the CLK input pin is divided down to get the 1Hz reference clock for the timekeeping registers (Table 3). The CLKSEL0–1 bits are cleared to logic 0 when power is first applied.

Bits 4, 3/Rate Select (RS2 and RS1). These bits control the frequency of the square-wave output when the square wave has been enabled and the CLKSEL0 and CLKSEL1 bits are set to 0. Table 3 shows the square-wave frequencies that can be selected with the RS bits. These bits are set to logic 1 (8.192kHz) when power is first applied. If either CLKSEL0 or CLKSEL1 are logic 1, the 1Hz signal is output.

Bit 2/Interrupt Control (INTCN). This bit controls the SQW/INT signal. When the INTCN bit is set to logic 0, a square wave is output on the SQW/INT pin. When the INTCN bit is set to logic 1, a match between the timekeeping registers and either of the alarm registers activates the SQW/INT (if the alarm is also enabled). The corresponding alarm flag is always set, regardless of the state of the INTCN bit. The INTCN bit is set to logic 0 when power is first applied.

Bit 1/Alarm 2 Interrupt Enable (A2IE). When set to logic 1, this bit permits the alarm 2 flag (A2F) bit in the status register to assert SQW/INT (when INTCN = 1). When the A2IE bit is set to logic 0 or INTCN is set to logic 0, the A2F bit does not initiate an interrupt signal. The A2IE bit is disabled (logic 0) when power is first applied.

Bit 0/Alarm 1 Interrupt Enable (A1IE). When set to logic 1, this bit permits the alarm 1 flag (A1F) bit in the status register to assert SQW/INT (when INTCN = 1). When the A1IE bit is set to logic 0 or INTCN is set to logic 0, the A1F bit does not initiate the SQW/INT signal. The A1IE bit is disabled (logic 0) when power is first applied.

Table 3. CLK Input Frequency, Square-Wave Output Frequency

INTCN	CLKSEL1	CLKSEL0	INPUT FREQUENCY	RS2	RS1	SQUARE-WAVE OUTPUT FREQUENCY
1	X	X	As selected	X	X	N/A (Interrupt)
0	0	0	32,768Hz	0	0	1Hz
0	0	0	32,768Hz	0	1	1.024kHz
0	0	0	32,768Hz	1	0	4.096kHz
0	0	0	32,768Hz	1	1	8.192kHz
0	0	1	8192Hz	X	X	1Hz
0	1	0	60Hz	X	X	1Hz
0	1	1	50Hz	X	X	1Hz

I²C Digital Input RTC with Alarm

Status Register (0Fh)

Bit 7	Bit 6	Bit 5	Bit 4	Bit 3	Bit 2	Bit 1	Bit 0
0	0	0	0	0	0	A2F	A1F

Status Register (0Fh)

Bit 1/Alarm 2 Flag (A2F). A logic 1 in the alarm 2 flag bit indicates that the time matched the alarm 2 registers. If the A2IE bit is logic 1 and the INTCN bit is set to logic 1, the SQW/INT pin is also asserted. A2F is cleared when written to logic 0. This bit can only be written to logic 0. Attempting to write to logic 1 leaves the value unchanged.

Bit 0/Alarm 1 Flag (A1F). A logic 1 in the alarm 1 flag bit indicates that the time matched the alarm 1 registers. If the A1IE bit is logic 1 and the INTCN bit is set to logic 1, the SQW/INT pin is also asserted. A1F is cleared when written to logic 0. This bit can only be written to logic 0. Attempting to write to logic 1 leaves the value unchanged.

I²C Serial Data Bus

The DS1375 supports a bidirectional I²C bus and data transmission protocol. A device that sends data onto the bus is defined as a transmitter and a device receiving data as a receiver. The device that controls the message is called a master. The devices that are controlled by the master are slaves. A master device that generates the serial clock (SCL), controls the bus access, and generates the START and STOP conditions must control the bus. The DS1375 operates as a slave on the I²C bus. Connections to the bus are made

through the open-drain I/O lines SDA and SCL. Within the bus specifications a standard mode (100kHz max clock rate) and a fast mode (400kHz max clock rate) are defined. The DS1375 works in both modes.

The following bus protocol has been defined (Figure 3):

- Data transfer can be initiated only when the bus is not busy.
- During data transfer, the data line must remain stable whenever the clock line is high. Changes in the data line while the clock line is high can be interpreted as control signals.

Accordingly, the following bus conditions have been defined:

Bus not busy: Both data and clock lines remain high.

Start data transfer: A change in the data line's state from high to low, while the clock line is high, defines a START condition.

Stop data transfer: A change in the data line's state from low to high, while the clock line is high, defines a STOP condition.

Data valid: The data line's state represents valid data when, after a START condition, the data line is stable for the duration of the high period of the clock signal. The data on the line must be changed

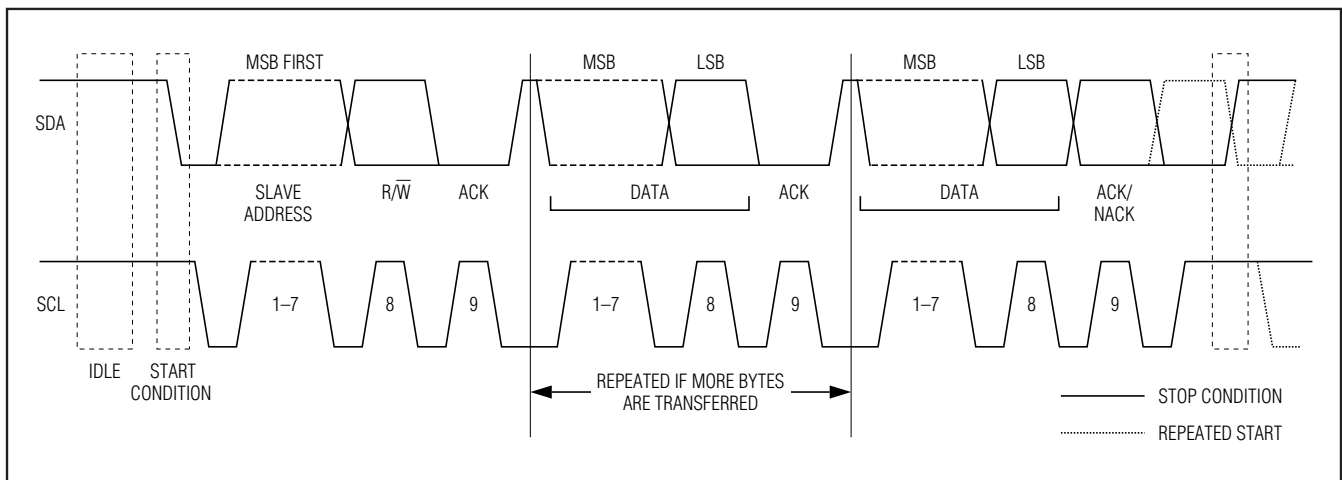

Figure 3. I²C Data Transfer Overview

I²C Digital Input RTC with Alarm

during the low period of the clock signal. There is one clock pulse per bit of data.

Each data transfer is initiated with a START condition and terminated with a STOP condition. The number of data bytes transferred between the START and the STOP conditions is not limited, and is determined by the master device. The information is transferred byte-wise and each receiver acknowledges with a ninth bit.

Acknowledge: Each receiving device, when addressed, is obliged to generate an acknowledge after the reception of each byte. The master device must generate an extra clock pulse that is associated with this acknowledge bit.

A device that acknowledges must pull down the SDA line during the acknowledge clock pulse in such a way that the SDA line is stable low during the high period of the acknowledge-related clock pulse. Setup and hold times must be taken into account. A master must signal an end of data to the slave by not generating an acknowledge bit on the last byte that has been clocked out of the slave. In this case, the slave must leave the data line high to enable the master to generate the STOP condition.

Figures 4 and 5 detail how data transfer is accomplished on the I²C bus. Depending upon the state of the R/W bit, two types of data transfer are possible:

Data transfer from a master transmitter to a slave receiver. The first byte transmitted by the master is the slave address. Next follows a number of data bytes. The slave returns an acknowledge bit after each received byte.

Data transfer from a slave transmitter to a master receiver. The master transmits the first byte (the slave address). The slave then returns an acknowledge bit. Next follows a number of data bytes transmitted by the slave to the master. The master returns an acknowledge bit after all received bytes, other than the last byte. At the end of the last received byte, a not acknowledge is returned.

The master device generates all the serial clock pulses and the START and STOP conditions. A transfer is ended with a STOP condition or with a repeated START condition. Since a repeated START condition is also the beginning of the next serial transfer, the bus is not released.

The DS1375 can operate in the following two modes:

Slave Receiver Mode (Write Mode): Serial data and clock are received through SDA and SCL. After each byte is received, an acknowledge bit is transmitted. START and STOP conditions are recognized as the beginning and end of a serial transfer. Address recognition is performed by hardware after reception of the slave address and direction bit. The slave address byte is the first byte received after the master generates the START condition. The slave address byte contains the 7-bit DS1375 address, which is 1101000, followed by the direction bit (R/W), which is 0 for a write. After receiving and decoding the slave address byte, the DS1375 outputs an acknowledge on SDA. After the DS1375 acknowledges the slave address + write bit, the master transmits a word address to the DS1375. This sets the register pointer on the DS1375, with the DS1375 acknowledging the transfer. The master can then transmit zero or more bytes of data, with the DS1375 acknowledging each byte received. The register pointer increments after each data byte is transferred. The master generates a STOP condition to terminate the data write.

Slave Transmitter Mode (Read Mode): The first byte is received and handled as in the slave receiver mode. However, in this mode, the direction bit indicates that the transfer direction is reversed. The DS1375 transmits serial data on SDA while the serial clock is input on SCL. START and STOP conditions are recognized as the beginning and end of a serial transfer. Address recognition is performed by hardware after reception of the slave address and direction bit. The slave address byte is the first byte received after the master generates the START condition. The slave address byte contains the 7-bit DS1375 address, which is 1101000, followed by the direction bit (R/W), which is 1 for a read. After receiving and decoding the slave address byte, the DS1375 outputs an acknowledge on SDA. The DS1375 then begins to transmit data starting with the register address pointed to by the register pointer. If the register pointer is not written to before the initiation of a read mode, the first address that is read is the last one stored in the register pointer. The DS1375 must receive a not acknowledge to end a read.

I2C Digital Input RTC with Alarm

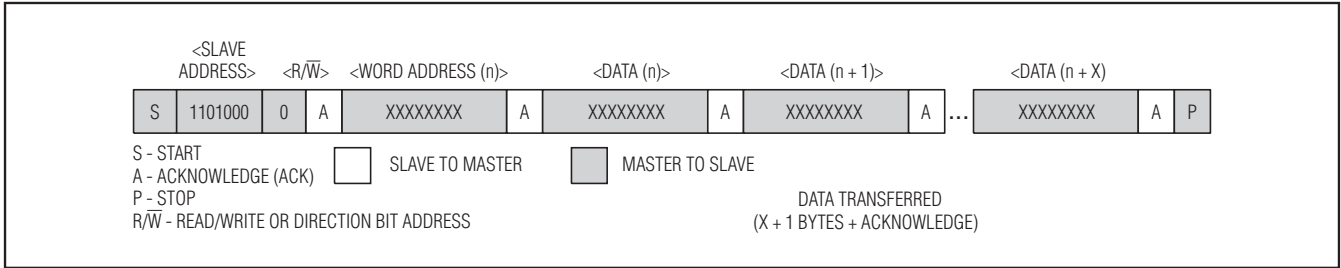

Figure 4. Data Write—Slave Receiver Mode

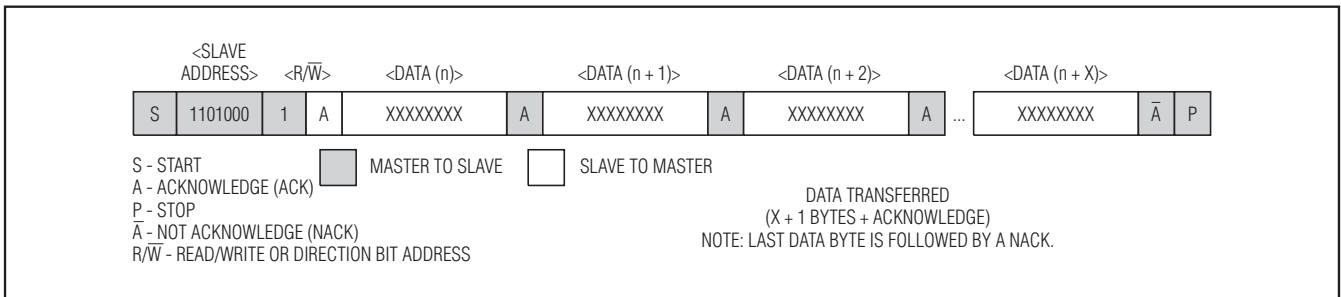

Figure 5. Data Read—Slave Transmitter Mode

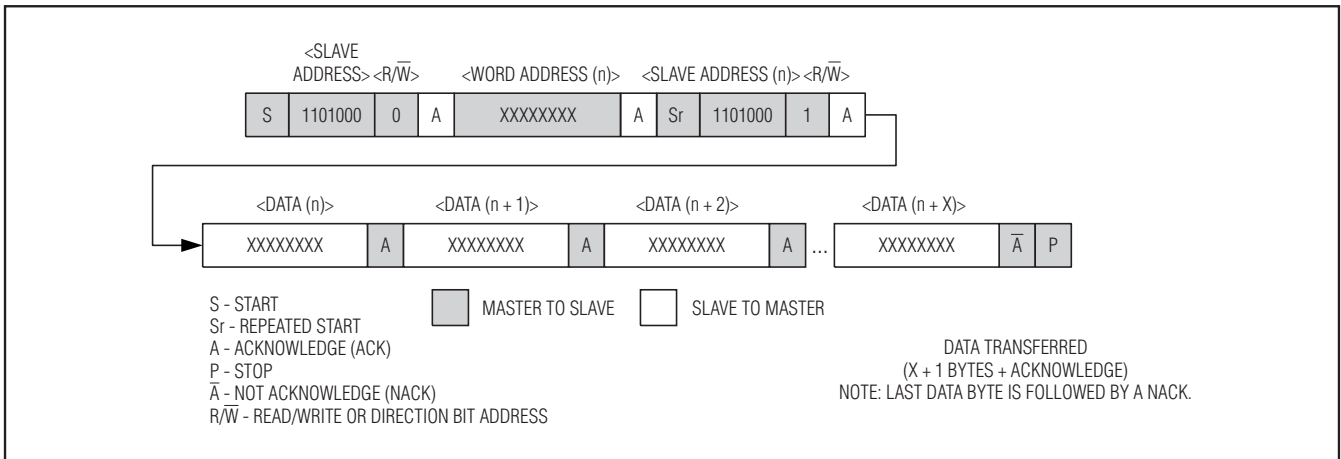

Figure 6. Data Write/Read (Write Pointer, Then Read)—Slave Receive and Transmit

Chip Information

TRANSISTOR COUNT: 11,797
 PROCESS: CMOS
 SUBSTRATE CONNECTED TO GROUND

Thermal Information

Theta-JA: 41°C/W
 Theta-JC: 2°C/W

Package Information

For the latest package outline information and land patterns, go to www.maxim-ic.com/packages.

PACKAGE TYPE	PACKAGE CODE	DOCUMENT NO.
6 TDFN-EP	T633+2	21-0137

I²C Digital Input RTC with Alarm

Revision History

DS1375

REVISION NUMBER	REVISION DATE	DESCRIPTION	PAGES CHANGED
0	4/03	Initial release.	—
1	1/04	Changed the package reference from TQFN to TDFN in the <i>Ordering Information</i> and <i>Pin Configuration</i> .	1
		Added link to the package drawing in the <i>Package Information</i> section.	11
2	9/08	Globally replaced “2-wire” with “I ² C”.	All
		Updated the <i>Ordering Information</i> to include the lead-free package; updated the <i>Pin Configuration</i> to show the lead-free exposed pad package.	1
		In the <i>Pin Description</i> , indicated that SCL, SDA, and SQW $\overline{\text{INT}}$ can be pulled up to 5.5V; also added the exposed pad information.	6
		Added time and date POR information to the <i>Detailed Description</i> .	6
		Replaced the I ² C write and read figures.	12
		Added the <i>Package Information</i> section table.	12

Maxim cannot assume responsibility for use of any circuitry other than circuitry entirely embodied in a Maxim product. No circuit patent licenses are implied. Maxim reserves the right to change the circuitry and specifications without notice at any time.

Maxim Integrated Products, 120 San Gabriel Drive, Sunnyvale, CA 94086 408-737-7600 _____ 13

© 2008 Maxim Integrated Products

MAXIM is a registered trademark of Maxim Integrated Products, Inc.

 **DALLAS SEMICONDUCTOR** is a registered trademark of Dallas Semiconductor Corporation.

Компания «Life Electronics» занимается поставками электронных компонентов импортного и отечественного производства от производителей и со складов крупных дистрибьюторов Европы, Америки и Азии.

С конца 2013 года компания активно расширяет линейку поставок компонентов по направлению коаксиальный кабель, кварцевые генераторы и конденсаторы (керамические, пленочные, электролитические), за счёт заключения дистрибьюторских договоров

Мы предлагаем:

- Конкурентоспособные цены и скидки постоянным клиентам.
- Специальные условия для постоянных клиентов.
- Подбор аналогов.
- Поставку компонентов в любых объемах, удовлетворяющих вашим потребностям.
- Приемлемые сроки поставки, возможна ускоренная поставка.
- Доставку товара в любую точку России и стран СНГ.
- Комплексную поставку.
- Работу по проектам и поставку образцов.
- Формирование склада под заказчика.
- Сертификаты соответствия на поставляемую продукцию (по желанию клиента).
- Тестирование поставляемой продукции.
- Поставку компонентов, требующих военную и космическую приемку.
- Входной контроль качества.
- Наличие сертификата ISO.

В составе нашей компании организован Конструкторский отдел, призванный помогать разработчикам, и инженерам.

Конструкторский отдел помогает осуществить:

- Регистрацию проекта у производителя компонентов.
- Техническую поддержку проекта.
- Защиту от снятия компонента с производства.
- Оценку стоимости проекта по компонентам.
- Изготовление тестовой платы монтаж и пусконаладочные работы.



Тел: +7 (812) 336 43 04 (многоканальный)

Email: org@lifeelectronics.ru