

ezPyro™ I²C Pyroelectric Infrared Sensor for Gas Sensing (SMD)

Introduction

The ezPyro range of thin film digital pyroelectric IR sensors for gas detection and concentration measurement combines high quality sensors with a high level of configurable electronic integration in a small SMD package. High sensitivity combined with fast response times ensure rapid and accurate detection of target gases. These sensors integrate a digital, current mode read-out that enables lower IR-emitter duty cycles, thereby saving significantly on system level power consumption, while maintaining high SNR. Programmable gain and filtering offer maximum flexibility in system design. Industry standard I²C communication enables plug-and-play connectivity to microcontrollers and allows easy tuning and calibration. ezPyro sensors are very stable over time ensuring a long and maintenance-free operational lifespan. Various optical filter options are available. These sensors can also be daisy-chained to allow synchronized sampling across devices.



Sensor Characteristics

Filter aperture	d = 1.65 mm
Element size	0.64 x 0.64 mm ²
SMD Package	5.65 x 3.7 x 1.55 mm
D* (typ.) ¹	2.5 x 10 ⁸ cm√Hz/ W
NEP (typ.) ¹	2.7 x 10 ⁻¹⁰ W/√Hz
Time Constant	~10ms (10-20 Hz peak)
Field of View	~90°

Electrical Characteristics

Supply voltage	1.75 to 3.6 V
Supply current (typ.)	1 to 23 μA
Digital I/O	I ² C (FM+ compatible)
ADC	15bit ΔΣ ADC @ 1ksp
Operating Temperature	-40 to +85 °C
Storage Temperature	-40 to +110 °C
Sensor read-out	Current mode Gain / digital filtering / sampling rate / power modes
Configurable	

1) Measured without filter @ 500K, 10 Hz, room temperature

Order Information

Part Number	Filter μm	Filter BW μm	Gas
ePY12211	3.91	90	Reference
ePY12221	3.30	160	CH ₄
ePY12231	4.26	180	CO ₂
ePY12241	4.64	180	CO
ePY12261	5.30	180	NO

Ordering Code	Description
ePYxxxxx-R7	800 pcs on 7" tape and reel
ePYxxxxx-R13	4000 pcs on 13" tape and reel
ePYxxxxx	bulk
ePYxxxxx-B1	Sensor on a breakout PCB

For more information contact: sales@pyreos.com

Please note: the information contained in this document is subject to change without further notification. Pyreos reserves the right to alter the performance and any resulting specification. Pyreos may choose not to supply any engineering sample devices as a commercial product. No responsibility is accepted for any consequential loss incurred. Pyreos Ltd, SMC, Alexander Crum Brown Road, Edinburgh EH9 3FF, UK. Tel: +441316507009, www.pyreos.com

Package Information



Signal Filtering & Power Modes

Power Mode (base sample rate)	High Pass Filter – Analog (Hz)					Fixed Analog Low Pass Filter (Hz)	Fixed Digital Low Pass Filter (Hz)	Digital Low Pass Filter (Hz)				Max ADC Sampling Rate (sps)
	Off	1	2	4	8			180	90	45	22.5	
Normal Power Mode	Off	1	2	4	8	600	250	180	90	45	22.5	1000
Low Power Mode	Off	0.17	0.33	0.66	1.3	100	42	30	15	7.5	3.75	166

	Mode	Description	Typical Current Consumption (1.8 V, room temperature)
Power consumption	Normal Power Mode	Normal power consumption, 1 kHz max. sample rate	22 μ A
	Low Power Mode	Low power consumption, 166 Hz max. sample rate	3.5 μ A
Operational state	Normal Operation Mode	Sensor signal readout over I ² C	22 μ A
	Sleep Mode	Hardware interrupt on infrared trigger	21 μ A (Normal), 3.5 μ A (Low)
	Power Down Mode	Sensor is disabled	1.1 μ A

Circuit Diagrams

Single Device Block Diagram

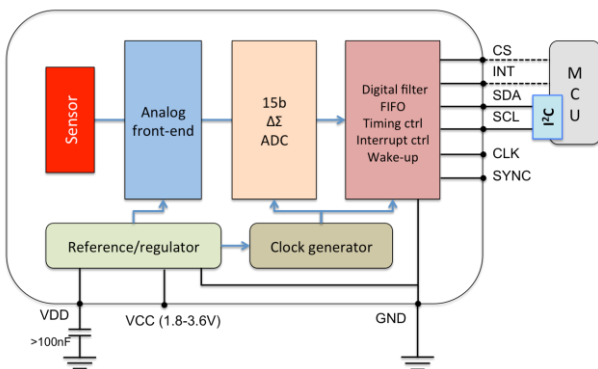

Three Devices with Synchronised Sampling

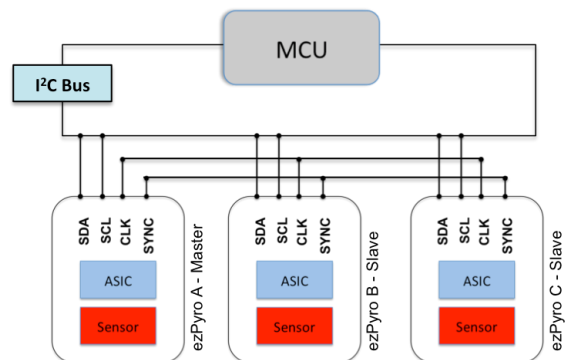

Please note: the information contained in this document is subject to change without further notification. Pyreos reserves the right to alter the performance and any resulting specification. Pyreos may choose not to supply any engineering sample devices as a commercial product. No responsibility is accepted for any consequential loss incurred. Pyreos Ltd, SMC, Alexander Crum Brown Road, Edinburgh EH9 3FF, UK. Tel: +441316507009, www.pyreos.com

Infrared Frequency Characteristics



Typical Frequency Response in Normal Power Mode



Typical Frequency Response in Low Power Mode



Typical Frequency Response at Different Gain Settings

Please note: the information contained in this document is subject to change without further notification. Pyreos reserves the right to alter the performance and any resulting specification. Pyreos may choose not to supply any engineering sample devices as a commercial product. No responsibility is accepted for any consequential loss incurred. Pyreos Ltd, SMC, Alexander Crum Brown Road, Edinburgh EH9 3FF, UK. Tel: +441316507009, www.pyreos.com

Компания «Life Electronics» занимается поставками электронных компонентов импортного и отечественного производства от производителей и со складов крупных дистрибьюторов Европы, Америки и Азии.

С конца 2013 года компания активно расширяет линейку поставок компонентов по направлению коаксиальный кабель, кварцевые генераторы и конденсаторы (керамические, пленочные, электролитические), за счёт заключения дистрибьюторских договоров

Мы предлагаем:

- Конкурентоспособные цены и скидки постоянным клиентам.
- Специальные условия для постоянных клиентов.
- Подбор аналогов.
- Поставку компонентов в любых объемах, удовлетворяющих вашим потребностям.
- Приемлемые сроки поставки, возможна ускоренная поставка.
- Доставку товара в любую точку России и стран СНГ.
- Комплексную поставку.
- Работу по проектам и поставку образцов.
- Формирование склада под заказчика.
- Сертификаты соответствия на поставляемую продукцию (по желанию клиента).
- Тестирование поставляемой продукции.
- Поставку компонентов, требующих военную и космическую приемку.
- Входной контроль качества.
- Наличие сертификата ISO.

В составе нашей компании организован Конструкторский отдел, призванный помогать разработчикам, и инженерам.

Конструкторский отдел помогает осуществить:

- Регистрацию проекта у производителя компонентов.
- Техническую поддержку проекта.
- Защиту от снятия компонента с производства.
- Оценку стоимости проекта по компонентам.
- Изготовление тестовой платы монтаж и пусконаладочные работы.



Тел: +7 (812) 336 43 04 (многоканальный)
Email: org@lifeelectronics.ru