

SCTA□D Series

Spring Contact Laser Welding Type

Improved reduction of Insertion loss by laser welding to double spiral spring



Features

- Space-saving compact size (1.4 × 1.4mm (1.45 × 1.45mm)) and low height
- Unique spring construction realizes high resilience to vibration and impacts, ensuring high contact reliability
- Square shape means orientation not a concern during mounting, allowing flexible arrangement (e.g. arrays)
- Supports 3A current despite compact dimensions
- Insulation coating prevents shorting paths (e.g. due to bending)

Applications

- Connection of devices requiring stable high frequency performance, and board-to-board or other connection inside electronic equipment

Typical Specifications

	SCTA1D	SCTA3D	SCTA4D	SCTA5D
Dimension (W x D)	1.4 × 1.4 mm	1.45 × 1.45 mm	1.45 × 1.45 mm	1.45 × 1.45 mm
Height in use	0.7 to 1.0 mm	1.05 to 1.35 mm	1.25 to 1.55 mm	1.45 to 1.75 mm
Travel	0.45 mm	0.5 mm	0.5 mm	0.5 mm
Rated current	3A			
Operating temperature range	-30 to +85°C			

Dimensions

Unit : mm

[SCTA1D]

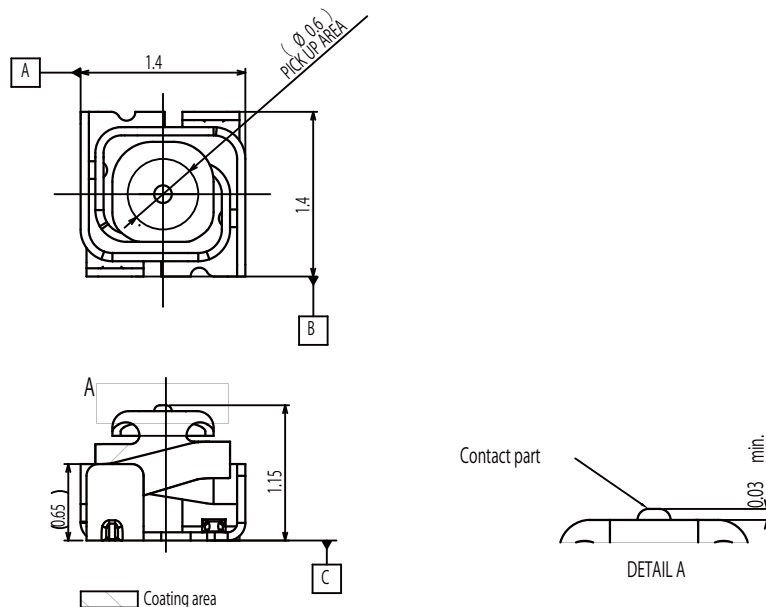

Precautions when handling our products

● For the export of products which are controlled items subject to foreign and domestic export laws and regulations, you must obtain approval and/or follow the formalities of such laws and regulations. ● Products must not be used for military and/or antisocial purposes such as terrorism, and shall not be supplied to any party intending to use the products for such purposes. ● Unless provided for otherwise, the products have been designed and manufactured for application in equipment and devices which are sold to end users in the market, including audio-visual (AV) equipment, electrical home appliances, office machines, information and communication equipment, and amusement equipment. The products are not intended for use in, and must not be used for, any application for nuclear equipment, driving equipment for aerospace or any other unauthorized use. With the exception of the abovementioned prohibited applications, please contact an Alps sales representative and/or evaluate the total system regarding applicability for applications involving high levels of safety and liability such as medical equipment, burglar alarm equipment, disaster prevention equipment and undersea equipment. Please also incorporate fail-safe design, protection and redundant circuitry, malfunction protection, and/or fire protection into the complete system to ensure safety and reliability of the total system. ● Before using products which were not specifically designed for use in automotive applications, please contact an Alps sales representative.

Cautions for using this catalog

● Specification indicated in this catalog is outline only. When employing the product, use of an officially authorized specification for supply contract is recommended. ● Please note that the colors of products shown in this catalog may be a little different from those of the actual products. ● Names for products and companies and titles of specifications indicated in this catalog are mostly trademarks or registered trademarks of their respective owners. ● Please contact us for any enquiries and queries on our products and their uses. ● This catalog is valid till the end of March 2018.

Компания «Life Electronics» занимается поставками электронных компонентов импортного и отечественного производства от производителей и со складов крупных дистрибьюторов Европы, Америки и Азии.

С конца 2013 года компания активно расширяет линейку поставок компонентов по направлению коаксиальный кабель, кварцевые генераторы и конденсаторы (керамические, пленочные, электролитические), за счёт заключения дистрибьюторских договоров

Мы предлагаем:

- Конкуренеспособные цены и скидки постоянным клиентам.
- Специальные условия для постоянных клиентов.
- Подбор аналогов.
- Поставку компонентов в любых объемах, удовлетворяющих вашим потребностям.
- Приемлемые сроки поставки, возможна ускоренная поставка.
- Доставку товара в любую точку России и стран СНГ.
- Комплексную поставку.
- Работу по проектам и поставку образцов.
- Формирование склада под заказчика.
- Сертификаты соответствия на поставляемую продукцию (по желанию клиента).
- Тестирование поставляемой продукции.
- Поставку компонентов, требующих военную и космическую приемку.
- Входной контроль качества.
- Наличие сертификата ISO.

В составе нашей компании организован Конструкторский отдел, призванный помогать разработчикам, и инженерам.

Конструкторский отдел помогает осуществить:

- Регистрацию проекта у производителя компонентов.
- Техническую поддержку проекта.
- Защиту от снятия компонента с производства.
- Оценку стоимости проекта по компонентам.
- Изготовление тестовой платы монтаж и пусконаладочные работы.



Тел: +7 (812) 336 43 04 (многоканальный)

Email: org@lifeelectronics.ru