

4-Mbit (512 K × 8/256 K × 16) nvSRAM with Real Time Clock

Features

- 25 ns and 45 ns access times
- Internally organized as 512 K × 8 (CY14B104K) or 256 K × 16 (CY14B104M)
- Hands off automatic STORE on power-down with only a small capacitor
- STORE to QuantumTrap nonvolatile elements is initiated by software, device pin, or AutoStore on power-down
- RECALL to SRAM is initiated by software or power-up
- High reliability
- Infinite read, write, and RECALL cycles
- 1 million STORE cycles to QuantumTrap
- 20 year data retention
- Single 3 V +20%, -10% operation
- Data integrity of Cypress nvSRAM combined with full-featured real time clock (RTC)

- Watchdog timer
- Clock alarm with programmable interrupts
- Capacitor or battery backup for RTC
- Industrial temperature
- 44-pin and 54-pin thin small outline package (TSOP) Type II
- Pb-free and restriction of hazardous substances (RoHS) compliant

Functional Description

The Cypress CY14B104K and CY14B104M combines a 4-Mbit nonvolatile static RAM (nvSRAM) with a full-featured RTC in a monolithic integrated circuit. The embedded nonvolatile elements incorporate QuantumTrap technology producing the world's most reliable nonvolatile memory. The SRAM is read and written infinite number of times, while independent nonvolatile data resides in the nonvolatile elements.

The RTC function provides an accurate clock with leap year tracking and a programmable, high accuracy oscillator. The alarm function is programmable for periodic minutes, hours, days, or months alarms. There is also a programmable watchdog timer for process control.

For a complete list of related documentation, click [here](#).

Logic Block

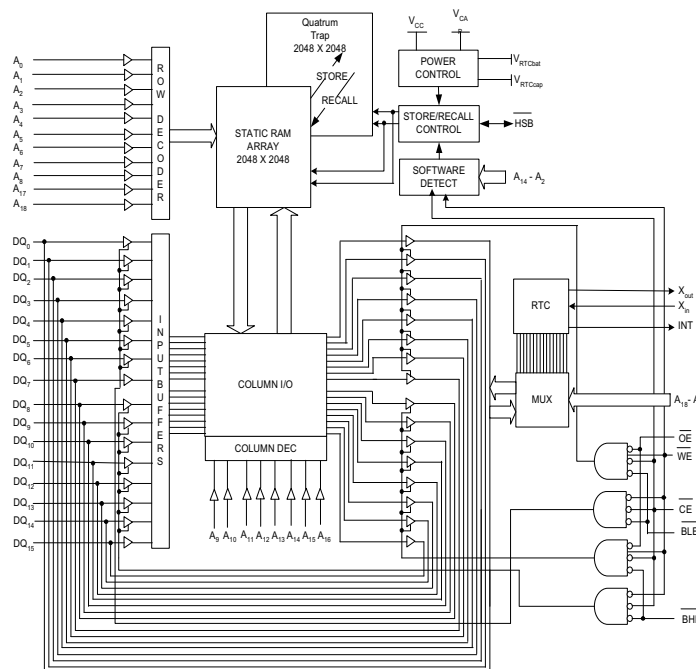

Notes

1. Address A₀-A₁₈ for × 8 configuration and Address A₀-A₁₇ for × 16 configuration.
2. Data DQ₀-DQ₇ for × 8 configuration and Data DQ₀-DQ₁₅ for × 16 configuration.
3. BHE and BLE are applicable for × 16 configuration only.

Contents

| | | | |
|--|-----------|--|-----------|
| Pin Definitions | 3 | DC Electrical Characteristics | 16 |
| Device Operation | 4 | Data Retention and Endurance | 17 |
| SRAM Read | 4 | Capacitance | 17 |
| SRAM Write | 4 | Thermal Resistance | 17 |
| AutoStore Operation | 4 | AC Test Loads | 18 |
| Hardware STORE (HSB) Operation | 5 | AC Test Conditions | 18 |
| Hardware RECALL (Power-Up) | 5 | RTC Characteristics | 18 |
| Software STORE | 5 | AC Switching Characteristics | 19 |
| Software RECALL | 5 | SRAM Read Cycle | 19 |
| Preventing AutoStore | 6 | SRAM Write Cycle | 19 |
| Data Protection | 7 | AutoStore/Power-Up RECALL | 22 |
| Real Time Clock Operation | 7 | Switching Waveforms – AutoStore/Power-up RECALL | 22 |
| nvTIME Operation | 7 | Software Controlled STORE and RECALL Cycle | 23 |
| Clock Operations | 7 | Hardware STORE Cycle | 24 |
| Reading the Clock | 7 | Truth Table For SRAM Operations | 25 |
| Setting the Clock | 7 | Ordering Information | 26 |
| Backup Power | 7 | Ordering Code Definitions | 26 |
| Stopping and Starting the Oscillator | 8 | Package Diagrams | 27 |
| Calibrating the Clock | 8 | Acronyms | 29 |
| Alarm | 8 | Document Conventions | 29 |
| Watchdog Timer | 8 | Units of Measure | 29 |
| Power Monitor | 9 | Document History Page | 30 |
| Interrupts | 9 | Sales, Solutions, and Legal Information | 35 |
| Flags Register | 10 | Worldwide Sales and Design Support | 35 |
| RTC External Components | 10 | Products | 35 |
| PCB Design Considerations for RTC | 11 | PSoC® Solutions | 35 |
| Layout requirements | 11 | Cypress Developer Community | 35 |
| Maximum Ratings | 16 | Technical Support | 35 |
| Operating Range | 16 | | |

Pinouts

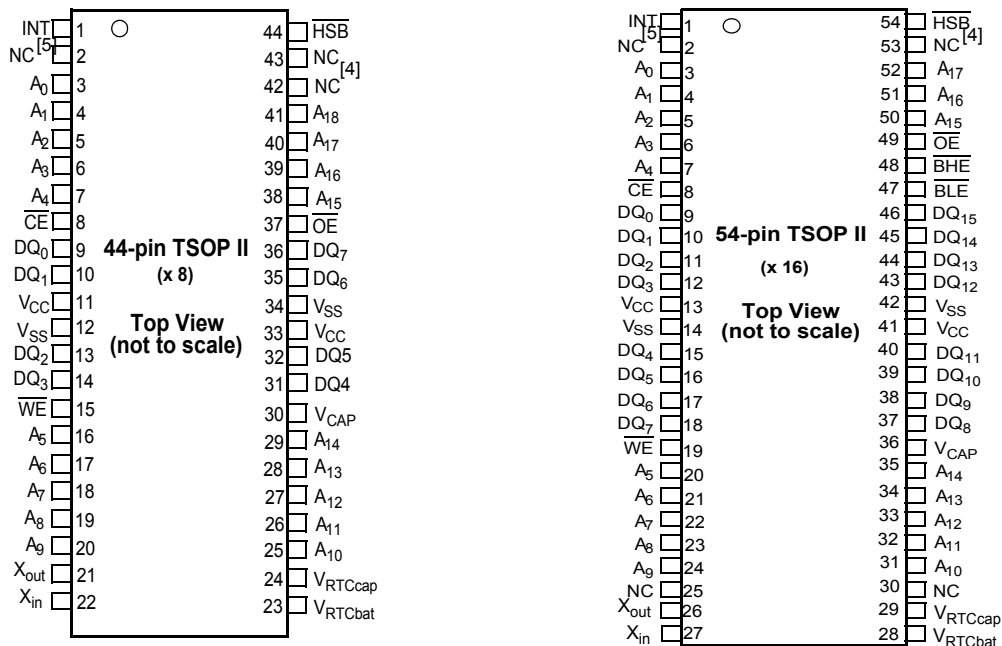
Figure 1. 44-pin TSOP II and 54-pin TSOP II pinouts

Pin Definitions

| Pin Name | I/O Type | Description |
|------------------------------------|--------------|--|
| A ₀ – A ₁₈ | Input | Address inputs. Used to select one of the 524,288 bytes of the nvSRAM for × 8 configuration. |
| A ₀ – A ₁₇ | Input | Address inputs. Used to select one of the 262,144 words of the nvSRAM for × 16 configuration. |
| DQ ₀ – DQ ₇ | Input/Output | Bidirectional data I/O lines for × 8 configuration. Used as input or output lines depending on operation. |
| DQ ₀ – DQ ₁₅ | Input/Output | Bidirectional data I/O lines for × 16 configuration. Used as input or output lines depending on operation. |
| NC | No connect | No connects. This pin is not connected to the die. |
| \overline{WE} | Input | Write Enable input, Active LOW. When selected LOW, data on the I/O pins is written to the specific address location. |
| \overline{CE} | Input | Chip Enable input, Active LOW. When LOW, selects the chip. When HIGH, deselects the chip. |
| \overline{OE} | Input | Output Enable, Active LOW. The active LOW \overline{OE} input enables the data output buffers during read cycles. Deasserting \overline{OE} HIGH causes the I/O pins to tristate. |
| \overline{BHE} | Input | Byte High Enable, Active LOW. Controls DQ ₁₅ –DQ ₈ . |
| \overline{BLE} | Input | Byte Low Enable, Active LOW. Controls DQ ₇ –DQ ₀ . |
| X _{out} ^[6] | Output | Crystal connection. Drives crystal on startup. |
| X _{in} ^[6] | Input | Crystal connection. For 32.768 kHz crystal. |
| V _{RTCcap} ^[6] | Power supply | Capacitor supplied backup RTC supply voltage. Left unconnected if V _{RTCbat} is used. |
| V _{RTCbat} ^[6] | Power supply | Battery supplied backup RTC supply voltage. Left unconnected if V _{RTCcap} is used. |
| INT ^[6] | Output | Interrupt output. Programmable to respond to the clock alarm, the watchdog timer, and the power monitor. Also programmable to either active HIGH (push or pull) or LOW (open drain). |

Notes

- Address expansion for 8-Mbit. NC pin not connected to die.
- Address expansion for 16-Mbit. NC pin not connected to die.
- Left unconnected if RTC feature is not used.

Pin Definitions (continued)

| Pin Name | I/O Type | Description |
|-------------------------|--------------|---|
| V _{SS} | Ground | Ground for the device. Must be connected to ground of the system. |
| V _{CC} | Power supply | Power supply inputs to the device. 3.0 V +20%, -10% |
| $\overline{\text{HSB}}$ | Input/Output | Hardware STORE Busy (HSB) Output: Indicates busy status of nvSRAM when LOW. After each Hardware and Software STORE operation, HSB is driven HIGH for a short time (t_{HHHD}) with standard output high current and then a weak internal pull-up resistor keeps this pin HIGH (external pull-up resistor connection optional). Input: Hardware STORE implemented by pulling this pin LOW externally. |
| V _{CAP} | Power supply | AutoStore capacitor. Supplies power to the nvSRAM during power loss to store data from SRAM to nonvolatile elements. |

Device Operation

The CY14B104K/CY14B104M nvSRAM is made up of two functional components paired in the same physical cell. These are a SRAM memory cell and a nonvolatile QuantumTrap cell. The SRAM memory cell operates as a standard fast static RAM. Data in the SRAM is transferred to the nonvolatile cell (the STORE operation), or from the nonvolatile cell to the SRAM (the RECALL operation). Using this unique architecture, all cells are stored and recalled in parallel. During the STORE and RECALL operations SRAM read and write operations are inhibited. The CY14B104K/CY14B104M supports infinite reads and writes similar to a typical SRAM. In addition, it provides infinite RECALL operations from the nonvolatile cells and up to 1 million STORE operations. See [Truth Table For SRAM Operations on page 25](#) for a complete description of read and write modes.

SRAM Read

The CY14B104K/CY14B104M performs a read cycle when $\overline{\text{CE}}$ and $\overline{\text{OE}}$ are LOW, and $\overline{\text{WE}}$ and $\overline{\text{HSB}}$ are HIGH. The address specified on pins A₀₋₁₈ or A₀₋₁₇ determines which of the 524,288 data bytes or 262,144 words of 16 bits each are accessed. Byte enables (BHE, BLE) determine which bytes are enabled to the output, in the case of 16-bit words. When the read is initiated by an address transition, the outputs are valid after a delay of t_{AA} (read cycle 1). If the read is initiated by $\overline{\text{CE}}$ or $\overline{\text{OE}}$, the outputs are valid at t_{ACE} or t_{DOE} , whichever is later (read cycle 2). The data output repeatedly responds to address changes within the t_{AA} access time without the need for transitions on any control input pins. This remains valid until another address change or until $\overline{\text{CE}}$ or $\overline{\text{OE}}$ is brought HIGH, or $\overline{\text{WE}}$ or $\overline{\text{HSB}}$ is brought LOW.

SRAM Write

A write cycle is performed when $\overline{\text{CE}}$ and $\overline{\text{WE}}$ are LOW and $\overline{\text{HSB}}$ is HIGH. The address inputs must be stable before entering the write cycle and must remain stable until $\overline{\text{CE}}$ or $\overline{\text{WE}}$ goes HIGH at the end of the cycle. The data on the common I/O pins DO₀₋₁₅ are written into the memory if it is valid t_{SD} before the end of a $\overline{\text{WE}}$ controlled write or before the end of an $\overline{\text{CE}}$ controlled write. The Byte Enable inputs (BHE, BLE) determine which bytes are written, in the case of 16-bit words. It is recommended that $\overline{\text{OE}}$ be kept HIGH during the entire write cycle to avoid data bus contention on common I/O lines. If $\overline{\text{OE}}$ is left LOW, internal circuitry turns off the output buffers t_{HZWE} after $\overline{\text{WE}}$ goes LOW.

AutoStore Operation

The CY14B104K/CY14B104M stores data to the nvSRAM using one of three storage operations. These three operations are: Hardware STORE, activated by the HSB; Software STORE, activated by an address sequence; AutoStore, on device power-down. The AutoStore operation is a unique feature of QuantumTrap technology and is enabled by default on the CY14B104K/CY14B104M.

During a normal operation, the device draws current from V_{CC} to charge a capacitor connected to the V_{CAP} pin. This stored charge is used by the chip to perform a single STORE operation. If the voltage on the V_{CC} pin drops below V_{SWITCH}, the part automatically disconnects the V_{CAP} pin from V_{CC}. A STORE operation is initiated with power provided by the V_{CAP} capacitor.

Note If the capacitor is not connected to V_{CAP} pin, AutoStore must be disabled using the soft sequence specified in [Preventing AutoStore on page 6](#). In case AutoStore is enabled without a capacitor on V_{CAP} pin, the device attempts an AutoStore operation without sufficient charge to complete the Store. This corrupts the data stored in nvSRAM.

Figure 2. AutoStore Mode

Figure 2 on page 4 shows the proper connection of the storage capacitor (V_{CAP}) for automatic STORE operation. Refer to [DC Electrical Characteristics on page 16](#) for the size of the V_{CAP}. The voltage on the V_{CAP} pin is driven to V_{CC} by a regulator on the

chip. A pull-up should be placed on \overline{WE} to hold it inactive during power-up. This pull-up is effective only if the \overline{WE} signal is tristate during power-up. Many MPUs tristate their controls on power-up. This should be verified when using the pull-up. When the nvSRAM comes out of power-on-RECALL, the MPU must be active or the \overline{WE} held inactive until the MPU comes out of reset.

To reduce unnecessary nonvolatile STOREs, AutoStore, and Hardware STORE operations are ignored unless at least one write operation has taken place since the most recent STORE or RECALL cycle. Software initiated STORE cycles are performed regardless of whether a write operation has taken place.

Hardware STORE (\overline{HSB}) Operation

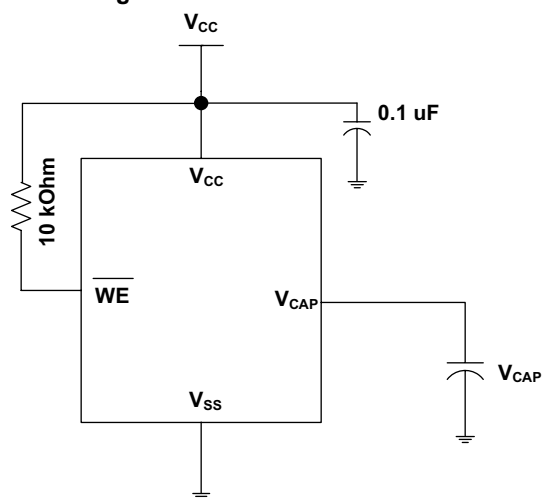
The CY14B104K/CY14B104M provides the \overline{HSB} pin to control and acknowledge the STORE operations. The \overline{HSB} pin is used to request a Hardware STORE cycle. When the \overline{HSB} pin is driven LOW, the CY14B104K/CY14B104M conditionally initiates a STORE operation after t_{DELAY} . An actual STORE cycle begins only if a write to the SRAM has taken place since the last STORE or RECALL cycle. The \overline{HSB} pin also acts as an open drain driver (internal 100 k Ω weak pull-up resistor) that is internally driven LOW to indicate a busy condition when the STORE (initiated by any means) is in progress.

Note After each Hardware and Software STORE operation \overline{HSB} is driven HIGH for a short time (t_{HHHD}) with standard output high current and then remains HIGH by internal 100 k Ω pull-up resistor.

SRAM write operations that are in progress when \overline{HSB} is driven LOW by any means are given time (t_{DELAY}) to complete before the STORE operation is initiated. However, any SRAM write cycles requested after \overline{HSB} goes LOW are inhibited until \overline{HSB} returns HIGH. In case the write latch is not set, \overline{HSB} is not driven LOW by the CY14B104K/CY14B104M. But any SRAM read and write cycles are inhibited until \overline{HSB} is returned HIGH by MPU or other external source.

During any STORE operation, regardless of how it is initiated, the CY14B104K/CY14B104M continues to drive the \overline{HSB} pin LOW, releasing it only when the STORE is complete. Upon completion of the STORE operation, the nvSRAM memory access is inhibited for t_{LZHSB} time after \overline{HSB} pin returns HIGH. Leave the \overline{HSB} unconnected if it is not used.

Hardware RECALL (Power-Up)

During power-up or after any low power condition ($V_{CC} < V_{SWITCH}$), an internal RECALL request is latched. When V_{CC} again exceeds the V_{SWITCH} on powerup, a RECALL cycle is automatically initiated and takes $t_{HRECALL}$ to complete. During this time, the \overline{HSB} pin is driven LOW by the \overline{HSB} driver and all reads and writes to nvSRAM are inhibited.

Software STORE

Data is transferred from the SRAM to the nonvolatile memory by a software address sequence. The CY14B104K/CY14B104M Software STORE cycle is initiated by executing sequential \overline{CE} or \overline{OE} controlled read cycles from six specific address locations in exact order. During the STORE cycle, an erase of the previous nonvolatile data is first performed, followed by a program of the nonvolatile elements. After a STORE cycle is initiated, further input and output are disabled until the cycle is completed.

Because a sequence of reads from specific addresses is used for STORE initiation, it is important that no other read or write accesses intervene in the sequence, or the sequence is aborted and no STORE or RECALL takes place. To initiate the Software STORE cycle, the following read sequence must be performed:

1. Read address 0x4E38 Valid READ
2. Read address 0xB1C7 Valid READ
3. Read address 0x83E0 Valid READ
4. Read address 0x7C1F Valid READ
5. Read address 0x703F Valid READ
6. Read address 0x8FC0 Initiate STORE cycle

The software sequence may be clocked with \overline{CE} controlled reads or \overline{OE} controlled reads, with \overline{WE} kept HIGH for all the six READ sequences. After the sixth address in the sequence is entered, the STORE cycle commences and the chip is disabled. \overline{HSB} is driven LOW. After the t_{STORE} cycle time is fulfilled, the SRAM is activated again for the read and write operation.

Software RECALL

Data is transferred from the nonvolatile memory to the SRAM by a software address sequence. A software RECALL cycle is initiated with a sequence of read operations in a manner similar to the Software STORE initiation. To initiate the RECALL cycle, perform the following sequence of \overline{CE} or \overline{OE} controlled read operations:

1. Read address 0x4E38 Valid READ
2. Read address 0xB1C7 Valid READ
3. Read address 0x83E0 Valid READ
4. Read address 0x7C1F Valid READ
5. Read address 0x703F Valid READ
6. Read address 0x4C63 Initiate RECALL cycle

Internally, RECALL is a two step procedure. First, the SRAM data is cleared; then, the nonvolatile information is transferred into the SRAM cells. After the t_{RECALL} cycle time, the SRAM is again ready for read and write operations. The RECALL operation does not alter the data in the nonvolatile elements.

Table 1. Mode Selection

| \overline{CE} | \overline{WE} | \overline{OE} | $\overline{BHE}, \overline{BLE}^{[7]}$ | $A_{15}-A_0^{[8]}$ | Mode | I/O | Power |
|-----------------|-----------------|-----------------|--|--|--|--|--|
| H | X | X | X | X | Not selected | Output High Z | Standby |
| L | H | L | L | X | Read SRAM | Output data | Active |
| L | L | X | L | X | Write SRAM | Input data | Active |
| L | H | L | X | 0x4E38 0xB1C7 0x83E0 0x7C1F 0x703F 0x8B45 | Read SRAM Read SRAM Read SRAM Read SRAM Read SRAM AutoStore Disable | Output data Output data Output data Output data Output data Output data | Active ^[9] |
| L | H | L | X | 0x4E38 0xB1C7 0x83E0 0x7C1F 0x703F 0x4B46 | Read SRAM Read SRAM Read SRAM Read SRAM Read SRAM AutoStore Enable | Output data Output data Output data Output data Output data Output data | Active ^[9] |
| L | H | L | X | 0x4E38 0xB1C7 0x83E0 0x7C1F 0x703F 0x8FC0 | Read SRAM Read SRAM Read SRAM Read SRAM Read SRAM Nonvolatile STORE | Output data Output data Output data Output data Output data Output High Z | Active I _{CC2} ^[9] |
| L | H | L | X | 0x4E38 0xB1C7 0x83E0 0x7C1F 0x703F 0x4C63 | Read SRAM Read SRAM Read SRAM Read SRAM Read SRAM Nonvolatile RECALL | Output data Output data Output data Output data Output data Output High Z | Active ^[9] |

Preventing AutoStore

The AutoStore function is disabled by initiating an AutoStore disable sequence. A sequence of read operations is performed in a manner similar to the Software STORE initiation. To initiate the AutoStore disable sequence, the following sequence of \overline{CE} or \overline{OE} controlled read operations must be performed:

1. Read address 0x4E38 Valid READ
2. Read address 0xB1C7 Valid READ
3. Read address 0x83E0 Valid READ
4. Read address 0x7C1F Valid READ
5. Read address 0x703F Valid READ
6. Read address 0x8B45 AutoStore Disable

The AutoStore is re-enabled by initiating an AutoStore enable sequence. A sequence of read operations is performed in a manner similar to the software RECALL initiation. To initiate the

AutoStore enable sequence, the following sequence of \overline{CE} or \overline{OE} controlled read operations must be performed:

1. Read address 0x4E38 Valid READ
2. Read address 0xB1C7 Valid READ
3. Read address 0x83E0 Valid READ
4. Read address 0x7C1F Valid READ
5. Read address 0x703F Valid READ
6. Read address 0x4B46 AutoStore Enable

If the AutoStore function is disabled or re-enabled, a manual STORE operation (hardware or software) must be issued to save the AutoStore state through subsequent power-down cycles. The part comes from the factory with AutoStore enabled and 0x00 written in all cells.

Notes

7. BHE and BLE are applicable for × 16 configuration only.
8. While there are 19 address lines on the CY14B104K (18 address lines on the CY14B104M), only 13 address lines ($A_{14}-A_2$) are used to control software modes. The remaining address lines are don't care.
9. The six consecutive address locations must be in the order listed. \overline{WE} must be HIGH during all six cycles to enable a nonvolatile cycle.

Data Protection

The CY14B104K/CY14B104M protects data from corruption during low-voltage conditions by inhibiting all externally initiated STORE and write operations. The low-voltage condition is detected when V_{CC} is less than V_{SWITCH} . If the CY14B104K/CY14B104M is in a write mode (both CE and WE are LOW) at power-up, after a RECALL or STORE, the write is inhibited until the SRAM is enabled after t_{LZHSB} (HSB to output active). This protects against inadvertent writes during power-up or brown out conditions.

Real Time Clock Operation

nvTIME Operation

The CY14B104K/CY14B104M offers internal registers that contain clock, alarm, watchdog, interrupt, and control functions. RTC registers use the last 16 address locations of the SRAM. Internal double buffering of the clock and timer information registers prevents accessing transitional internal clock data during a read or write operation. Double buffering also circumvents disrupting normal timing counts or the clock accuracy of the internal clock when accessing clock data. Clock and alarm registers store data in BCD format.

RTC functionality is described with respect to CY14B104K in the following sections. The same description applies to CY14B104M, except for the RTC register addresses. The RTC register addresses for CY14B104K range from 0x7FFF0 to 0x7FFFF, while those for CY14B104M range from 0x3FFF0 to 0x3FFFF. Refer to [Table 3 on page 12](#) and [Table 4 on page 13](#) for a detailed Register Map description.

Clock Operations

The clock registers maintain time up to 9,999 years in one-second increments. The time can be set to any calendar time and the clock automatically keeps track of days of the week and month, leap years, and century transitions. There are eight registers dedicated to the clock functions, which are used to set time with a write cycle and to read time with a read cycle. These registers contain the time of day in BCD format. Bits defined as '0' are currently not used and are reserved for future use by Cypress.

Reading the Clock

The double buffered RTC register structure reduces the chance of reading incorrect data from the clock. Internal updates to the CY14B104K time keeping registers are stopped when the read bit 'R' (in the Flags register at 0x7FFF0) is set to '1' before reading clock data to prevent reading of data in transition. Stopping the register updates does not affect clock accuracy.

When a read sequence of RTC device is initiated, the update of the user timekeeping registers stops and does not restart until a '0' is written to the read bit 'R' (in the Flags register at 0x7FFF0). After the end of read sequence, all the RTC registers are simultaneously updated within 20 ms.

Setting the Clock

A write access to the RTC device stops updates to the time keeping registers and enables the time to be set when the write bit 'W' (in the Flags register at 0x7FFF0) is set to '1'. The correct day, date, and time is then written into the registers and must be

in 24 hour BCD format. The time written is referred to as the "Base Time". This value is stored in nonvolatile registers and used in the calculation of the current time. When the write bit 'W' is cleared by writing '0' to it, the values of timekeeping registers are transferred to the actual clock counters after which the clock resumes normal operation.

If the time written to the timekeeping registers is not in the correct BCD format, each invalid nibble of the RTC registers continue counting to 0xF before rolling over to 0x0 after which RTC resumes normal operation.

Note After 'W' bit is set to '0', values written into the timekeeping, alarm, calibration, and interrupt registers are transferred to the RTC time keeping counters in t_{RTCP} time. These counter values must be saved to nonvolatile memory either by initiating a Software/Hardware STORE or AutoStore operation. While working in AutoStore disabled mode, perform a STORE operation after t_{RTCP} time while writing into the RTC registers for the modifications to be correctly recorded.

Backup Power

The RTC in the CY14B104K is intended for permanently powered operation. The V_{RTCCap} or V_{RTCbat} pin is connected depending on whether a capacitor or battery is chosen for the application. When the primary power, V_{CC} , fails and drops below V_{SWITCH} the device switches to the backup power supply.

The clock oscillator uses very little current, which maximizes the backup time available from the backup source. Regardless of the clock operation with the primary source removed, the data stored in the nvSRAM is secure, having been stored in the nonvolatile elements when power was lost.

During backup operation, the CY14B104K consumes a 0.35 μA (Typ) at room temperature. The user must choose capacitor or battery values according to the application.

Note: If a battery is applied to V_{RTCbat} pin prior to V_{CC} , the chip will draw high I_{BAK} current. This occurs even if the oscillator is disabled. In order to maximize battery life, V_{CC} must be applied before a battery is applied to V_{RTCbat} pin.

Backup time values based on maximum current specifications are shown in the following [Table 2](#). Nominal backup times are approximately two times longer.

Table 2. RTC Backup Time

| Capacitor Value | Backup Time |
|-----------------|-------------|
| 0.1 F | 72 hours |
| 0.47 F | 14 days |
| 1.0 F | 30 days |

Using a capacitor has the obvious advantage of recharging the backup source each time the system is powered up. If a battery is used, a 3 V lithium is recommended and the CY14B104K sources current only from the battery when the primary power is removed. However the battery is not recharged at any time by the CY14B104K. The battery capacity must be chosen for total anticipated cumulative down time required over the life of the system.

Stopping and Starting the Oscillator

The OSCEN bit in the calibration register at 0x7FFF8 controls the enable and disable of the oscillator. This bit is nonvolatile and is shipped to customers in the “enabled” (set to ‘0’) state. To preserve the battery life when the system is in storage, OSCEN must be set to ‘1’. This turns off the oscillator circuit, extending the battery life. If the OSCEN bit goes from disabled to enabled, it takes approximately one second (two seconds maximum) for the oscillator to start.

While system power is off, if the voltage on the backup supply (V_{RTCcap} or V_{RTCbat}) falls below their respective minimum level, the oscillator may fail. The CY14B104K has the ability to detect oscillator failure when system power is restored. This is recorded in the Oscillator Fail Flag (OSCF) of the Flags register at the address 0x7FFF0. When the device is powered on (V_{CC} goes above V_{SWITCH}) the OSCEN bit is checked for the ‘enabled’ status. If the OSCEN bit is enabled and the oscillator is not active within the first 5 ms, the OSCF bit is set to ‘1’. The system must check for this condition and then write ‘0’ to clear the flag.

Note that in addition to setting the OSCF flag bit, the time registers are reset to the ‘Base Time’, which is the value last written to the timekeeping registers. The control or calibration registers and the OSCEN bit are not affected by the ‘oscillator failed’ condition.

The value of OSCF must be reset to ‘0’ when the time registers are written for the first time. This initializes the state of this bit which may have become set when the system was first powered on.

To reset OSCF, set the write bit ‘W’ (in the Flags register at 0x7FFF0) to a ‘1’ to enable writes to the Flags register. Write a ‘0’ to the OSCF bit and then reset the write bit to ‘0’ to disable writes.

Calibrating the Clock

The RTC is driven by a quartz controlled crystal with a nominal frequency of 32.768 kHz. Clock accuracy depends on the quality of the crystal and calibration. The crystals available in market typically have an error of ± 20 ppm to ± 35 ppm. However, CY14B104K employs a calibration circuit that improves the accuracy to $+1/-2$ ppm at 25 °C. This implies an error of $+2.5$ seconds to -5 seconds per month.

The calibration circuit adds or subtracts counts from the oscillator divider circuit to achieve this accuracy. The number of pulses that are suppressed (subtracted, negative calibration) or split (added, positive calibration) depends upon the value loaded into the five calibration bits found in Calibration register at 0x7FFF8. The calibration bits occupy the five lower order bits in the Calibration register. These bits are set to represent any value between ‘0’ and 31 in binary form. Bit D5 is a sign bit, where a ‘1’ indicates positive calibration and a ‘0’ indicates negative calibration. Adding counts speeds the clock up and subtracting counts slows the clock down. If a binary ‘1’ is loaded into the register, it corresponds to an adjustment of 4.068 or -2.034 ppm offset in oscillator error, depending on the sign.

Calibration occurs within a 64-minute cycle. The first 62 minutes in the cycle may, once every minute, have one second shortened by 128 or lengthened by 256 oscillator cycles. If a binary ‘1’ is loaded into the register, only the first two minutes of the 64-minute cycle are modified. If a binary 6 is loaded, the first 12 are affected, and so on. Therefore, each calibration step has the

effect of adding 512 or subtracting 256 oscillator cycles for every 125,829,120 actual oscillator cycles, that is, 4.068 or -2.034 ppm of adjustment per calibration step in the Calibration register.

To determine the required calibration, the CAL bit in the Flags register (0x7FFF0) must be set to ‘1’. This causes the INT pin to toggle at a nominal frequency of 512 Hz. Any deviation measured from the 512 Hz indicates the degree and direction of the required correction. For example, a reading of 512.01024 Hz indicates a $+20$ ppm error. Hence, a decimal value of -10 (001010b) must be loaded into the Calibration register to offset this error.

Note Setting or changing the Calibration register does not affect the test output frequency.

To set or clear CAL, set the write bit ‘W’ (in the Flags register at 0x7FFF0) to ‘1’ to enable writes to the Flags register. Write a value to CAL, and then reset the write bit to ‘0’ to disable writes.

Alarm

The alarm function compares user programmed values of alarm time and date (stored in the registers 0x7FFF1-5) with the corresponding time of day and date values. When a match occurs, the alarm internal flag (AF) is set and an interrupt is generated on INT pin if Alarm Interrupt Enable (AIE) bit is set.

There are four alarm match fields – date, hours, minutes, and seconds. Each of these fields has a match bit that is used to determine if the field is used in the alarm match logic. Setting the match bit to ‘0’ indicates that the corresponding field is used in the match process. Depending on the match bits, the alarm occurs as specifically as once a month or as frequently as once every minute. Selecting none of the match bits (all 1s) indicates that no match is required and therefore, alarm is disabled. Selecting all match bits (all 0s) causes an exact time and date match.

There are two ways to detect an alarm event: by reading the AF flag or monitoring the INT pin. The AF flag in the Flags register at 0x7FFF0 indicates that a date or time match has occurred. The AF bit is set to ‘1’ when a match occurs. Reading the Flags register clears the alarm flag bit (and all others). A hardware interrupt pin may also be used to detect an alarm event.

To set, clear or enable an alarm, set the ‘W’ bit (in Flags Register – 0x7FFF0) to ‘1’ to enable writes to Alarm Registers. After writing the alarm value, clear the ‘W’ bit back to ‘0’ for the changes to take effect.

Note CY14B104K requires the alarm match bit for seconds (bit ‘D7’ in Alarm-Seconds register 0x7FFF2) to be set to ‘0’ for proper operation of Alarm Flag and Interrupt.

Watchdog Timer

The watchdog timer is a free running down counter that uses the 32-Hz clock (31.25 ms) derived from the crystal oscillator. The oscillator must be running for the watchdog to function. It begins counting down from the value loaded in the watchdog timer register.

The timer consists of a loadable register and a free running counter. On power-up, the watchdog time out value in register 0x7FFF7 is loaded into the counter load register. Counting begins on power-up and restarts from the loadable value any time the watchdog strobe (WDS) bit is set to ‘1’. The counter is compared to the terminal value of ‘0’. If the counter reaches this value, it causes an internal flag and an optional interrupt output.

You can prevent the time out interrupt by setting WDS bit to '1' prior to the counter reaching '0'. This causes the counter to reload with the watchdog time out value and to be restarted. As long as the user sets the WDS bit prior to the counter reaching the terminal value, the interrupt and WDT flag never occur.

New time out values are written by setting the watchdog write bit to '0'. When the WDW is '0', new writes to the watchdog time out value bits D5–D0 are enabled to modify the time out value. When WDW is '1', writes to bits D5–D0 are ignored. The WDW function enables a user to set the WDS bit without concern that the watchdog timer value is modified. A logical diagram of the watchdog timer is shown in [Figure 3](#). Note that setting the watchdog time out value to '0' disables the watchdog function.

The output of the watchdog timer is the flag bit WDF that is set if the watchdog is allowed to time out. If the watchdog interrupt enable (WIE) bit in the interrupt register is set, a hardware interrupt on INT pin is also generated on watchdog timeout. The flag and the hardware interrupt are both cleared when user reads the flags registers.

Figure 3. Watchdog Timer Block Diagram

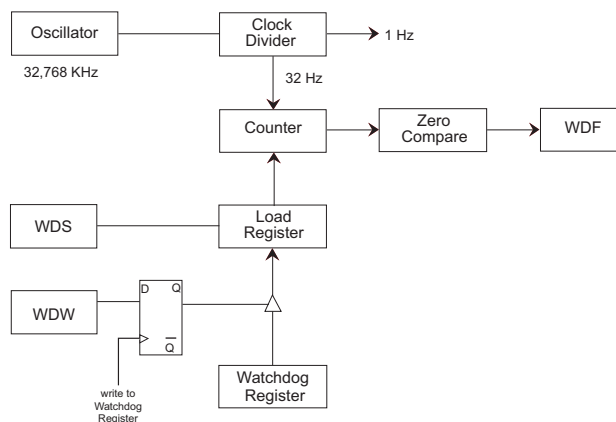

Power Monitor

The CY14B104K provides a power management scheme with power fail interrupt capability. It also controls the internal switch to backup power for the clock and protects the memory from low V_{CC} access. The power monitor is based on an internal band gap reference circuit that compares the V_{CC} voltage to V_{SWITCH} threshold.

As described in the section [AutoStore Operation on page 4](#), when V_{SWITCH} is reached as V_{CC} decays from power loss, a data STORE operation is initiated from SRAM to the nonvolatile elements, securing the last SRAM data state. Power is also switched from V_{CC} to the backup supply (battery or capacitor) to operate the RTC oscillator.

When operating from the backup source, read and write operations to nvSRAM are inhibited and the RTC functions are not available to the user. The RTC clock continues to operate in the background. The updated RTC time keeping registers data are available to the user after V_{CC} is restored to the device (see [AutoStore/Power-Up RECALL on page 22](#)).

Interrupts

The CY14B104K has flags register, interrupt register, and interrupt logic that can signal interrupt to the microcontroller. There are three potential sources for interrupt: watchdog timer, power monitor, and alarm timer. Each of these can be individually enabled to drive the INT pin by appropriate setting in the Interrupt register (0x7FFF6). In addition, each has an associated flag bit in the flags register (0x7FFF0) that the host processor uses to determine the cause of the interrupt. The INT pin driver has two bits that specify its behavior when an interrupt occurs.

An interrupt is raised only if both a flag is raised by one of the three sources and the respective interrupt enable bit in interrupts register is enabled (set to '1'). After an interrupt source is active, two programmable bits, H/L and P/L, determine the behavior of the output pin driver on INT pin. These two bits are located in the interrupt register and can be used to drive level or pulse mode output from the INT pin. In pulse mode, the pulse width is internally fixed at approximately 200 ms. This mode is intended to reset a host microcontroller. In the level mode, the pin goes to its active polarity until the flags register is read by the user. This mode is used as an interrupt to a host microcontroller. The control bits are summarized in the following section.

Interrupts are only generated while working on normal power and are not triggered when system is running in backup power mode.

Note CY14B104K generates valid interrupts only after the Power-up RECALL sequence is completed. All events on INT pin must be ignored for $t_{HRECALL}$ duration after powerup.

Interrupt Register

Watchdog Interrupt Enable (WIE): When set to '1', the watchdog timer drives the INT pin and an internal flag when a watchdog time out occurs. When WIE is set to '0', the watchdog timer only affects the WDF flag in flags register.

Alarm Interrupt Enable (AIE): When set to '1', the alarm match drives the INT pin and an internal flag. When AIE is set to '0', the alarm match only affects the AF flag in flags register.

Power Fail Interrupt Enable (PFE): When set to '1', the power fail monitor drives the pin and an internal flag. When PFE is set to '0', the power fail monitor only affects the PF flag in flags register.

High/Low (H/L): When set to a '1', the INT pin is active HIGH and the driver mode is push pull. The INT pin drives HIGH only when V_{CC} is greater than V_{SWITCH} . When set to a '0', the INT pin is active LOW and the drive mode is open drain. The INT pin must be pulled up to V_{CC} by a 10 k resistor while using the interrupt in active LOW mode.

Pulse/Level (P/L): When set to a '1' and an interrupt occurs, the INT pin is driven for approximately 200 ms. When P/L is set to a '0', the INT pin is driven HIGH or LOW (determined by H/L) until the flags register is read.

When an enabled interrupt source activates the INT pin, an external host reads the flags registers to determine the cause. Remember that all flags are cleared when the register is read. If the INT pin is programmed for Level mode, then the condition clears and the INT pin returns to its inactive state. If the pin is programmed for pulse mode, then reading the flag also clears the flag and the pin. The pulse does not complete its specified duration if the flags register is read. If the INT pin is used as a host reset, the flags register is not read during a reset.

Flags Register

The flags register has three flag bits: WDF, AF, and PF, which can be used to generate an interrupt. These flags are set by the watchdog timeout, alarm match, or power fail monitor respectively. The processor can either poll this register or enable interrupts when a flag is set. These flags are automatically reset when the register is read. The flags register is automatically loaded with the value 0x00 on power-up (except for the OSCF bit. See [Stopping and Starting the Oscillator on page 8](#)).

Figure 4. Interrupt Block Diagram

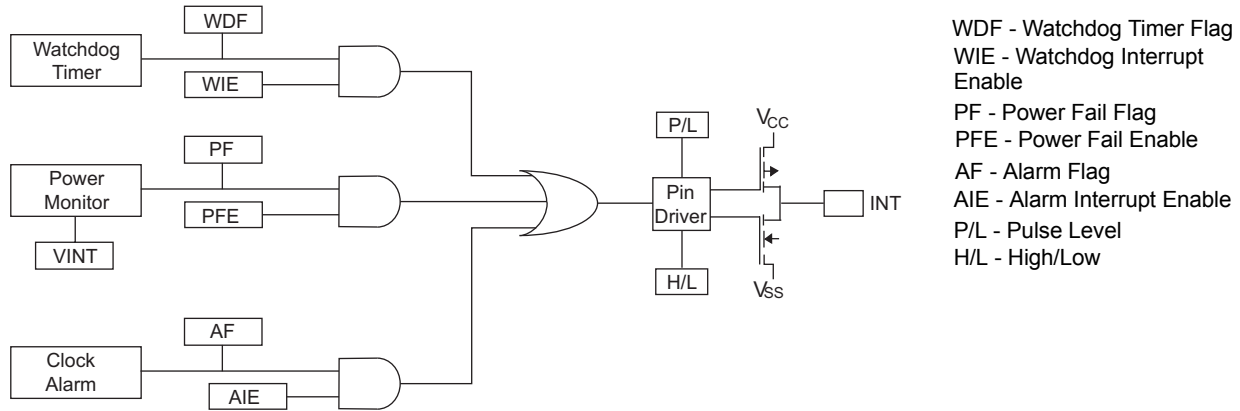

RTC External Components

The RTC requires connecting an external 32.768 kHz crystal and C₁, C₂ load capacitance as shown in the [Figure 5](#). The figure shows the recommended RTC external component values. The load capacitances C₁ and C₂ are inclusive of parasitic of the printed circuit board (PCB). The PCB parasitic includes the capacitance due to land pattern of crystal pads/pins, X_{in}/X_{out} pads and copper traces connecting crystal and device pins.

Figure 5. RTC Recommended Component Configuration^[10]

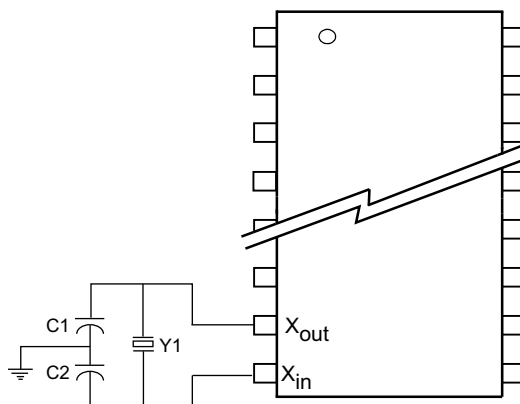

- Recommended Values**
Y₁ = 32.768 kHz (12.5 pF)
C₁ = 12 pF
C₂ = 69 pF

Note The recommended values for C₁ and C₂ include board trace capacitance.

Note

10. For nonvolatile static random access memory (nvSRAM) real time clock (RTC) design guidelines and best practices, see application note [AN61546](#).

PCB Design Considerations for RTC

RTC crystal oscillator is a low current circuit with high impedance nodes on their crystal pins. Due to lower timekeeping current of RTC, the crystal connections are very sensitive to noise on the board. Hence it is necessary to isolate the RTC circuit from other signals on the board.

It is also critical to minimize the stray capacitance on the PCB. Stray capacitances add to the overall crystal load capacitance and therefore cause oscillation frequency errors. Proper bypassing and careful layout are required to achieve the optimum RTC performance.

Layout requirements

The board layout must adhere to (but not limited to) the following guidelines during routing RTC circuitry. Following these guidelines help you achieve optimum performance from the RTC design.

- It is important to place the crystal as close as possible to the X_{in} and X_{out} pins. Keep the trace lengths between the crystal and RTC equal in length and as short as possible to reduce the probability of noise coupling by reducing the length of the antenna.

- Keep X_{in} and X_{out} trace width lesser than 8 mils. Wider trace width leads to larger trace capacitance. The larger these bond pads and traces are, the more likely it is that noise can couple from adjacent signals.
- Shield the X_{in} and X_{out} signals by providing a guard ring around the crystal circuitry. This guard ring prevents noise coupling from neighboring signals.
- Take care while routing any other high speed signal in the vicinity of RTC traces. The more the crystal is isolated from other signals on the board, the less likely it is that noise is coupled into the crystal. Maintain a minimum of 200 mil separation between the X_{in} , X_{out} traces and any other high speed signal on the board.
- No signals should run underneath crystal components on the same PCB layer.
- Create an isolated solid copper plane on adjacent PCB layer and underneath the crystal circuitry to prevent unwanted noise coupled from traces routed on the other signal layers of the PCB. The local plane should be separated by at least 40 mils from the neighboring plane on the same PCB layer. The solid plane should be in the vicinity of RTC components only and its perimeter should be kept equal to the guard ring perimeter. [Figure 6](#) shows the recommended layout for RTC circuit.

Figure 6. Recommended Layout for RTC

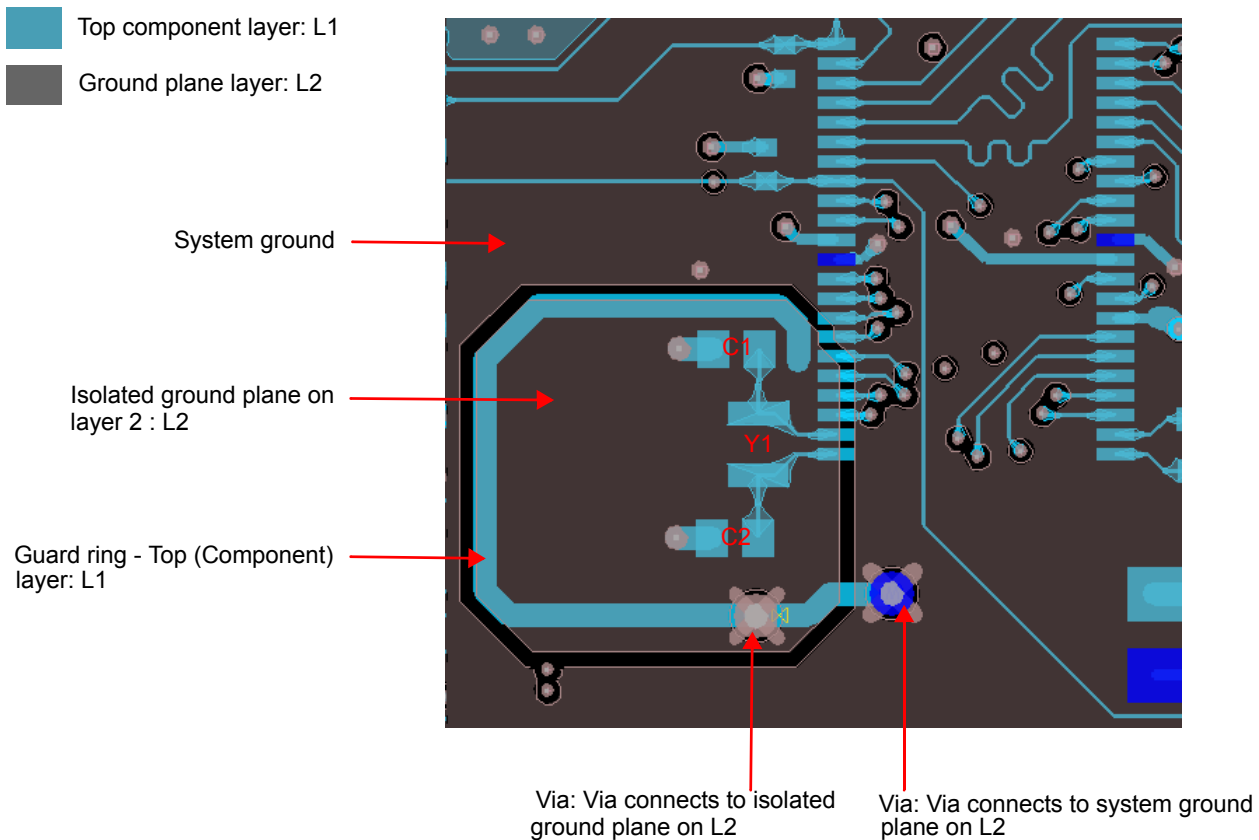

Table 3. RTC Register Map ^[11]

| Register | | BCD Format Data ^[12] | | | | | | | | Function/Range |
|-----------|-----------|---------------------------------|-------------------|------------------|----------------------|----------------|-------------|-------|------------------------------------|----------------------------|
| CY14B104K | CY14B104M | D7 | D6 | D5 | D4 | D3 | D2 | D1 | D0 | |
| 0x7FFFF | 0x3FFFF | 10s years | | | | Years | | | | Years: 00–99 |
| 0x7FFFE | 0x3FFFE | 0 | 0 | 0 | 10s months | Months | | | | Months: 01–12 |
| 0x7FFFD | 0x3FFFD | 0 | 0 | 10s day of month | | Day of month | | | | Day of month: 01–31 |
| 0x7FFFC | 0x3FFFC | 0 | 0 | 0 | 0 | 0 | Day of week | | | Day of week: 01–07 |
| 0x7FFFB | 0x3FFFB | 0 | 0 | 10s hours | | Hours | | | | Hours: 00–23 |
| 0x7FFFA | 0x3FFFA | 0 | 10s minutes | | | Minutes | | | | Minutes: 00–59 |
| 0x7FFF9 | 0x3FFF9 | 0 | 10s seconds | | | Seconds | | | | Seconds: 00–59 |
| 0x7FFF8 | 0x3FFF8 | OSCEN (0) | 0 | Cal sign (0) | Calibration (00000) | | | | Calibration values ^[13] | |
| 0x7FFF7 | 0x3FFF7 | WDS (0) | WDW (0) | WDT (000000) | | | | | | Watchdog ^[13] |
| 0x7FFF6 | 0x3FFF6 | WIE (0) | AIE (0) | PFE (0) | 0 | H/L (1) | P/L (0) | 0 | 0 | Interrupts ^[13] |
| 0x7FFF5 | 0x3FFF5 | M (1) | 0 | 10s alarm date | | Alarm day | | | | Alarm, day of month: 01–31 |
| 0x7FFF4 | 0x3FFF4 | M (1) | 0 | 10s alarm hours | | Alarm hours | | | | Alarm, hours: 00–23 |
| 0x7FFF3 | 0x3FFF3 | M (1) | 10s alarm minutes | | | Alarm minutes | | | | Alarm, minutes: 00–59 |
| 0x7FFF2 | 0x3FFF2 | M (1) | 10s alarm seconds | | | Alarm, seconds | | | | Alarm, seconds: 00–59 |
| 0x7FFF1 | 0x3FFF1 | 10s Centuries | | | | Centuries | | | | Centuries: 00–99 |
| 0x7FFF0 | 0x3FFF0 | WDF | AF | PF | OSCF ^[14] | 0 | CAL (0) | W (0) | R (0) | Flags ^[13] |

Notes

11. Upper byte D₁₅–D₈ (CY14B104M) of RTC registers are reserved for future use.
12. () designates values shipped from the factory.
13. This is a binary value, not a BCD value.
14. When user resets OSCF flag bit, the flags register will be updated after t_{RTCp} time.

Table 4. Register Map Detail

| Register | | Description | | | | | | | |
|-----------|-----------|--|-------------|------------------|-----------|--------------|-------------|----|----|
| CY14B104K | CY14B104M | | | | | | | | |
| 0x7FFFF | 0x3FFFF | Time Keeping - Years | | | | | | | |
| | | D7 | D6 | D5 | D4 | D3 | D2 | D1 | D0 |
| | | 10s years | | | | Years | | | |
| | | Contains the lower two BCD digits of the year. Lower nibble (four bits) contains the value for years; upper nibble (four bits) contains the value for 10s of years. Each nibble operates from 0 to 9. The range for the register is 0–99. | | | | | | | |
| 0x7FFFE | 0x3FFFE | Time Keeping - Months | | | | | | | |
| | | D7 | D6 | D5 | D4 | D3 | D2 | D1 | D0 |
| | | 0 | 0 | 0 | 10s month | Months | | | |
| | | Contains the BCD digits of the month. Lower nibble (four bits) contains the lower digit and operates from 0 to 9; upper nibble (one bit) contains the upper digit and operates from 0 to 1. The range for the register is 1–12. | | | | | | | |
| 0x7FFFD | 0x3FFFD | Time Keeping - Date | | | | | | | |
| | | D7 | D6 | D5 | D4 | D3 | D2 | D1 | D0 |
| | | 0 | 0 | 10s day of month | | Day of month | | | |
| | | Contains the BCD digits for the date of the month. Lower nibble (four bits) contains the lower digit and operates from 0 to 9; upper nibble (two bits) contains the 10s digit and operates from 0 to 3. The range for the register is 1–31. Leap years are automatically adjusted for. | | | | | | | |
| 0x7FFFC | 0x3FFFC | Time Keeping - Day | | | | | | | |
| | | D7 | D6 | D5 | D4 | D3 | D2 | D1 | D0 |
| | | 0 | 0 | 0 | 0 | 0 | Day of week | | |
| | | Lower nibble (three bits) contains a value that correlates to day of the week. Day of the week is a ring counter that counts from 1 to 7 then returns to 1. The user must assign meaning to the day value, because the day is not integrated with the date. | | | | | | | |
| 0x7FFFB | 0x3FFFB | Time Keeping - Hours | | | | | | | |
| | | D7 | D6 | D5 | D4 | D3 | D2 | D1 | D0 |
| | | 0 | 0 | 10s hours | | Hours | | | |
| | | Contains the BCD value of hours in 24 hour format. Lower nibble (four bits) contains the lower digit and operates from 0 to 9; upper nibble (two bits) contains the upper digit and operates from 0 to 2. The range for the register is 0–23. | | | | | | | |
| 0x7FFFA | 0x3FFFA | Time Keeping - Minutes | | | | | | | |
| | | D7 | D6 | D5 | D4 | D3 | D2 | D1 | D0 |
| | | 0 | 10s minutes | | | Minutes | | | |
| | | Contains the BCD value of minutes. Lower nibble (four bits) contains the lower digit and operates from 0 to 9; upper nibble (three bits) contains the upper minutes digit and operates from 0 to 5. The range for the register is 0–59. | | | | | | | |
| 0x7FFF9 | 0x3FFF9 | Time Keeping - Seconds | | | | | | | |
| | | D7 | D6 | D5 | D4 | D3 | D2 | D1 | D0 |
| | | 0 | 10s seconds | | | Seconds | | | |
| | | Contains the BCD value of seconds. Lower nibble (four bits) contains the lower digit and operates from 0 to 9; upper nibble (three bits) contains the upper digit and operates from 0 to 5. The range for the register is 0–59. | | | | | | | |

Table 4. Register Map Detail (continued)

| Register | | Description | | | | | | | |
|------------------|-----------|--|-----|------------------|-------------|-----|------------|----|----|
| CY14B104K | CY14B104M | | | | | | | | |
| 0x7FFF8 | 0x3FFF8 | Calibration/Control | | | | | | | |
| | | D7 | D6 | D5 | D4 | D3 | D2 | D1 | D0 |
| | | OSCEN | 0 | Calibration sign | Calibration | | | | |
| OSCEN | | Oscillator enable. When set to '1', the oscillator is stopped. When set to '0', the oscillator runs. Disabling the oscillator saves battery or capacitor power during storage. | | | | | | | |
| Calibration Sign | | Determines if the calibration adjustment is applied as an addition (1) to or as a subtraction (0) from the time-base. | | | | | | | |
| Calibration | | These five bits control the calibration of the clock. | | | | | | | |
| 0x7FFF7 | 0x3FFF7 | WatchDog Timer | | | | | | | |
| | | D7 | D6 | D5 | D4 | D3 | D2 | D1 | D0 |
| | | WDS | WDW | WDT | | | | | |
| WDS | | Watchdog strobe. Setting this bit to '1' reloads and restarts the watchdog timer. Setting the bit to '0' has no effect. The bit is cleared automatically after the watchdog timer is reset. The WDS bit is write only. Reading it always returns a '0'. | | | | | | | |
| WDW | | Watchdog write enable. Setting this bit to 1 disables any WRITE to the watchdog timeout value (D5–D0). This allows the user to set the watchdog strobe bit without disturbing the timeout value. Setting this bit to 0 allows bits D5–D0 to be written to the watchdog register when the next write cycle is complete. This function is explained in more detail in Watchdog Timer on page 8 . | | | | | | | |
| WDT | | Watchdog timeout selection. The watchdog timer interval is selected by the 6-bit value in this register. It represents a multiplier of the 32 Hz count (31.25 ms). The range of timeout value is 31.25 ms (a setting of '1') to 2 seconds (setting of 3 Fh). Setting the watchdog timer register to '0' disables the timer. These bits can be written only if the WDW bit was set to 0 on a previous cycle. | | | | | | | |
| 0x7FFF6 | 0x3FFF6 | Interrupt Status/Control | | | | | | | |
| | | D7 | D6 | D5 | D4 | D3 | D2 | D1 | D0 |
| | | WIE | AIE | PFE | 0 | H/L | P/L | 0 | 0 |
| WIE | | Watchdog interrupt enable. When set to '1' and a watchdog timeout occurs, the watchdog timer drives the INT pin and the WDF flag. When set to '0', the watchdog timeout affects only the WDF flag. | | | | | | | |
| AIE | | Alarm interrupt enable. When set to '1', the alarm match drives the INT pin and the AF flag. When set to '0', the alarm match only affects the AF flag. | | | | | | | |
| PFE | | Power fail enable. When set to '1', the power fail monitor drives the INT pin and the PF flag. When set to '0', the power fail monitor affects only the PF flag. | | | | | | | |
| 0 | | Reserved for future use | | | | | | | |
| H/L | | High/Low. When set to '1', the INT pin is driven active HIGH. When set to '0,' the INT pin is open drain, active LOW. | | | | | | | |
| P/L | | Pulse/Level. When set to 1, the INT pin is driven active (determined by H/L) by an interrupt source for approximately 200 ms. When set to 0, the INT pin is driven to an active level (as set by H/L) until the flags register is read. | | | | | | | |
| 0x7FFF5 | 0x3FFF5 | Alarm - Day | | | | | | | |
| | | D7 | D6 | D5 | D4 | D3 | D2 | D1 | D0 |
| | | M | 0 | 10s alarm date | | | Alarm date | | |
| | | Contains the alarm value for the date of the month and the mask bit to select or deselect the date value. | | | | | | | |
| M | | Match. When this bit is set to '0', the date value is used in the alarm match. Setting this bit to '1' causes the match circuit to ignore the date value. | | | | | | | |

Table 4. Register Map Detail (continued)

| Register | | Description | | | | | | | |
|-----------|--|--|-------------------|-----------------|------|---------------|-------------|----|----|
| CY14B104K | CY14B104M | | | | | | | | |
| 0x7FFF4 | 0x3FFF4 | Alarm - Hours | | | | | | | |
| | | D7 | D6 | D5 | D4 | D3 | D2 | D1 | D0 |
| | | M | 0 | 10s alarm hours | | | Alarm hours | | |
| | | Contains the alarm value for the hours and the mask bit to select or deselect the hours value. | | | | | | | |
| M | | Match. When this bit is set to '0', the hours value is used in the alarm match. Setting this bit to '1' causes the match circuit to ignore the hours value. | | | | | | | |
| 0x7FFF3 | 0x3FFF3 | Alarm - Minutes | | | | | | | |
| | | D7 | D6 | D5 | D4 | D3 | D2 | D1 | D0 |
| | | M | 10s alarm minutes | | | Alarm minutes | | | |
| | | Contains the alarm value for the minutes and the mask bit to select or deselect the minutes value. | | | | | | | |
| M | | Match. When this bit is set to '0', the minutes value is used in the alarm match. Setting this bit to '1' causes the match circuit to ignore the minutes value. | | | | | | | |
| 0x7FFF2 | 0x3FFF2 | Alarm - Seconds | | | | | | | |
| | | D7 | D6 | D5 | D4 | D3 | D2 | D1 | D0 |
| | | M | 10s alarm seconds | | | Alarm seconds | | | |
| | | Contains the alarm value for the seconds and the mask bit to select or deselect the seconds' value. | | | | | | | |
| M | | Match. When this bit is set to '0', the seconds value is used in the alarm match. Setting this bit to '1' causes the match circuit to ignore the seconds value. | | | | | | | |
| 0x7FFF1 | 0x3FFF1 | Time Keeping - Centuries | | | | | | | |
| | | D7 | D6 | D5 | D4 | D3 | D2 | D1 | D0 |
| | | 10s centuries | | | | Centuries | | | |
| | | Contains the BCD value of centuries. Lower nibble contains the lower digit and operates from 0 to 9; upper nibble contains the upper digit and operates from 0 to 9. The range for the register is 0-99 centuries. | | | | | | | |
| 0x7FFF0 | 0x3FFF0 | Flags | | | | | | | |
| | | D7 | D6 | D5 | D4 | D3 | D2 | D1 | D0 |
| | | WDF | AF | PF | OSCF | 0 | CAL | W | R |
| WDF | Watchdog timer flag. This read only bit is set to '1' when the watchdog timer is allowed to reach 0 without being reset by the user. It is cleared to 0 when the flags register is read or on power-up. | | | | | | | | |
| AF | Alarm flag. This read only bit is set to '1' when the time and date match the values stored in the alarm registers with the match bits = 0. It is cleared when the flags register is read or on power-up. | | | | | | | | |
| PF | Power fail flag. This read only bit is set to '1' when power falls below the power fail threshold V_{SWITCH} . It is cleared to 0 when the flags register is read or on power-up. | | | | | | | | |
| OSCF | Oscillator fail flag. Set to '1' on power-up if the oscillator is enabled and not running in the first 5 ms of operation. This indicates that RTC backup power failed and clock value is no longer valid. This bit survives the power cycle and is never cleared internally by the chip. The user must check for this condition and write '0' to clear this flag. When user resets OSCF flag bit, the bit will be updated after t_{RTCp} time. | | | | | | | | |
| CAL | Calibration mode. When set to '1', a 512 Hz square wave is output on the INT pin. When set to '0', the INT pin resumes normal operation. This bit defaults to 0 (disabled) on power-up. | | | | | | | | |
| W | Write enable: Setting the 'W' bit to '1' freezes updates of the RTC registers. The user can then write to RTC registers, alarm registers, calibration register, interrupt register and flags register. Setting the 'W' bit to '0' causes the contents of the RTC registers to be transferred to the time keeping counters if the time has changed. This transfer process takes t_{RTCp} time to complete. This bit defaults to 0 on power-up. | | | | | | | | |
| R | Read enable: Setting 'R' bit to '1', stops clock updates to user RTC registers so that clock updates are not seen during the reading process. Set 'R' bit to '0' to resume clock updates to the holding register. Setting this bit does not require 'W' bit to be set to '1'. This bit defaults to 0 on power-up. | | | | | | | | |

Maximum Ratings

Exceeding maximum ratings may impair the useful life of the device. These user guidelines are not tested.

| | |
|---|----------------------------|
| Storage temperature | -65 °C to +150 °C |
| Maximum accumulated storage time | |
| At 150 °C ambient temperature | 1000 h |
| At 85 °C ambient temperature | 20 Years |
| Maximum junction temperature | 150 °C |
| Supply voltage on V_{CC} relative to V_{SS} | -0.5 V to 4.1 V |
| Voltage applied to outputs in High Z state | -0.5 V to $V_{CC} + 0.5$ V |
| Input voltage | -0.5 V to $V_{CC} + 0.5$ V |

| | |
|--|----------------------------|
| Transient voltage (< 20 ns) on any pin to ground potential | -2.0 V to $V_{CC} + 2.0$ V |
| Package power dissipation capability ($T_A = 25$ °C) | 1.0 W |
| Surface mount Pb soldering temperature (3 Seconds) | +260 °C |
| DC output current (1 output at a time, 1s duration) | 15 mA |
| Static discharge voltage (per MIL-STD-883, Method 3015) | > 2001 V |
| Latch up current | > 200 mA |

Operating Range

| Range | Ambient Temperature | V_{CC} |
|------------|---------------------|----------------|
| Industrial | -40 °C to +85 °C | 2.7 V to 3.6 V |

DC Electrical Characteristics

Over the [Operating Range](#)

| Parameter | Description | Test Conditions | Min | Typ ^[15] | Max | Unit |
|--------------------------|--|---|----------------|---------------------|----------------|----------|
| V_{CC} | Power supply | | 2.7 | 3.0 | 3.6 | V |
| I_{CC1} | Average V_{CC} current | $t_{RC} = 25$ ns $t_{RC} = 45$ ns Values obtained without output loads ($I_{OUT} = 0$ mA) | - | - | 70 52 | mA mA |
| I_{CC2} | Average V_{CC} current during STORE | All inputs don't care, $V_{CC} = \text{Max}$. Average current for duration t_{STORE} | - | - | 10 | mA |
| I_{CC3} | Average V_{CC} current at $t_{RC} = 200$ ns, $V_{CC(Typ)}$, 25 °C | All inputs cycling at CMOS levels. Values obtained without output loads ($I_{OUT} = 0$ mA). | - | 35 | - | mA |
| I_{CC4} | Average V_{CAP} current during AutoStore cycle | All inputs don't care. Average current for duration t_{STORE} | - | - | 5 | mA |
| I_{SB} | V_{CC} standby current | $CE \geq (V_{CC} - 0.2$ V). $V_{IN} \leq 0.2$ V or $\geq (V_{CC} - 0.2$ V). W bit set to '0'. Standby current level after nonvolatile cycle is complete. Inputs are static. $f = 0$ MHz. | - | - | 5 | mA |
| I_{IX} ^[16] | Input leakage current (except HSB) | $V_{CC} = \text{Max}$, $V_{SS} \leq V_{IN} \leq V_{CC}$ | -1 | - | +1 | μ A |
| | Input leakage current (for HSB) | $V_{CC} = \text{Max}$, $V_{SS} \leq V_{IN} \leq V_{CC}$ | -100 | - | +1 | μ A |
| I_{OZ} | Off state output leakage current | $V_{CC} = \text{Max}$, $V_{SS} \leq V_{OUT} \leq V_{CC}$, CE or $OE \geq V_{IH}$ or $BHE/BLE \geq V_{IH}$ or $WE \leq V_{IL}$ | -1 | - | +1 | μ A |
| V_{IH} | Input HIGH voltage | | 2.0 | - | $V_{CC} + 0.5$ | V |
| V_{IL} | Input LOW voltage | | $V_{SS} - 0.5$ | - | 0.8 | V |
| V_{OH} | Output HIGH voltage | $I_{OUT} = -2$ mA | 2.4 | - | - | V |
| V_{OL} | Output LOW voltage | $I_{OUT} = 4$ mA | - | - | 0.4 | V |

Notes

15. Typical values are at 25 °C, $V_{CC} = V_{CC(Typ)}$. Not 100% tested.

16. The HSB pin has $I_{OUT} = -2$ μ A for V_{OH} of 2.4 V when both active HIGH and LOW drivers are disabled. When they are enabled standard V_{OH} and V_{OL} are valid. This parameter is characterized but not tested.

DC Electrical Characteristics (continued)

Over the [Operating Range](#)

| Parameter | Description | Test Conditions | Min | Typ ^[15] | Max | Unit |
|-----------------------|---|------------------------------------|-----|---------------------|----------|---------------|
| $V_{CAP}^{[17]}$ | Storage capacitor | Between V_{CAP} pin and V_{SS} | 61 | 68 | 180 | μF |
| $V_{VCAP}^{[18, 19]}$ | Maximum voltage driven on V_{CAP} pin by the device | $V_{CC} = \text{Max}$ | – | – | V_{CC} | V |

Data Retention and Endurance

Over the [Operating Range](#)

| Parameter | Description | Min | Unit |
|-----------------|------------------------------|-------|-------|
| DATA_R | Data retention | 20 | Years |
| NV_C | Nonvolatile STORE operations | 1,000 | K |

Capacitance

| Parameter ^[19] | Description | Test Conditions | Max | Unit |
|---------------------------|---|---|-----|-------------|
| C_{IN} | Input capacitance (except BHE, BLE and HSB) | $T_A = 25\text{ }^\circ\text{C}$, $f = 1\text{ MHz}$, $V_{CC} = V_{CC(\text{Typ})}$ | 7 | pF |
| | Input capacitance (for BHE, BLE and HSB) | | 8 | pF |
| C_{OUT} | Output capacitance (except HSB) | | 7 | pF |
| | Output capacitance (for HSB) | | 8 | pF |

Thermal Resistance

| Parameter ^[19] | Description | Test Conditions | 44-pin TSOP II | 54-pin TSOP II | Unit |
|---------------------------|--|---|----------------|----------------|--------------------|
| Θ_{JA} | Thermal resistance (junction to ambient) | Test conditions follow standard test methods and procedures for measuring thermal impedance, in accordance with EIA/JESD51. | 43.3 | 42.03 | $^\circ\text{C/W}$ |
| Θ_{JC} | Thermal resistance (junction to case) | | 5.56 | 6.08 | $^\circ\text{C/W}$ |

Notes

17. Min V_{CAP} value guarantees that there is a sufficient charge available to complete a successful AutoStore operation. Max V_{CAP} value guarantees that the capacitor on V_{CAP} is charged to a minimum voltage during a Power-Up RECALL cycle so that an immediate power-down cycle can complete a successful AutoStore. Therefore it is always recommended to use a capacitor within the specified min and max limits. Refer application note [AN43593](#) for more details on V_{CAP} options.
18. Maximum voltage on V_{CAP} pin (V_{VCAP}) is provided for guidance when choosing the V_{CAP} capacitor. The voltage rating of the V_{CAP} capacitor across the operating temperature range should be higher than the V_{VCAP} voltage.
19. These parameters are guaranteed by design and are not tested.

AC Test Loads

Figure 7. AC Test Loads

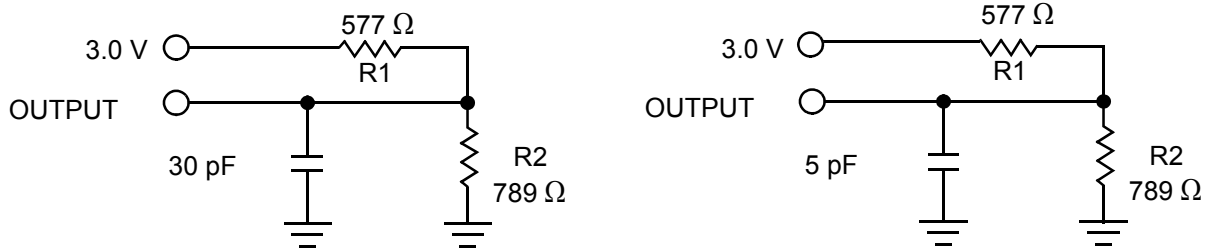

AC Test Conditions

Input pulse levels.....0 V to 3 V
 Input rise and fall times (10%–90%)..... ≤ 3 ns
 Input and output timing reference levels..... 1.5 V

RTC Characteristics

Over the [Operating Range](#)

| Parameters | Description | Min | Typ ^[20] | Max | Units | |
|-------------------------------------|--|----------------------|---------------------|------|-------|----|
| V _{RTCbat} | RTC battery pin voltage | 1.8 | 3.0 | 3.6 | V | |
| I _{BAK} ^[21] | RTC backup current (Refer Figure 5 for the recommended external components for RTC) | T _A (Min) | – | – | 0.35 | μA |
| | | 25 °C | – | 0.35 | – | μA |
| | | T _A (Max) | – | – | 0.5 | μA |
| V _{RTCcap} ^[22] | RTC capacitor pin voltage | T _A (Min) | 1.6 | – | 3.6 | V |
| | | 25 °C | 1.5 | 3.0 | 3.6 | V |
| | | T _A (Max) | 1.4 | – | 3.6 | V |
| t _{OCS} | RTC oscillator time to start | – | 1 | 2 | sec | |
| t _{RTCp} | RTC processing time from end of ‘W’ bit set to ‘0’ | – | – | 350 | μs | |
| R _{BKCHG} | RTC backup capacitor charge current-limiting resistor | 350 | – | 850 | Ω | |

Notes

20. Typical values are at 25 °C, V_{CC} = V_{CC(Typ)}. Not 100% tested.

21. From either V_{RTCcap} or V_{RTCbat}.

22. If V_{RTCcap} > 0.5 V or if no capacitor is connected to V_{RTCcap} pin, the oscillator starts in t_{OCS} time. If a backup capacitor is connected and V_{RTCcap} < 0.5 V, the capacitor must be allowed to charge to 0.5 V for oscillator to start.

AC Switching Characteristics

Over the [Operating Range](#)

| Parameters ^[23] | | Description | 25 ns | | 45 ns | | Unit |
|----------------------------|---------------|-----------------------------------|-------|-----|-------|-----|------|
| Cypress Parameter | Alt Parameter | | Min | Max | Min | Max | |
| SRAM Read Cycle | | | | | | | |
| t_{ACE} | t_{ACS} | Chip enable access time | – | 25 | – | 45 | ns |
| $t_{RC}^{[24]}$ | t_{RC} | Read cycle time | 25 | – | 45 | – | ns |
| $t_{AA}^{[25]}$ | t_{AA} | Address access time | – | 25 | – | 45 | ns |
| t_{DOE} | t_{OE} | Output enable to data valid | – | 12 | – | 20 | ns |
| $t_{OHA}^{[25]}$ | t_{OH} | Output hold after address change | 3 | – | 3 | – | ns |
| $t_{LZCE}^{[26, 27]}$ | t_{LZ} | Chip enable to output active | 3 | – | 3 | – | ns |
| $t_{HZCE}^{[26, 27]}$ | t_{HZ} | Chip disable to output inactive | – | 10 | – | 15 | ns |
| $t_{LZOE}^{[26, 27]}$ | t_{OLZ} | Output enable to output active | 0 | – | 0 | – | ns |
| $t_{HZOE}^{[26, 27]}$ | t_{OHZ} | Output disable to output inactive | – | 10 | – | 15 | ns |
| $t_{PU}^{[26]}$ | t_{PA} | Chip enable to power active | 0 | – | 0 | – | ns |
| $t_{PD}^{[26]}$ | t_{PS} | Chip disable to power standby | – | 25 | – | 45 | ns |
| t_{DBE} | – | Byte enable to data valid | – | 12 | – | 20 | ns |
| $t_{LZBE}^{[26]}$ | – | Byte enable to output active | 0 | – | 0 | – | ns |
| $t_{HZBE}^{[26]}$ | – | Byte disable to output inactive | – | 10 | – | 15 | ns |
| SRAM Write Cycle | | | | | | | |
| t_{WC} | t_{WC} | Write cycle time | 25 | – | 45 | – | ns |
| t_{PWE} | t_{WP} | Write pulse width | 20 | – | 30 | – | ns |
| t_{SCE} | t_{CW} | Chip enable to end of write | 20 | – | 30 | – | ns |
| t_{SD} | t_{DW} | Data setup to end of write | 10 | – | 15 | – | ns |
| t_{HD} | t_{DH} | Data hold after end of write | 0 | – | 0 | – | ns |
| t_{AW} | t_{AW} | Address setup to end of write | 20 | – | 30 | – | ns |
| t_{SA} | t_{AS} | Address setup to start of write | 0 | – | 0 | – | ns |
| t_{HA} | t_{WR} | Address hold after end of write | 0 | – | 0 | – | ns |
| $t_{HZWE}^{[26, 27, 28]}$ | t_{WZ} | Write enable to output disable | – | 10 | – | 15 | ns |
| $t_{LZWE}^{[26, 27]}$ | t_{OW} | Output active after end of write | 3 | – | 3 | – | ns |
| t_{BW} | – | Byte enable to end of write | 20 | – | 30 | – | ns |

Switching Waveforms

Figure 8. SRAM Read Cycle 1 (Address Controlled) ^[24, 25, 29]

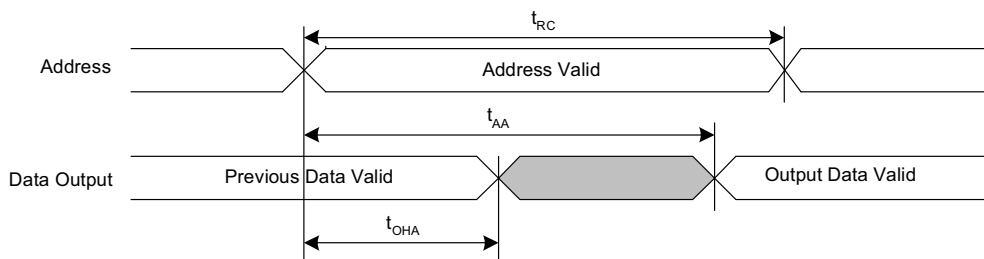

Notes

23. Test conditions assume signal transition time of 3 ns or less, timing reference levels of $V_{CC}/2$, input pulse levels of 0 to $V_{CC(typ)}$, and output loading of the specified I_{OL}/I_{OH} and load capacitance shown in [Figure 7 on page 18](#).
24. WE must be HIGH during SRAM read cycles.
25. Device is continuously selected with CE, OE and BHE / BLE LOW.
26. These parameters are only guaranteed by design and are not tested.
27. Measured ± 200 mV from steady state output voltage.
28. If WE is LOW when CE goes LOW, the outputs remain in the high impedance state.
29. HSB must remain HIGH during read and write cycles.

Switching Waveforms (continued)

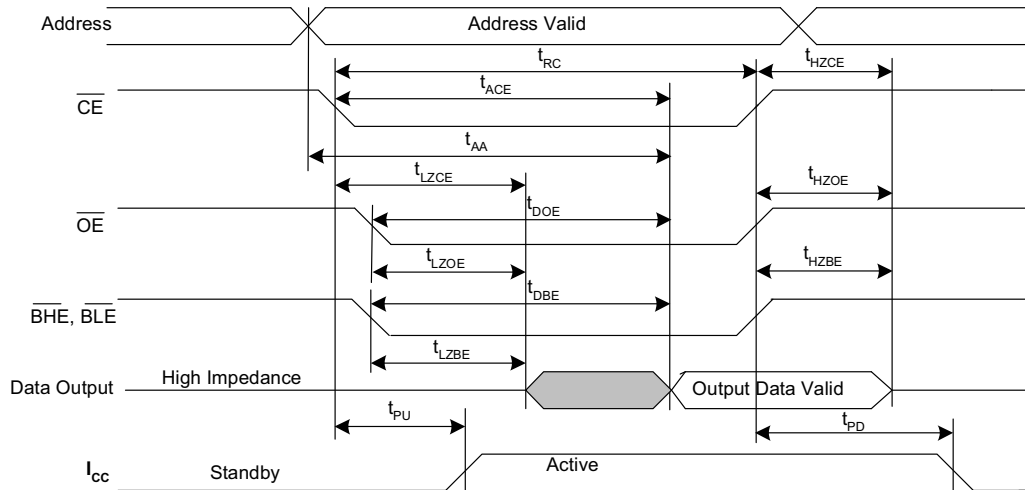
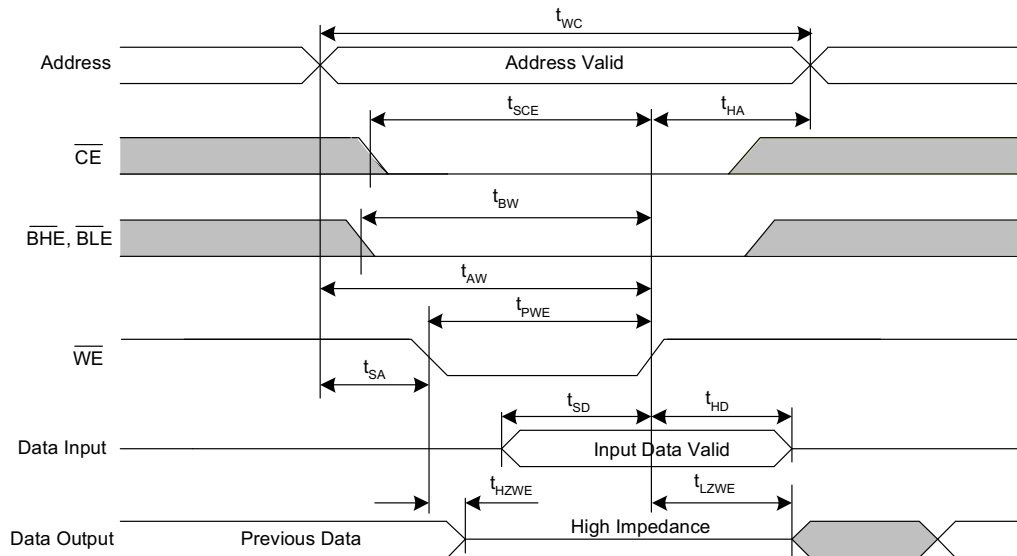
Figure 9. SRAM Read Cycle 2 ($\overline{\text{CE}}$ and $\overline{\text{OE}}$ Controlled) [30, 31, 32]

Figure 10. SRAM Write Cycle 1 ($\overline{\text{WE}}$ Controlled) [30, 32, 33, 34]

Notes

30. BHE and BLE are applicable for $\times 16$ configuration only.
31. $\overline{\text{WE}}$ must be HIGH during SRAM read cycles.
32. HSB must remain HIGH during read and write cycles.
33. If $\overline{\text{WE}}$ is LOW when $\overline{\text{CE}}$ goes LOW, the outputs remain in the high impedance state.
34. $\overline{\text{CE}}$ or $\overline{\text{WE}}$ must be $\geq V_{\text{IH}}$ during address transitions.

Switching Waveforms (continued)

Figure 11. SRAM Write Cycle 2 ($\overline{\text{CE}}$ Controlled) [35, 36, 37, 38]

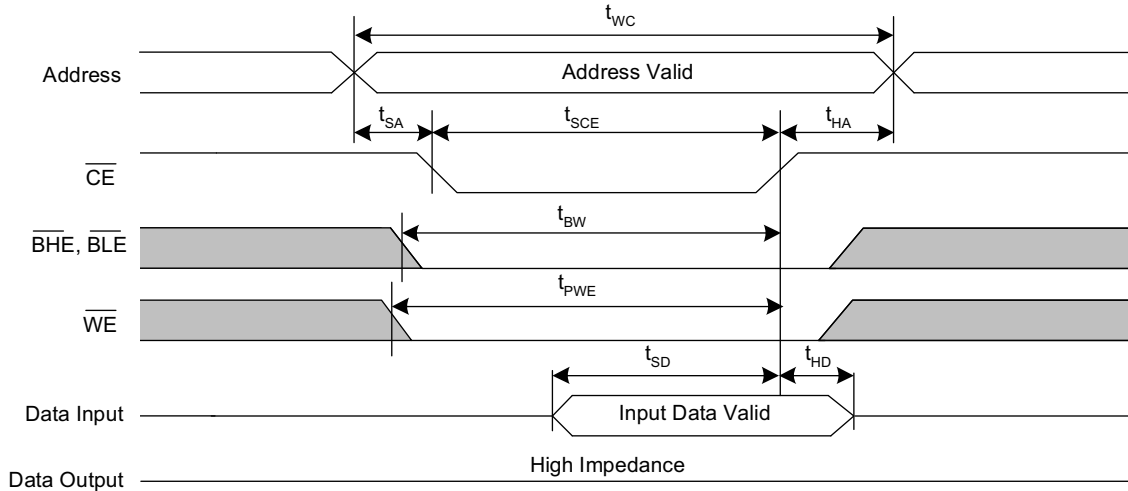
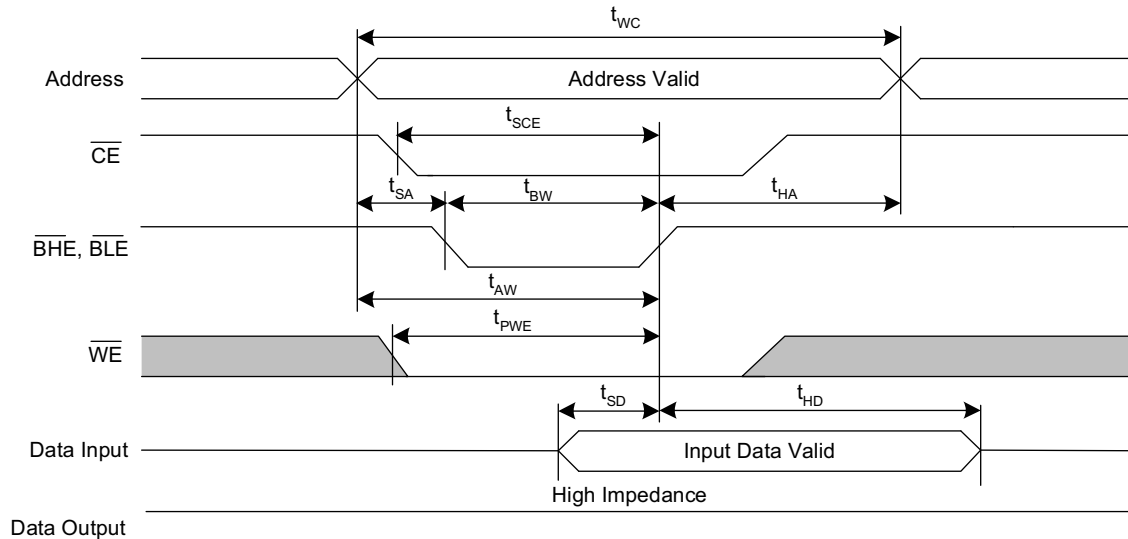

Figure 12. SRAM Write Cycle 3 ($\overline{\text{BHE}}$ and $\overline{\text{BLE}}$ Controlled) [36, 37, 38, 39, 40]

(Not applicable for RTC register writes)



Notes

- 35. $\overline{\text{BHE}}$ and $\overline{\text{BLE}}$ are applicable for $\times 16$ configuration only.
- 36. If $\overline{\text{WE}}$ is LOW when $\overline{\text{CE}}$ goes LOW, the outputs remain in the high impedance state.
- 37. $\overline{\text{HSB}}$ must remain HIGH during read and write cycles.
- 38. $\overline{\text{CE}}$ or $\overline{\text{WE}}$ must be $\geq V_{IH}$ during address transitions.
- 39. While there are 19 address lines on the CY14B104K (18 address lines on the CY14B104M), only 13 address lines ($A_{14}-A_2$) are used to control software modes. The remaining address lines are don't care.
- 40. Only $\overline{\text{CE}}$ and $\overline{\text{WE}}$ controlled writes to RTC registers are allowed. $\overline{\text{BLE}}$ pin must be held LOW before $\overline{\text{CE}}$ or $\overline{\text{WE}}$ pin goes LOW for writes to RTC register.

AutoStore/Power-Up RECALL

Over the [Operating Range](#)

| Parameter | Description | CY14B104K/CY14B104M | | Unit |
|-----------------------|---|---------------------|------|---------|
| | | Min | Max | |
| $t_{HRECALL}^{[41]}$ | Power-Up RECALL duration | – | 20 | ms |
| $t_{STORE}^{[42]}$ | STORE cycle duration | – | 8 | ms |
| $t_{DELAY}^{[43]}$ | Time allowed to complete SRAM write cycle | – | 25 | ns |
| V_{SWITCH} | Low-voltage trigger level | – | 2.65 | V |
| $t_{VCCRRISE}^{[44]}$ | V_{CC} rise time | 150 | – | μ s |
| $V_{HDIS}^{[44]}$ | HSB output disable voltage | – | 1.9 | V |
| $t_{LZHSB}^{[44]}$ | HSB to output active time | – | 5 | μ s |
| $t_{HHHD}^{[44]}$ | HSB High active time | – | 500 | ns |

Switching Waveforms – AutoStore/Power-up RECALL

Figure 13. AutoStore or Power-Up RECALL^[45]

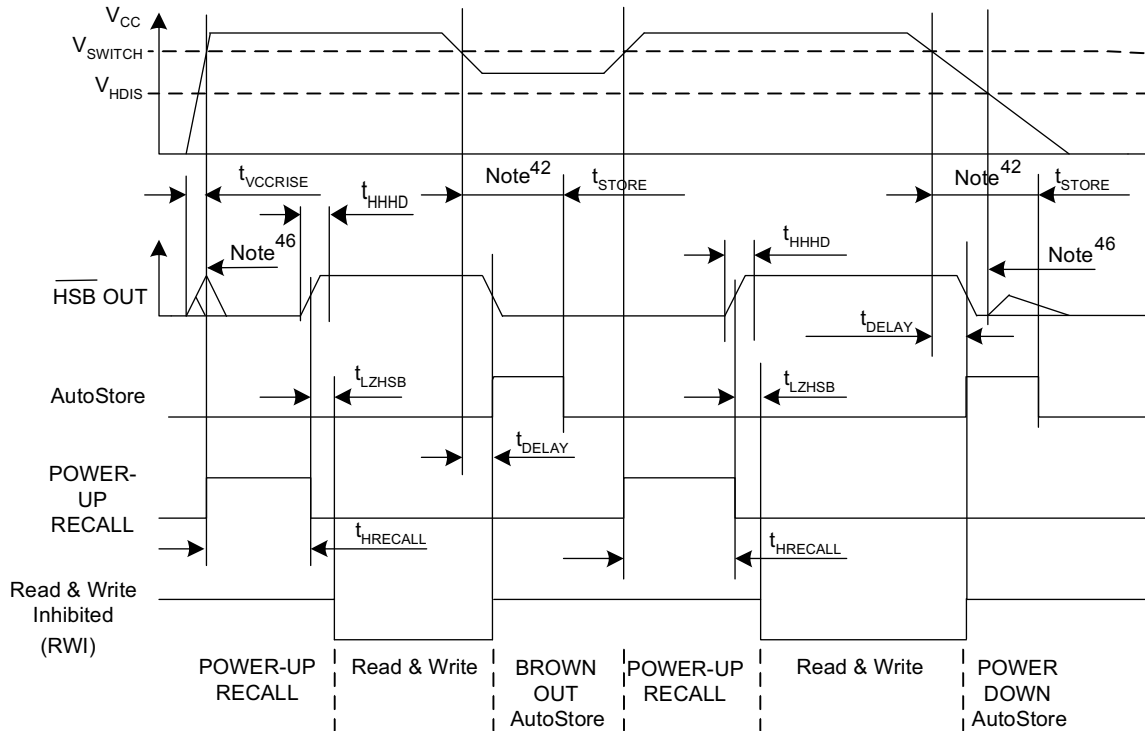

Notes

- 41. $t_{HRECALL}$ starts from the time V_{CC} rises above V_{SWITCH} .
- 42. If an SRAM write has not taken place since the last nonvolatile cycle, no AutoStore or Hardware STORE takes place.
- 43. On a Hardware STORE and AutoStore initiation, SRAM write operation continues to be enabled for time t_{DELAY} .
- 44. These parameters are only guaranteed by design and are not tested.
- 45. Read and write cycles are ignored during STORE, RECALL, and while V_{CC} is below V_{SWITCH} .
- 46. During power-up and power-down, HSB glitches when HSB pin is pulled up through an external resistor.

Software Controlled STORE and RECALL Cycle

Over the [Operating Range](#)

| Parameter [47, 48] | Description | 25 ns | | 45 ns | | Unit |
|--------------------|------------------------------------|-------|-----|-------|-----|---------|
| | | Min | Max | Min | Max | |
| t_{RC} | STORE/RECALL initiation cycle time | 25 | – | 45 | – | ns |
| t_{SA} | Address setup time | 0 | – | 0 | – | ns |
| t_{CW} | Clock pulse width | 20 | – | 30 | – | ns |
| t_{HA} | Address hold time | 0 | – | 0 | – | ns |
| t_{RECALL} | RECALL duration | – | 200 | – | 200 | μ s |
| t_{SS} [49, 50] | Soft sequence processing time | – | 100 | – | 100 | μ s |

Switching Waveforms – Software Controlled STORE/RECALL Cycle

Figure 14. \overline{CE} and \overline{OE} Controlled Software STORE and RECALL Cycle [48]

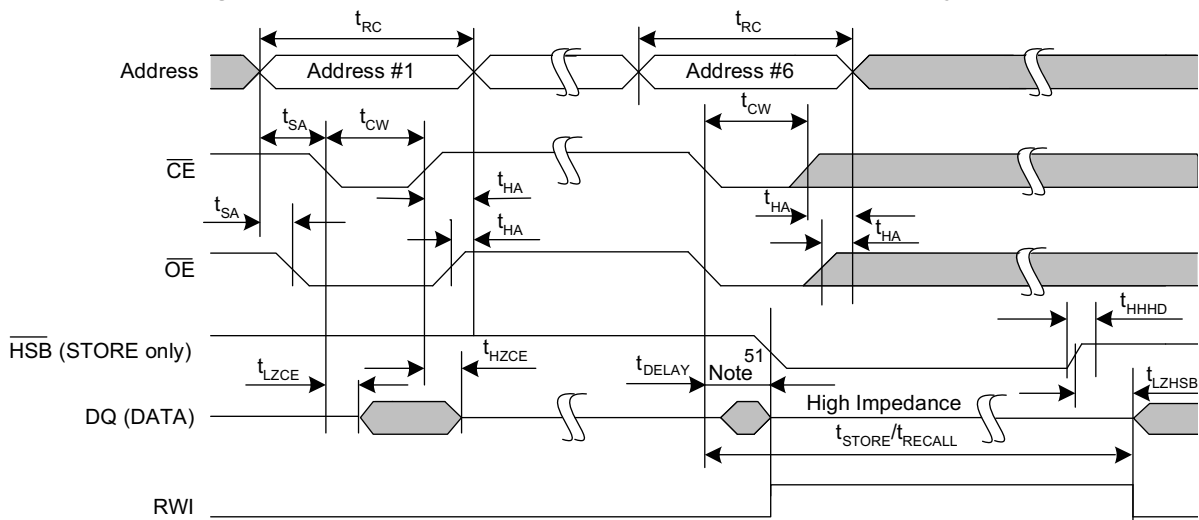
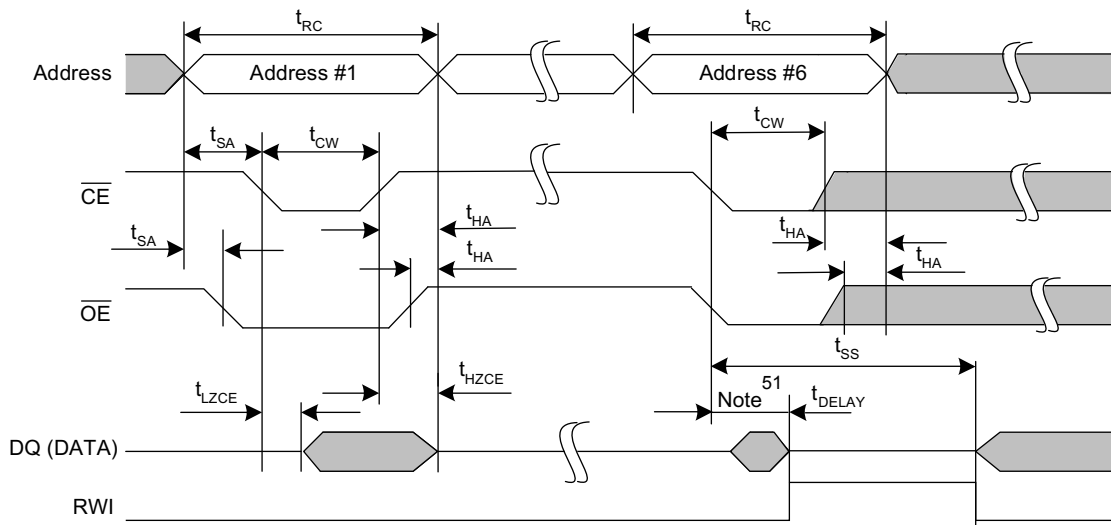

Figure 15. Autostore Enable and Disable Cycle [49]



Notes

47. The software sequence is clocked with \overline{CE} controlled or \overline{OE} controlled reads.
48. The six consecutive addresses must be read in the order listed in [Table 1](#). \overline{WE} must be HIGH during all six consecutive cycles.
49. This is the amount of time it takes to take action on a soft sequence command. V_{CC} power must remain HIGH to effectively register command.
50. Commands such as STORE and RECALL lock out I/O until operation is complete which further increases this time. See the specific command.
51. DQ output data at the sixth read may be invalid since the output is disabled at t_{DELAY} time.

Hardware STORE Cycle

Over the [Operating Range](#)

| Parameter | Description | CY14B104K/CY14B104M | | Unit |
|------------|--|---------------------|-----|------|
| | | Min | Max | |
| t_{DHSB} | HSB to output active time when write latch not set | – | 25 | ns |
| t_{PHSB} | Hardware STORE pulse width | 15 | – | ns |

Switching Waveforms – Hardware STORE Cycle

Figure 16. Hardware STORE Cycle [52]

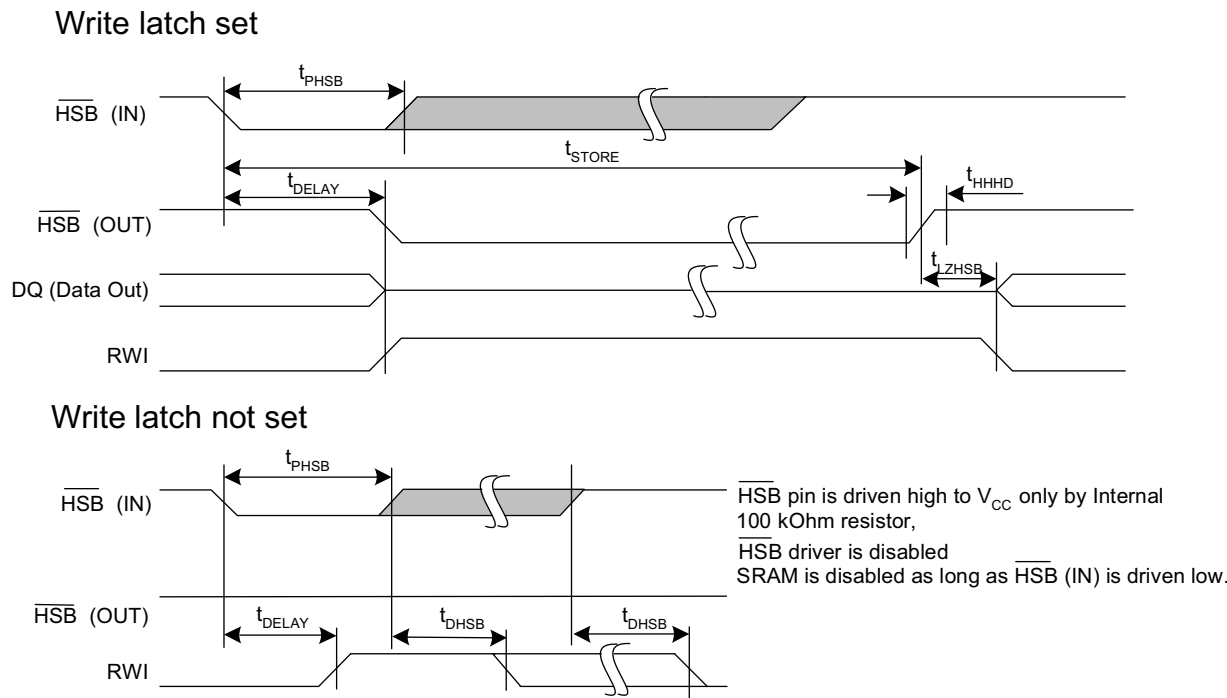
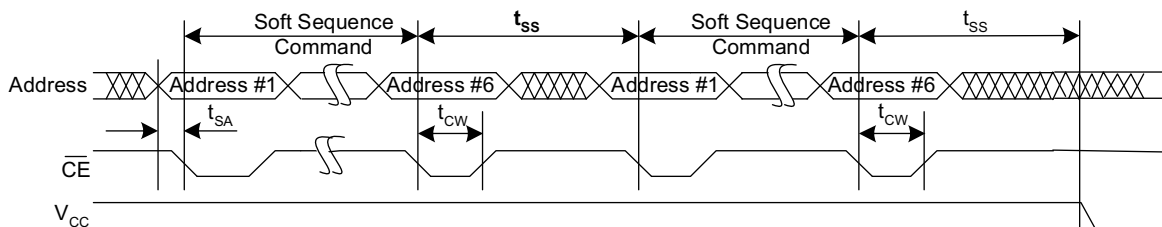

Figure 17. Soft Sequence Processing [53, 54]



Notes

52. If an SRAM write has not taken place since the last nonvolatile cycle, no AutoStore or Hardware STORE takes place.
53. This is the amount of time it takes to take action on a soft sequence command. V_{CC} power must remain HIGH to effectively register command.
54. Commands such as STORE and RECALL lock out I/O until operation is complete which further increases this time. See the specific command.

Truth Table For SRAM Operations

$\overline{\text{HSB}}$ should remain HIGH for SRAM Operations.

Table 5. Truth Table for × 8 Configuration

| $\overline{\text{CE}}$ | $\overline{\text{WE}}$ | $\overline{\text{OE}}$ | Inputs and Outputs ^[55] | Mode | Power |
|------------------------|------------------------|------------------------|--|---------------------|---------|
| H | X | X | High Z | Deselect/Power-down | Standby |
| L | H | L | Data out (DQ ₀ –DQ ₇) | Read | Active |
| L | H | H | High Z | Output disabled | Active |
| L | L | X | Data in (DQ ₀ –DQ ₇) | Write | Active |

Table 6. Truth Table for × 16 Configuration

| $\overline{\text{CE}}$ | $\overline{\text{WE}}$ | $\overline{\text{OE}}$ | $\overline{\text{BHE}}$ ^[56] | $\overline{\text{BLE}}$ ^[56] | Inputs and Outputs ^[55] | Mode | Power |
|------------------------|------------------------|------------------------|---|---|--|---------------------|---------|
| H | X | X | X | X | High Z | Deselect/Power-down | Standby |
| L | X | X | H | H | High Z | Output disabled | Active |
| L | H | L | L | L | Data out (DQ ₀ –DQ ₁₅) | Read | Active |
| L | H | L | H | L | Data out (DQ ₀ –DQ ₇); DQ ₈ –DQ ₁₅ in High Z | Read | Active |
| L | H | L | L | H | Data out (DQ ₈ –DQ ₁₅); DQ ₀ –DQ ₇ in High Z | Read | Active |
| L | H | H | L | L | High Z | Output disabled | Active |
| L | H | H | H | L | High Z | Output disabled | Active |
| L | H | H | L | H | High Z | Output disabled | Active |
| L | L | X | L | L | Data in (DQ ₀ –DQ ₁₅) | Write | Active |
| L | L | X | H | L | Data in (DQ ₀ –DQ ₇); DQ ₈ –DQ ₁₅ in High Z | Write | Active |
| L | L | X | L | H | Data in (DQ ₈ –DQ ₁₅); DQ ₀ –DQ ₇ in High Z | Write | Active |

Notes

55. Data DQ₀–DQ₇ for × 8 configuration and Data DQ₀–DQ₁₅ for × 16 configuration.

56. BHE and BLE are applicable for × 16 configuration only.

Ordering Information

| Speed (ns) | Ordering Code | Package Diagram | Package Type | Operating Range |
|------------|--------------------|-----------------|----------------|-----------------|
| 25 | CY14B104K-ZS25XIT | 51-85087 | 44-pin TSOP II | Industrial |
| | CY14B104K-ZS25XI | 51-85087 | 44-pin TSOP II | |
| | CY14B104M-ZSP25XIT | 51-85160 | 54-pin TSOP II | |
| | CY14B104M-ZSP25XI | 51-85160 | 54-pin TSOP II | |
| 45 | CY14B104K-ZS45XIT | 51-85087 | 44-pin TSOP II | |
| | CY14B104K-ZS45XI | 51-85087 | 44-pin TSOP II | |
| | CY14B104M-ZSP45XIT | 51-85160 | 54-pin TSOP II | |
| | CY14B104M-ZSP45XI | 51-85160 | 54-pin TSOP II | |

All the above parts are Pb-free.

Ordering Code Definitions

CY14 B 104 K - ZSP 25 X I T

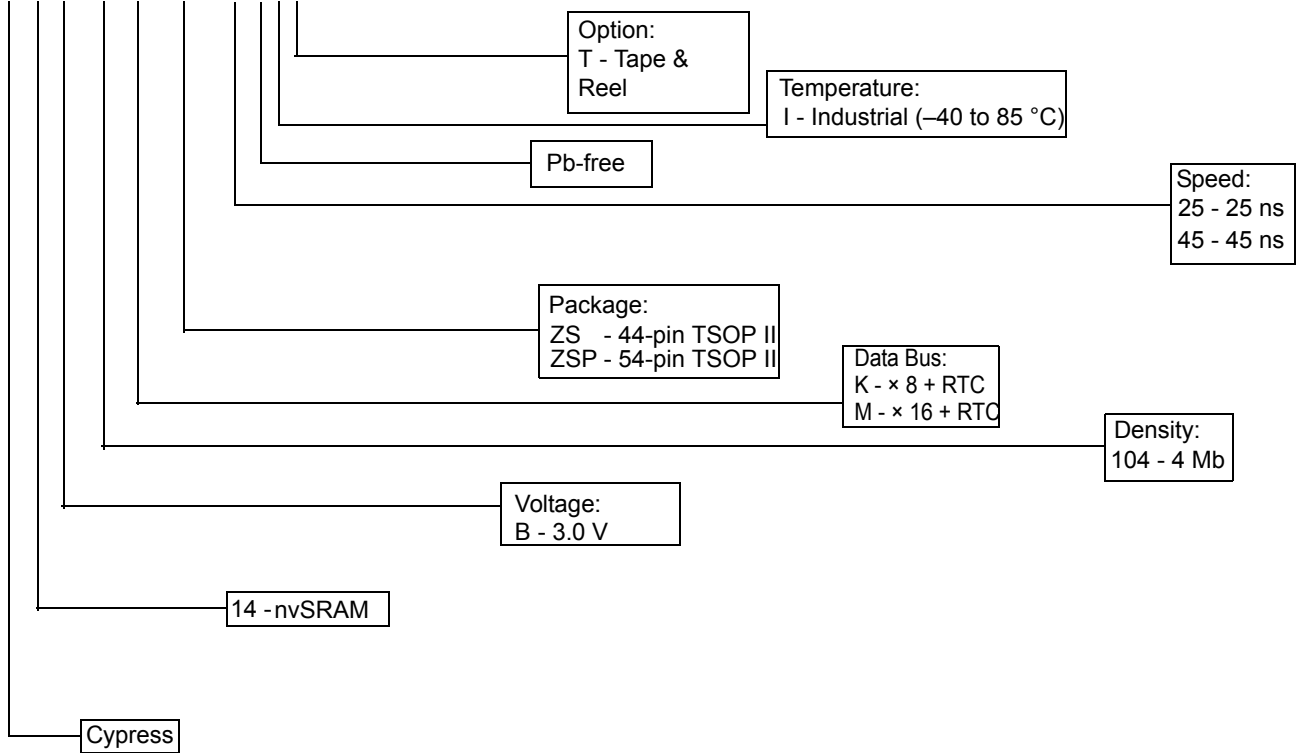

Package Diagrams

Figure 18. 44-pin TSOP II Package Outline, 51-85087

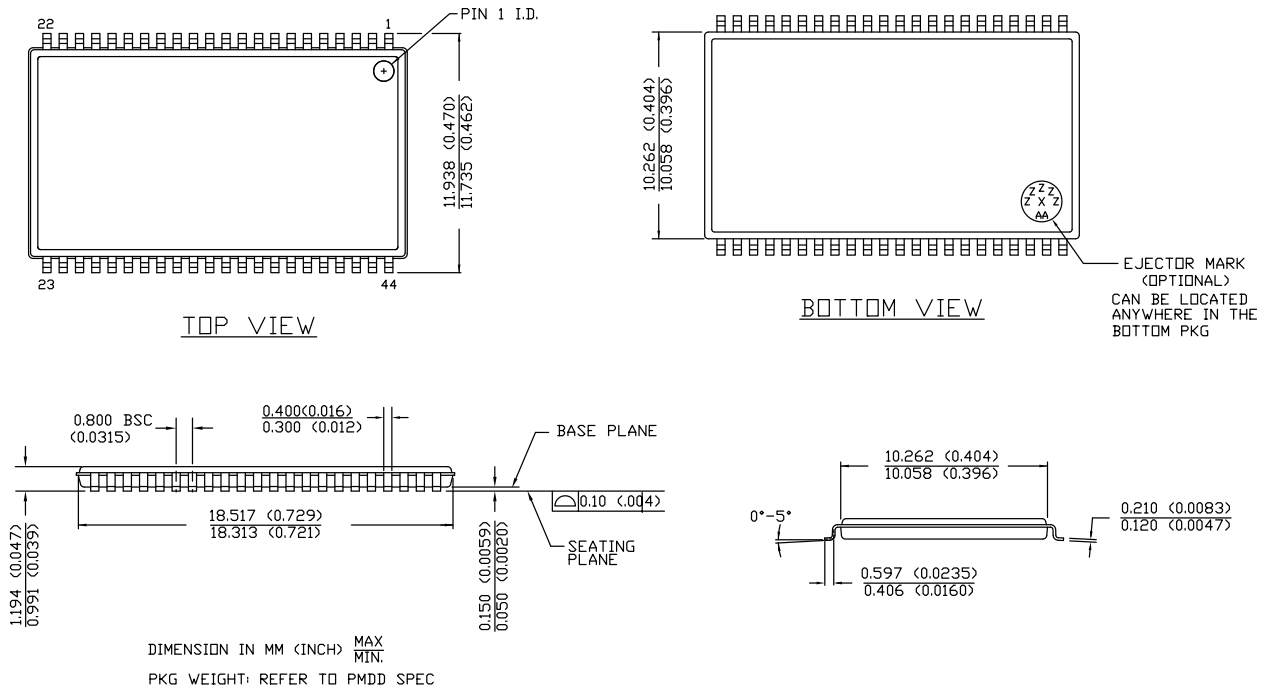

51-85087 *E

Package Diagrams (continued)

Figure 19. 54-pin TSOP II (22.4 × 11.84 × 1.0 mm) Package Outline, 51-85160

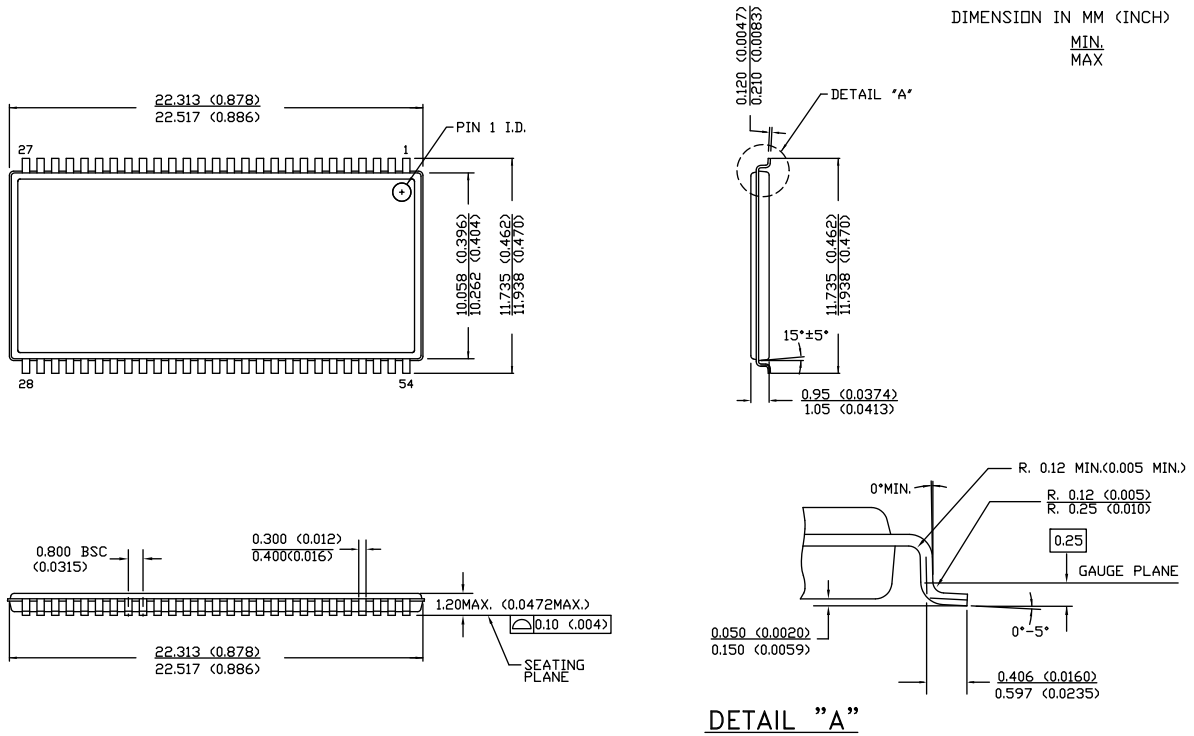

51-85160 *E

Acronyms

| Acronym | Description |
|-------------------------|---|
| BCD | binary coded decimal |
| $\overline{\text{BHE}}$ | byte high enable |
| $\overline{\text{BLE}}$ | byte low enable |
| $\overline{\text{CE}}$ | chip enable |
| CMOS | complementary metal oxide semiconductor |
| EIA | electronic industries alliance |
| $\overline{\text{HSB}}$ | hardware store busy |
| I/O | input/output |
| nvSRAM | nonvolatile static random access memory |
| OE | output enable |
| PCB | Printed circuit board |
| RoHS | restriction of hazardous substances |
| RTC | real time clock |
| RWI | read and write inhibited |
| SRAM | static random access memory |
| TSOP | thin small outline package |
| WE | write enable |

Document Conventions

Units of Measure

| Symbol | Unit of Measure |
|---------------|-------------------|
| °C | degree Celsius |
| F | farad |
| Hz | hertz |
| kHz | kilohertz |
| k Ω | kilohm |
| MHz | megahertz |
| μA | microampere |
| mA | milliampere |
| μF | microfarad |
| μs | microsecond |
| ms | millisecond |
| ns | nanosecond |
| Ω | ohm |
| % | percent |
| pF | picofarad |
| ppm | parts per million |
| sec | second |
| V | volt |
| W | watt |

Document History Page

| Document Title: CY14B104K/CY14B104M, 4-Mbit (512 K × 8/256 K × 16) nvSRAM with Real Time Clock | | | | |
|--|--------|-----------------|-----------------|---|
| Document Number: 001-07103 | | | | |
| Revision | ECN | Orig. of Change | Submission Date | Description of Change |
| ** | 431039 | TUP | See ECN | New data sheet. |
| *A | 489096 | TUP | See ECN | Removed 48 SSOP Package Added 44 TSOPII and 54 TSOPII Packages Updated Part Numbering Nomenclature and Ordering Information Added Soft Sequence Processing Time Waveform Added RTC Characteristics Table Added RTC Recommended Component Configuration |
| *B | 499597 | PCI | See ECN | Removed 35ns speed bin Added 55ns speed bin. Updated AC table for the same Changed "Unlimited" read/write to "infinite" read/write Features section: Changed typical I _{CC} at 200-ns cycle time to 8 mA Changed STORE cycles from 500K to 200K cycles. Shaded Commercial grade in operating range table. Modified I _{CC} /I _{SB} specs. Changed V _{CAP} value in DC table Added 44 TSOP II in Thermal Resistance table Modified part nomenclature table. Changes reflected in the ordering information table. |
| *C | 517793 | TUP | See ECN | Removed 55ns speed bin Changed pinout for 44TSOPII and 54TSOPII packages Changed I _{SB} to 1mA Changed I _{CC4} to 3mA Changed V _{CAP} min to 35μF Changed V _{IH} max to V _{CC} + 0.5V Changed t _{STORE} to 15ns Changed t _{PWE} to 10ns Changed t _{SCE} to 15ns Changed t _{SD} to 5ns Changed t _{AW} to 10ns Removed t _{HLBL} Added Timing Parameters for \overline{BHE} and \overline{BLE} - t _{DBE} , t _{LZBE} , t _{HZBE} , t _{BW} Removed min. specification for Vswitch Changed t _{GLAX} to 1ns Added t _{DELAY} max. of 70us Changed t _{SS} specification from 70us min. to 70us max. |
| *D | 825240 | UHA | See ECN | Changed the data sheet from Advance information to Preliminary Changed t _{DBE} to 10ns in 15ns part Changed t _{HZBE} in 15ns part to 7ns and in 25ns part to 10ns Changed t _{BW} in 15ns part to 15ns and in 25ns part to 20ns Changed t _{GLAX} to t _{GHAX} Changed the value of I _{CC3} to 25mA Changed the value of t _{AW} in 15ns part to 15ns |
| *E | 914280 | UHA | See ECN | Changed the figure-14 title from 54-Pb to 54 Pin Included all the information for 45ns part in this data sheet |

Document History Page (continued)

| Document Title: CY14B104K/CY14B104M, 4-Mbit (512 K × 8/256 K × 16) nvSRAM with Real Time Clock | | | | |
|--|---------|-----------------|-----------------|--|
| Document Number: 001-07103 | | | | |
| Revision | ECN | Orig. of Change | Submission Date | Description of Change |
| *F | 1890926 | vsutmp8 / AESA | See ECN | Added Footnote 1, 2 and 3. Updated Logic Block diagram Updated Pin definition Table Changed 8Mb Address expansion Pin from Pin 43 to Pin 42 for 44-TSOP II (x8) package. Corrected typo in V_{IL} min spec Changed the value of I_{CC3} from 25mA to 13mA Changed I_{SB} value from 1mA to 2mA Updated ordering information table Rearranging of Footnotes. Changed Package diagrams title. The pins X1 and X2 interchanged in 44TSOP II(x8) and 54TSOP II(x16) pinout diagram. |
| *G | 2267286 | GVCH / PYRS | See ECN | Rearranging of "Features" Added BHE and BLE Information in Pin Definitions Table Updated Figure 2 (Autostore mode) Updated footnote 6 RTC Register Map: Register 0x1FFF6: Changed D4 from ABE to 0 Register Map Detail: 0x1FFF6: Changed D4 from ABE to 0 and removed ABE information Changed I_{CC2} & I_{CC4} from 3mA to 6mA Changed I_{CC3} from 13mA to 15mA Changed I_{SB} from 2mA to 3mA Added input leakage current (I_{IX}) for HSB in DC Electrical Characteristics table Changed Vcap from 35uF min and 57uF max value to 54uF min and 82uF max value Corrected typo in t_{DBE} value from 22ns to 20ns for 45ns part Corrected typo in t_{HZBE} value from 22ns to 15ns for 45ns part Corrected typo in t_{AW} value from 15ns to 10ns for 15ns part Changed Vrtccap max from 2.7V to 3.6V Changed tRECALL from 100 to 200us Added footnote 10, 29 Reframed footnote 18, 25 Added footnote 18 to figure 8 (SRAM WRITE Cycle #1) Added footnote 18, 26 and 27 to figure 9 (SRAM WRITE Cycle #2) |
| *H | 2483627 | GVCH / PYRS | See ECN | Removed 8 mA typical I_{CC} at 200 ns cycle time in Feature section Referenced footnote 9 to I_{CC3} in DC Characteristics table Changed I_{CC3} from 15 mA to 35 mA Changed Vcap minimum value from 54 uF to 61 uF Changed t_{AVAV} to t_{RC} Changed V_{RTCCap} minimum value from 1.2V to 1.5V Figure 12: Changed t_{SA} to t_{AS} and t_{SCE} to t_{CW} |
| *I | 2519319 | GVCH / PYRS | 06/20/08 | Added 20 ns access speed in "Features" Added I_{CC1} for tRC=20 ns for both industrial and Commercial temperature Grade Updated Thermal resistance values for 44-TSOP II and 54-TSOP II packages Added AC Switching Characteristics specs for 20 ns access speed Added Software controlled STORE/RECALL cycle specs for 20 ns access speed Updated ordering information and Part numbering nomenclature |

Document History Page (continued)

| Document Title: CY14B104K/CY14B104M, 4-Mbit (512 K × 8/256 K × 16) nvSRAM with Real Time Clock | | | | |
|--|---------|-----------------|-----------------|--|
| Document Number: 001-07103 | | | | |
| Revision | ECN | Orig. of Change | Submission Date | Description of Change |
| *J | 2600941 | GVCH / PYRS | 11/04/08 | <p>Removed 15 ns access speed from "Features"</p> <p>Changed part number from CY14B104K/CY14B104M to CY14B104KA/CY14B104MA</p> <p>Updated Logic block diagram</p> <p>Updated footnote 1</p> <p>Added footnote 2</p> <p>Pin definition: Updated \overline{WE}, \overline{HSB} and NC pin description</p> <p>Page 4: Updated SRAM READ, SRAM WRITE, Autostore operation description</p> <p>Page 4: Updated Hardware store operation and Hardware RECALL (power-up) description</p> <p>Footnote 1 and 8 referenced for Mode selection Table</p> <p>Updated footnote 6</p> <p>Page 6: updated Data protection description</p> <p>Page 6: Updated Starting and stopping the oscillator description</p> <p>Page 7: Updated Calibrating the clock description</p> <p>Page 7: Updated Alarm description</p> <p>Page 8: Added Flags register</p> <p>Added footnote 10 and 11</p> <p>Updated Figure 4: Removed RF register and Changed C_2 value from 56pF to 12pF</p> <p>Updated Register Map Table 3</p> <p>Updated Register map detail Table 4</p> <p>Maximum Ratings: Added Max. Accumulated storage time</p> <p>Changed Output short circuit current parameter name to DC output current</p> <p>Changed I_{CC2} from 6mA to 10mA</p> <p>Changed I_{CC4} from 6mA to 5mA</p> <p>Changed I_{SB} from 3mA to 5mA</p> <p>Updated I_{CC1}, I_{CC3}, I_{SB} and I_{OZ} Test conditions</p> <p>Changed V_{CAP} voltage max value from 82uF to 180uF</p> <p>Updated footnote 12 and 13</p> <p>Added footnote 14</p> <p>Added Data retention and Endurance Table</p> <p>Updated Input Rise and Fall time in AC test Conditions</p> <p>Changed tOCS value for minimum temperature from 10 to 2 sec</p> <p>updated tOCS value for room temperature from 5 to 1sec</p> <p>Referenced footnote 20 to t_{OHA} parameter</p> <p>Updated All switching waveforms</p> <p>Updated footnote 20</p> <p>Added Figure 11 (SRAM WRITE CYCLE: \overline{BHE} and \overline{BLE} controlled)</p> <p>Updated t_{DELAY} value</p> <p>Added V_{HDIS}, t_{HHHD} and t_{LZHSB} parameters</p> <p>Updated footnote 27</p> <p>Added footnote 29</p> <p>Software controlled STORE/RECALL Table: Changed t_{AS} to t_{SA}</p> <p>Changed t_{GHAX} to t_{HA}</p> <p>Changed t_{HA} value from 1ns to 1ns</p> <p>Added t_{DHHSB} parameter</p> <p>Changed t_{HLHX} to t_{PHSB}</p> <p>Updated t_{SS} from 70us to 100us</p> <p>Added truth table for SRAM operations</p> <p>Updated ordering information and part numbering nomenclature</p> |

Document History Page (continued)

| Document Title: CY14B104K/CY14B104M, 4-Mbit (512 K × 8/256 K × 16) nvSRAM with Real Time Clock | | | | |
|--|---------|-----------------|-----------------|--|
| Document Number: 001-07103 | | | | |
| Revision | ECN | Orig. of Change | Submission Date | Description of Change |
| *K | 2653928 | GVCH / PYRS | 02/04/09 | Changed Part number from CY14B104KA/CY14B104MA to CY14B104K/CY14B104M Updated Real Time Clock operation description Added factory default values to register map table 3 Added footnote 9 Updated Flag register description in Table 4 Updated C1, C2 values to 21pF, 21pF respectively Changed I _{BAK} value from 350 nA to 450 nA at hot temperature Changed V _{RTCCap} typical value from 2.4V to 3.0V Referenced Note 15 to parameters t _{LZCE} , t _{HZCE} , t _{LZOE} , t _{HZOE} , t _{LZBE} , t _{LZWE} , t _{HZWE} and t _{HZBE} Added footnote 22 Updated Figure 13 |
| *L | 2710240 | GVCH / PYRS | 05/22/09 | Moved data sheet status from Preliminary to Final Changed pin names X ₁ , X ₂ to X _{out} , X _{in} respectively. Updated AutoStore operation Updated C1, C2 values to 12pF, 69pF from 21pF, 21pF respectively Updated I _{SB} test condition Updated footnote 11 Updated I _{BAK} and V _{RTCCap} parameter values Added R _{BKCHG} parameter to RTC characteristics table Added footnote 15 Referenced footnote 13 to V _{CCRISE} , t _{HHD} and t _{LZHSB} parameters Updated V _{HDIS} parameter description |
| *M | 2738586 | GVCH | 07/15/09 | Page 4: Updated Hardware STORE (HSB) operation description page 4: Updated Software STORE description Added best practices Updated t _{DELAY} parameter description Updated footnote 25 and added footnote 32 Referenced footnote 32 to Figure 13 and Figure 14 |
| *N | 2758397 | GVCH / AESA | 09/01/09 | Removed commercial temperature related specifications Removed 20 ns access speed related specs Changed V _{RTCbat} max value from 3.3V to 3.6V Changed R _{BKCHG} min value from 450Ω to 350Ω Updated footnote 15 |
| *O | 2826364 | GVCH / PYRS | 12/11/09 | Changed STORE cycles to QuantumTrap from 200K to 1 Million Updated I _{BAK} RTC backup current spec unit from nA to μA |
| *P | 2858300 | GVCH | 01/19/2010 | Added Contents. |
| *Q | 2923475 | GVCH / AESA | 04/27/2010 | Table 1 : Added more clarity on HSB pin operation Hardware STORE (HSB) Operation : Added more clarity on HSB pin operation Table 1 : Added more clarity on BHE/BLE pin operation Updated HSB pin operation in Figure 13 Updated footnote 27 Updated Package Diagrams |
| *R | 3132368 | GVCH | 01/10/2011 | Updated Setting the Clock description Added footnote 12 Updated W bit description in Register Map Detail table Updated Best Practices Updated input capacitance for BHE and BLE pin Updated input and output capacitance for HSB pin Added t _{RTCP} parameter to RTC Characteristics table Figure 13 : Typo error fixed Added Acronyms table and Document Conventions table |
| *S | 3150253 | GVCH | 01/21/2011 | No technical updates. |

Document History Page (continued)

| Document Title: CY14B104K/CY14B104M, 4-Mbit (512 K × 8/256 K × 16) nvSRAM with Real Time Clock | | | | |
|--|---------|-----------------|-----------------|---|
| Document Number: 001-07103 | | | | |
| Revision | ECN | Orig. of Change | Submission Date | Description of Change |
| *T | 3208661 | GVCH | 03/29/2011 | Updated thermal resistance values for all packages |
| *U | 3305495 | GVCH | 07/07/2011 | Updated DC Electrical Characteristics (Added Note 17 and referred the same note in V _{CAP} parameter). Updated AC Switching Characteristics (Added Note 23 and referred the same note in Parameters). |
| *V | 3327537 | GVCH | 07/25/2011 | Updated 54-pin TSOP II package spec. |
| *W | 3580269 | GVCH | 04/12/2012 | Updated Pin Definitions (Added Note 6 and referred the same note in V _{RTCcap} , V _{RTCbat} , Xout, Xin, INT pins). Added Note 22 and referred the same note in Figure 5 . Updated Package Diagrams . |
| *X | 3610151 | GVCH | 05/07/2012 | No technical updates. |
| *Y | 3643590 | GVCH | 06/13/2012 | Updated DC Electrical Characteristics (Added V _{V_{CAP}} parameter and its details, added Note 17 and referred the same note in V _{V_{CAP}} parameter). |
| *Z | 3724863 | GVCH | 08/27/2012 | Updated Real Time Clock Operation (description). Updated Maximum Ratings (Changed “Ambient temperature with power applied” to “Maximum junction temperature”). Updated Package Diagrams (spec 51-85160 (Changed revision from *C to *D)). |
| AA | 4048849 | GVCH | 07/03/2013 | Updated Pin Definitions : Updated HSB pin description (Added more clarity). Updated Device Operation : Updated AutoStore Operation (Removed sentence “The $\overline{\text{HSB}}$ signal is monitored by the system to detect if an AutoStore cycle is in progress.”). Updated Real Time Clock Operation : Updated Backup Power (Added Note). Added RTC External Components . Moved Figure 5 from Flags Register section to RTC External Components section. Added PCB Design Considerations for RTC . Updated Package Diagrams : spec 51-85087 – Changed revision from *D to *E. Updated to new template. |
| AB | 4568935 | GVCH | 11/14/2014 | Added documentation related hyperlink in page 1 Updated package diagram from 51-85160*D to 51-85160*E |
| AC | 4714292 | GVCH | 04/15/2015 | No technical updates. Completing Sunset Review. |
| AD | 5962042 | AESATMP8 | 11/09/2017 | Updated logo and Copyright. |

Sales, Solutions, and Legal Information

Worldwide Sales and Design Support

Cypress maintains a worldwide network of offices, solution centers, manufacturer's representatives, and distributors. To find the office closest to you, visit us at [Cypress Locations](#).

Products

| | |
|-------------------------------|--|
| ARM® Cortex® Microcontrollers | cypress.com/arm |
| Automotive | cypress.com/automotive |
| Clocks & Buffers | cypress.com/clocks |
| Interface | cypress.com/interface |
| Internet of Things | cypress.com/iot |
| Memory | cypress.com/memory |
| Microcontrollers | cypress.com/mcu |
| PSoC | cypress.com/psoc |
| Power Management ICs | cypress.com/pmic |
| Touch Sensing | cypress.com/touch |
| USB Controllers | cypress.com/usb |
| Wireless Connectivity | cypress.com/wireless |

PSoC® Solutions

[PSoC 1](#) | [PSoC 3](#) | [PSoC 4](#) | [PSoC 5LP](#) | [PSoC 6](#)

Cypress Developer Community

[Forums](#) | [WICED IOT Forums](#) | [Projects](#) | [Video](#) | [Blogs](#) | [Training](#) | [Components](#)

Technical Support

cypress.com/support

© Cypress Semiconductor Corporation, 2006-2017. This document is the property of Cypress Semiconductor Corporation and its subsidiaries, including Spansion LLC ("Cypress"). This document, including any software or firmware included or referenced in this document ("Software"), is owned by Cypress under the intellectual property laws and treaties of the United States and other countries worldwide. Cypress reserves all rights under such laws and treaties and does not, except as specifically stated in this paragraph, grant any license under its patents, copyrights, trademarks, or other intellectual property rights. If the Software is not accompanied by a license agreement and you do not otherwise have a written agreement with Cypress governing the use of the Software, then Cypress hereby grants you a personal, non-exclusive, nontransferable license (without the right to sublicense) (1) under its copyright rights in the Software (a) for Software provided in source code form, to modify and reproduce the Software solely for use with Cypress hardware products, only internally within your organization, and (b) to distribute the Software in binary code form externally to end users (either directly or indirectly through resellers and distributors), solely for use on Cypress hardware product units, and (2) under those claims of Cypress's patents that are infringed by the Software (as provided by Cypress, unmodified) to make, use, distribute, and import the Software solely for use with Cypress hardware products. Any other use, reproduction, modification, translation, or compilation of the Software is prohibited.

TO THE EXTENT PERMITTED BY APPLICABLE LAW, CYPRESS MAKES NO WARRANTY OF ANY KIND, EXPRESS OR IMPLIED, WITH REGARD TO THIS DOCUMENT OR ANY SOFTWARE OR ACCOMPANYING HARDWARE, INCLUDING, BUT NOT LIMITED TO, THE IMPLIED WARRANTIES OF MERCHANTABILITY AND FITNESS FOR A PARTICULAR PURPOSE. To the extent permitted by applicable law, Cypress reserves the right to make changes to this document without further notice. Cypress does not assume any liability arising out of the application or use of any product or circuit described in this document. Any information provided in this document, including any sample design information or programming code, is provided only for reference purposes. It is the responsibility of the user of this document to properly design, program, and test the functionality and safety of any application made of this information and any resulting product. Cypress products are not designed, intended, or authorized for use as critical components in systems designed or intended for the operation of weapons, weapons systems, nuclear installations, life-support devices or systems, other medical devices or systems (including resuscitation equipment and surgical implants), pollution control or hazardous substances management, or other uses where the failure of the device or system could cause personal injury, death, or property damage ("Unintended Uses"). A critical component is any component of a device or system whose failure to perform can be reasonably expected to cause the failure of the device or system, or to affect its safety or effectiveness. Cypress is not liable, in whole or in part, and you shall and hereby do release Cypress from any claim, damage, or other liability arising from or related to all Unintended Uses of Cypress products. You shall indemnify and hold Cypress harmless from and against all claims, costs, damages, and other liabilities, including claims for personal injury or death, arising from or related to any Unintended Uses of Cypress products.

Cypress, the Cypress logo, Spansion, the Spansion logo, and combinations thereof, WICED, PSoC, CapSense, EZ-USB, F-RAM, and Traveo are trademarks or registered trademarks of Cypress in the United States and other countries. For a more complete list of Cypress trademarks, visit cypress.com. Other names and brands may be claimed as property of their respective owners.

Компания «Life Electronics» занимается поставками электронных компонентов импортного и отечественного производства от производителей и со складов крупных дистрибьюторов Европы, Америки и Азии.

С конца 2013 года компания активно расширяет линейку поставок компонентов по направлению коаксиальный кабель, кварцевые генераторы и конденсаторы (керамические, пленочные, электролитические), за счёт заключения дистрибьюторских договоров

Мы предлагаем:

- Конкурентоспособные цены и скидки постоянным клиентам.
- Специальные условия для постоянных клиентов.
- Подбор аналогов.
- Поставку компонентов в любых объемах, удовлетворяющих вашим потребностям.
- Приемлемые сроки поставки, возможна ускоренная поставка.
- Доставку товара в любую точку России и стран СНГ.
- Комплексную поставку.
- Работу по проектам и поставку образцов.
- Формирование склада под заказчика.
- Сертификаты соответствия на поставляемую продукцию (по желанию клиента).
- Тестирование поставляемой продукции.
- Поставку компонентов, требующих военную и космическую приемку.
- Входной контроль качества.
- Наличие сертификата ISO.

В составе нашей компании организован Конструкторский отдел, призванный помогать разработчикам, и инженерам.

Конструкторский отдел помогает осуществить:

- Регистрацию проекта у производителя компонентов.
- Техническую поддержку проекта.
- Защиту от снятия компонента с производства.
- Оценку стоимости проекта по компонентам.
- Изготовление тестовой платы монтаж и пусконаладочные работы.



Тел: +7 (812) 336 43 04 (многоканальный)

Email: org@lifeelectronics.ru